

---

# **Ni-Cd/Ni-MH Batteries' Charger Protector Ics**

**R5440N2xxA SERIES**

**APPLICATION MANUAL**

### R5440N2xxA SERIES

#### OUTLINE

The R5440N2xxA Series are protection ICs for chargers of 2 serial Ni-Cd/Ni-MH batteries by CMOS process. For example, despite a charger is exclusively used for Ni-Cd or NiMH rechargeable batteries, in case that a user would try to charge Al-Mn batteries, the R5440N Series can detect over-voltage and halt a charger current. When the charger must charge over-discharge cells, charger current is controlled with pulse by way of a switching controller in the R5440N2XXA Series, therefore stress against cells can be reduced.

Each of these ICs is composed of Over-voltage detectors (VD1, VD3), Low-voltage detectors (VD2, VD4), an oscillator circuit, a reference unit, a delay circuit, and a logic circuit. When charging voltage crosses the detector threshold from a low value to a value higher than  $V_{DET1}$  or  $V_{DET3}$ , the output of OUT pin, the output of over-voltage detectors/VD1/VD3, switches to "L". During charger cycle, even if only one of VD1 and VD3 detects Over-voltage, after internally fixed delay time passes, Out pin becomes "H" and halt a charger current by turning off an external PNP transistor. After detecting over-voltage, the VD1 can be reset when the Cell-1 voltage becomes lower than " $V_{REL1}$ " and the Cell2 voltage is also lower than " $V_{REL3}$ ", after the internally fixed delay time passes, Out pin becomes to "L" level and turn on an external PNP transistor and make the charger active.

When cells are connected to the charger and even if one of cells' voltage crosses a detector threshold from a high value to a value lower than  $V_{DET2}$  or  $V_{DET4}$ , the Out pin becomes pulse charge mode. The frequency is 10kHz and ON-Duty is 10%.

During pulse charge mode, both Cell-1 and Cell reaches to Released Voltage of Low-Voltage or  $V_{REL2}$  or  $V_{REL4}$ , Out pin becomes "L" and charger returns to normal charging mode.

Output type of OUT pin is CMOS. 5-pin, SOT23-5 is available.

#### FEATURES

- Low supply current .....At Normal Charge Mode ( $V_{DD}=V_{SENS1}=2.4V$ ,  $V_{SENS2}=1.2V$ )  
Typ.  $2.0\mu A$   
At Pulse Charge Mode ( $V_{DD}=V_{SENS1}=1.2V$ ,  $V_{SENS2}=0.6V$ )  
Typ.  $5.0\mu A$
- High accuracy detector threshold.....Over-voltage detector  $\pm 50mV$   
Low-voltage detector  $\pm 50mV$
- Variety of detector threshold .....Over-voltage detector threshold  $1.5V - 1.8V$  step of  $0.05V$   
Low-voltage detector threshold  $0.8V - 1.0V$  step of  $0.05V$
- Built-in Output Delay circuit of Over-voltage Detectors  $t=20ms$
- 2 Modes exist .....Normal Charge Mode / Pulse Charge Mode)
- Small package .....SOT-23-5/5-pin

## APPLICATIONS

- Ni-Cd, Ni-MH batteries Charger protector

## BLOCK DIAGRAM

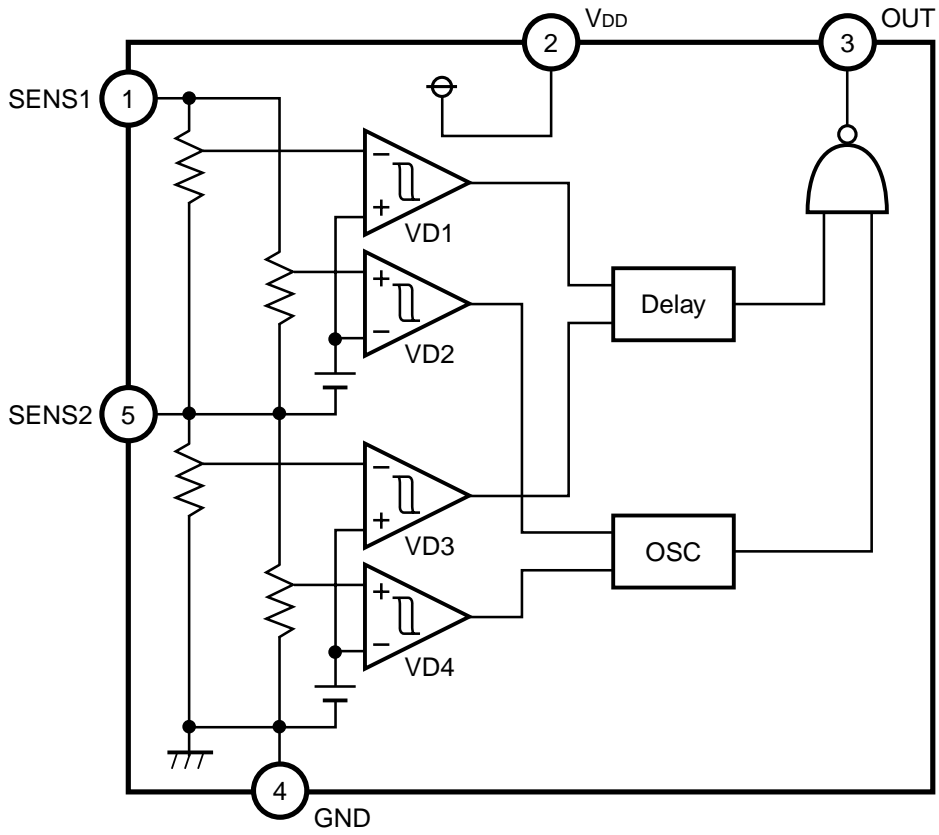

## SELECTION GUIDE

In the R5440N2xxA Series four of the input threshold for Over-voltage1, 2, Low-voltage3, and 4 detectors can be designated.

Part Number is designated as follows:

R5440N2XXA-XX ←Part Number

↑ ↑ ↑

a b c

Code	Description
a	Serial Number for the R5440N Series designating input threshold for over-voltage1, 2, Low-voltage3, 4 detectors as well as hysteresis range for those detectors.
b	Designation of version symbols
c	Taping Type: TR (refer to Taping Specification)

## PIN CONFIGURATION

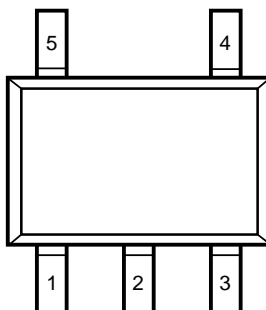

## PIN DESCRIPTION

Pin No.	Symbol	Pin description
1	SENS1	Positive Input pin of Cell-1.
2	V <sub>DD</sub>	Power supply pin. Substrate Voltage of this IC.
3	O <sub>UT</sub>	Output Pin for External switch drive, CMOS output.
4	GND	Ground Pin of this IC.
5	SENS2	Positive Input pin of Cell-2.

## ABSOLUTE MAXIMUM RATINGS

 $V_{SS}=0V$ 

Symbol	Item	Ratings	Unit
$V_{DD}$	Supply voltage	-0.3 to 12	V
$V_{SENS1}$	Input Voltage SENS1 pin of Positive input of Cell-1	-0.3 to $V_{DD} + 0.3$	V
$V_{SENS2}$	SENS2 pin of Positive input of Cell-2	-0.3 to $V_{DD} + 0.3$	V
$V_{OUT}$	Output voltage OUT pin	-0.3 to $V_{DD} + 0.3$	V
$P_D$	Power dissipation	150	mW
$T_{opt}$	Operating temperature range	-40 to 85	°C
$T_{stg}$	Storage temperature range	-55 to 125	°C

### ABSOLUTE MAXIMUM RATINGS

Absolute Maximum ratings are threshold limit values that must not be exceeded ever for an instant under any conditions. Moreover, such values for any two items must not be reached simultaneously. Operation above these absolute maximum ratings may cause degradation or permanent damage to the device. These are stress ratings only and do not necessarily imply functional operation below these limits.

## ELECTRICAL CHARACTERISTIC

## • R5440N201A

T<sub>opt</sub>=25°C

Symbol	Item	Conditions	MIN.	TYP.	MAX.	Unit
V <sub>DD</sub>	Operating input voltage		1.2		10	V
V <sub>DET1</sub>	Over-voltage threshold of Cell-1	V <sub>DD</sub> =4.0V V <sub>SENS2</sub> =1.2V	1.65	1.70	1.75	V
V <sub>REL1</sub>	Release voltage from over-voltage detection of Cell-1	V <sub>DD</sub> =4.0V V <sub>SENS2</sub> =1.2V	1.50	1.55	1.60	V
V <sub>HYS1</sub>	Over-voltage detector threshold Hysteresis range of Cell-1	V <sub>DET1</sub> -V <sub>REL1</sub>	0.05	0.15	0.25	V
t <sub>VDET</sub>	Output Delay Time for Over-voltage Detection	V <sub>DD</sub> =4.0V	10	20	40	ms
V <sub>DET3</sub>	Low-voltage detector threshold of Cell-1	V <sub>DD</sub> =4.0V V <sub>SENS2</sub> =1.2V	0.75	0.80	0.85	V
V <sub>REL3</sub>	Release voltage from Low-voltage detection of Cell-1	V <sub>DD</sub> =4.0V V <sub>SENS2</sub> =1.2V	0.80	0.85	0.90	V
V <sub>HYS3</sub>	Low-voltage detector threshold Hysteresis range	V <sub>REL3</sub> -V <sub>DET3</sub>	0.03	0.05	0.15	V
V <sub>DET2</sub>	Over-voltage threshold of Cell-2	V <sub>DD</sub> =4.0V V <sub>SENS1</sub> -V <sub>SENS2</sub> =1.2V	1.65	1.70	1.75	V
V <sub>REL2</sub>	Release voltage from over-voltage detection of Cell-2	V <sub>DD</sub> =4.0V V <sub>SENS1</sub> -V <sub>SENS2</sub> =1.2V	1.50	1.55	1.60	V
V <sub>HYS2</sub>	Over-voltage detector threshold Hysteresis range of Cell-2	V <sub>DET3</sub> -V <sub>REL3</sub>	0.05	0.15	0.25	V
t <sub>VREL</sub>	Output delay of Release-voltage from Over-voltage	V <sub>DD</sub> =4.0V	10	20	40	ms
V <sub>DET4</sub>	Low-voltage detector threshold of Cell-2	V <sub>DD</sub> =4.0V V <sub>SENS1</sub> -V <sub>SENS2</sub> =1.2V	0.75	0.80	0.85	V
V <sub>REL4</sub>	Release voltage from Low-voltage detection of Cell-2	V <sub>DD</sub> =4.0V V <sub>SENS1</sub> -V <sub>SENS2</sub> =1.2V	0.80	0.85	0.90	V
V <sub>HYS4</sub>	Low-voltage detector threshold Hysteresis range	V <sub>REL4</sub> -V <sub>DET4</sub>	0.03	0.05	0.15	V
fosc	Oscillator Frequency	V <sub>DD</sub> =4.0V, V <sub>SENS1</sub> =V <sub>SENS2</sub> =GND	5	10	15	kHz

**R5440N2xxA**

Symbol	Item	Conditions	MIN.	TYP.	MAX.	Unit
Duty	Oscillator Duty cycle	$V_{DD}=4.0V$ , $V_{SENS1}=V_{SENS2}=GND$	7	10	13	%
V <sub>ol</sub>	Nch ON voltage of OUT	$I_{ol}=3mA$ , $V_{DD}=2.4V$ , $V_{SENS1}=2.4V$ , $V_{SENS2}=1.2V$			0.15	V
V <sub>oh</sub>	Pch ON voltage of OUT	$I_{oh}=-0.3mA$ , $V_{DD}=4.0V$ , $V_{SENS1}=4.0V$ , $V_{SENS2}=2.0V$	3.5			V
I <sub>SENS1</sub>	SENS1 Input Current	$V_{SENS1}=2.4V$ , $V_{SENS2}=1.2V$		0.5	2	$\mu A$
I <sub>SENS2</sub>	SENS2 Input Current	$V_{DD}=V_{SENS1}=V_{SENS2}=1.2V$		0.5	2	$\mu A$
I <sub>DD1</sub>	Supply current1	$V_{DD}=2.4V$ , $V_{SENS1}=2.4V$ , $V_{SENS2}=1.2V$		2.0	10.0	$\mu A$
I <sub>DD2</sub>	Supply current2	$V_{DD}=1.2V$ , $V_{SENS1}=1.2V$ , $V_{SENS2}=0.6V$		5.0	30.0	$\mu A$

**• R5440N202A**

 T<sub>opt</sub>=25°C

Symbol	Item	Conditions	MIN.	TYP.	MAX.	Unit
V <sub>DD</sub>	Operating input voltage		1.2		10	V
V <sub>DET1</sub>	Over-voltage threshold of Cell-1	$V_{DD}=4.0V$ $V_{SENS2}=1.2V$	1.75	1.80	1.85	V
V <sub>REL1</sub>	Release voltage from over-voltage detection of Cell-1	$V_{DD}=4.0V$ $V_{SENS2}=1.2V$	1.50	1.55	1.60	V
V <sub>HYS1</sub>	Over-voltage detector threshold Hysteresis range of Cell-1	$V_{DET1}-V_{REL1}$	0.15	0.25	0.35	V
t <sub>VDET</sub>	Output Delay Time for Over-voltage Detection	$V_{DD}=4.0V$	10	20	40	ms
V <sub>DET3</sub>	Low-voltage detector threshold of Cell-1	$V_{DD}=4.0V$ $V_{SENS2}=1.2V$	0.75	0.80	0.85	V
V <sub>REL3</sub>	Release voltage from Low-voltage detection of Cell-1	$V_{DD}=4.0V$ $V_{SENS2}=1.2V$	0.80	0.85	0.90	V
V <sub>HYS3</sub>	Low-voltage detector threshold Hysteresis range	$V_{REL3}-V_{DET3}$	0.03	0.05	0.15	V
V <sub>DET2</sub>	Over-voltage threshold of Cell-2	$V_{DD}=4.0V$ $V_{SENS1}-V_{SENS2}=1.2V$	1.75	1.80	1.85	V
V <sub>REL2</sub>	Release voltage from over-voltage detection of Cell-2	$V_{DD}=4.0V$ $V_{SENS1}-V_{SENS2}=1.2V$	1.50	1.55	1.60	V

Symbol	Item	Conditions	MIN.	TYP.	MAX.	Unit
$V_{HYS2}$	Over-voltage detector threshold Hysteresis range of Cell-2	$V_{DET3}-V_{REL3}$	0.15	0.25	0.35	V
$t_{VREL}$	Output delay of Release-voltage from Over-voltage	$V_{DD}=4.0V$	10	20	40	ms
$V_{DET4}$	Low-voltage detector threshold of Cell-2	$V_{DD}=4.0V$ $V_{SENS1}-V_{SENS2}=1.2V$	0.75	0.80	0.85	V
$V_{REL4}$	Release voltage from Low-voltage detection of Cell-2	$V_{DD}=4.0V$ $V_{SENS1}-V_{SENS2}=1.2V$	0.80	0.85	0.90	V
$V_{HYS4}$	Low-voltage detector threshold Hysteresis range	$V_{REL4}-V_{DET4}$	0.03	0.05	0.15	V
fosc	Oscillator Frequency	$V_{DD}=4.0V$ , $V_{SENS1}=V_{SENS2}=GND$	5	10	15	kHz
Duty	Oscillator Duty cycle	$V_{DD}=4.0V$ , $V_{SENS1}=V_{SENS2}=GND$	7	10	13	%
$V_{ol}$	Nch ON voltage of OUT	$I_{ol}=3mA$ , $V_{DD}=2.4V$ , $V_{SENS1}=2.4V$ , $V_{SENS2}=1.2V$			0.15	V
$V_{oh}$	Pch ON voltage of OUT	$I_{oh}=-0.3mA$ , $V_{DD}=4.0V$ , $V_{SENS1}=4.0V$ , $V_{SENS2}=2.0V$	3.5			V
$I_{SENS1}$	SENS1 Input Current	$V_{SENS1}=2.4V$ , $V_{SENS2}=1.2V$		0.5	2	$\mu A$
$I_{SENS2}$	SENS2 Input Current	$V_{DD}=V_{SENS1}=V_{SENS2}=1.2V$		0.5	2	$\mu A$
$I_{DD1}$	Supply current1	$V_{DD}=2.4V$ , $V_{SENS1}=2.4V$ , $V_{SENS2}=1.2V$		2.0	10.0	$\mu A$
$I_{DD2}$	Supply current2	$V_{DD}=1.2V$ , $V_{SENS1}=1.2V$ , $V_{SENS2}=0.6V$		5.0	30.0	$\mu A$



## OPERATION

### • VD1, VD3/Over-Voltage Detectors

The VD1 monitors SENS1 pin voltage, while the VD3 monitors SENS2 pin voltage. When the charger including this IC is at charging cycle, and the SENS1 voltage crosses over-voltage detector threshold  $V_{DET1}$  from a low value to a value higher than the  $V_{DET1}$ , the VD1 can sense its over-voltage and internal delay time circuit is ON. Or, when the SENS2 voltage crosses over-voltage detector threshold  $V_{DET3}$  from a low value to a value higher than the  $V_{DET3}$ , the VD3 can sense its over-voltage and internal delay time circuit is ON. After the delay time of Over-voltage, and external charger controller switch or PNP-Tr. turns off with OUT pin being at “H” level and halt the charger. (Output Delay time of Over-voltage is typically set at 20ms at  $V_{DD}=4V$ . The reason why this IC have the Delay time of Over-voltage is that there may be a case of error detection before cell voltages substantially reach to each over-voltage detector threshold. Such kind of error detection is made by SENS1 or SENS2 pin voltages’ being equal or more than each Over-voltage detector threshold level because of some noise from the charger.)

After Output Delay time of Over-voltage detector, both SENS1 pin and SENS2 pin voltages are down as much as Hysteresis range from its each Over-voltage Detector threshold, VD1 and VD3 are Reset from Over-voltage detection state, and internal Delay circuit is ON. After the delay time of Release Over-voltage, Out pin becomes “L”, and PNP-Tr. turns on, therefore charger is allowable to resumption of charging process. (Output Delay time of Release from Over-voltage is typically set at 20ms at  $V_{DD}=4V$ . The reason why this IC have the Delay time of Release from Over-voltage is that there may be a case of error detection before cell voltages substantially reach to each its Release Voltage Threshold from Over-voltage. Such kind of error detection is made by SENS1 and SENS2 pin voltages’ being equal or more than each Release Voltage Threshold from Over-voltage level because of some noise from the charger.)

The OUT pin makes the “L” level from the GND pin voltage and the “H” level is set to  $V_{DD}$  voltage with CMOS buffer.

### • VD2, VD4/Low-Voltage Detectors

The VD2 monitors SENS1 pin voltage, while the VD4 monitors SENS2 pin voltage. When the charger including this IC is at a charging cycle, and the SENS1 voltage crosses the Low-voltage detector threshold  $V_{DET2}$  from a high value to a value lower than the  $V_{DET2}$ , the VD2 can sense a Low-voltage, the charger controller switch mode is pulse charging mode. (Out pin outputs a clock with 10kHz of frequency and 10% of ON-Duty cycle. Under the same condition, SENS2 voltage crosses the Low-voltage detector threshold  $V_{DET4}$  from a high value to a value lower than the  $V_{DET4}$ , the VD4 can sense a Low-voltage as well.

Both the SENS1 pin voltage and SENS2 pin voltage are equal or more than each Release voltage from Low-Voltage Detector, the charger mode becomes normal charge mode and Out pin becomes “L”.

# TEST CIRCUITS

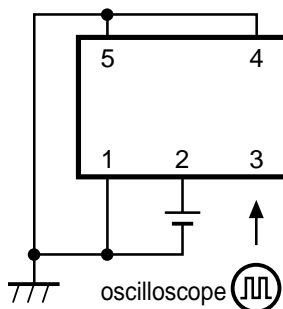

Test Circuit 1

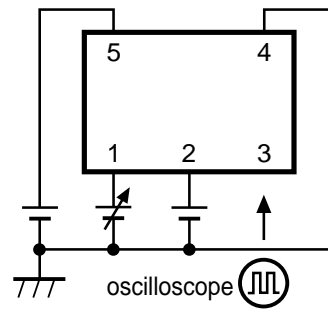

Test Circuit 2

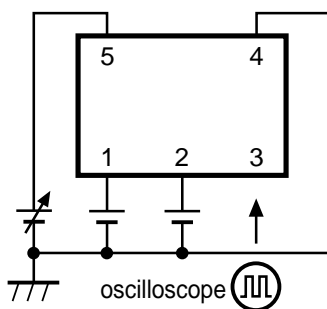

Test Circuit 3

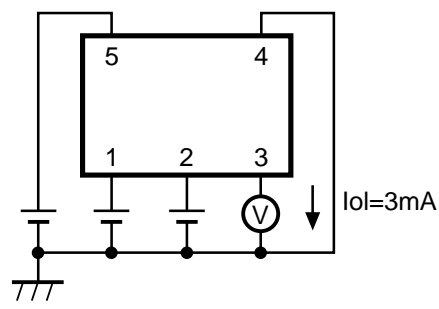

Test Circuit 4

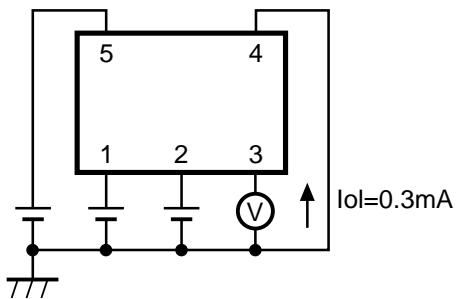

Test Circuit 5

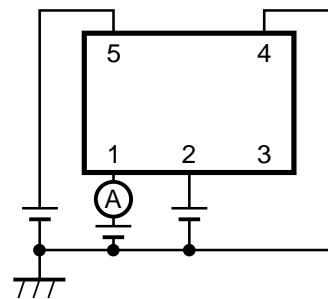

Test Circuit 6

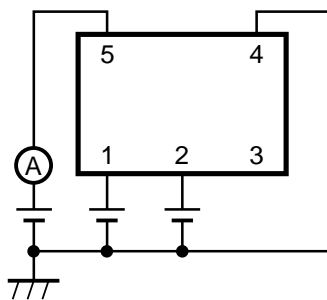

Test Circuit 7

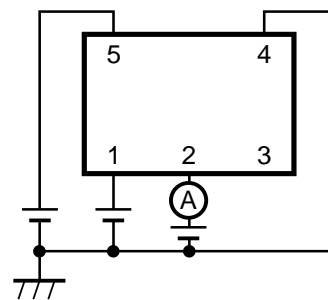

Test Circuit 8

The typical characteristics were obtained by use of these test circuits.

Test Circuit 1 : Typical Characteristics 1) 8) 9)

Test Circuit 2 : Typical Characteristics 2) 4) 6) 7)

Test Circuit 3 : Typical Characteristics 3) 5)

Test Circuit 4 : Typical Characteristics 10)

Test Circuit 5 : Typical Characteristics 11)

Test Circuit 6 : Typical Characteristics 12)

Test Circuit 7 : Typical Characteristics 13)

Test Circuit 8 : Typical Characteristics 14) 15)

## TYPICAL CHARACTERISTICS

### 1) Minimum Input Voltage vs. Temperature

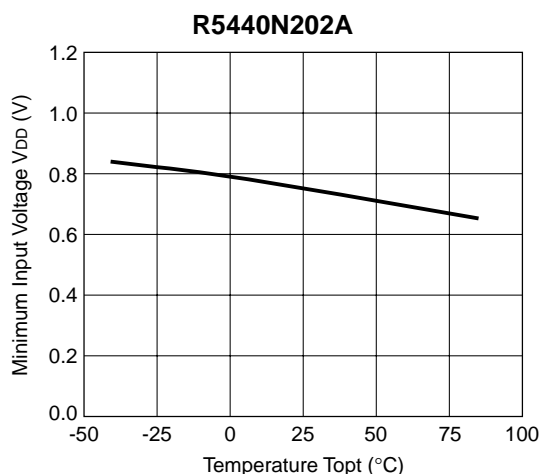

### 2) Over-Voltage Detector Threshold of Cell-1 vs. Temperature

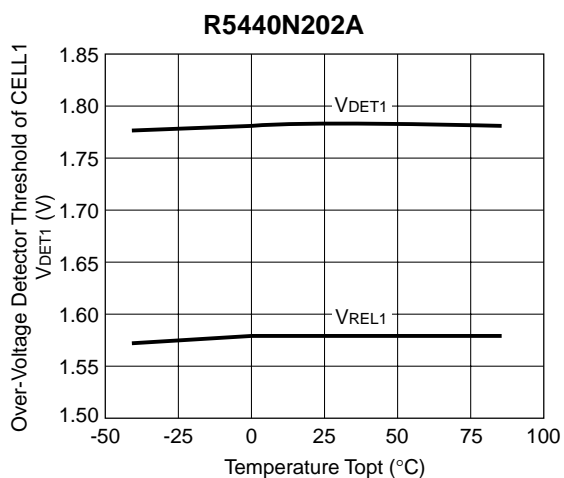

### 3) Over-Voltage Detector Threshold of Cell-2 vs. Temperature

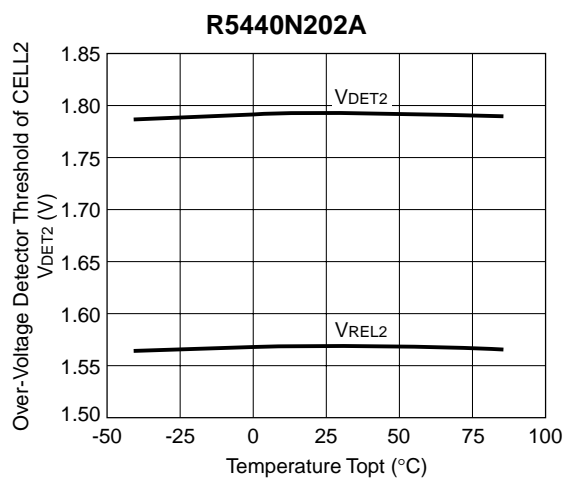

### 4) Low-Voltage Detector Threshold of Cell-1 vs. Temperature

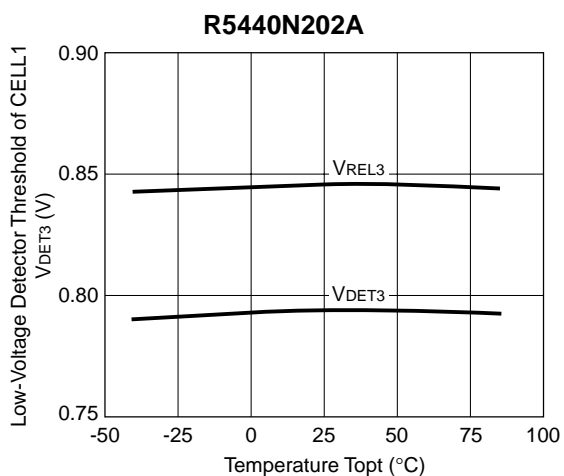

### 5) Low-Voltage Detector Threshold of Cell-2 vs. Temperature

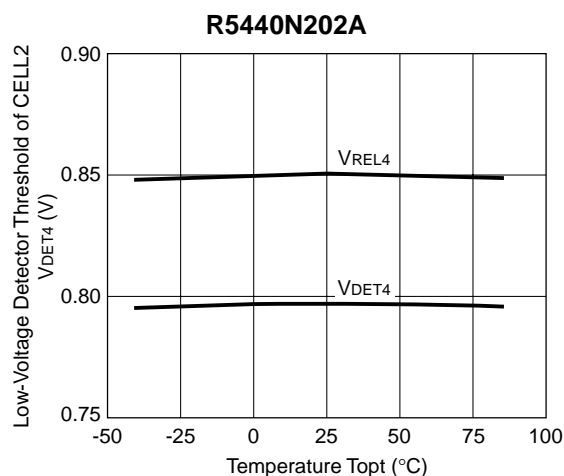

6) Output Delay of Over-voltage vs. Temperature

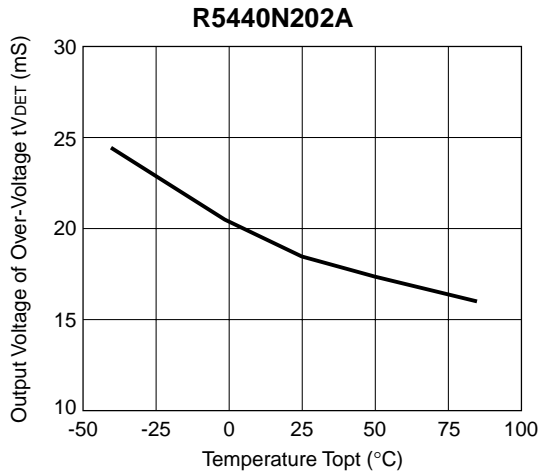

7) Output Delay of Release from Over-Voltage vs. Temperature

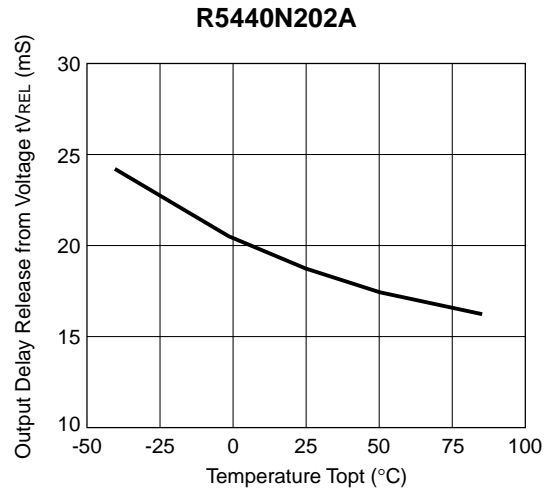

8) Oscillator Frequency vs. Temperature

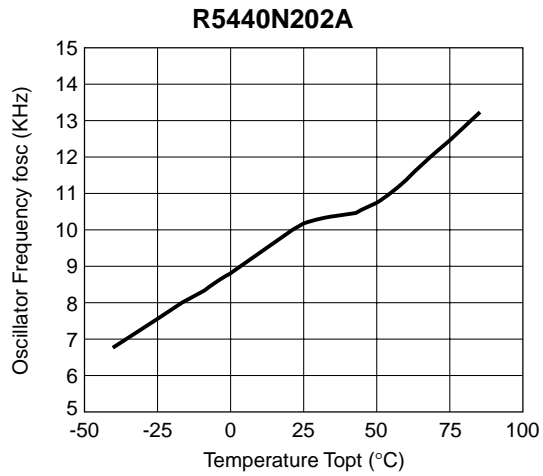

9) Oscillator Duty Cycle vs. Temperature

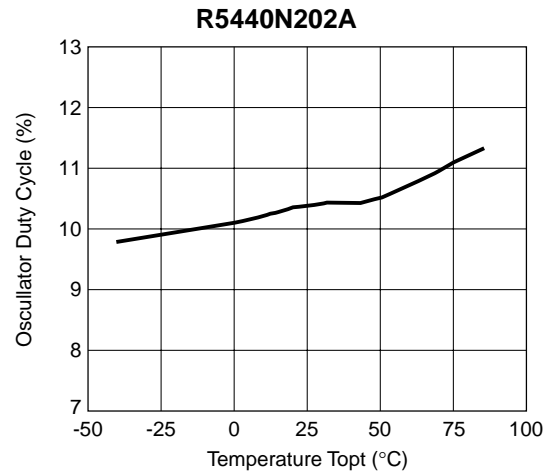

10) Nch ON Voltage vs. Temperature

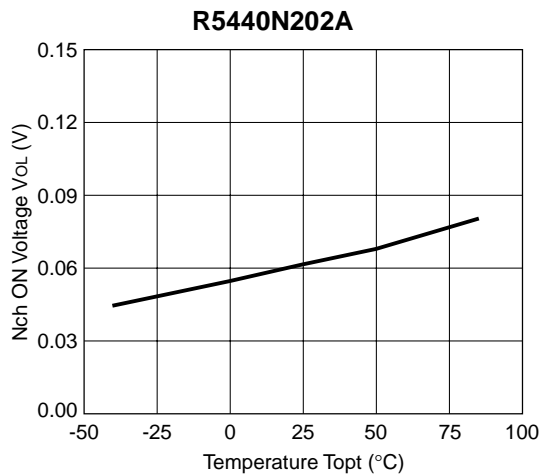

11) Pch ON Voltage vs. Temperature

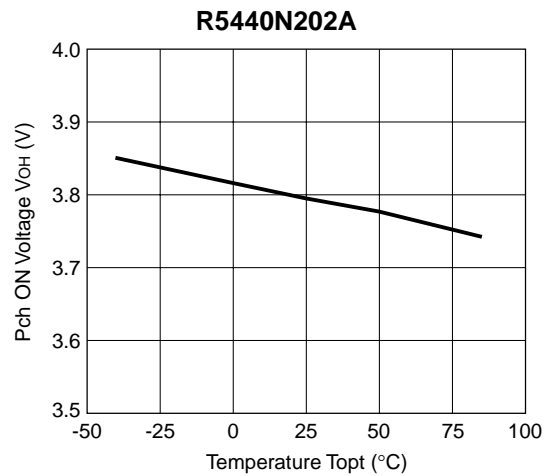

12) Input Current of SENSE1 pin vs. Temperature

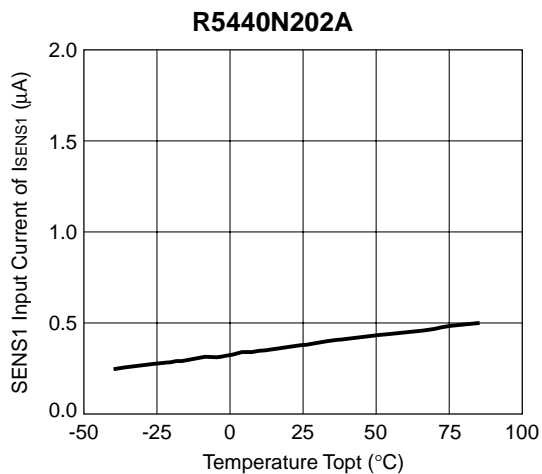

13) Input Current of SENS2 Pin vs. Temperature

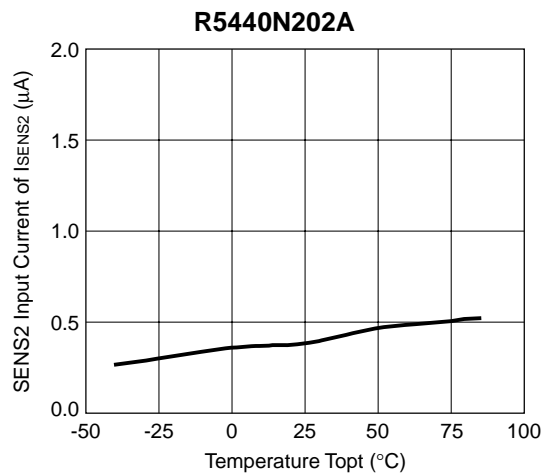

14) Supply Current 1 vs. Temperature

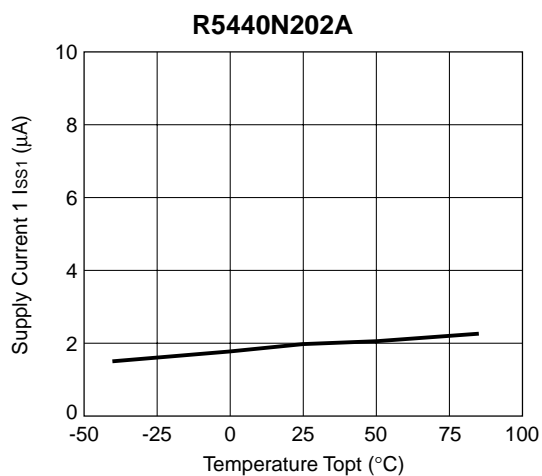

15) Supply Current 2 vs. Temperature

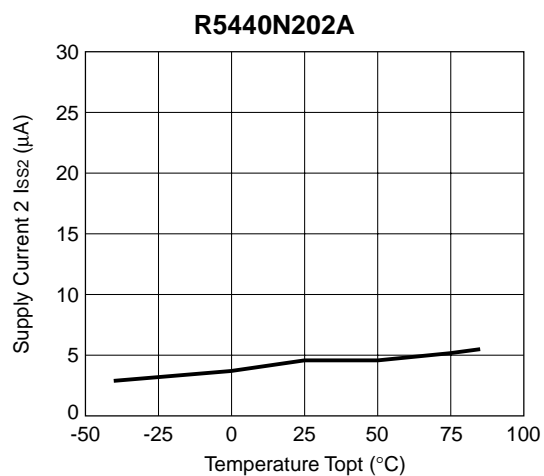

## TYPICAL APPLICATION

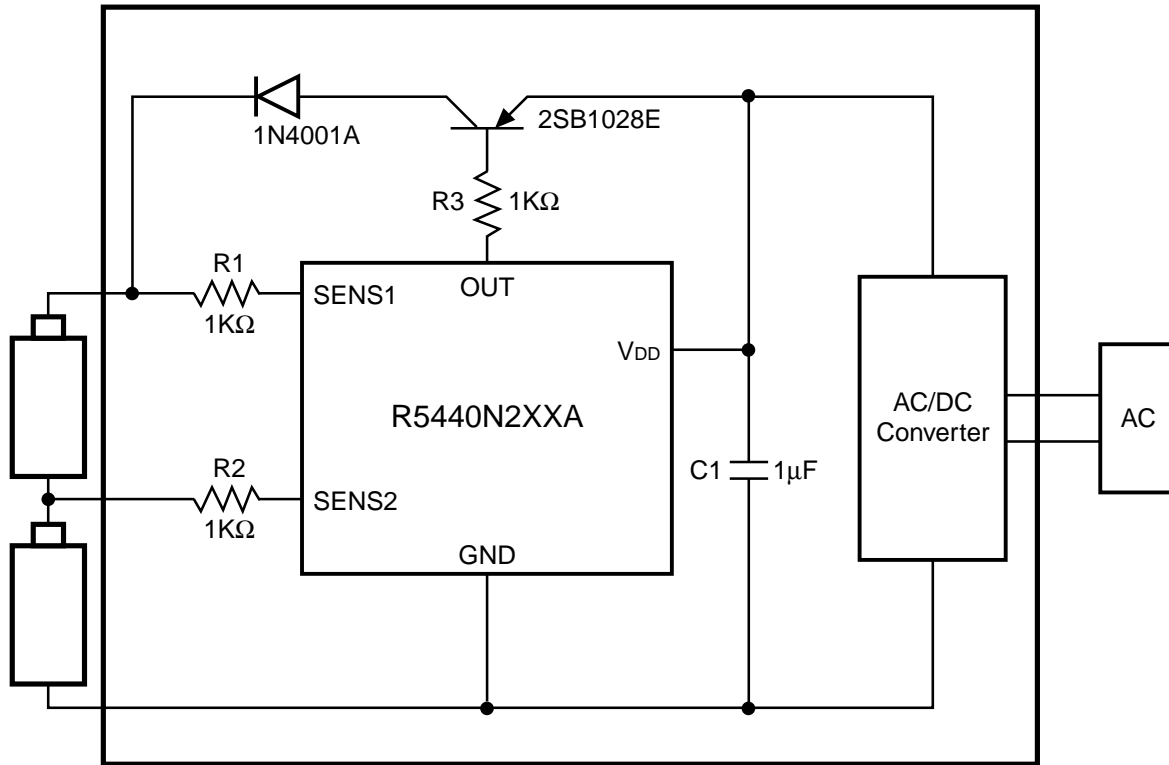

## TECHNICAL NOTES

In the typical application as shown above, when Cell-2 is connected to SENS2 pin through  $1k\Omega$  resistance and the charger is removed from the plug, Leakage Current flows from Cell-2 to  $V_{DD}$  and the circuit operates. However, under the condition as below, it does not happen.

(Condition: Cell-2=2.0V)

# TIMING DIAGRAM

