

---

# **DC/DC CONVERTER CONTROLLER**

**RV5VH SERIES**

**APPLICATION MANUAL**

### RV5VH SERIES

#### OUTLINE

Each of the RV5VH series is dual output CMOS DC/DC converter ICs integrating Step-up and inverting DC/DC converters.

The RV5VH3×× series ICs consists of an oscillator, two VFM control circuits, control transistors(EXT switches), a phase shift circuit, a voltage reference unit, an error amplifier, and voltage sensing resistors. The package for the RV5VH series is 8pin SSOP(0.65mm pitch), and it is suitable for power supply systems with positive and negative output, such as pager, PDA, which need power supplies for LCD.

RV5VH1×× and RV5VH2×× series are able to provide two DC/DC converters, one is a step-up DC/DC converter with internally fixed output and the other is an inverting DC/DC converter with adjustable output by external resistors. A voltage detector with sensing pin is also included. RV5VH3×× series are able to provide two DC/DC converters, both of them require external drivers, DC/DC1, and inverting one, DC/DC2, can be adjustable by resistors.

#### FEATURES

- Dual DC/DC converter system .....DC/DC1 : step-up  
DC/DC2 : inverting(negative voltage)
- Voltage Detector .....Nch. Open Drain Output
- Low voltage operation available  
RV5VH1××,RV5VH2×× .....oscillator start-up from 0.8V  
RV5VH3×× .....oscillator start-up from 1.8V
- High Efficiency .....TYP. 80%
- Low Supply Current
- High accuracy feedback sensing .....TYP. ±2.5%
- Sleep Mode  
RV5VH1××, RV5VH2×× .....DC/DC 2  
RV5VH3×× .....DC/DC1, 2
- Available to adjust temperature drift .....DC/DC2 : with external resistor (RV5VH2××, RV5VH3××)  
coefficient of output voltage
- Small Package .....8pin SSOP(0.65mm pitch)

#### APPLICATIONS

- Power source for telecommunication systems
- Power source for portable data processing systems, e.g. PDA, Electronic Data Banks
- Power source for Audio-Visual systems, e.g. CD players, Video cameras
- Power source for Notebook PCs, Word processing systems
- Gadgets which need two power supplies, e.g. CPU and LCD

### RV5VH1××/RV5VH2××

#### BLOCK DIAGRAM

• RV5VH1××

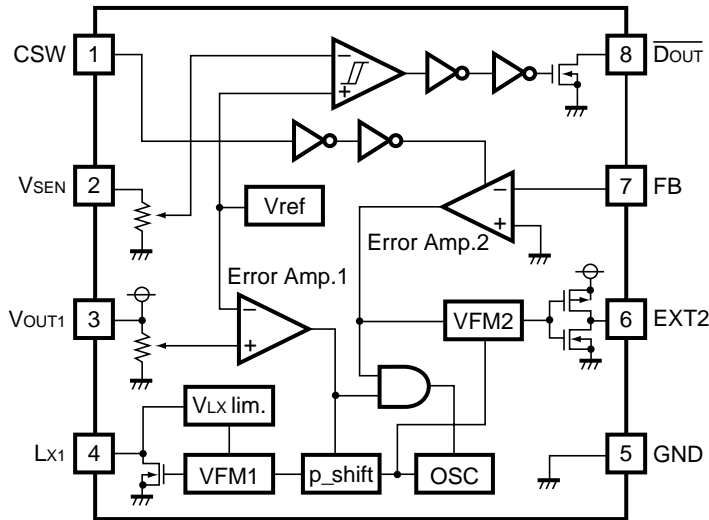

• RV5VH2××

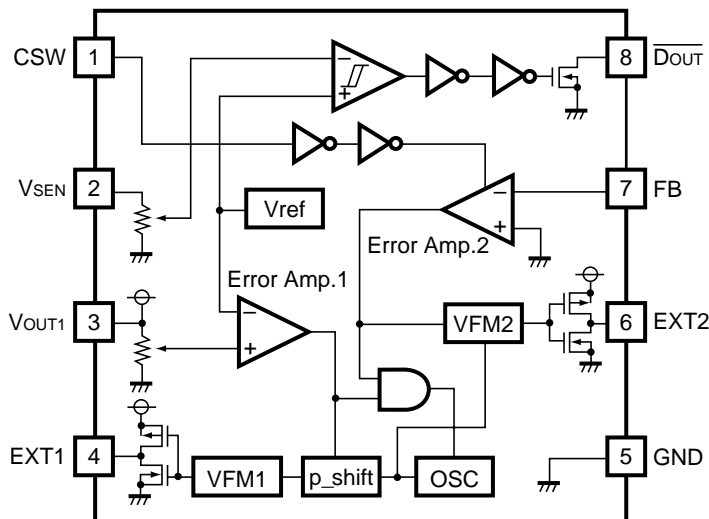

## PIN CONFIGURATION

• 8 pin SSOP (0.65mm pitch)

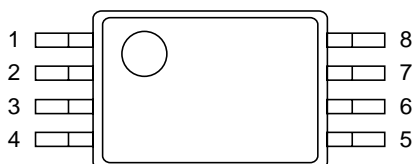

## PIN DESCRIPTION

• RV5VH1xx

Pin No.	Symbol	Description
1	CSW	Control switch for DC/DC2
2	VSEN	Sensing Pin for Voltage Detector
3	VOUT1	Output for DC/DC1, Power supply for the device
4	LX1	Output for DC/DC1, switching (Nch Open-Drain)
5	GND	Ground
6	EXT2	External Transistor drive pin for DC/DC2 (CMOS output)
7	FB	Input for DC/DC2 Error Amplifier
8	$\overline{\text{DOUT}}$	Output for Voltage detector

• RV5VH2xx

Pin No.	Symbol	Description
1	CSW	Control switch for DC/DC2
2	VSEN	Sensing Pin for Voltage Detector
3	VOUT1	Output for DC/DC1, Power supply for the device
4	EXT1	External Transistor drive pin for DC/DC1 (CMOS output)
5	GND	Ground
6	EXT2	External Transistor drive pin for DC/DC2 (CMOS output)
7	FB	Input for DC/DC2 Error Amplifier
8	$\overline{\text{DOUT}}$	Output for Voltage Detector

**ABSOLUTE MAXIMUM RATINGS**

## • RV5VH1XX

Symbol	Item	Ratings	Unit
VOUT1	VOUT1 Pin Voltage	12	V
VLX1	LX1 Pin Voltage	12	V
VSEN	VSEN Pin Voltage	12	V
DOUT	DOUT Pin Voltage	12	V
VCSW	CSW Pin Voltage	-0.3 to VOUT1 +0.3	V
VEXT2	EXT2 Pin Voltage	-0.3 to VOUT1 +0.3	V
VFB	FB Pin Voltage	-0.3 to VOUT1 +0.3	V
ILX1	LX1 Output Current	400	mA
IEXT2	EXT2 Output Current	±50	mA
PD	Power Dissipation	300	mW
Topt	Operating Temperature	-40 to +85	°C
Tstg	Storage Temperature	-55 to +125	°C
Tsolder	Lead Temperature (Soldering)	260°C 10sec	

## • RV5VH2XX

Symbol	Item	Ratings	Unit
VOUT1	VOUT1 Pin Voltage	12	V
VSEN	VSEN Pin Voltage	12	V
DOUT	$\overline{\text{DOUT}}$ Pin Voltage	12	V
VCSW	CSW Pin Voltage	-0.3 to VOUT1 +0.3	V
VEXT1,2	EXT1, 2 Pin Voltage	-0.3 to VOUT1 +0.3	V
VFB	FB Pin Voltage	-0.3 to VOUT1 +0.3	V
IEXT1,2	EXT1, 2 Output Current	±50	mA
PD	Power Dissipation	300	mW
Topt	Operating Temperature	-40 to +85	°C
Tstg	Storage Temperature	-55 to +125	°C
Tsolder	Lead Temperature (Soldering)	260°C 10sec	

## ABSOLUTE MAXIMUM RATINGS

Absolute Maximum ratings are threshold limit values that must not be exceeded even for an instant under any conditions. Moreover, such values for any two items must not be reached simultaneously. Operation above these absolute maximum ratings may cause degradation or permanent damage to the device. These are stress ratings only and do not necessarily imply functional operation below these limits.

## ELECTRICAL CHARACTERISTICS

### • RV5VH101

DC/DC Converter 1

V<sub>OUT1</sub>=3.0V, T<sub>opt</sub>=25°C

Symbol	Item	Conditions	MIN.	TYP.	MAX.	Unit
V <sub>OUT1</sub>	Step-up Output Voltage		2.925	3.000	3.075	V
V <sub>INmax</sub>	Maximum Input Voltage				10	V
V <sub>start</sub>	Oscillator Start-up Voltage	No Load		0.7	0.8	V
V <sub>hold</sub>	Hold-on Input Voltage	I <sub>OUT</sub> =1mA, V <sub>IN</sub> : 2→0V	0.7			V
I <sub>SS1</sub>	Supply Current1 *1	No Load, CSW="L"		10		μA
I <sub>LX</sub>	Lx Switching Current	V <sub>LX</sub> =0.4V	100			mA
I <sub>LXleak</sub>	Lx Leakage Current	V <sub>LX</sub> =6.0V, V <sub>IN</sub> =3.5V		0.03	1	μA
f <sub>osc</sub>	Maximum Oscillator Frequency		110	130	150	kHz
Maxdty	Oscillator Duty Cycle	ON (V <sub>LX</sub> ="L")	50	65	80	%
η	Efficiency			80		%
V <sub>LXlim</sub>	Voltage Limit for Lx Switch	for Lx pin	0.4		0.8	V
$\frac{\Delta V_{OUT1}}{\Delta T_{opt}}$	Output Voltage Temp. Coefficient	-40°C≤T <sub>opt</sub> ≤85°C		±100		ppm/°C

\* ) V<sub>IN</sub>=1.2V, I<sub>OUT</sub>=10mA, T<sub>opt</sub>=25°C, unless otherwise specified. (See Typical Application)

\*1 ) This value only shows the supply current of DC/DC1, not include the supply current of Voltage Detector and external resistors.

## DC/DC Converter 2

V<sub>OUT1</sub>=3.0V, T<sub>opt</sub>=25°C

Symbol	Item	Conditions	MIN.	TYP.	MAX.	Unit
V <sub>SET</sub>	Set Output Voltage		*1		0	V
V <sub>FB</sub>	Feed Back Voltage		-20	0	20	mV
V <sub>IN</sub>	Maximum Input Voltage				10	V
V <sub>OPTmin</sub>	Minimum Operating Voltage	I <sub>OUT</sub> =1mA			1.8	V
I <sub>SS2</sub>	Supply Current2	CSW=“H” at No Load		10		μA
I <sub>standby</sub>	Standby Current	CSW=“L”		0.3		μA
I <sub>EXT2H</sub>	EXT2 “H” Output Current	V <sub>EXT2</sub> =V <sub>OUT1</sub> -0.4V	2	4		mA
I <sub>EXT2L</sub>	EXT2 “L” Output Current	V <sub>EXT2</sub> =0.4V	4	8		mA
f <sub>osc</sub>	Maximum Oscillator Frequency		110	130	150	kHz
Maxdty	Oscillator Duty Cycle	V <sub>EXT2</sub> =“H”	40	50	60	%
V <sub>CSWH</sub>	CSW “H” Input Voltage	V <sub>OUT1</sub> =3.0V	1.6		V <sub>OUT1</sub>	V
V <sub>CSWL</sub>	CSW “L” Input Voltage	V <sub>OUT1</sub> =3.0V	0		0.4	V
I <sub>CSWleak</sub>	CSW Input Leakage Current	V <sub>OUT1</sub> =3.0V	-0.5		0.5	μA
$\frac{\Delta V_{FB}}{\Delta T_{opt}}$	Feed Back Voltage Temp. Coefficient	-40°C ≤ T <sub>opt</sub> ≤ 85°C		±30		μV/°C

\* ) V<sub>OUT1</sub>=3.0V, I<sub>OUT</sub>=1mA, T<sub>opt</sub>=25°C, unless otherwise specified. (See Typical Application)

\*1 ) Adjustable by external resistors to -30V.



## Voltage Detector

V<sub>OUT1</sub>=3.0V, T<sub>opt</sub>=25°C

Symbol	Item	Conditions	MIN.	TYP.	MAX.	Unit
V <sub>DET</sub>	Detector Threshold		2.633	2.700	2.767	V
V <sub>HYS</sub>	Detector Threshold Hysteresis		0.081	0.135	0.189	V
I <sub>SS3</sub>	Supply Current <sub>3</sub>			1.2		μA
V <sub>INmax</sub>	Maximum Input Voltage				10	V
V <sub>OPTmin</sub>	Minimum Operating Voltage				1.8	V
I <sub>OUT</sub>	Output Current	V <sub>DS</sub> =0.5V, V <sub>OUT1</sub> =1.5V	1.0	2.0		mA
		V <sub>DS</sub> =0.5V, V <sub>OUT1</sub> =3.0V	4.0	5.0		mA
I <sub>SEN</sub>	Sensing pin Input Current	V <sub>SEN</sub> =3.0V		0.3	1.2	μA
V <sub>SEN</sub>	Sensing pin Input Voltage		0.7		10	V
t <sub>PLH</sub>	Output Delay				100	μs
$\frac{\Delta V_{OUT1}}{\Delta T_{opt}}$	Detector Threshold Temp.Coefficient	-40°C ≤ T <sub>opt</sub> ≤ 85°C		±100		ppm/°C
I <sub>DOUTleak</sub>	$\overline{DOUT}$ Leakage Current			0.03	0.5	μA

\* ) V<sub>OUT1</sub>=3.0V, T<sub>opt</sub>=25°C, unless otherwise specified. (See Typical Application)

## • RV5VH102

## DC/DC Converter 1

V<sub>OUT1</sub>=5.0V, T<sub>opt</sub>=25°C

Symbol	Item	Conditions	MIN.	TYP.	MAX.	Unit
V <sub>OUT1</sub>	Step-up Output Voltage		4.875	5.000	5.125	V
V <sub>INmax</sub>	Maximum Input Voltage				10	V
V <sub>start</sub>	Oscillator Start-up Voltage	No Load		0.7	0.8	V
V <sub>hold</sub>	Hold-on Input Voltage	I <sub>OUT</sub> =1mA, V <sub>IN</sub> : 2→0V	1.2			V
I <sub>SS1</sub>	Supply Current1 *1	No Load, CSW="L"		15		μA
I <sub>LX</sub>	Lx Switching Current	V <sub>LX</sub> =0.4V	100			mA
I <sub>LXleak</sub>	Lx Leakage Current	V <sub>LX</sub> =6.0V, V <sub>IN</sub> =5.5V		0.03	1	μA
f <sub>osc</sub>	Maximum Oscillator Frequency		110	130	150	kHz
Maxdty	Oscillator Duty Cycle	ON (V <sub>LX</sub> ="L")	55	70	85	%
η	Efficiency			80		%
V <sub>LXlim</sub>	Voltage Limit for Lx Switch		0.4		0.8	V
$\frac{\Delta V_{OUT1}}{\Delta T_{opt}}$	Output Voltage Temp. Coefficient	-40°C≤T <sub>opt</sub> ≤85°C		±100		ppm/°C

\* ) V<sub>IN</sub>=1.2V, I<sub>OUT</sub>=10mA, T<sub>opt</sub>=25°C, unless otherwise specified. (See Typical Application)

\*1 ) This value only shows the supply current of DC/DC1, not include the supply current of Voltage Detector and external resistors.

## DC/DC Converter 2

V<sub>OUT1</sub>=5.0V, T<sub>opt</sub>=25°C

Symbol	Item	Conditions	MIN.	TYP.	MAX.	Unit
V <sub>SET</sub>	Set Output Voltage		*1	-3.000	0	V
V <sub>FB</sub>	Feed Back Voltage			0		mV
V <sub>IN</sub>	Maximum Input Voltage				10	V
V <sub>OPTmin</sub>	Minimum Operating Voltage	I <sub>OUT</sub> =1mA			1.8	V
I <sub>SS2</sub>	Supply Current2	CSW= "H" at No Load		25		μA
I <sub>standby</sub>	Standby Current	CSW="L"		0.3		μA
I <sub>EXT2H</sub>	EXT2 "H" Output Current	V <sub>EXT2</sub> =V <sub>OUT1</sub> -0.4V	3	6		mA
I <sub>EXT2L</sub>	EXT2 "L" Output Current	V <sub>EXT2</sub> =0.4V	7	14		mA
f <sub>osc</sub>	Maximum Oscillator Frequency		110	130	150	kHz
Maxdty	Oscillator Duty Cycle	V <sub>EXT2</sub> ="H"	40	50	60	%
V <sub>CSWH</sub>	CSW "H" Input Voltage	V <sub>OUT1</sub> =5.0V	1.6		V <sub>OUT1</sub>	V
V <sub>CSWL</sub>	CSW "L" Input Voltage	V <sub>OUT1</sub> =5.0V	0		0.4	V
I <sub>CSWleak</sub>	CSW Input Leakage Current	V <sub>OUT1</sub> =5.0V	-0.5		0.5	μA
$\frac{\Delta V_{FB}}{\Delta T_{opt}}$	Feed Back Voltage Temp. Coefficient	-40°C ≤ T <sub>opt</sub> ≤ 85°C		±30		μV/°C

\* ) V<sub>OUT1</sub>=3.0V, I<sub>OUT</sub>=1mA, T<sub>opt</sub>=25°C, unless otherwise specified. (See Typical Application)

\*1 ) Adjustable by external resistors to -30V.

## Voltage Detector

V<sub>OUT1</sub>=5.0V, T<sub>opt</sub>=25°C

Symbol	Item	Conditions	MIN.	TYP.	MAX.	Unit
V <sub>DET</sub>	Detector Threshold		4.388	4.500	4.612	V
V <sub>HYS</sub>	Detector Threshold Hysteresis		0.135	0.225	0.315	V
I <sub>SS3</sub>	Supply Current <sup>3*1</sup>			1.8		μA
V <sub>INmax</sub>	Maximum Input Voltage				10	V
V <sub>OPTmin</sub>	Minimum Operating Voltage <sup>*2</sup>				1.8	V
I <sub>OUT</sub>	Output Current	V <sub>DS</sub> =0.5V, V <sub>OUT1</sub> =1.5V	1.0	2.0		mA
		V <sub>DS</sub> =0.5V, V <sub>OUT1</sub> =5.0V	7.0	10.0		mA
I <sub>SEN</sub>	Sensing Pin Input Current	V <sub>SEN</sub> =5.0V		0.7	2.0	μA
t <sub>PLH</sub>	Output Delay				100	μs
$\frac{\Delta V_{OUT1}}{\Delta T_{opt}}$	Detector Threshold Temp.Coefficient	-40°C ≤ T <sub>opt</sub> ≤ 85°C		±100		ppm/°C
I <sub>DOUTleak</sub>	$\overline{DOUT}$ Leakage Current			0.03	0.5	μA

■ \* ) V<sub>OUT1</sub>=3.0V, T<sub>opt</sub>=25°C, unless otherwise specified. (See Typical Application)

## • RV5VH201

## DC/DC Converter 1

V<sub>OUT1</sub>=3.0V, T<sub>opt</sub>=25°C

Symbol	Item	Conditions	MIN.	TYP.	MAX.	Unit
V <sub>OUT1</sub>	Step-up Output Voltage	I <sub>OUT</sub> =0mA	2.925	3.000	3.075	V
V <sub>INmax</sub>	Maximum Input Voltage				10	V
V <sub>start</sub>	Oscillator Start-up Voltage	No Load		0.7	0.8	V
V <sub>hold</sub>	Hold-on Input Voltage	I <sub>OUT</sub> =1mA	0.7			V
I <sub>SS1</sub>	Supply Current1 *1	I <sub>OUT</sub> =0mA, CSW="L"		80		μA
I <sub>EXT1H</sub>	EXT1 "H" Output Current	V <sub>EXT2</sub> =V <sub>OUT1</sub> -0.4V	1.5	3		mA
I <sub>EXT1L</sub>	EXT1 "L" Output Current	V <sub>EXT2</sub> =0.4V	4	8		mA
f <sub>osc</sub>	Maximum Oscillator Frequency		110	130	150	kHz
Maxdty	Oscillator Duty Cycle	ON (V <sub>LX</sub> ="L")	50	65	80	%
$\frac{\Delta V_{OUT1}}{\Delta T_{opt}}$	Output Voltage Temp. Coefficient	-40°C ≤ T <sub>opt</sub> ≤ 85°C		±100		ppm/°C

\* ) V<sub>IN</sub>=1.2V, I<sub>OUT</sub>=10mA, unless otherwise specified. (See Typical Application)

\*1 ) This value shows only the supply current of DC/DC1, not include the supply current of Voltage Detector and external resistors.

## DC/DC Converter 2

V<sub>OUT1</sub>=3.0V, T<sub>opt</sub>=25°C

Symbol	Item	Conditions	MIN.	TYP.	MAX.	Unit
VSET	Output Voltage Setting Range		*1		0	V
VFB	Feed Back Voltage		-20	0	20	mV
V <sub>IN</sub>	Maximum Input Voltage				10	V
V <sub>OPTmin</sub>	Minimum Operating Voltage*2	I <sub>OUT</sub> =1mA			1.8	V
I <sub>SS2</sub>	Supply Current2*3	CSW= "H" I <sub>OUT</sub> =0mA		10		μA
I <sub>standby</sub>	Standby Current	CSW="L"		0.3		μA
I <sub>EXT2H</sub>	EXT2 "H" Output Current	V <sub>EXT2</sub> =V <sub>OUT1</sub> -0.4V	2	4		mA
I <sub>EXT2L</sub>	EXT2 "L" Output Current	V <sub>EXT2</sub> =0.4V	4	8		mA
f <sub>osc</sub>	Maximum Oscillator Frequency		110	130	150	kHz
Maxdty	Oscillator Duty Cycle	V <sub>EXT2</sub> ="H"	40	50	60	%
V <sub>CSWH</sub>	CSW "H" Input Voltage	V <sub>OUT1</sub> =3.0V	1.6		V <sub>OUT1</sub>	V
V <sub>CSWL</sub>	CSW "L" Input Voltage	V <sub>OUT1</sub> =3.0V	0		0.4	V
I <sub>CSWleak</sub>	CSW Input Leakage Current	CSW=3.0V	-0.5		0.5	μA
$\frac{\Delta V_{FB}}{\Delta T_{opt}}$	Feed Back Voltage Temp. Coefficient	-40°C ≤ T <sub>opt</sub> ≤ 85°C		±30		μV/°C

\* ) V<sub>OUT1</sub>=3.0V, V<sub>OUT2</sub>=-0.3V, I<sub>OUT2</sub>=1mA, unless otherwise specified. (See Typical Application)

\*1 ) Adjustable by external resistors to -30V.

\*2 ) "Minimum Operating Voltage" means a voltage for the "V<sub>OUT1</sub>" pin.

\*3 ) This value shows only the supply current of DC/DC2, not include the supply current of external resistors.

## Voltage Detector

V<sub>OUT1</sub>=3.0V, T<sub>opt</sub>=25°C

Symbol	Item	Conditions	MIN.	TYP.	MAX.	Unit
V <sub>DET</sub>	Detector Threshold		2.633	2.700	2.767	V
V <sub>HYS</sub>	Detector Threshold Hysteresis		0.081	0.135	0.189	V
I <sub>SS3</sub>	Supply Current <sup>3</sup> *1			1.2		μA
V <sub>INmax</sub>	Maximum Input Voltage				10	V
V <sub>OPTmin</sub>	Minimum Operating Voltage*2				1.8	V
I <sub>OUT</sub>	Output Current	V <sub>DS</sub> =0.5V, V <sub>OUT1</sub> =1.5V	1.0	2.0		mA
		V <sub>DS</sub> =0.5V, V <sub>OUT1</sub> =3.0V	4.0	5.0		mA
I <sub>SEN</sub>	Sensing Pin Input Current	V <sub>SEN</sub> =3.0V		0.3	1.2	μA
t <sub>PLH</sub>	Output Delay				100	μs
$\frac{\Delta V_{OUT1}}{\Delta T_{opt}}$	Detector Threshold Temp. Coefficient	-40°C ≤ T <sub>opt</sub> ≤ 85°C		±100		ppm/°C
I <sub>DOUTleak</sub>	D <sub>OUT</sub> Leakage Current			0.03	0.5	μA

\* ) V<sub>OUT1</sub>=3.0V : unless otherwise specified. (See Typical Application)

\*1 ) This value only shows the supply current of voltage detector.

\*2 ) "Minimum Operating Voltage" means a voltage for the "V<sub>OUT1</sub>" pin.

## • RV5VH202

DC/DC Converter 1

V<sub>OUT1</sub>=5.0V, T<sub>opt</sub>=25°C

Symbol	Item	Conditions	MIN.	TYP.	MAX.	Unit
V <sub>OUT1</sub>	Step-up Output Voltage	I <sub>OUT</sub> =0mA	4.875	5.000	5.125	V
V <sub>INmax</sub>	Maximum Input Voltage				10	V
V <sub>start</sub>	Oscillator Start-up Voltage	No Load		0.7	0.8	V
V <sub>hold</sub>	Hold-on Input Voltage	I <sub>OUT</sub> =1mA	0.7			V
I <sub>SS1</sub>	Supply Current1 *1	I <sub>OUT</sub> =0mA, CSW="L"		40		μA
I <sub>EXT1H</sub>	EXT1 "H" Output Current	V <sub>EXT2</sub> =V <sub>OUT1</sub> -0.4V	2	4		mA
I <sub>EXT1L</sub>	EXT1 "L" Output Current	V <sub>EXT2</sub> =0.4V	7	14		mA
f <sub>osc</sub>	Maximum Oscillator Frequency		110	130	150	kHz
Maxdty	Oscillator Duty Cycle	ON (V <sub>LX</sub> ="L")	55	70	85	%
η	Efficiency			80		%
$\frac{\Delta V_{OUT1}}{\Delta T_{opt}}$	Output Voltage Temp. Coefficient	-40°C ≤ T <sub>opt</sub> ≤ 85°C		±100		ppm/°C

\* ) V<sub>IN</sub>=3.0V, I<sub>OUT</sub>=10mA : unless otherwise specified. (See Typical Application)

\*1 ) This value only shows the supply current of DC/DC1, does not include the supply current of Voltage Detector and external resistors.



## DC/DC Converter 2

V<sub>OUT1</sub>=5.0V, T<sub>opt</sub>=25°C

Symbol	Item	Conditions	MIN.	TYP.	MAX.	Unit
V <sub>SET</sub>	Output Voltage Setting Range		*1		0	V
V <sub>FB</sub>	Feed Back Voltage			0		mV
V <sub>IN</sub>	Maximum Input Voltage				10	V
V <sub>OPTmin</sub>	Minimum Operating Voltage*2	I <sub>OUT</sub> =1mA			1.8	V
I <sub>SS2</sub>	Supply Current2*3	CSW= "H", No Load		25		μA
I <sub>standby</sub>	Standby Current	CSW="L"		0.3		μA
I <sub>EXT2H</sub>	EXT2 "H" Output Current	V <sub>EXT2</sub> =V <sub>OUT1</sub> -0.4V	3	6		mA
I <sub>EXT2L</sub>	EXT2 "L" Output Current	V <sub>EXT2</sub> =0.4V	7	14		mA
f <sub>osc</sub>	Maximum Oscillator Frequency		110	130	150	kHz
Maxdty	Oscillator Duty Cycle	V <sub>EXT2</sub> ="H"	40	50	60	%
V <sub>CSWH</sub>	CSW "H" Input Voltage	V <sub>OUT1</sub> =5.0V	1.6		V <sub>OUT1</sub>	V
V <sub>CSWL</sub>	CSW "L" Input Voltage	V <sub>OUT1</sub> =5.0V	0		0.4	V
I <sub>CSWleak</sub>	CSW Input Leakage Current	CSW=5.0V	-0.5		0.5	μA
$\frac{\Delta V_{FB}}{\Delta T_{opt}}$	Feed Back Voltage Temp.Coefficient	-40°C≤T <sub>opt</sub> ≤85°C		±30		μV/°C

\* ) V<sub>OUT1</sub>=5.0V, V<sub>OUT2</sub>=-3.0V, I<sub>OUT2</sub>=1mA : unless otherwise specified. (See Typical Application)

\*1 ) Adjustable by external resistors to -30V.

\*2 ) "Minimum Operating Voltage" means a voltage for the "V<sub>OUT1</sub>" pin.

\*3 ) This value shows only the supply current of DC/DC2, not include the supply current of external resistors.

## Voltage Detector

V<sub>OUT1</sub>=5.0V, T<sub>opt</sub>=25°C

Symbol	Item	Conditions	MIN.	TYP.	MAX.	Unit
V <sub>DET</sub>	Detector Threshold		4.388	4.500	4.612	V
V <sub>HYS</sub>	Detector Threshold Hysteresis		0.135	0.225	0.315	V
I <sub>SS3</sub>	Supply Current <sup>3*1</sup>			1.8		μA
V <sub>INmax</sub>	Maximum Input Voltage				10	V
V <sub>OPTmin</sub>	Minimum Operating Voltage <sup>*2</sup>				1.8	V
I <sub>OUT</sub>	Output Current	V <sub>DS</sub> =0.5V, V <sub>OUT1</sub> =1.5V	1.0	2.0		mA
		V <sub>DS</sub> =0.5V, V <sub>OUT1</sub> =5.0V	7.0	10.0		mA
I <sub>SEN</sub>	Sensing Pin Input Current	V <sub>SEN</sub> =5.0V		0.7	2.0	μA
t <sub>PLH</sub>	Output Delay				100	μs
$\frac{\Delta V_{OUT1}}{\Delta T_{opt}}$	Detector Threshold Temp.Coefficient	-40°C ≤ T <sub>opt</sub> ≤ 85°C		±100		ppm/°C
I <sub>DOUTleak</sub>	$\overline{DOUT}$ Leakage Current			0.03	0.5	μA

\* ) V<sub>OUT1</sub>=5.0V : unless otherwise specified. (See Typical Application)

\*1 ) This value only shows the supply current of voltage detector.

\*2 ) "Minimum Operating Voltage" means a voltage for the "V<sub>OUT1</sub>" pin.

## OPERATION

### • DC/DC Converter 1

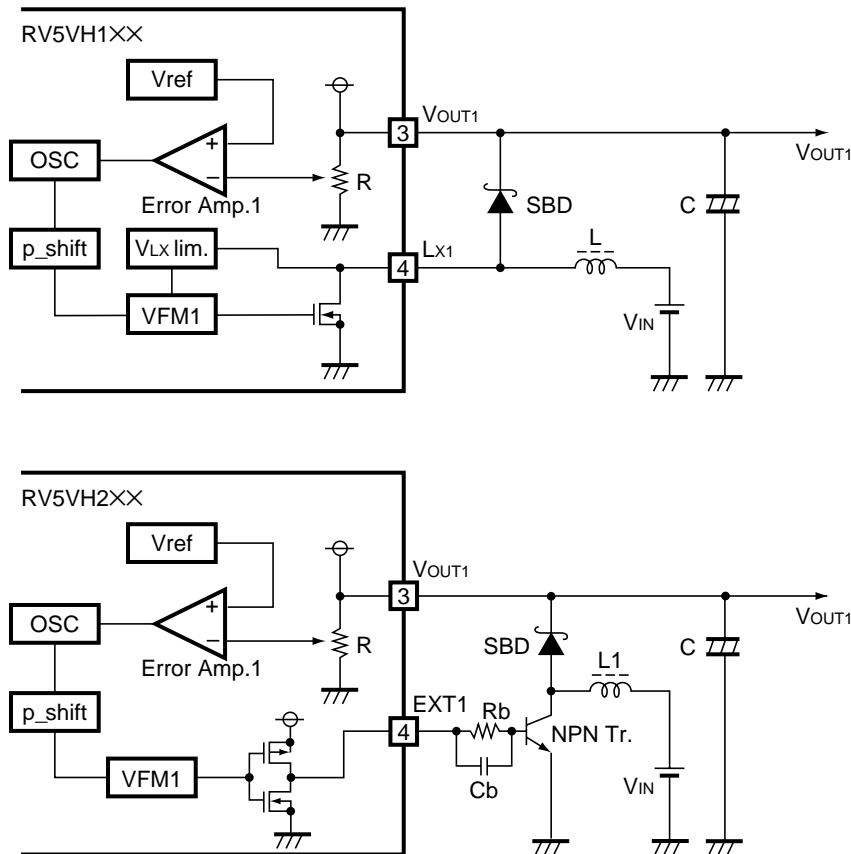

The DC/DC1 uses input voltage as an initial power supply, once boost operation is started, the boost output will be used for the power supply of device itself. A change in the  $V_{OUT1}$  will feed back to the internal error amplifier through external voltage setting resistors and internal feed back resistors. When the feed back voltage is lower than the reference voltage the error amplifier enables oscillation or otherwise will stop oscillation. The internal feed back resistor "R" which is fixed and adjusted by laser trim can make the feed back input voltage to "Error Amp.1" stable. Pulses from the "OSC" circuit have a duty cycle of 50% and it becomes 65 to 75%(at high side) through the "P\_shift" circuit. The duty cycle may be smaller with light load spontaneously.

These clock pulses control VFM circuit and make it possible to operate as a boost converter. The output of LX1 is Nch open drain, while the output of "EXT1" is driven by CMOS buffer and an external NMOS driver is also available instead of an NPN transistor, in such cases the Rb and the Cb are not necessary. A recommended Rb is 300Ω. When you use a MOSFET for the EXT1, the input voltage should be high enough and you can get high efficiency applications.

A current limit is available only for the RV5VH1 series, to prevent an excess current from flowing through Nch driver transistor.

The DC/DC1 can be shut down by CSW pin. When the CSW pin is High,  $V_{DD}$  level, the DC/DC1 is enabled and when the CSW pin is "L", GND level, the DC/DC1 is disabled. The EXT1 pin outputs "L" while the DC/DC1 is disabled.

### • DC/DC Converter 2

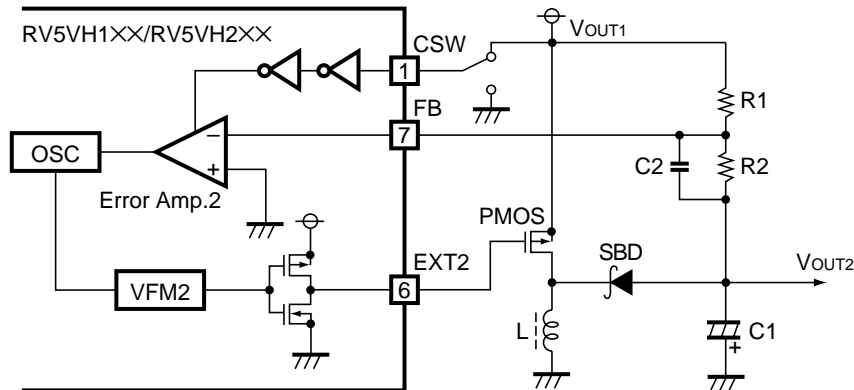

The DC/DC2 can operate by a voltage of “VOUT1”. A change in the VOUT2 will feed back to the internal error amplifier through external voltage setting resistors. The reference voltage should be provided from externally fixed power supply such as VOUT1.

When the feed back voltage to the cmp2 is higher than the ground voltage the error amplifier enables oscillation or otherwise will stop oscillation.

Pulses from the “OSC” circuit have a duty cycle of 50% and it makes VFM operation allowable. There might be certain cases that the duty cycles becomes smaller temporarily at light load current. The output of “EXT2” is driven by CMOS buffer operated VOUT1 and GND.

A PMOS driver will be connected to the “EXT2” pin and its switching operation generates negative output voltage through energy accumulated in an inductor.

The DC/DC1 can be shut down by CSW pin. When the CSW pin is “H”, VDD level, the DC/DC1 is enabled and when the CSW pin is “L”, GND level, the DC/DC1 is disabled. The EXT2 pin outputs High while the DC/DC2 is disabled.

### • Set output voltage DC/DC Converter2

VOUT2 is described as follows:

$$V_{OUT1} : R1 = |-V_{OUT2}| : R2 \quad / \quad \text{The FB voltage is controlled to } 0V \text{ and } V_{OUT1} \text{ is provided externally}$$

$$|-V_{OUT2}| = V_{OUT1} \times R2 / R1$$

thus, any output voltage of DC/DC2 can be set by changing R1 or/and R2.

Certain temperature coefficient of VOUT2 can be set by using R1,R2 having such temperature characteristics.

• Voltage Detector

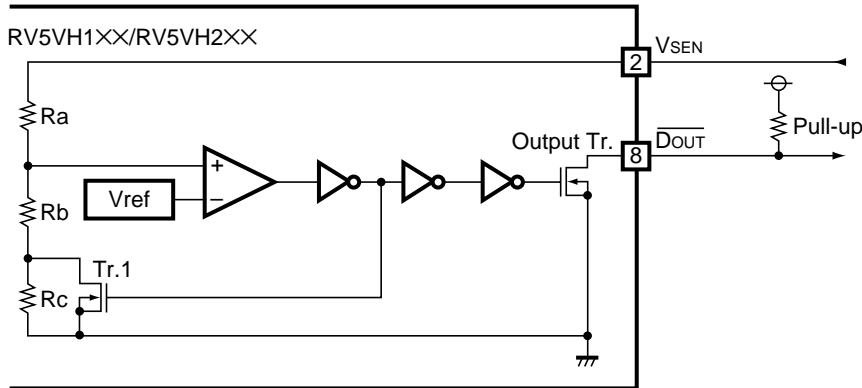

The VD can operate by the voltage of “VOUT1”. The detector threshold and the reset voltage are internally adjusted by trimmed resistors and the VD monitors VSEN pin voltage.

The  $\overline{DOUT}$  is Nch open-drain output and a pull up resistor is necessary.

Operation Diagram

VSEN pin is pulled up to VOUT1 voltage

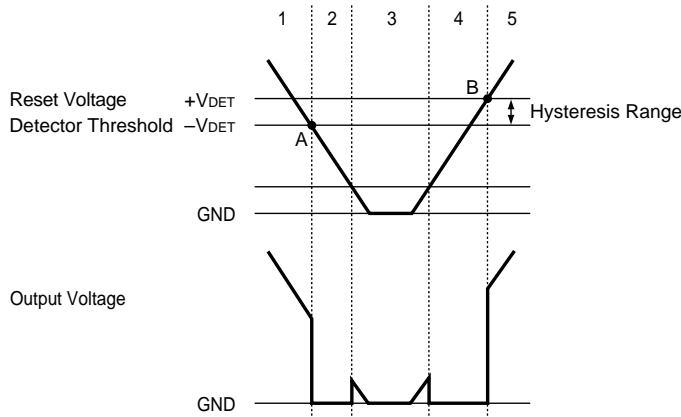

Step	Step 1	Step 2	Step 3	Step 4	Step 5
Comparator(+) Pin Input Voltage	A	B	B	B	A
Comparator Output	H	L	L	L	H
Tr. 1	OFF	ON	ON	ON	OFF
Output Tr	OFF	ON	Indefinite	ON	OFF

$$A : \frac{Rb+Rc}{Ra+Rb+Rc} \times VSEN$$

$$B : \frac{Rb}{Ra+Rb+Rc} \times VSEN$$

Step 1. Output Voltage is equal to Pull-up Voltage.

Step 2. When Input voltage (VSEN) reaches the state of  $Vref \geq VSEN \times (Rb \times Rc) / (Ra + Rb + Rc)$  at point A, the output of the comparator is reversed. so that the output voltage becomes to GND.

Step 3. Output Voltage becomes indefinite when Power source Voltage (VSEN) is smaller than Minimum Operating Voltage. When the output is pulled up, Output becomes pull-up voltage and GND.

Step 4. Output Voltage becomes to GND.

Step 5. When input voltage(VSEN) reaches the state of  $Vref \leq VSEN \times Rb / (Ra + Rb)$  at point B, the output of the comparator is reversed, so that the output voltage becomes to pull-up voltage.

## OPERATION OF STEP-UP DC/DC CONVERTER

Step-up DC/DC Converter charges energy in the inductor when Lx Transistor (LxTr) is on, and discharges the energy with the addition of the energy from Input Power Source thereto, so that a higher output voltage than the input voltage is obtained.

The operation will be explained with reference to the following diagrams :

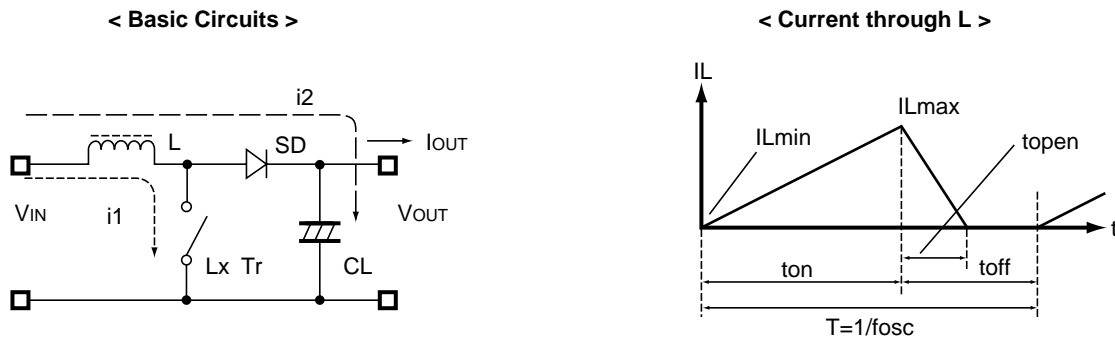

Step 1 : LxTr is turned ON and current  $I_L (=i_1)$  flows, so that energy is charged in L. At this moment,  $I_L (=i_1)$  is increased from  $I_{Lmin} (=0)$  to reach  $I_{Lmax}$  in protection to the on-time period ( $t_{on}$ ) of LxTr.

Step 2 : When LxTr is turned OFF, Schottky diode (SD) is turned on in order that L maintains  $I_L$  at  $I_{Lmax}$ , so that current  $I_L (=i_2)$  is released.

Step 3 :  $I_L (=i_2)$  is gradually decreased, and  $I_L$  reaches  $I_{Lmin} (=0)$  after a time period of  $t_{open}$ , so that SD is turned OFF.

In the case of VFM control system, the output voltage is maintained constant by controlling the oscillator frequency ( $f_{osc}$ ) with the on-time period ( $t_{on}$ ) being maintained constant.

In the above two diagrams, the maximum value ( $I_{Lmax}$ ) and the minimum value ( $I_{Lmin}$ ) of the current which flows through the inductor are the same as those when LxTr is ON and also when LxTr is OFF.

The difference between  $I_{Lmax}$  and  $I_{Lmin}$ , which is represented by  $\Delta I$ , is:

$$\Delta I = I_{Lmax} - I_{Lmin} = V_{IN} \cdot t_{on} / L = (V_{OUT} - V_{IN}) \cdot t_{open} / L \quad \text{.....Equation 1}$$

$$\text{wherein } T = 1/f_{osc} = t_{on} + t_{off}$$

$$\text{duty (\%)} = t_{on} / T \cdot 100 = t_{on} \cdot f_{osc} \cdot 100$$

$$t_{open} \leq t_{off}$$

In Equation 1,  $V_{IN} \cdot t_{on} / L$  and  $(V_{OUT} - V_{IN}) \cdot t_{open} / L$  are respectively the change in the current at ON, and the change in the current at OFF.

In the VFM system,  $t_{open} < t_{off}$  as illustrated in the above diagram. In this case, the energy charged in the inductor during the time period of  $t_{on}$  is discharged in its entirety during the time period of  $t_{off}$ , so that  $I_{Lmin}$  becomes zero ( $I_{Lmin} = 0$ ).

## SELECTION OF PERIPHERAL COMPONENTS

When LxTr is on, the energy PON charged in the inductor is provided by Equation 2 as follows :

$$\begin{aligned} \text{PON} &= \int_0^{\text{ton}} (\text{VIN} \cdot \text{IL} (t)) dt = \int_0^{\text{ton}} (\text{VIN}^2 \cdot t/L) dt \\ &= \text{VIN}^2 \cdot \text{ton}^2 / (2 \cdot L) \dots \dots \dots \text{Equation 2} \end{aligned}$$

In the case of the step-up DC/DC converter, the energy is also supplied from the input power source at the time of OFF.

$$\begin{aligned} \text{Thus, POFF} &= \int_0^{\text{topen}} (\text{VIN} \cdot \text{IL} (t)) dt = \int_0^{\text{topen}} (\text{VIN} \cdot (\text{VOUT} - \text{VIN}) \cdot t/L) dt \\ &= \text{VIN} \cdot (\text{VOUT} - \text{VIN}) \cdot \text{topen}^2 / (2 \cdot L) \end{aligned}$$

Here, topen = VIN · ton / (VOUT - VIN) from Equation 1, and when this is substituted into the above equation.

$$= \text{VIN}^3 \cdot \text{ton}^2 / (2 \cdot L \cdot (\text{VOUT} - \text{VIN})) \dots \dots \dots \text{Equation 3}$$

Input power PIN is (PON+POFF)/T. When this is converted in its entirety to the output.

$$\text{PIN} = (\text{PON} + \text{POFF}) / T = \text{VOUT} \cdot \text{IOUT} = \text{POUT} \dots \dots \dots \text{Equation 4}$$

Equation 5 can be obtained as follows by solving Equation 4 for IOUT by substituting Equation 2 and 3 into Equation 4 :

$$\begin{aligned} \text{IOUT} &= \text{VIN}^2 \cdot \text{ton}^2 / (2 \cdot L \cdot T \cdot (\text{VOUT} - \text{VIN})) \\ &= \text{VIN}^2 \cdot \text{maxdty}^2 / (20000 \cdot \text{fosc} \cdot L \cdot (\text{VOUT} - \text{VIN})) \dots \dots \dots \text{Equation 5} \end{aligned}$$

The peak current which flows through L · LxTr · SD is

$$\text{ILmax} = \text{VIN} \cdot \text{ton} / L \dots \dots \dots \text{Equation 6}$$

Therefore, it is necessary that the setting of the input/output conditions and the selection of peripheral components be made with ILmax taken into consideration.

### HINTS

The above explanation is directed to the calculation in an ideal case where it is supposed that there is no energy loss in the external components and LxSW. In an actual case, the maximum output current will be 50 to 80% of the above calculated maximum output current. In particular, care must be taken because VIN is decreased in an amount corresponding to the voltage reduction caused by LxSW when IL is large or VIN is small. Furthermore, It is required that with respect to VOUT, Vf of the diode (about 0.3V in the case of a Schottky type diode) be taken into consideration.

When ILX and VLX exceed their respective ratings, use the RV5VH with the attachment of an external transistor with a low saturation voltage thereto.

## TYPICAL APPLICATION

### • RV5VH1XX

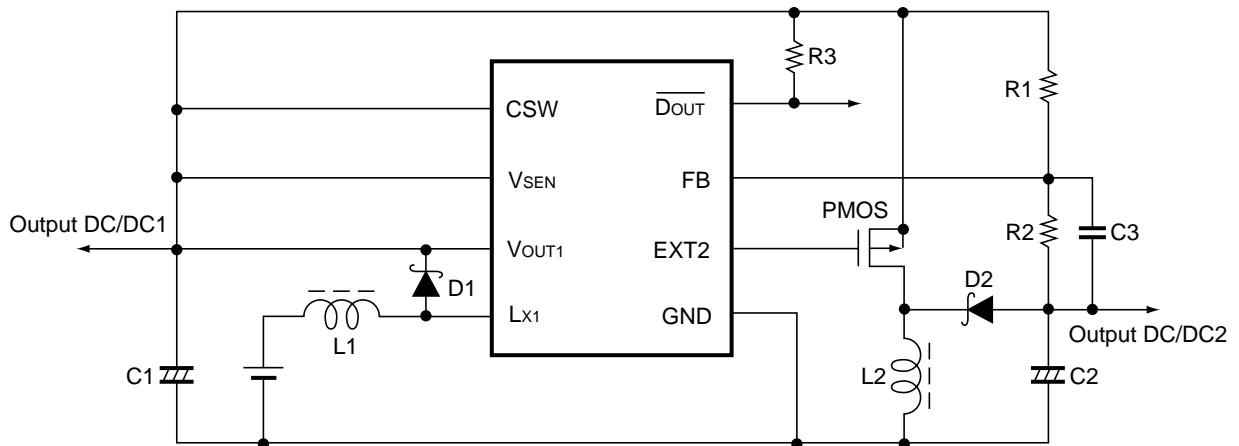

<Components>	Coils	L1 : 100 $\mu$ H, L2 : 220 $\mu$ H
	Diodes	Schottky type
	Capacitors	C1, C2 : 22 $\mu$ F(tantalum type), C3 : 0.01 $\mu$ F(ceramic type)
	Tr	PMOS : 2SJ238
	Resistors	R1, R2 : several hundreds k $\Omega$ , R3 : 100k $\Omega$

### • RV5VH2XX

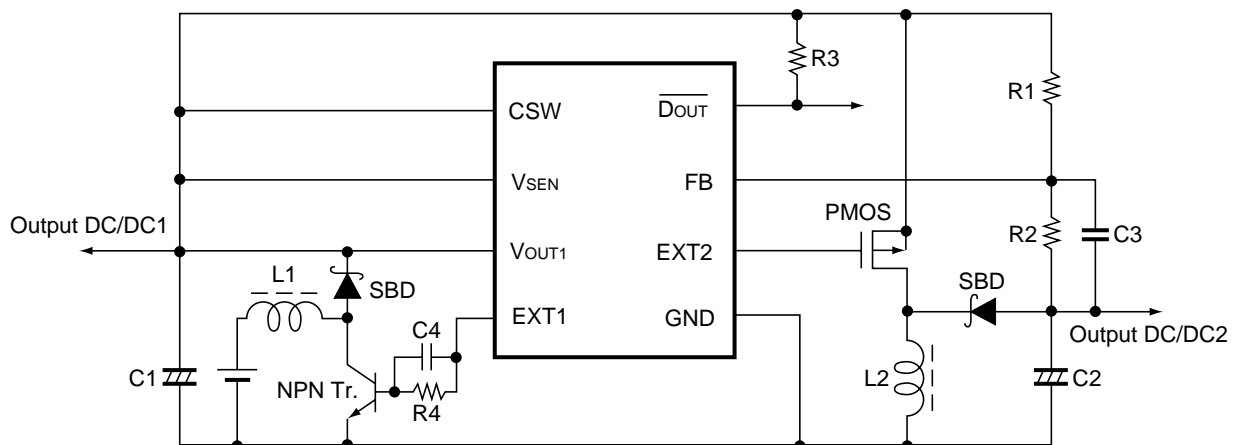

<Components>	Coils	L1 : 27 $\mu$ H, L2 : 220 $\mu$ H
	Diodes	Schottky type
	Capacitors	C1 : 47 $\mu$ F(tantalum type), C2 : 22 $\mu$ F(tantalum type) C3 : 0.01 $\mu$ F(ceramic type) C4 : 0.01 $\mu$ F(ceramic type)
	PMOS	2SJ238(TOSHIBA), etc.
	NPN Tr.	2SD1628G(SANYO), etc.
	Resistors	R1 : 100K $\Omega$ R2 : 0-500K $\Omega$ R3 : 100K $\Omega$ R4 : 300 $\Omega$



# TEST CIRCUITS

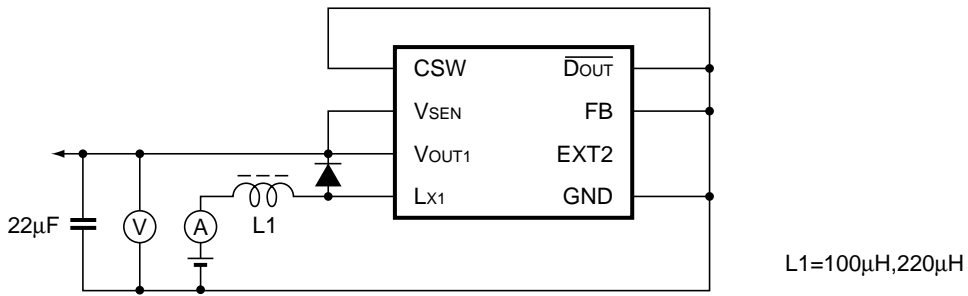

Fig.1 Test Circuit 1

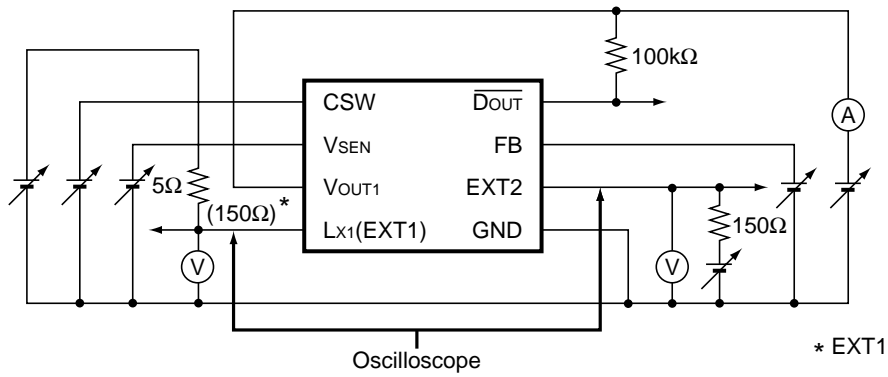

Fig.2 Test Circuit 2

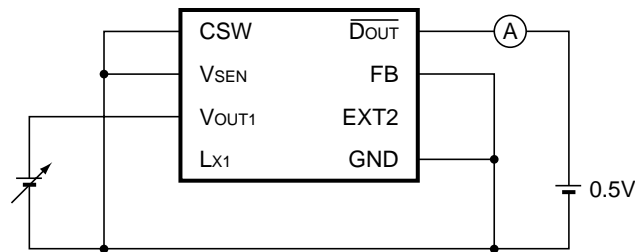

Fig.3 Test Circuit 3

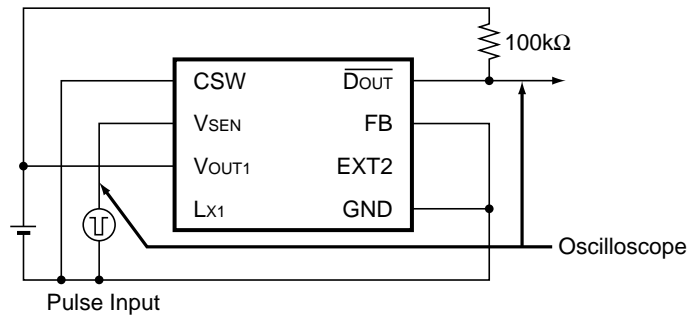

Fig.4 Test Circuit 4

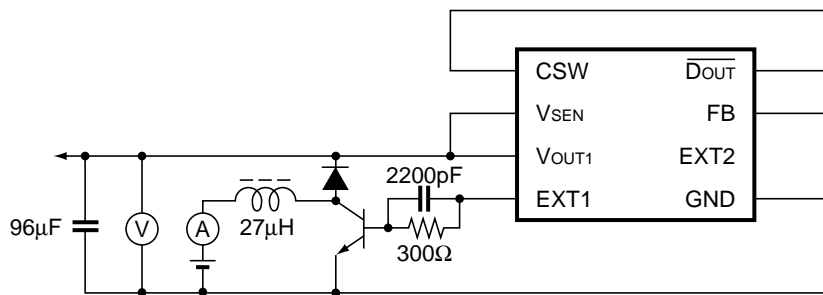

Fig.5 Test Circuit 5

- Test Circuit 1: Typical Characteristics 1), 3), 5), 10), 11)  
 Test Circuit 2: Typical Characteristics 6), 7), 8), 9), 13), 14), 15), 16), 17), 18), 19), 21)  
 Test Circuit 3: Typical Characteristics 20)  
 Test Circuit 4: Typical Characteristics 22)  
 Test Circuit 5: Typical Characteristics 2), 4)  
 Typical Application : Typical Characteristics 12)

# TYPICAL CHARACTERISTICS

## • DC/DC Converter 1

### 1) Output Voltage vs. Output Current (RV5VH1XX)

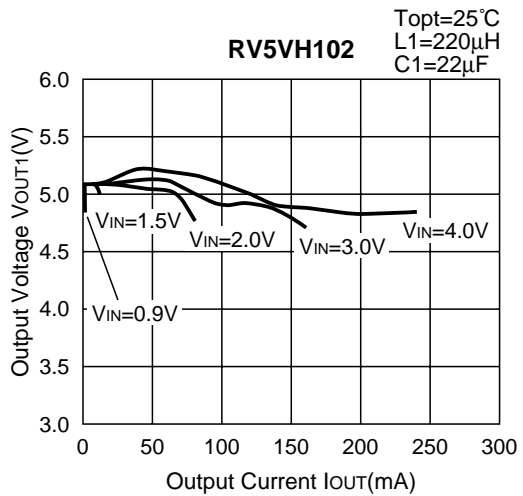
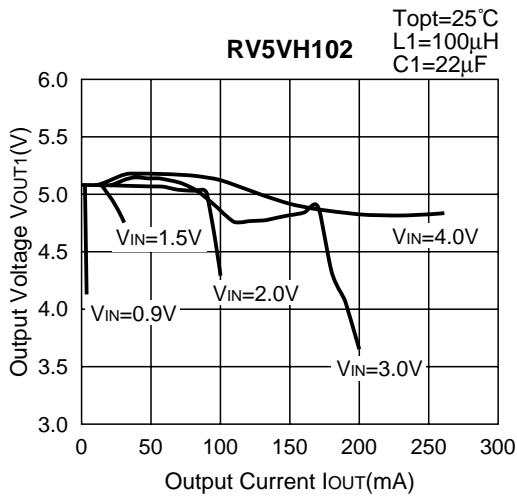
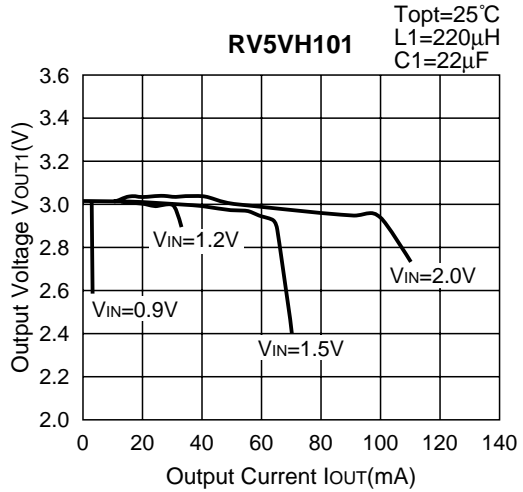
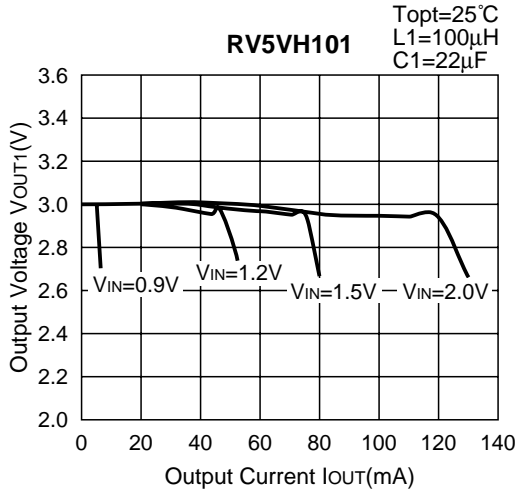

### 2) Output Voltage vs. Output Current (RV5VH2XX)

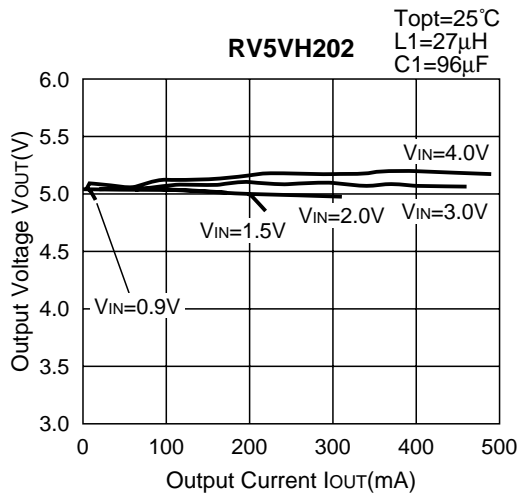
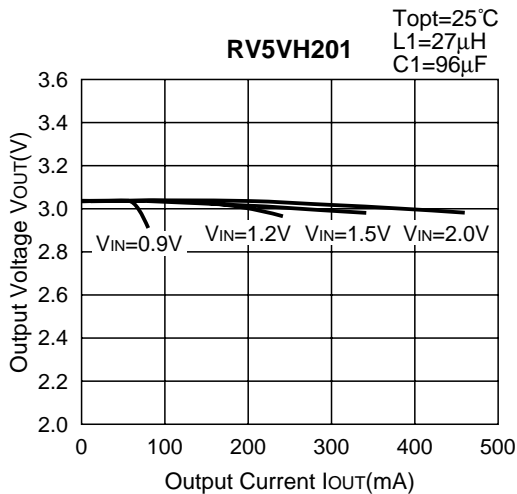

3) Efficiency vs. Output Current (RV5VH1XX)

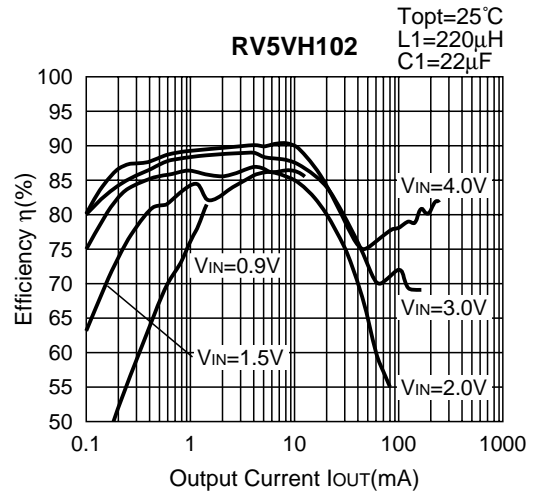
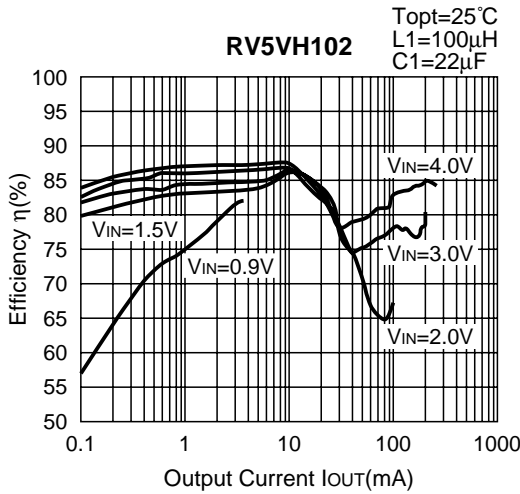
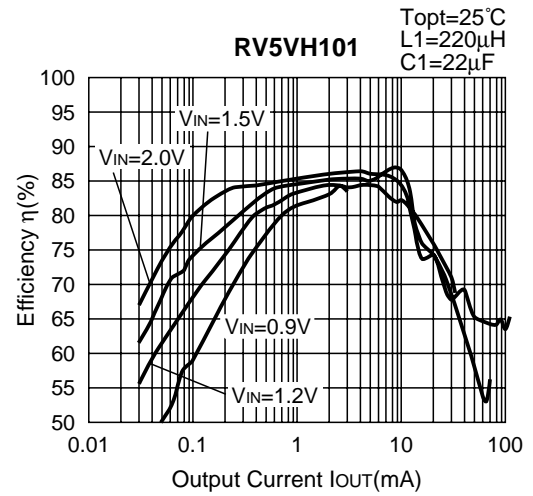
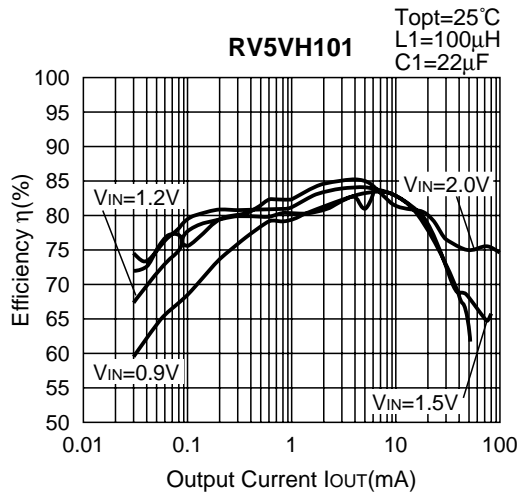

4) Efficiency vs. Output Current (RV5VH2XX)

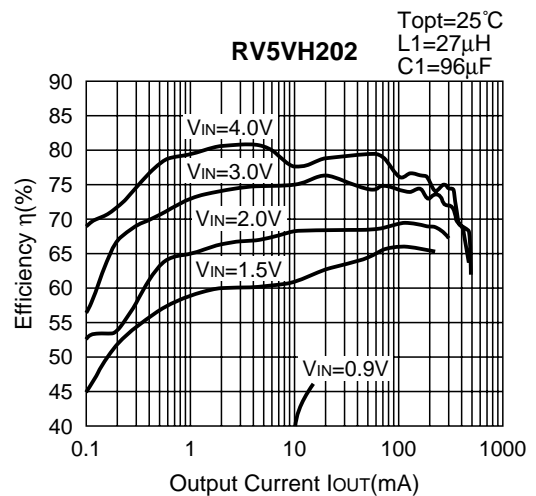
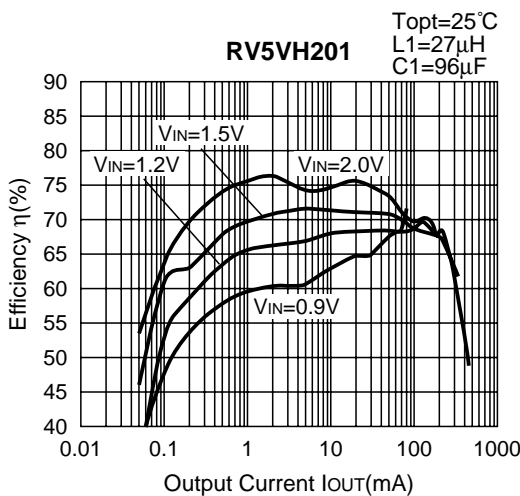

5) DC/DC1 Output Voltage vs. Temperature

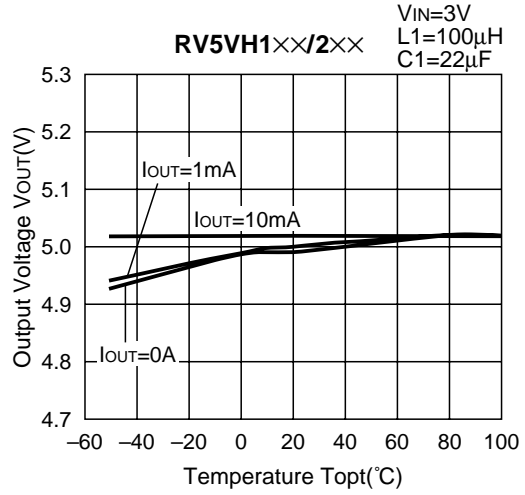
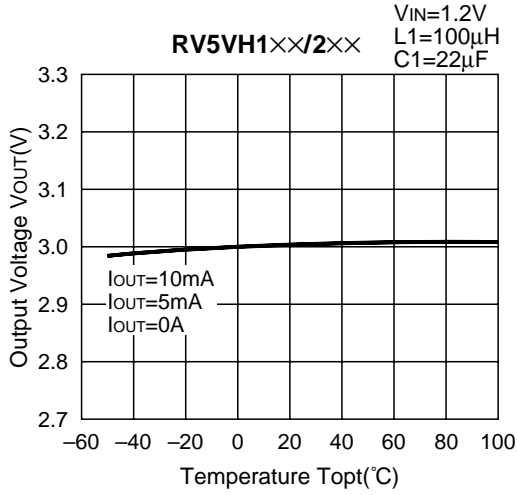

6) Oscillator Frequency vs. Temperature

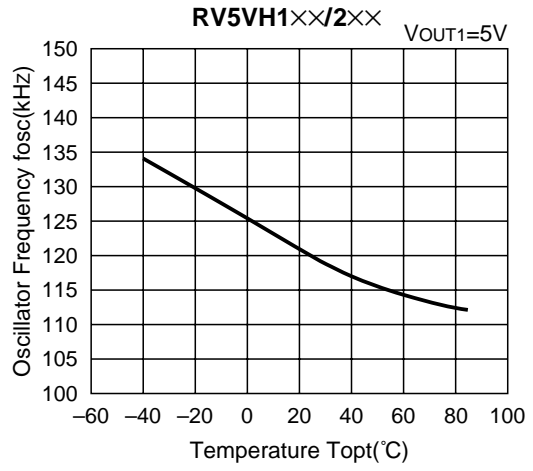
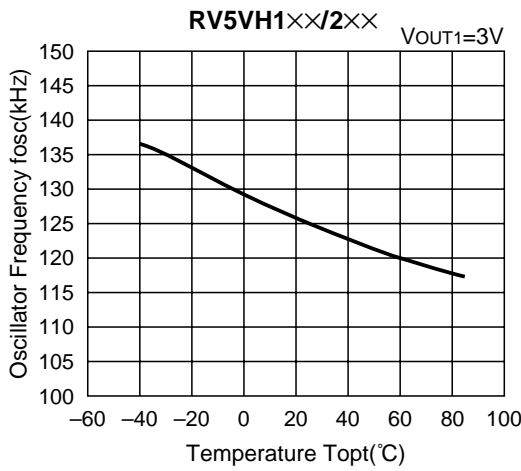

7) Oscillator Duty Cycle vs. Temperature

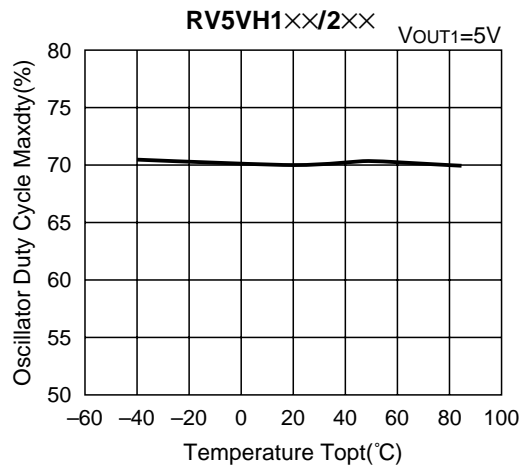
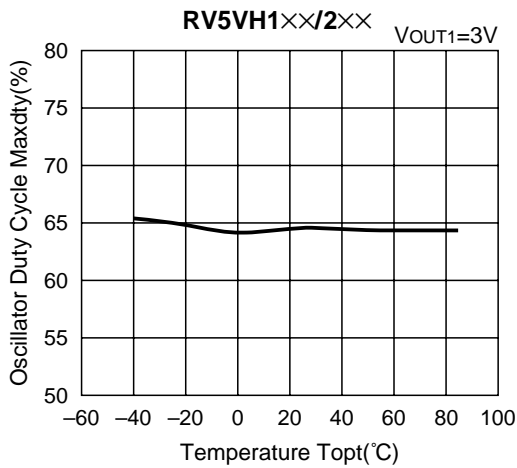

8) On Resistance of LX vs. Supply Voltage

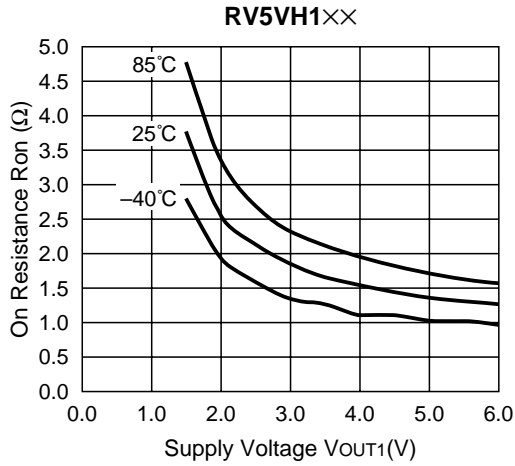

9) EXT1 Output Current vs. Temperature

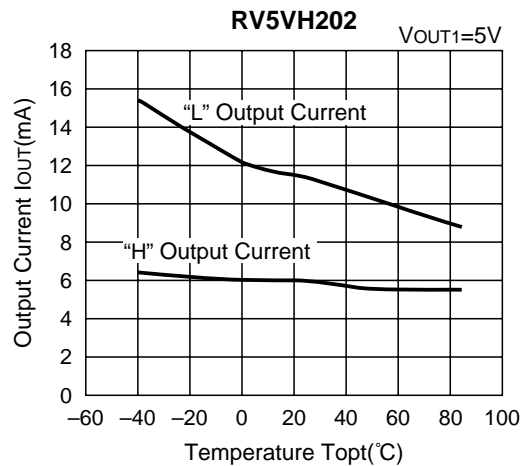
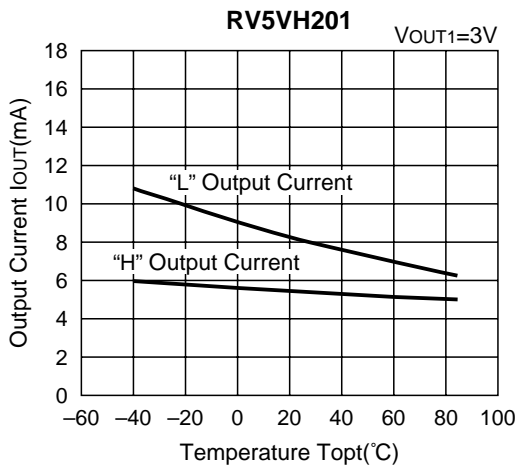

10) Start-up/Hold-on Voltage vs. Output Current

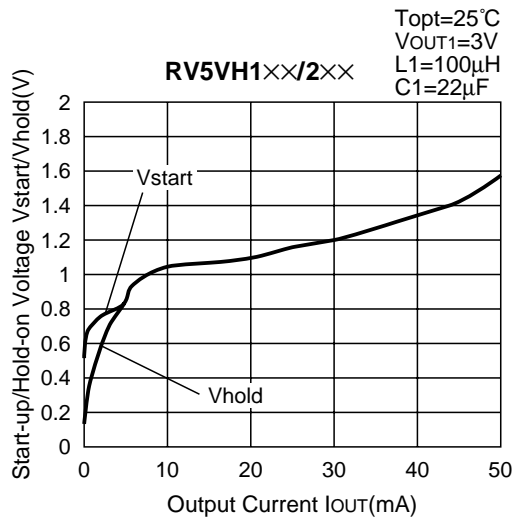

11) Input Current vs. Input Voltage

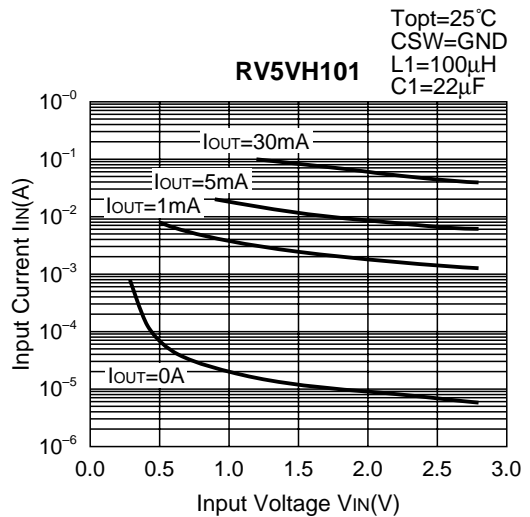

• DC/DC Converter 2

12) Output Voltage vs. Output Current

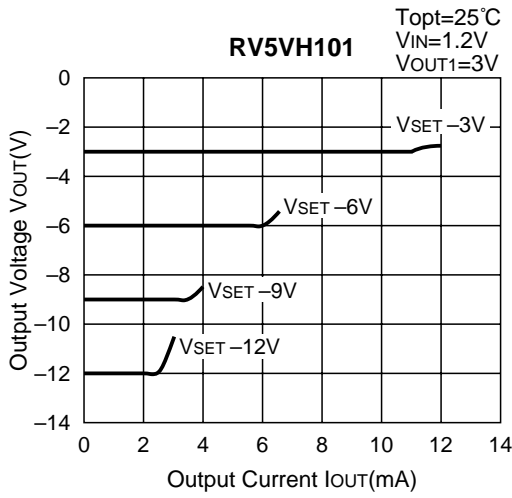

13) DC/DC2 Feed Back Voltage vs. Temperature

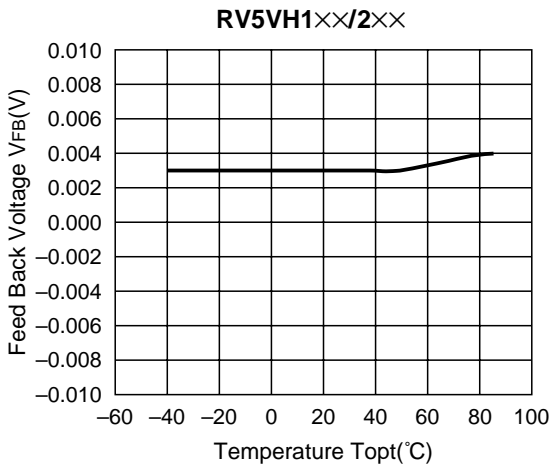

14) EXT2 Output Current vs. Temperature

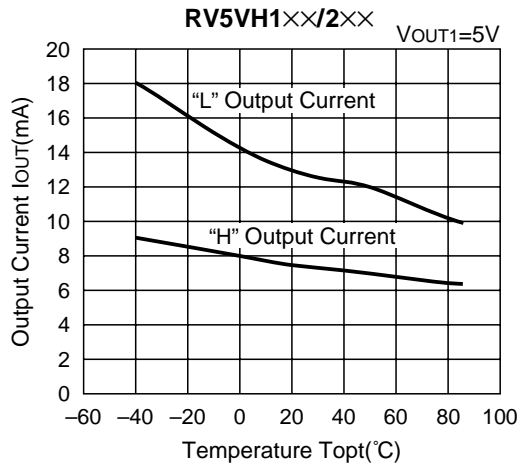
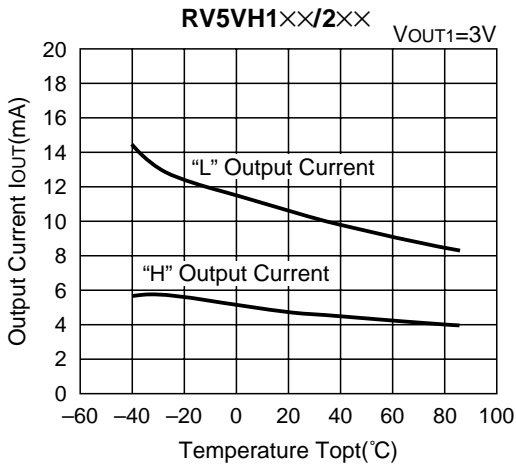

15) EXT2 Oscillator Frequency vs. Temperature

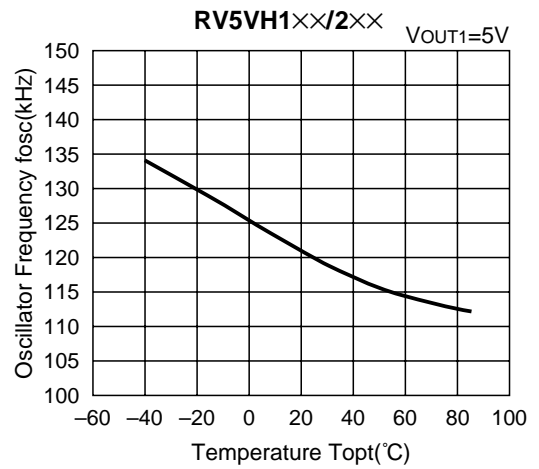
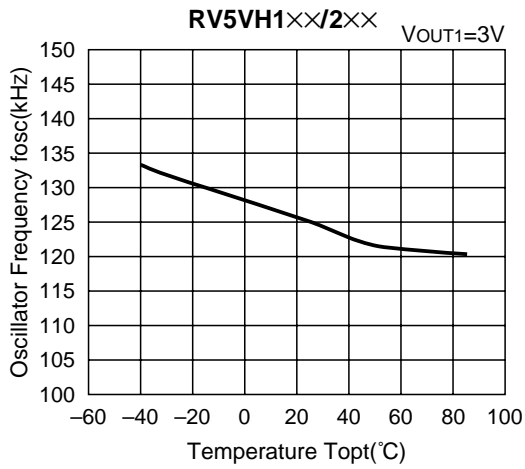

16) EXT2 Oscillator Duty Cycle vs. Temperature

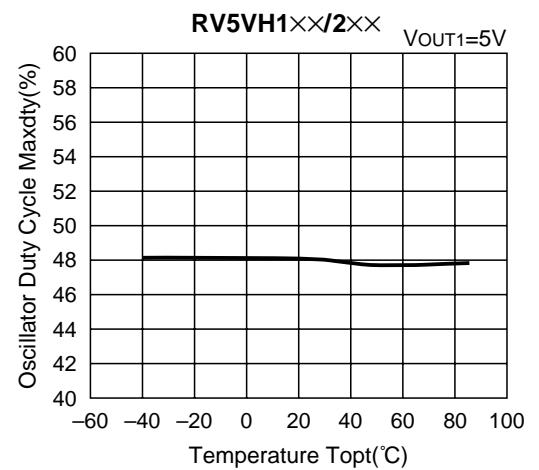
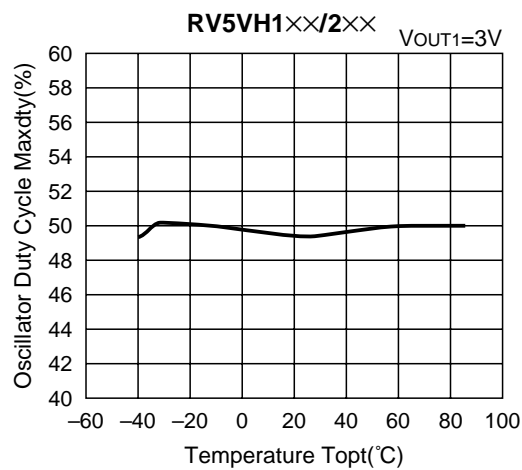

17) CSW ON/OFF Voltage vs. Temperature

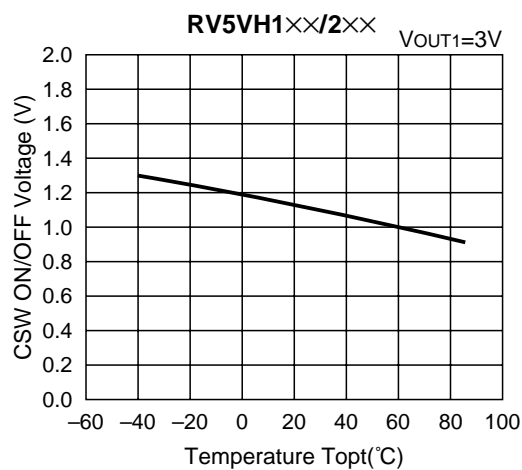



• Voltage Detector

18) Detector Threshold Voltage vs. Temperature

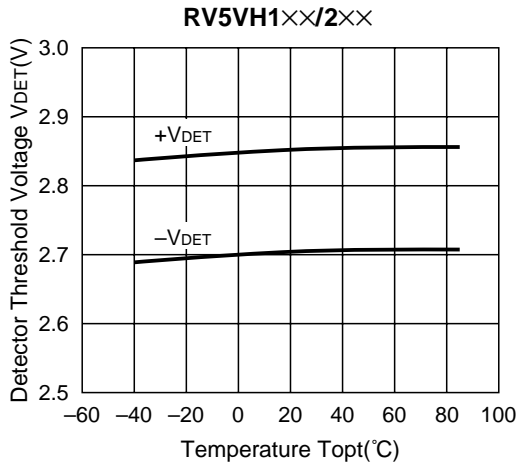

19) VOUT1 Output Voltage vs. Output Current

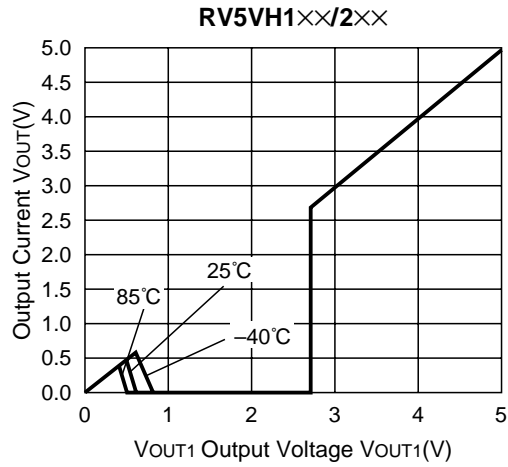

20) DOUT Output Current vs. VOUT1 Output Voltage

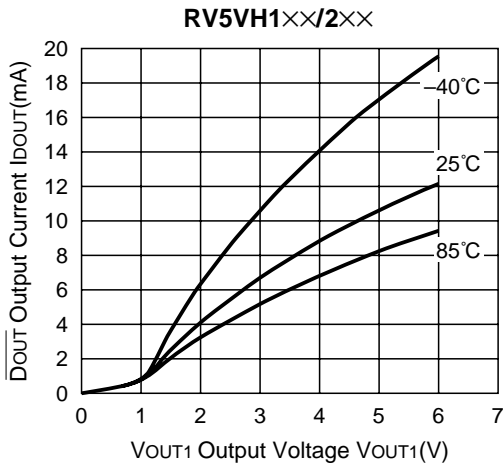

21) VSEN Output Current vs. VSEN Output Voltage

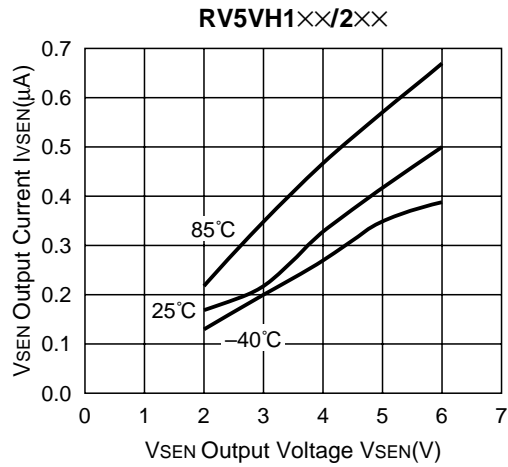

22) Output Delay Time vs. Load Capacitance

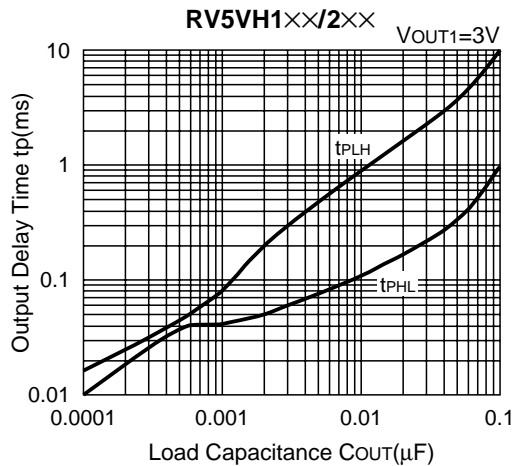

### BLOCK DIAGRAM

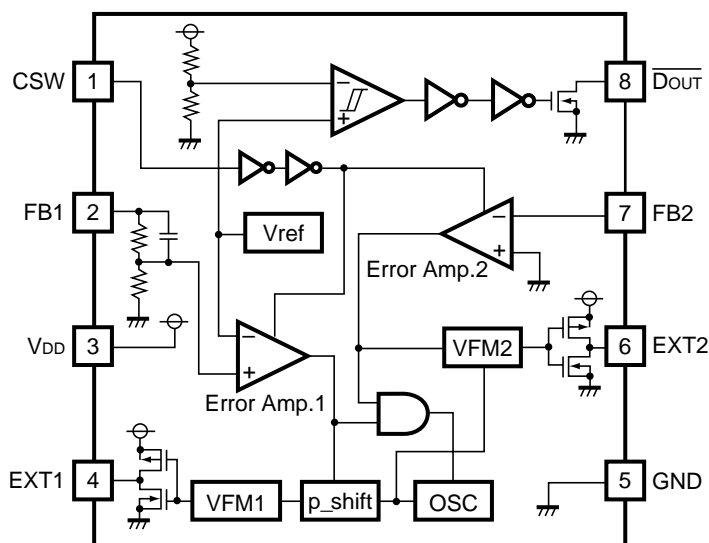

### PIN CONFIGURATION

• 8 pin SSOP (0.65mm pitch)

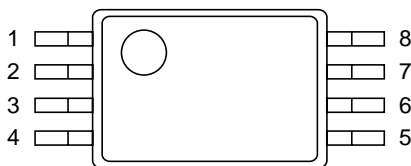

## PIN DESCRIPTION

Pin No.	Symbol	Description
1	CSW	Control Switch for DC/DC1, 2
2	FB1	Input for DC/DC1 Error Amplifier
3	VDD	Power Supply for Device Itself. Sensing Pin for Reset.
4	EXT1	External Transistor Drive Pin for DC/DC1 (CMOS Output)
5	GND	Ground Pin
6	EXT2	External Transistor Drive Pin for DC/DC2 (CMOS Output)
7	FB2	Input for DC/DC2 Error Amplifier
8	$\overline{\text{DOUT}}$	Output for Voltage Detector

## ABSOLUTE MAXIMUM RATINGS

GND=0V

Symbol	Item	Ratings	Unit
VDD	VDD Pin Voltage	12	V
DOUT	$\overline{\text{DOUT}}$ Pin Voltage	12	V
VCSW	CSW Pin Voltage	-0.3 to VDD+0.3	V
VEXT1,2	EXT1, 2 Pin Voltage	-0.3 to VDD+0.3	V
VFB	FB1,2 Pin Voltage	-0.3 to VDD+0.3	V
IEXT1,2	EXT1, 2 Output Current	±50	mA
PD	Power Dissipation	300	mΩ
Topt	Operating Temperature	-40 to +85	°C
Tstg	Storage Temperature	-55 to +125	°C
Tsolder	Lead Temperature (Soldering)	260°C 10sec	

### ABSOLUTE MAXIMUM RATINGS

Absolute Maximum ratings are threshold limit values that must not be exceeded even for an instant under any conditions. Moreover, such values for any two items must not be reached simultaneously. Operation above these absolute maximum ratings may cause degradation or permanent damage to the device. These are stress ratings only and do not necessarily imply functional operation below these limits.

## ELECTRICAL CHARACTERISTICS

### • RV5VH301

DC/DC Converter 1

V<sub>DD</sub>=3.0V, T<sub>opt</sub>=25°C

Symbol	Item	Conditions	MIN.	TYP.	MAX.	Unit
VSET1	Output Voltage Setting 1		2.05		*1	V
VFB1	Feed Back Volatage 1		1.950	2.000	2.050	V
VINmax	Maximum Input Voltage				10	V
VOPTmin	Minimum Operating Voltage	Specified as a V <sub>DD</sub> Voltage for Device Operation			1.8	V
ISS11	Supply Current11*2	CSW="H", FB1=1.9V		15	60	μA
ISS12	Supply Current12*2	CSW="H", FB1=2.1V		4		μA
Istandby	Standby Current*3	CSW="L"		4	11	μA
IEXT1H	EXT1 "H" Output Current	VEXT1=V <sub>DD</sub> -0.4V	1.5	3		mA
IEXT1L	EXT1 "L" Output Current	VEXT1=0.4V	4	8		mA
fosc	Maximum Oscillator Frequency		110	130	150	kHz
Maxdty	Oscillator Duty Cycle	ON (VEXT1="L")	50	65	80	%
$\frac{\Delta V_{FB1}}{\Delta T_{opt}}$	Feed Back Voltage Temp.Coefficient	-40°C≤T <sub>opt</sub> ≤85°C		±100		ppm/°C
VCSWH	CSW "H" Input Voltage		1.6		V <sub>DD</sub>	V
VCSWL	CSW "L" Input Voltage		0		0.4	V
Icswleak	CSW Input Leakage Current	CSW=3.0V or CSW=0V	-0.5		0.5	μA

\* ) V<sub>DD</sub>=3.0V, I<sub>OUT</sub>=10mA : unless otherwise specified. (See Typical Application)

\*1 ) Adjustable by external resistors (to 30V).

\*2 ) Supply current for DC/DC1. Supply current for VD or external resistors are excluded.

\*3 ) Standby current includes supply current for DC/DC1, 2 and VD.

## DC/DC Converter 2

V<sub>DD</sub>=3.0V, T<sub>opt</sub>=25°C

Symbol	Item	Conditions	MIN.	TYP.	MAX.	Unit
VSET2	Output Voltage Setting 1		*1		0	V
VFB2	Feed Back Volatage 1		-20	0	20	mV
VINmax	Maximum Input Voltage				10	V
VOPTmin	Minimum Operating Voltage	Specified as the V <sub>DD</sub> Voltage for Device Operation			1.8	V
ISS21	Supply Current21*2	CSW="H", FB2=0.1V		15	60	μA
ISS22	Supply Current22*2	CSW="H", FB2=-0.1V		4		μA
IEXT2H	EXT2 "H" Output Current	V <sub>EXT2</sub> =V <sub>DD</sub> -0.4V	2	4		mA
IEXT2L	EXT2 "L" Output Current	V <sub>EXT2</sub> =0.4V	4	8		mA
fosc	Maximum Oscillator Frequency		110	130	150	kHz
Maxdty	Oscillator Duty Cycle	ON (V <sub>EXT2</sub> ="L")	40	50	60	%
$\frac{\Delta V_{FB2}}{\Delta T_{opt}}$	Feed Back Voltage Temp.Coefficient	-40°C≤T <sub>opt</sub> ≤85°C		±30		μV/°C

\* ) V<sub>DD</sub>=3.0V : unless otherwise specified. (See Typical Application)

\*1 ) Adjustable by external resistors (to -30V).

\*2 ) This value shows only the supply current of DC/DC2, not include the supply current of external resistors.

## Voltage Detector

V<sub>DD</sub>=3.0V, T<sub>opt</sub>=25°C

Symbol	Item	Conditions	MIN.	TYP.	MAX.	Unit
V <sub>DET</sub>	Detector Threshold		2.633	2.700	2.767	V
V <sub>HYS</sub>	Detector Threshold Hysteresis		0.081	0.135	0.189	V
I <sub>SS3</sub>	Supply Current <sup>3*1</sup>			1.2		μA
V <sub>INmax</sub>	Maximum Input Voltage				10	V
V <sub>OPTmin</sub>	Minimum Operating Voltage	Specified as the V <sub>DD</sub> Voltage for Device Operation			1.8	V
I <sub>OUT</sub>	Output Current	V <sub>DS</sub> =0.5V, V <sub>DD</sub> =1.5V	1.0	2.0		mA
		V <sub>DS</sub> =0.5V, V <sub>DD</sub> =3.0V	4.0	5.0		mA
t <sub>PLH</sub>	Output Delay				100	μs
$\frac{\Delta V_{OUT1}}{\Delta T_{opt}}$	Detector Threshold Temp.Coefficient	-40°C ≤ T <sub>opt</sub> ≤ 85°C		±100		ppm/°C
I <sub>DOUtleak</sub>	DOUT Leakage Current			0.03	0.5	μA

\* ) V<sub>DD</sub>=3.0V : unless otherwise specified.

\*1 ) This value only shows the supply current of voltage detector.

## OPERATION

### • DC/DC Converter 1

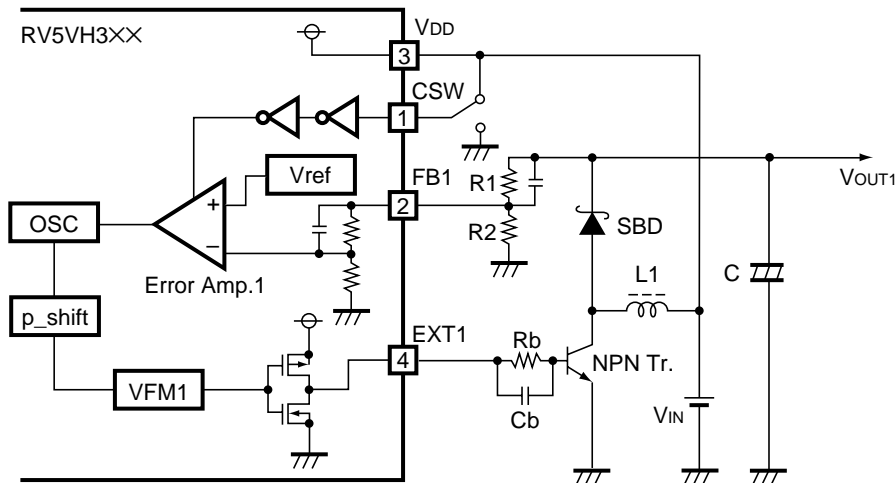

The DC/DC1 can operate by an input voltage to the VDD pin. A change in the VOUT1 will feed back to the internal error amplifier through external voltage setting resistors and internal feed back resistors. When the feed back voltage is lower than the reference voltage, the error amplifier enables oscillation or otherwise, it will stop oscillation. The internal feed back resistor “R” which is fixed and adjusted by laser trim can make the feed back input voltage to “Error Amp.1” stable.

Pulses from the “OSC” circuit have a duty cycle of 50% and it becomes 65 to 75%(at high side) through the “P\_shift” circuit. These clock pulses control VFM circuit and make it possible to operate as a boost converter.

The output of “EXT1” is driven by CMOS buffer and an external NMOS driver is also available instead of an NPN transistor, in such cases the Rb and the Cb are not necessary. The DC/DC1 can be shut down by CSW pin. When the CSW pin is “H”, VDD level, the DC/DC1 is enabled and when the CSW pin is “L”, GND level, the DC/DC1 is disabled. The EXT1 pin outputs “L” while the DC/DC1 is disabled.

### • Set Output Voltage DC/DC1

VOUT1 is described as follows :

$V_{OUT1} : R1+R2=V_{FB1} : R2$       DC/DC1 controls VFB1 to be a constant voltage,

$V_{OUT1}=V_{FB1} \times (R1+R2) / R2$

thus, any output voltage of DC/DC1 can be set by changing R1 or/and R2.

Certain temperature coefficient of VOUT1 can be set by using R1, R2 having such temperature characteristics.

## • DC/DC Converter 2

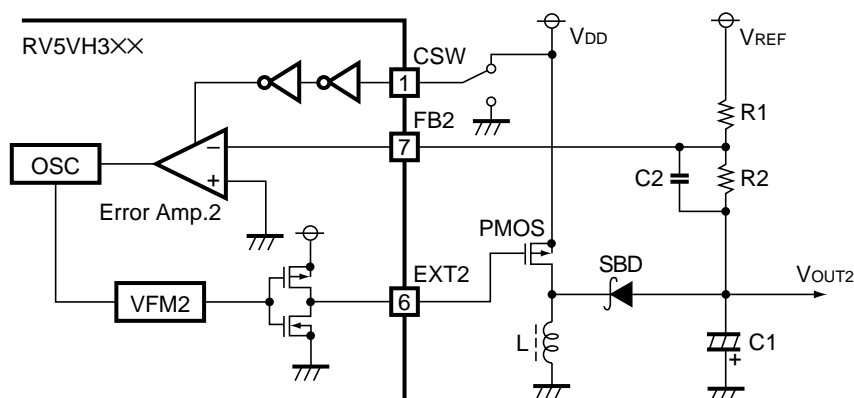

The DC/DC2 can operate by an input voltage to the  $V_{DD}$  pin. A change in the  $V_{OUT2}$  will feed back to the internal error amplifier through external voltage setting resistors. The  $V_{REF}$  voltage should be provided from externally fixed power supply such as  $V_{OUT1}$ .

When the feed back voltage to the Error Amp.2 is higher than the ground voltage, the error amplifier enables oscillation otherwise, it will stop oscillation.

Pulses from the “OSC” circuit have a duty cycle of 50% and it makes VFM operation allowable.

There might be certain cases that the duty cycles become smaller temporarily at light load current. The output of “EXT2” is driven by CMOS buffer operated  $V_{DD}$  and GND.

A PMOS driver will be connected to the “EXT2” pin and its switching operation generates negative output voltage through energy accumulated in an inductor.

The DC/DC1 can be shut down by CSW pin. When the CSW pin is High,  $V_{DD}$  level, the DC/DC1 is enabled and when the CSW pin is “L”, GND level, the DC/DC1 is disabled. The EXT2 pin outputs “H” while the DC/DC2 is disabled.

## • Set Output Voltage DC/DC 2

$V_{OUT2}$  is described as follows:

$V_{REF} : R1 = |-V_{OUT2}| : R2$  The FB2 voltage is controlled to 0V and  $V_{REF}$  is provided externally  
 $|-V_{OUT2}| = V_{REF} \times R2 / R1$ ,

thus, any output voltage of DC/DC2 can be set by R1 and R2.

Certain temperature coefficient of  $V_{OUT2}$  can be set by using R1, R2 having such temperature characteristics.



• Voltage Detector

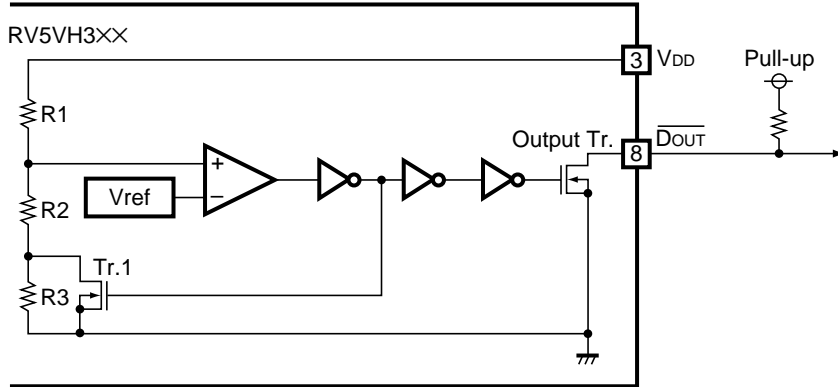

The Voltage Detector can operate by an input voltage to the VDD pin. The detector threshold and the reset voltage are internally adjusted by trimmed resistors and the VD monitors VDD pin voltage. The DOUT is Nch open-drain output and a pull up resistor is necessary.

Operation Diagram

The output is pulled up to VDD voltage

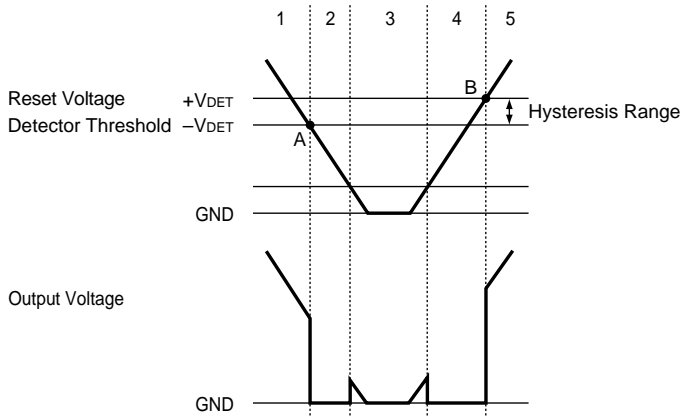

Step	Step 1	Step 2	Step 3	Step 4	Step 5
Comparator(+) Pin Input Voltage	A	B	B	B	A
Comparator Output	H	L	L	L	H
Tr. 1	OFF	ON	ON	ON	OFF
Output Tr.	OFF	ON	Indefinite	ON	OFF

$$A : \frac{R2+R3}{R1+R2+R3} \times VDD$$

$$B : \frac{R2}{R1+R2+R3} \times VDD$$

Step 1. Output Voltage is equal to Pull-up Voltage

Step 2. When Input voltage(VDD) reaches to the state of  $VREF \geq VDD \times (R2+R3)/(R1+R2+R3)$  at point A, the output of the comparator is reversed, so that the output voltage becomes to GND.

Step 3. Output Voltage becomes indefinite when Power Source Voltage (VDD) is smaller than Minimum Operating Voltage. When the output is pulled up, Output becomes pull-up voltage and GND.

Step 4. Output Voltage becomes to GND.

Step 5. When Input voltage(VDD) reaches to the state of  $VREF \leq VDD \times R2/(R1+R2)$  at point B, the output of the comparator is reversed, so that the output voltage becomes to pull-up voltage.

## TYPICAL APPLICATION 1

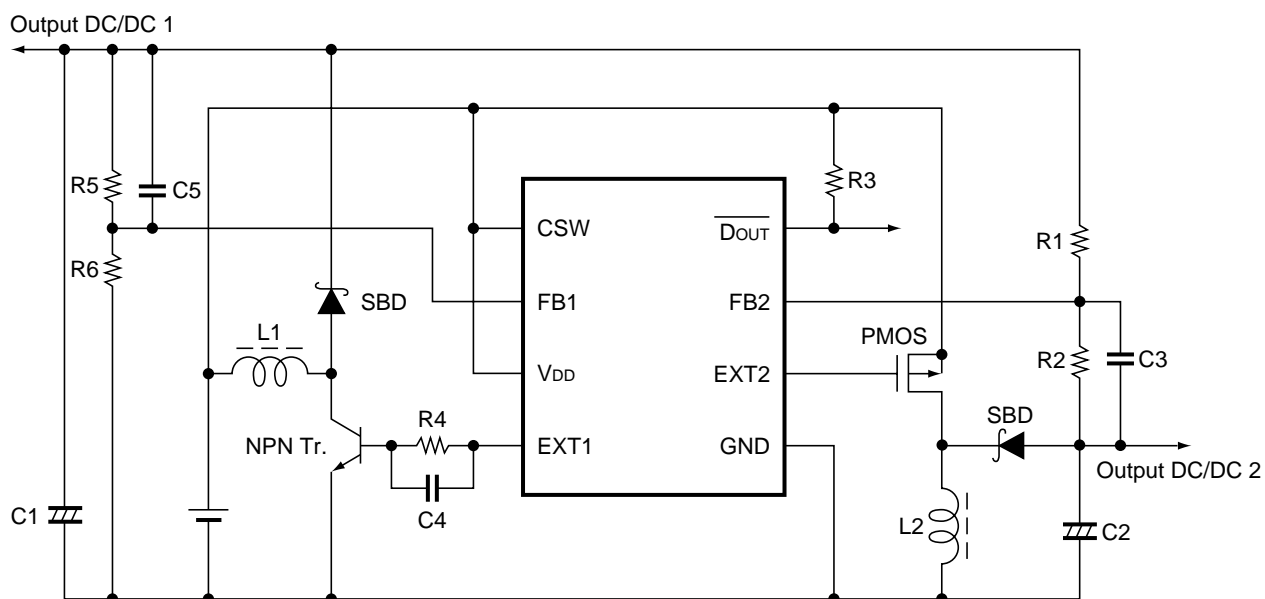

Coil	L1 : 100 $\mu$ H, L2 : 100 $\mu$ H
Diode	Schottky type
capacitor	C1 : 22 $\mu$ F(Ta), C2 : 22 $\mu$ F(Ta) C3 : 0.01 $\mu$ F (ceramic) C4 : 0.01 $\mu$ F (ceramic) C5 : 0.01 $\mu$ F (ceramic)
PMOS	2SJ238 (TOSHIBA)
NMOS	2SK1470 (SANYO)
Resistor	R1 : 100k $\Omega$ , R2 : 0 to 500k $\Omega$ R3 : 100k $\Omega$ R4 : 300 $\Omega$ R5 : 0 to 500k $\Omega$ , R6 : 50k $\Omega$

## TYPICAL APPLICATION 2

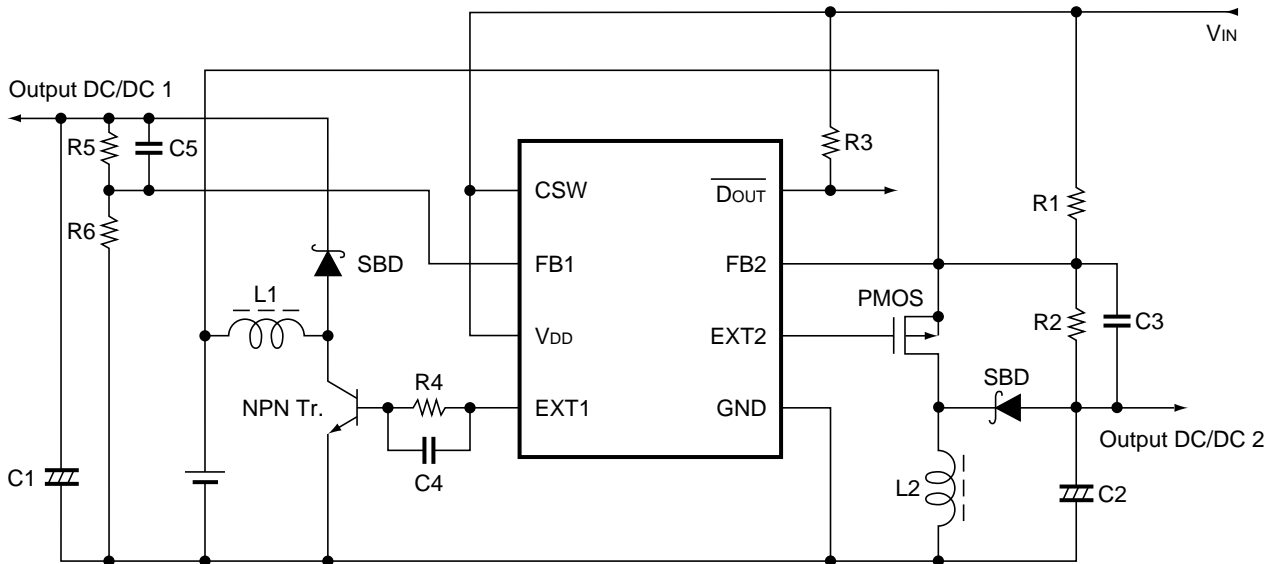

Coil	L1 : 100 $\mu$ H, L2 : 100 $\mu$ H
Diode	Schottky type
capacitor	C1 : 22 $\mu$ F (Ta), C2 : 22 $\mu$ F (Ta)
	C3 : 0.01 $\mu$ F (ceramic)
	C4 : 0.01 $\mu$ F (ceramic)
	C5 : 0.01 $\mu$ F (ceramic)
PMOS	2SJ238 (TOSHIBA)
NPN Tr.	2SD1628G (SANYO)
Resistor	R1 : 100k $\Omega$ , R2 : 0 to 500k $\Omega$
	R3 : 100k $\Omega$
	R4 : 300 $\Omega$
	R5 : 0 to 500k $\Omega$ , R6 : 50k $\Omega$

### Description

- Step up DC/DC converter : DC/DC1

The oscillator can operate when CSW is "H". When the CSW is "L" the EXT1 outputs GND.

The output voltage can be adjusted by R5 and R6 with FB1 of two volt.

- Inverting DC/DC converter : DC/DC2

The oscillator can operate when CSW is "H". When the CSW is "L" the EXT2 outputs VDD.

The output voltage can be adjusted by R1 and R2 with FB2 of zero volt.

- Voltage Detector

VDD pin can be monitored. This could be always operated with VDD.

The DOUT pin outputs "L" when low voltage is detected with Nch open-drain output.

## TYPICAL APPLICATION 3

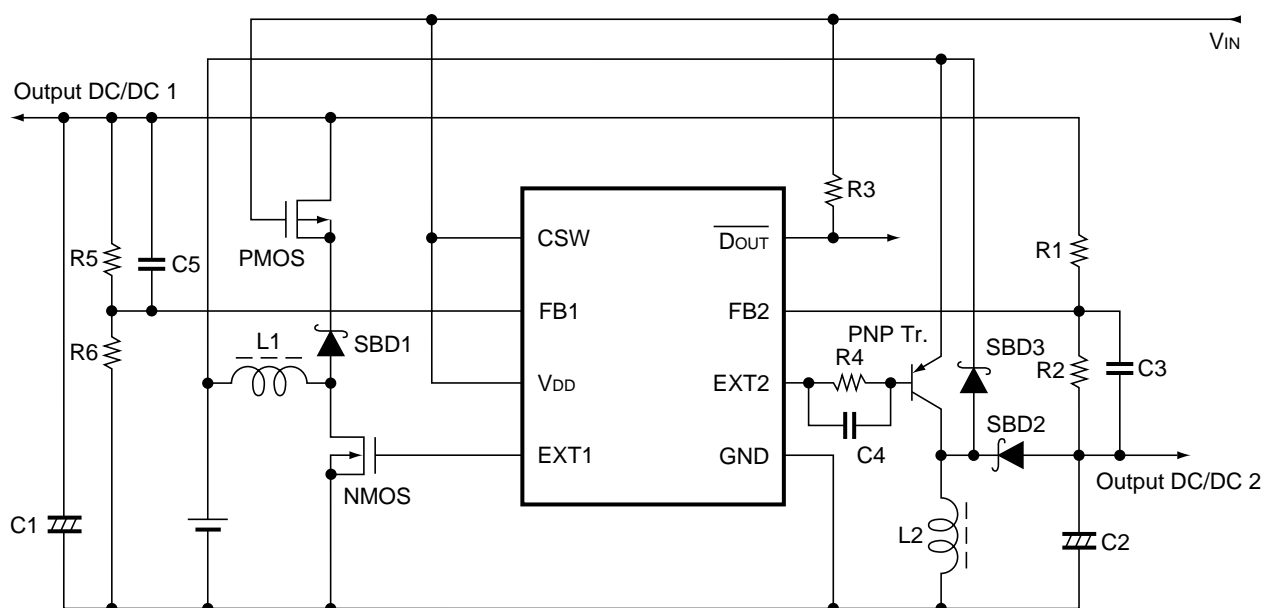

R1 : 820k $\Omega$ , R2 : 820k $\Omega$ , R3 : 100k $\Omega$ , R4 : 1k $\Omega$ , R5 : 750k $\Omega$  (Adjustable)  
 R6 : 100k $\Omega$   
 L1 : 68 $\mu$ H, L2 : 27 $\mu$ H  
 C1 : 22 $\mu$ F, C2 : 22 $\mu$ F, C3 : 1000pF, C4 : 2200pF, C5 : 1000pF  
 PMOS : 2SJ238, NMOS : 2SK1470, PNPT<sub>r</sub> : 2SB1120F

### Operation

The VDD voltage can be supplied from another source than battery output and a reference voltage for DC/DC2 is supplied by the output of DC/DC1.

The PMOS transistor can operate as a switch when the CSW is "L".

- Step up DC/DC converter : DC/DC1

The oscillator can operate when CSW is "H". When the CSW is "L" the EXT1 outputs GND.

The output voltage can be adjusted by R5 and R6 with FB1 of two volt.

- Inverting DC/DC converter : DC/DC2

The oscillator can operate when CSW is "H". When the CSW is "L" the EXT2 outputs VDD.

The output voltage can be adjusted by R1 and R2 with FB2 of zero volt.

- Voltage Detector

VDD pin can be monitored. This could be operated all the time by VDD.

The DOUT pin outputs "L" when low voltage is detected with Nch open-drain output.

# TYPICAL CHARACTERISTICS

1) Output Voltage vs. Output Current

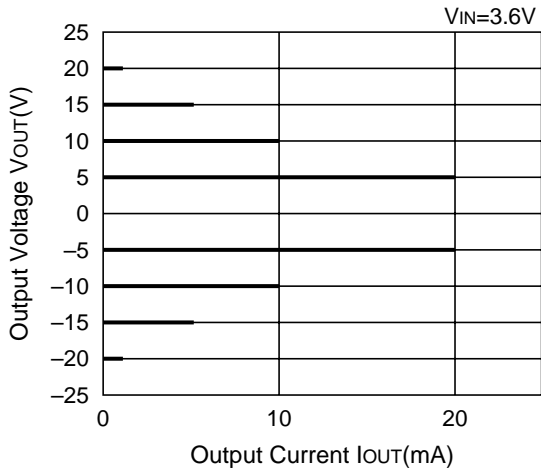

2) Efficiency vs. Output Current

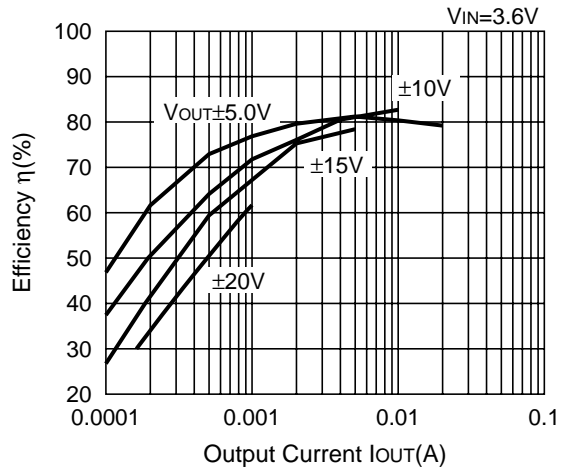

3) CSW Load Transient Response 1

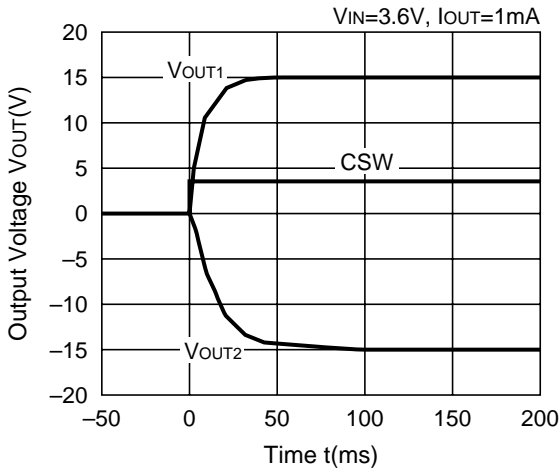

4) CSW Load Transient Response 2

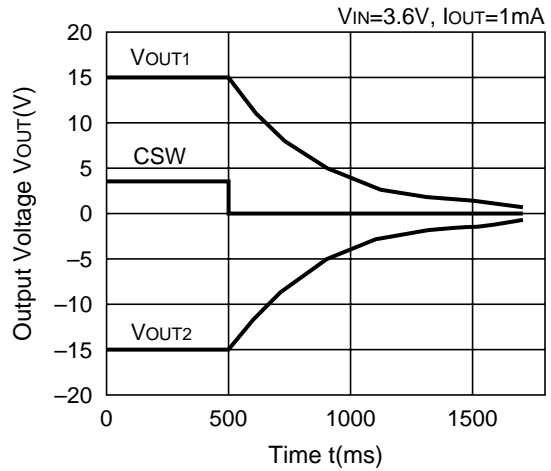

\* ) Please refer to Typical Application.

## SELECTION GUIDE

The output voltage, the type of DC/DC1 and the taping type for the ICs can be selected at the user's request.

The selection can be made by designating the part number as shown below:

RV5VH  $\overbrace{\text{XXX}}$   $\overbrace{\text{XX}}$  ← Part Number  
 ↑ ↑ ↑  
 a b c

Code	Contents
a	DC/DC1 type 1 : Internal Lx Driver Transister Type 2 : External EXT Driver Transister Type 3 : Variable Output Voltage Type
b	Serial (01, 02, 03) Number of Setting DC/DC1 Output Voltage and Setting VD Detect Voltage.
c	Designation of Taping type Ex. E1, E2 (refer to Taping Specifications, E2 type is prescribed as a standard.)

## APPLICATION HINTS

When using these ICs, be sure to take care of the following points.

- Set external components as close as possible to the IC and minimize the connection between the components and the IC. In particular, when an external component is connected to VOUT Pin, make minimum connection with the capacitor.
- Make sufficient grounding. A large current flows through GND Pin by switching. When the impedance of the GND connection is high, the potential within the IC is varied by switching current. This may result in unstable operation of the IC.
- Use capacitor with good high frequency characteristics such as tantalum capacitor, aluminium electrolytic capacitor and ceramic capacitor. We recommend the use of a capacitor with an allowable voltage which is at least three times the output set voltage. This is because there may be the case where a spike-shaped high voltage is generated by the inductor when Lx transistor is turned OFF.
- Take the utmost care when choosing an inductor. Namely, choose such an inductor that has sufficiently small d.c. resistance and large allowable current, and hardly reaches magnetic saturation. When the inductance value of the inductor is small, there may be the case where ILX exceeds the absolute maximum ratings at the maximum load. Use an inductor with an appropriate inductance. (See OUTPUT CURRENT and SELECTION OF PERIPHERAL COMPONENTS sections.)
- Use a diode of a Schottky type with high switching speed, and also take care of the rated current. (See OUTPUT CURRENT and SELECTION OF PERIPHERAL COMPONENTS sections.)

The performance of power source circuits using these ICs largely depends upon the peripheral components. Take the utmost care in the selection of the peripheral components. In particular, design the peripheral circuits in such a manner that the values such as voltage, current and power of each component, PCB patterns and the IC do not exceed their respective rated values.