

# Dual comparators

## BA10393 / BA10393F / BA10393N

The BA10393, BA10393F, and BA10393N are dual comparators with open-collector output which allows wired OR connections.

The operating power supply voltage ranges from 2 to 36V for a single power supply and  $\pm 1$  to  $\pm 18$ V for a dual power supply. The packages are as follows: DIP 8-pin (BA10393), SOP 8-pin (BA10393F), and SIP 8-pin (BA10393N).

### ●Features

- 1) Wide operating voltage range.  
(Single power supply: 2 to 36V, dual power supply:  $\pm 1$  to  $\pm 18$ V)
- 2) Low current dissipation. (0.4mA typ. at  $V_{CC} = 5$ V)
- 3) Low input offset voltage. (25nA typ. at  $V_{CC} = 5$ V) and low input offset voltage. (typically  $\pm 1.0$ mV at  $V_{CC} = 5$ V)
- 4) Wide common-mode input voltage. (0 to  $V_{CC} - 1.5$ V)
- 5) Open collector output.
- 6) Compatible with 393 comparators from other manufacturers.

### ●Block diagram

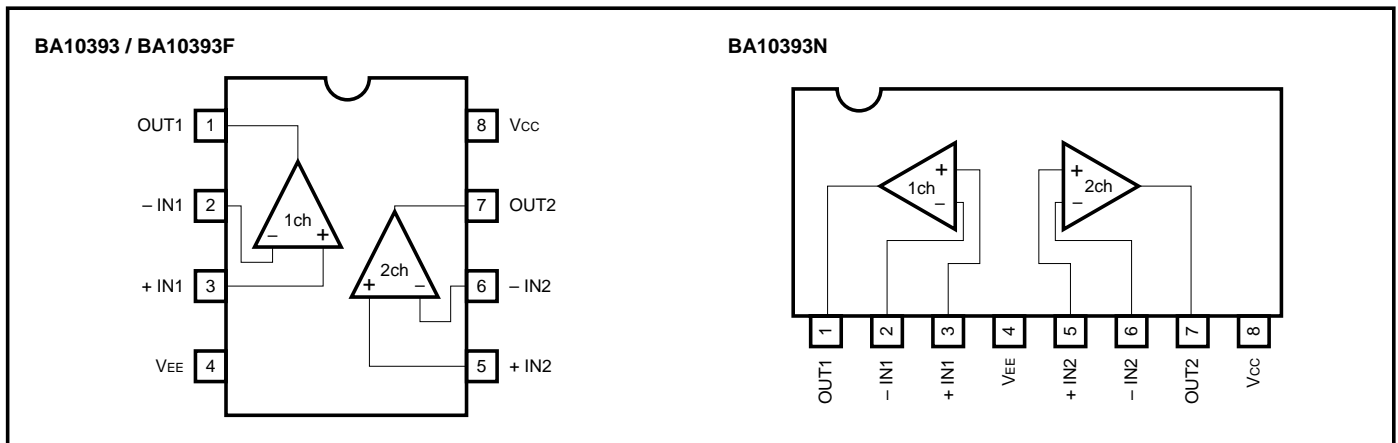

●Internal circuit configuration

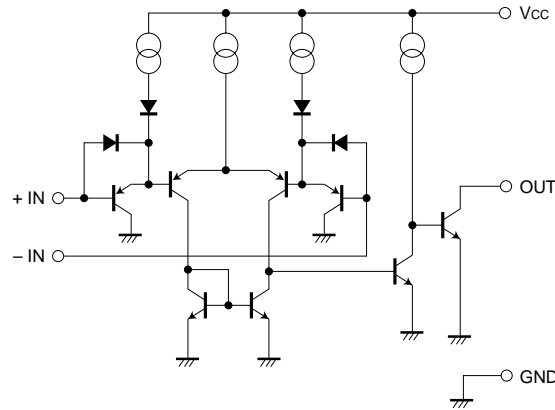

●Absolute maximum ratings (Ta = 25°C)

Parameter	Symbol	Limits			Unit
		BA10393	BA10393F	BA10393N	
Power supply voltage	V <sub>CC</sub>	36 (± 18)	36 (± 18)	36 (± 18)	V
Power dissipation	P <sub>d</sub>	800*	550*	900*	mW
Differential input voltage	V <sub>ID</sub>	± V <sub>CC</sub>	± V <sub>CC</sub>	± V <sub>CC</sub>	V
Common-mode input voltage	V <sub>I</sub>	- 0.3 ~ V <sub>CC</sub>	- 0.3 ~ V <sub>CC</sub>	- 0.3 ~ V <sub>CC</sub>	V
Operating temperature	T <sub>opr</sub>	- 40 ~ + 85	- 40 ~ + 85	- 40 ~ + 85	°C
Storage temperature	T <sub>stg</sub>	- 55 ~ + 125	- 55 ~ + 125	- 55 ~ + 125	°C

\* Refer to the Pd characteristics diagram.

The values for the BA10393F are those when it is mounted on a glass epoxy PCB (50mm × 50mm × 1.6mm).

●Electrical characteristics (unless otherwise noted, Ta = 25°C, V<sub>CC</sub> = + 5V)

Parameter	Symbol	Min.	Typ.	Max.	Unit	Conditions
Input offset voltage	V <sub>IO</sub>	—	± 1	± 5	mV	V <sub>O</sub> = 1.4V
Input offset current	I <sub>IO</sub>	—	± 5	± 50	nA	I <sub>IN+</sub> - I <sub>IN-</sub>  , V <sub>O</sub> = 1.4V
Input bias current	I <sub>B</sub>	—	25	250	nA	V <sub>O</sub> = 1.4V
Common-mode input voltage	V <sub>ICM</sub>	0	—	V <sub>CC</sub> - 1.5	V	
Voltage gain	A <sub>v</sub>	93	106	—	dB	R <sub>L</sub> = 15kΩ, V <sub>CC</sub> = 15V
Quiescent current	I <sub>Q</sub>	—	0.4	1	mA	R <sub>L</sub> = ∞, on All Comparators
Output sink current	I <sub>sink</sub>	6	16	—	mA	V <sub>IN-</sub> = + 1V, V <sub>IN+</sub> = 0V, V <sub>O</sub> = 1.5V
Output saturation voltage	V <sub>OL</sub>	—	250	400	mV	V <sub>IN-</sub> = + 1V, V <sub>IN+</sub> = 0V, I <sub>sink</sub> = 4mA
Output leakage current	I <sub>leak</sub>	—	0.1	—	nA	V <sub>IN+</sub> = + 1V, V <sub>IN-</sub> = 0V, V <sub>O</sub> = 5V
Response time	t <sub>r</sub>	—	1.3	—	μs	R <sub>L</sub> = 5.1kΩ, V <sub>RL</sub> = 5V

●Electrical characteristic curves

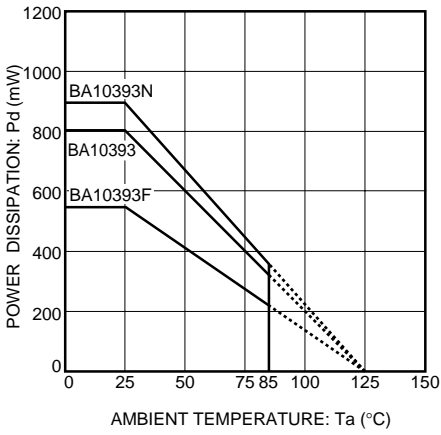

Fig. 1 Power dissipation vs. ambient temperature

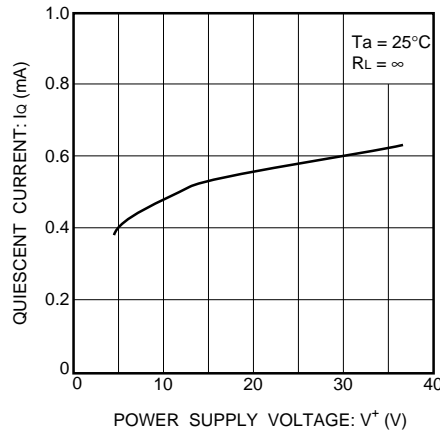

Fig. 2 Quiescent current vs. power supply voltage

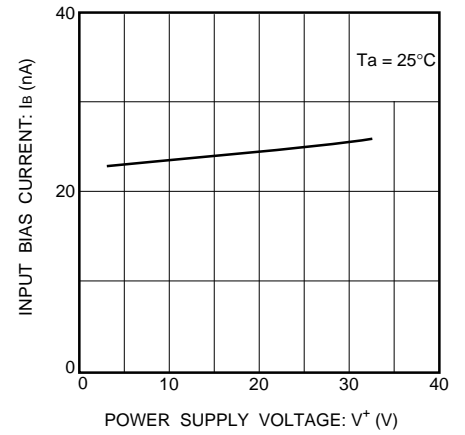

Fig. 3 Input bias current vs. power supply voltage

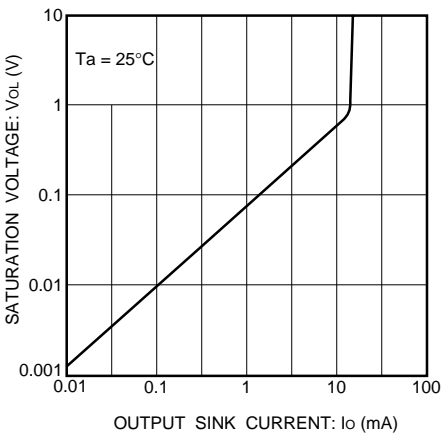

Fig. 4 Output saturation voltage vs. output current

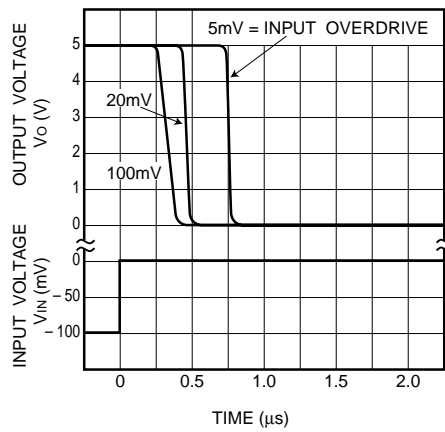

Fig. 5 Propagation characteristics ( I )

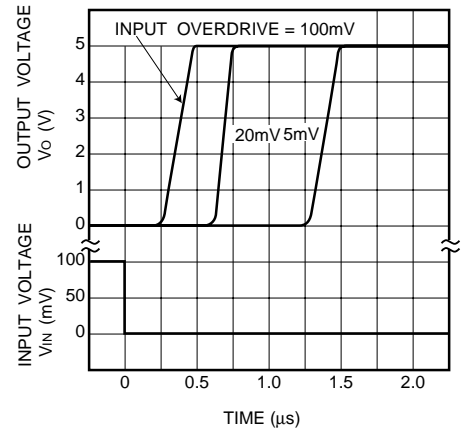

Fig. 6 Propagation characteristics ( II )

●Operation notes

(1) Handling unused circuits

If a circuit is not in use, we recommend connecting it as shown in Figure 7, so that its input is connected to the potential within the in-phase input voltage range ( $V_{ICM}$ ) and the output is left open.

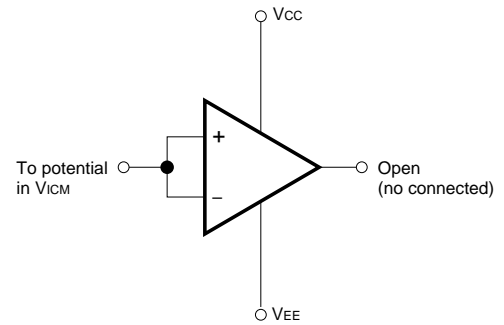

Fig. 7 Example of unused circuit connection

●External dimensions (Units: mm)

