

4-channel BTL driver for CD players and CD-ROMs

BA5916FP-Y

The BA5916FP-Y contains a 4-channel BTL driver for CD player and CD-ROM motors and actuators and a multi-purpose operational amplifier. Perfect for compact applications with the use of the HSOP 25-pin package.

●Applications

CD players, CD-ROM

●Features

- 1) 4-channel BTL driver.
- 2) Perfect for compact applications with the use of the HSOP 25-pin power package.
- 3) Wide dynamic range (3.6V (Typ.) when $V_{CC} = 5V$ and $R_L = 8\Omega$).
- 4) Internal thermal shutdown circuit.
- 5) Gain is adjustable with externally connected resistor.
- 6) Internal multi-purpose operational amplifier.
- 7) Standby pin allows IC to enter power saving mode.

●Absolute maximum ratings ($T_a = 25^\circ\text{C}$)

Parameter	Symbol	Limits	Unit
Power supply voltage	V_{CC}	7	V
Power dissipation	P_d	1.45 *	W
Operating temperature	T_{opr}	$-35 \sim +85$	$^\circ\text{C}$
Storage temperature	T_{stg}	$-55 \sim +150$	$^\circ\text{C}$

* When mounted on a 70mm × 70mm × 1.5mm glass epoxy board with copper foil coverage of less than 3%.

Reduced by 11.6mW for each increase in T_a of 1 $^\circ\text{C}$ over 25 $^\circ\text{C}$.

●Recommended operating conditions ($T_a = 25^\circ\text{C}$)

Parameter	Symbol	Min.	Typ.	Max.	Unit
Power supply voltage	V_{CC}	4.3	5	6.6	V

●Block diagram

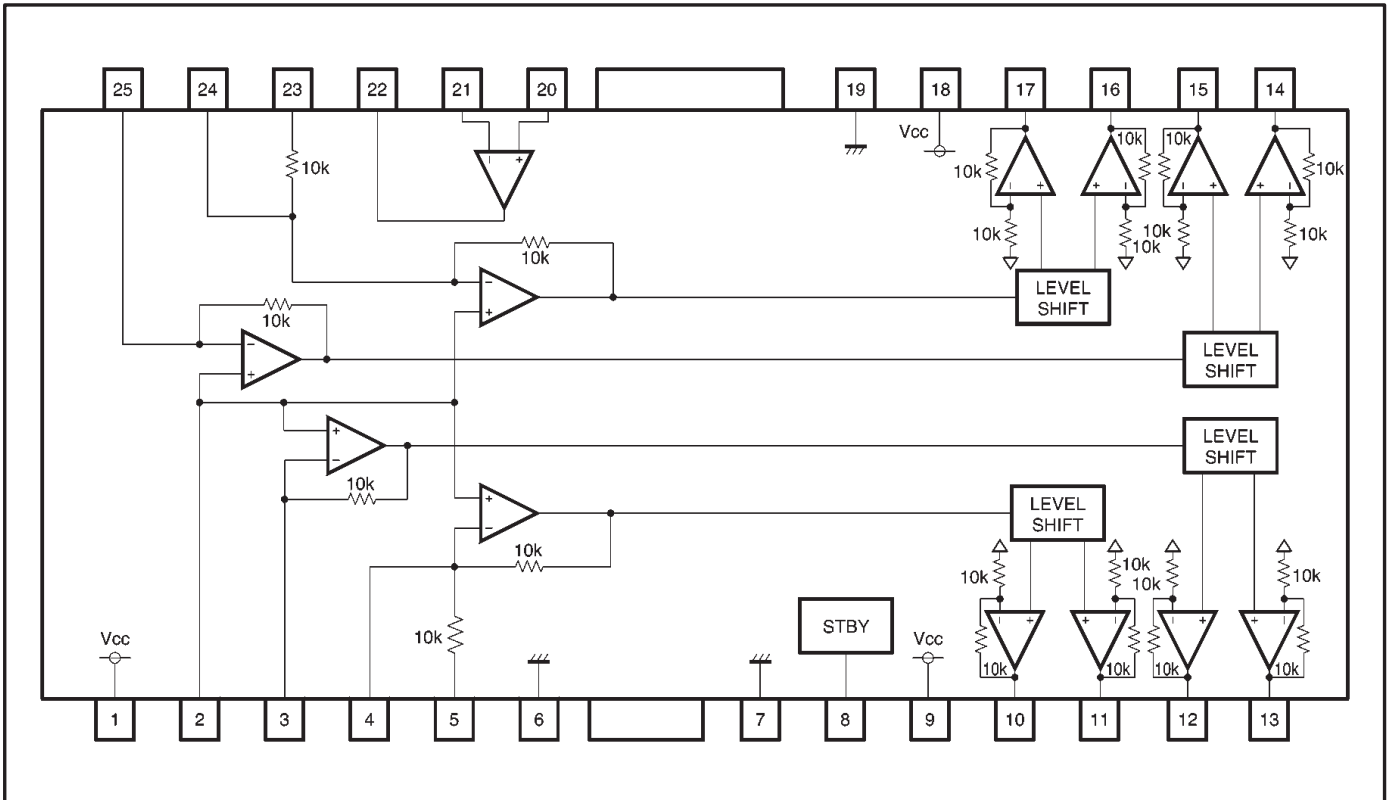

●Pin descriptions

Pin No.	Pin name	Function	Pin No.	Pin name	Function
1	Vcc	Vcc	14	VO4 (+)	Driver channel 4 positive output
2	BIAS IN	Bias amplifier input	15	VO4 (-)	Driver channel 4 negative output
3	VIN1	Driver channel 1 input	16	VO3 (+)	Driver channel 3 positive output
4	VIN2'	Input for driver channel 2 gain adjustment	17	VO3 (-)	Driver channel 3 negative output
5	VIN2	Driver channel 2 input	18	Vcc	Vcc
6	GND	GND	19	GND	GND
7	GND	GND	20	OP IN (+)	Op-amp positive input
8	STBY	Standby control	21	OP IN (-)	Op-amp negative input
9	Vcc	Vcc	22	OP OUT	Op-amp output
10	VO2 (-)	Driver channel 2 negative output	23	VIN3	Driver channel 3 input
11	VO2 (+)	Driver channel 2 positive output	24	VIN3'	Input for driver channel 3 gain adjustment
12	VO1 (-)	Driver channel 1 negative output	25	VIN4	Driver channel 4 input
13	VO2 (+)	Driver channel 1 positive output			

Note: Positive output and negative output are the polarities with respect to the input.
 If the input pin is high, the negative output pin is low and the positive output pin is high.

● Input / output circuits

Driver input

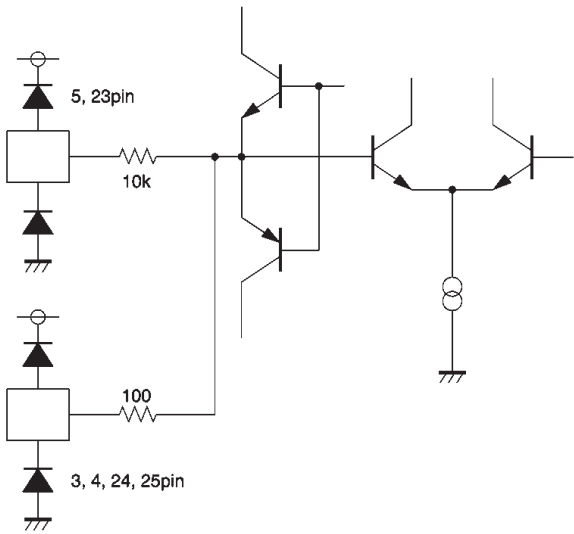

Driver output

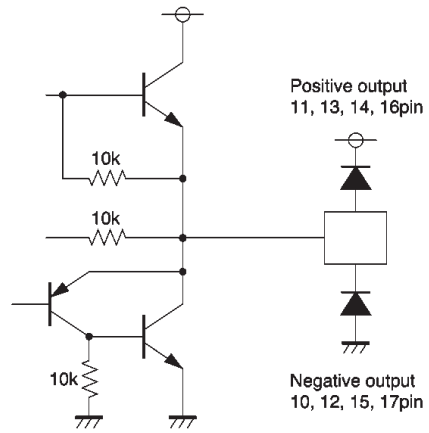

Bias

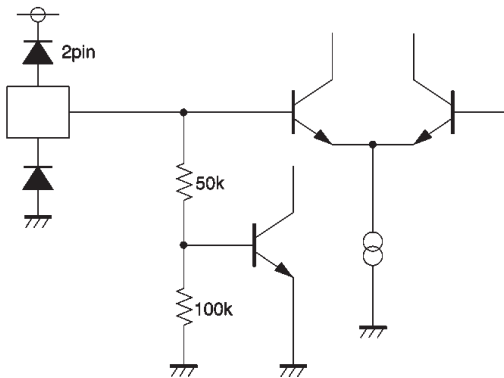

Standby

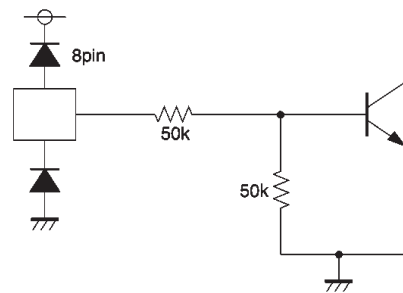

Op-amp input

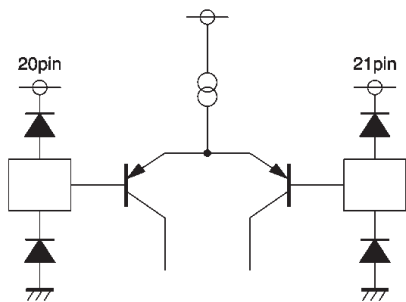

Op-amp output

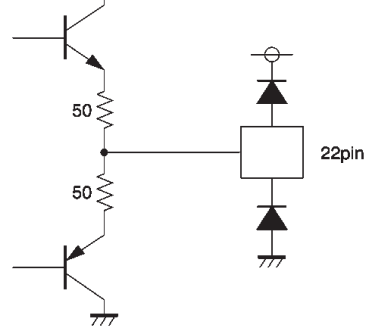

●Electrical characteristics (unless otherwise noted, $T_a = 25^\circ\text{C}$, $V_{CC} = 5\text{V}$, $\text{BIAS} = 2.5\text{V}$, $R_{IN} = 10\text{k}\Omega$, $R_L = 8\Omega$)

Parameter	Symbol	Min.	Typ.	Max.	Unit	Conditions
Circuit current during standby	I_{ST}	—	—	200	μA	—
Circuit current	I_{CC}	—	13	20	mA	No load
Output offset voltage	V_{OO}	−40	—	40	mV	—
Maximum output amplitude	V_{OM}	3.1	3.6	—	V	—
Closed-loop voltage gain 1	G_{VC1}	10.4	11.8	13.2	dB	$V_{IN}=0.1\text{V}_{rms}$, 1kHz (ch2, 3)
Closed-loop voltage gain 2	G_{VC2}	9.8	11.8	13.8	dB	$V_{IN}=0.1\text{V}_{rms}$, 1kHz (ch1, 4)
Standby voltage	V_{STBY}	—	—	0.5	V	—
Standby release voltage	V_{STOFF}	2.0	—	—	V	—
〈Operational amplifier〉						
Offset voltage	V_{OFOP}	−6	0	6	mV	—
Input bias current	V_{BOP}	—	—	300	nA	—
Output high level voltage	V_{OHOP}	3.9	4.35	—	V	—
Output low level voltage	V_{OLOP}	—	0.75	1.1	V	—
Output drive current sink	I_{SI}	10	30	—	mA	50Ω at V_{CC}
Output drive current source	I_{SO}	10	25	—	mA	50Ω at GND
Slew rate	SROP	—	1	—	$\text{V} / \mu\text{s}$	100kHz rectangular wave, $2V_{P-P}$ output

◎Not designed for radiation resistance.

● Measurement circuits

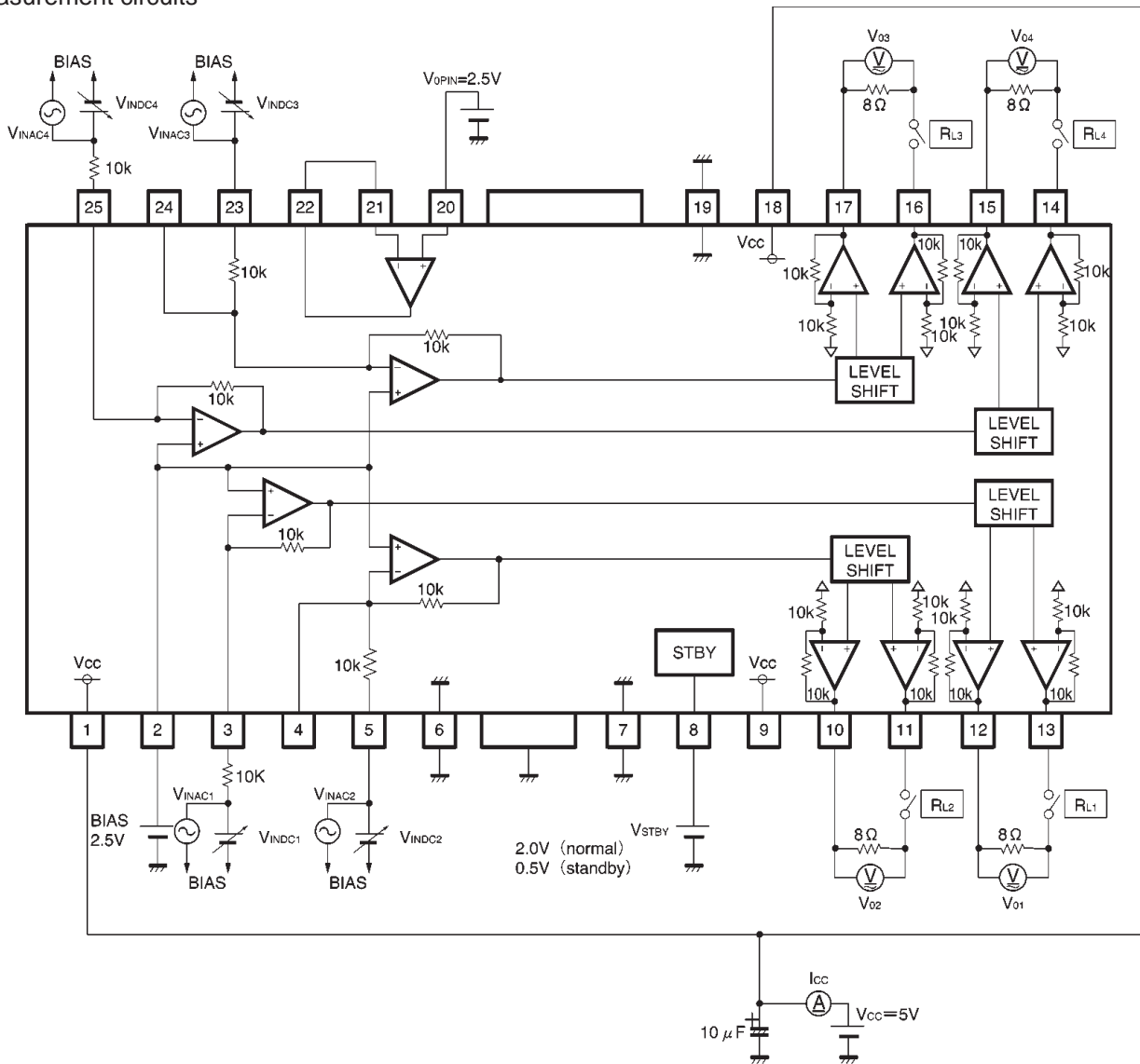

Fig.1 Driver block measurement circuit diagram

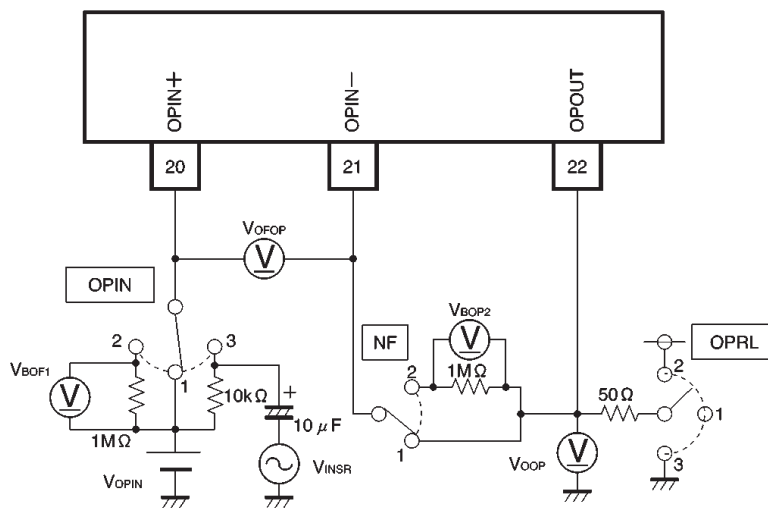

Fig.2 Operational amplifier measurement circuit diagram

●Application example

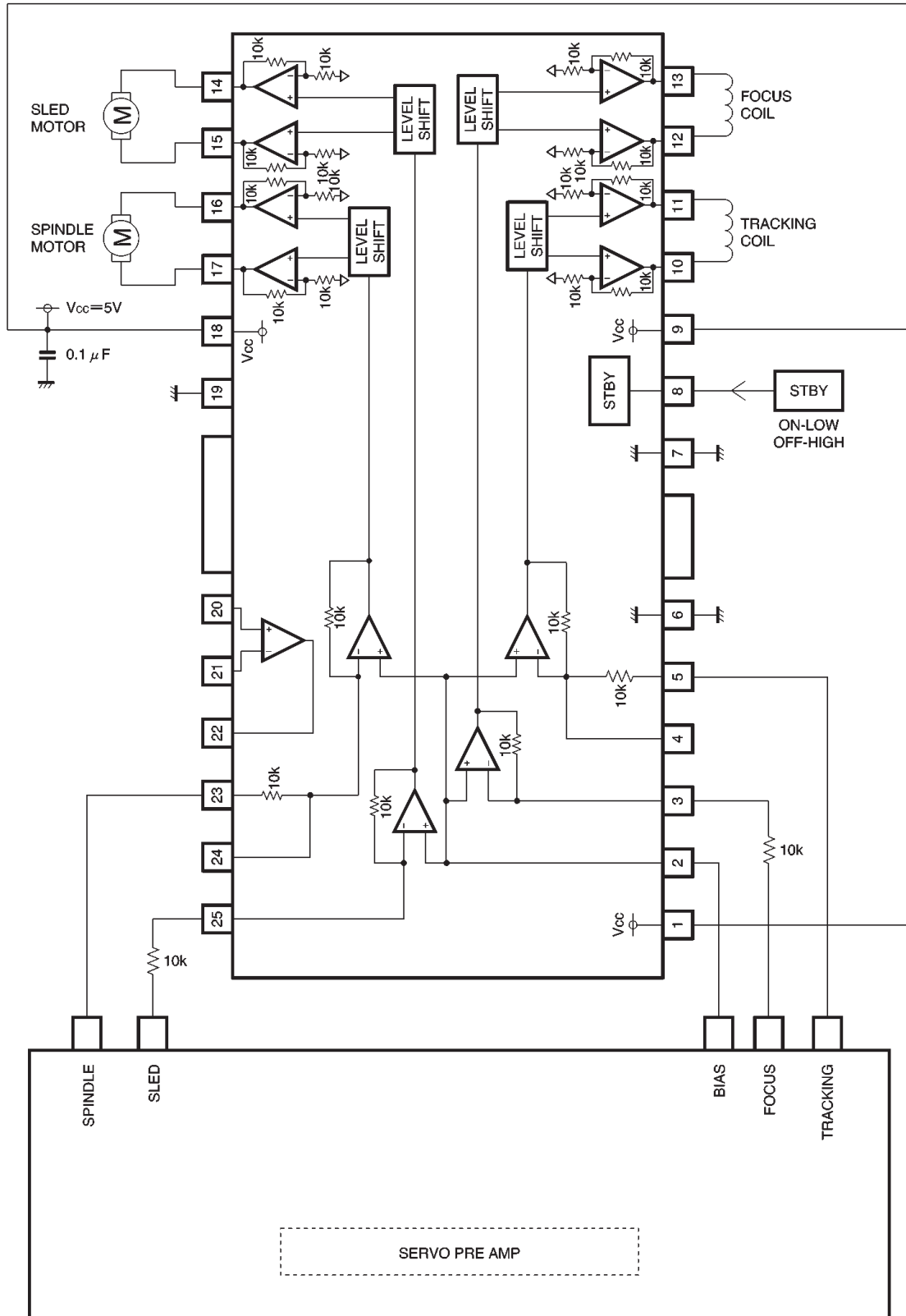

Fig.3

● Operation notes

(1) The BA5916FP-Y contains a thermal shutdown circuit.

When the chip temperature reaches 175°C (Typ.), the output current is muted. If the chip temperature then drops below 150°C (Typ.), then the mute is released.

(2) By having the standby pin (pin 8) voltage open or lowered to 0.5V or below, the drivers turn off and the IC enters the power saving mode.

For normal operation, have the standby pin (pin 8) voltage pulled up to 2.0V or greater.

(3) If the voltage of the bias pin (pin 2) drops below 1.0V (Typ.), outputs are muted. For normal conditions, have the voltage above 1.4V.

(4) If the voltage of the thermal shutdown or bias pin drops, the mute is activated; however, in these situations, only the drivers are muted.

Also, the output pin voltage becomes the internal bias voltage (approx. $V_{CC} - VF/2$).

(5) Connect a bypass capacitor (approx. 0.1μF) between the bases of the power supply pins of this IC.

(6) Even though the radiation fins are connected to ground within the package, be sure to also connect them to a ground externally as well.

● Electrical characteristic curves

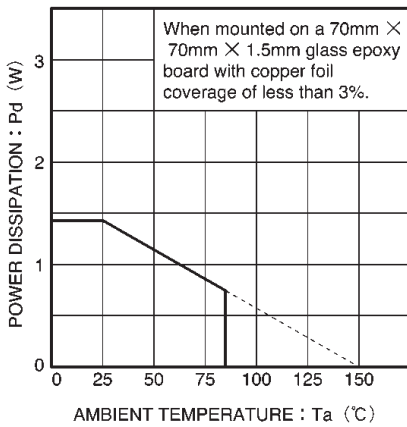

Fig.4 Thermal derating curve

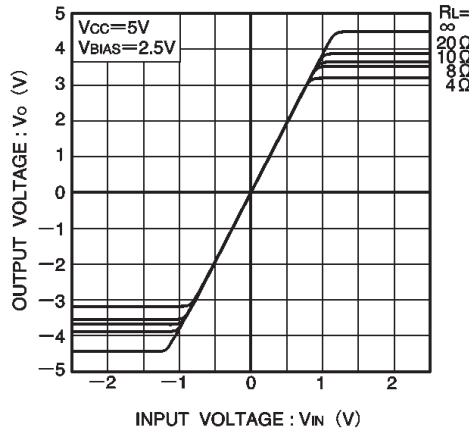

Fig.5 Driver I/O characteristics

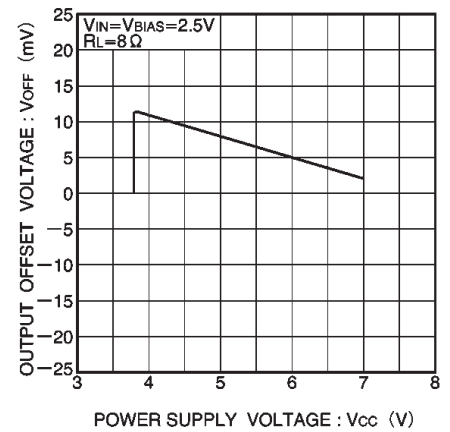

Fig.6 Power supply voltage vs. output offset voltage

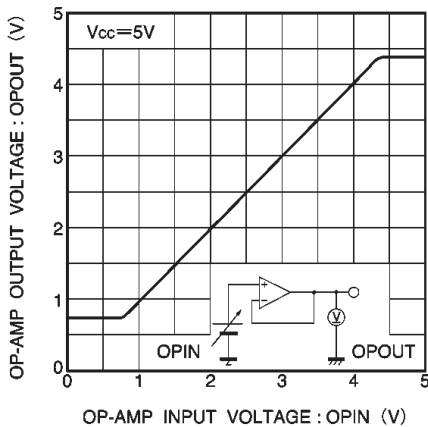

Fig.7 Op-amp I/O characteristics

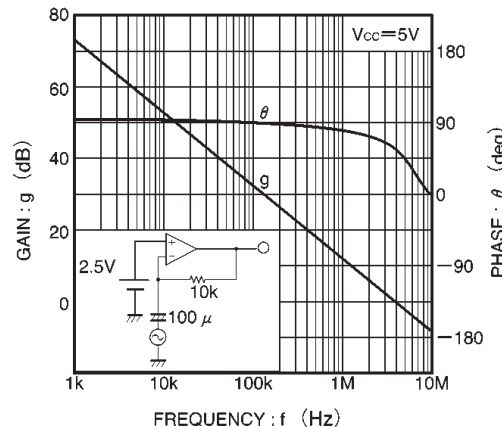

Fig.8 Op-amp open loop characteristics

● External dimensions (Units: mm)

