

FDD spindle motor driver

BA6486FS

The BA6486FS is a one-chip IC designed for driving 12V FDD spindle motors. This high-performance IC employs a 3-phase, full-wave soft switching drive system, and contains a digital servo, an index amplifier, and a power save circuit. The compactly packaged IC reduces the number of external components required.

●Applications

Floppy disk drivers

●Features

- | | |
|--|------------------------------|
| 1) 12V supply voltage. | 5) Hall power supply switch. |
| 2) 3-phase, full-wave soft switching drive system. | 6) Motor speed changeable. |
| 3) Digital servo circuit. | 7) Index amplifier. |
| 4) Power save circuit. | |

●Absolute maximum ratings (Ta = 25°C)

Parameter	Symbol	Limits	Unit
Applied voltage	Vcc	15.0	V
Power dissipation	Pd	1000*	mW
Operating temperature	Topr	-25~+75	°C
Storage temperature	Tstg	-55~+150	°C
Allowable output current	IoMax.	1000	mA

* Reduced by 8.0mW for each increase in Ta of 1°C over 25°C.

* Mounted on a glass epoxy PCB (90 X 50 X 1.6 mm).

●Recommended operating conditions (Ta = 25°C)

Parameter	Symbol	Limits	Unit
Power Supply voltage	Vcc	9.0~13.2	V

● Block diagram

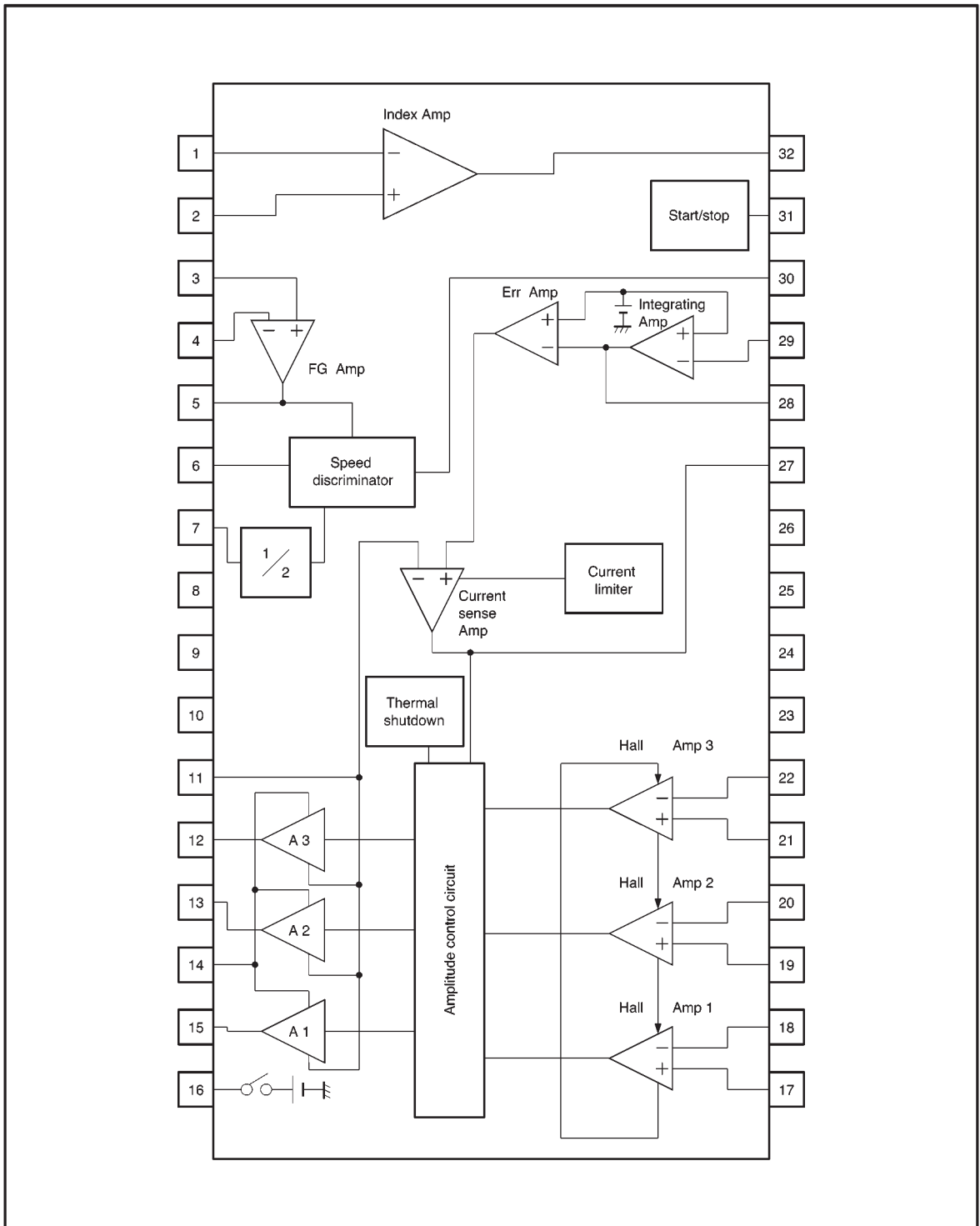

● Pin descriptions

Pin No.	Pin name	Function
1	IDX ⁻	Index amplifier input (-)
2	IDX ⁺	Index amplifier input (+)
3	FGin ⁺	FG amplifier input (+)
4	FGin ⁻	FG amplifier input (-)
5	FGout	FG amplifier output
6	SC	Speed control
7	OSC	Oscillator input
8	GND	GND
9	GND	GND
10	V _{CC}	Signal power supply
11	R _{NF}	Driver power supply (current detection pin)
12	A ₃	Motor output 3
13	A ₂	Motor output 2
14	P - GND	Driver ground pin
15	A ₁	Motor output 1
16	H - GND	Hall bias switch (ground)

Pin No.	Pin name	Function
17	H ₁ ⁺	Hall input amplifier 1 input (+)
18	H ₁ ⁻	Hall input amplifier 1 input (-)
19	H ₂ ⁺	Hall input amplifier 2 input (+)
20	H ₂ ⁻	Hall input amplifier 2 input (-)
21	H ₃ ⁺	Hall input amplifier 3 input (+)
22	H ₃ ⁻	Hall input amplifier 3 input (-)
23	GND	GND
24	GND	GND
25	GND	GND
26	S - GND	Signal ground pin
27	C _{NF}	Current sensing amplifier output (for phase compensation)
28	Err	Error amplifier input; integrating amplifier output
29	INT	Integrating amplifier inverter input (-)
30	SDO	Speed discriminator output
31	ST / SP	Start/stop pin
32	IDXO	Index amplifier output

● Electrical characteristics (unless otherwise noted, T_a = 25°C, V_{CC} = 12V)

Parameter	Symbol	Min.	Typ.	Max.	Unit	Conditions
Supply current 1	I _{cc1}	12	18	31	mA	Oprating state
Supply current 2	I _{cc2}	—	—	3	μA	Standby state
Hall in-phase input voltage	V _{HB}	1.5	—	10.5	V	
Hall amplifier input sensitivity	V _{Hin}	40	—	—	mV _{P-P}	Differential input
Output saturation voltage 1	V _{sat1}	—	1.2	1.4	V	I _{out} = 350 mA (total of upper and lower values)
Output saturation voltage 2	V _{sat2}	—	1.5	2.0	V	I _{out} = 700 mA (total of upper and lower values)
Speed discriminator output voltage, HIGH	V _{DH}	11.7	11.9	—	V	When output current is 500 μA
Speed discriminator output voltage, LOW	V _{DL}	—	0.1	0.25	V	When input current is 500 μA
Integrated amplifier output high level voltage	V _{EinH}	6.0	6.2	6.4	V	29pin=5.5V
Integrated amplifier output low level voltage	V _{EinL}	4.7	4.9	5.1	V	29pin=6.5V
FG amplifier gain	G _{FG}	39	42	45	dB	f=300Hz
Speed discriminator minimum input	V _{FGmi}	3.0	—	—	mV _{P-P}	FG amplifier input conversion
Speed discriminator noise margin	V _{FGnm}	—	—	0.5	mV _{P-P}	FG amplifier input conversion
Error amplifier reference voltage	V _{Err}	6.05	6.2	6.35	V	
Control input gain	G _{Err}	-14.5	-11	-8.5	dB	V28 pin versus V11 pin, R _{NF} =0.5Ω
Current limiter voltage	V _{cl}	207	230	253	mV	Voltage between V _{CC} and V11 pin R _{NF} =0.5Ω

Parameter	Symbol	Min.	Typ.	Max.	Unit	Conditions
External clock frequency	f_{CK}	—	1000	1100	kHz	
External clock input threshold voltage	V_{CK}	1.0	—	2.0	V	
External clock input inflow current	I_{CKH}	—	—	10	μA	
External clock input outflow current	I_{CKL}	—	2	10	μA	
Start/stop voltage, HIGH	V_{SSH}	3.0	—	12.0	V	Operating state
Start/stop voltage, LOW	V_{SSL}	0.0	—	0.5	V	Standby state
Revolving speed switch voltage, HIGH	V_{SCH}	2.0	—	12.0	V	Synchronized at $f_{FG} = 300$ Hz
Revolving speed switch voltage, LOW	V_{SCL}	0.0	—	1.0	V	Synchronized at $f_{FG} = 360$ Hz
Hall bias saturation voltage	V_{HG}	—	1.5	1.8	V	When input current is 10 mA
Index in-phase input voltage range	V_{BID}	1.5	—	10.5	V	
Index input offset voltage	V_{osID}	−5	0	+5	mV	
Index input hysteresis 1	V_{hyID1}	8	18	28	mV	
Index input hysteresis 2	V_{hyID2}	−41	−23	−12	mV	
Index I/O resistance	R_{oID}	17	25	33	k Ω	
Index output low level voltage	V_{oIID}	—	0.2	0.4	V	When input current is 500 μA

© Not designed for radiation resistance

● Circuit operation

(1) Motor drive circuit

The motor driver is based on a 3-phase, full-wave soft switching, current drive system in which the position of rotor is sensed by Hall elements. The total drive current of motor is sensed by a small resistor (R_{NF}) and regulated through a voltage comparison. The IC consists of Hall amplifiers, an amplitude control circuit, a driver, an error amplifier, and current feedback amplifier (Fig. 1).

The waveforms of different steps along the signal path from the Hall elements to the motor driver output are shown in Fig. 2. The Hall amplifiers receive the Hall elements voltage signals as differential signals. Next, by deducting the voltage signal of Hall elements 2 from the voltage signal of Hall elements 1, current signal H1, which has a phase 30 degrees ahead of Hall element 1, is created. Current signals H2 and H3 are created likewise. The amplitude control circuit then amplifies the H1, H2, and H3 signal according to the current feedback amplifier signal. Then, drive current signals are produced at A1, A2, and A3 by applying a constant magnification factor. Because a soft switching system is employed, the drive current has low noise and a low total current ripple. The total drive current is controlled by the error amplifier input voltage. The error amplifier has a voltage gain of about −11dB (a factor of 0.28). The current feedback am

plifier regulates the total drive current, so that the error amplifier output voltage (V_1) is equal to the V_{RNF} voltage, which has been voltage-converted from the total drive current through the R_{NF} pin. If V_1 exceeds the current limiter voltage (V_{cl}), the constant voltage V_{cl} takes precedence, and a current limit is applied at the level of V_{cl}/R_{NF} . The current feedback amplifier tends to oscillate because it receives all the feedback with a gain of 0dB. To prevent this oscillation, connect an external capacitor to the C_{NF} pin for phase compensation and for reducing the high frequency gain.

(2) Speed control circuit

The speed control circuit is a non-adjustable digital servo system that uses a frequency locked loop (FLL). The circuit consists of an 1/2 frequency divider, an FG amplifier, and a speed discriminator (Fig. 14).

An internal reference is generated from an external clock signal input. The 1/2 frequency divider reduces the frequency of the OSC signal. The FG amplifier amplifies the minute voltage generated by the motor FG pattern and produces a rectangular-shaped speed signal. The FG amplifier gain ($G_{FG} = 42$ dB, typical) is determined by the internal resistance ratio.

For noise filtering, a high-pass filter is given by C3 and a resistor of 1.6kΩ (typical), and a low-pass filter is given by C4 and a resistor of 200kΩ (typical). The cutoff frequencies of high-pass and low-pass filters (f_H and f_L , respectively) are given by:

$$f_H = \frac{1}{2\pi \times 1.6\text{k}\Omega \times C3} \quad f_L = \frac{1}{2\pi \times 200\text{k}\Omega \times C4}$$

The C3 and C4 capacitances should be set so as to satisfy the following relationship:

$$f_H < f_{FG} < f_L$$

where f_{FG} is the FG frequency. Note that the FG amplifier inputs have a hysteresis.

The speed discriminator divides the reference clock and compares with the reference frequency, and then outputs an error pulse according to the frequency difference. The motor rotational speed N is given in the following formula.

$$N = 60 \cdot \frac{f_{osc}}{n} \cdot \frac{1}{z} \quad (1)$$

f_{osc} is the reference clock frequency,
 n is (speed discriminator count) $\times 2$,
 z is the FG tooth number.

The discriminator count depends on the speed control pin voltage.

The integrator flattens out the error pulse of the speed discriminator and creates a control signal for the motor drive circuit (Fig. 15).

(3) Index amplifier

The index amplifier is a hysteresis amplifier with a typical hysteresis width of +18mV and -22mV. The input pin is not biased internally.

(4) Other circuits

- Start/stop circuit

The start/stop circuit puts the IC to the operating state when the control pin is LOW, and to the standby state (circuit current is nearly zero) when the control pin is HIGH. The Hall device bias switch, which is linked to the start/stop circuit, is turned off during the standby state, so that the Hall device current is shut down.

- Thermal shutdown circuit

This circuit shuts down the IC currents when the chip junction temperature is increased to about 175°C (typical). The thermal shutdown circuit is deactivated when the temperature drops to about 155°C (typical).

Speed control pin	Count
H	1666
L	1388

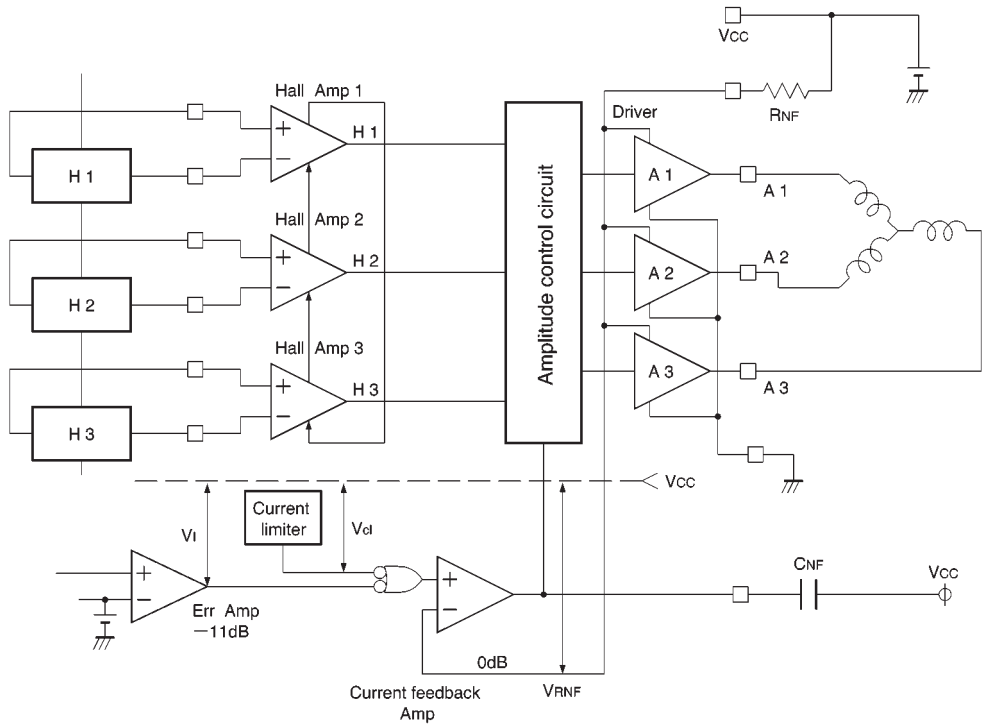

Fig.1 Motor drive circuit

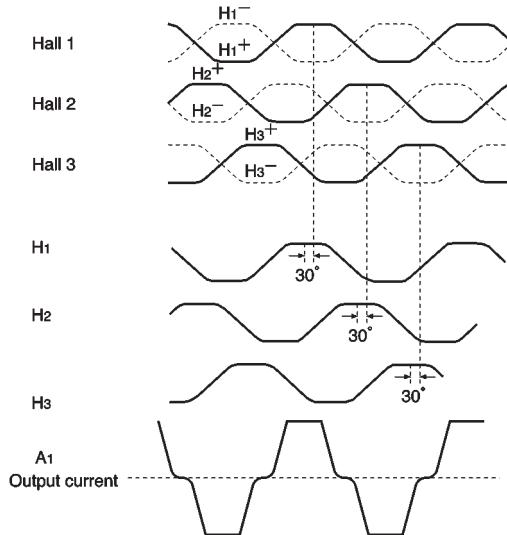

Fig.2 I/O waveforms

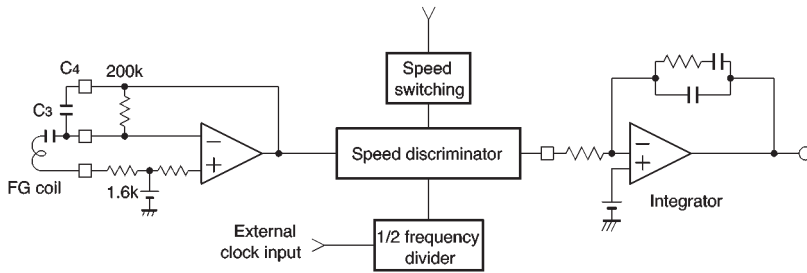

Fig.3 Speed control circuit

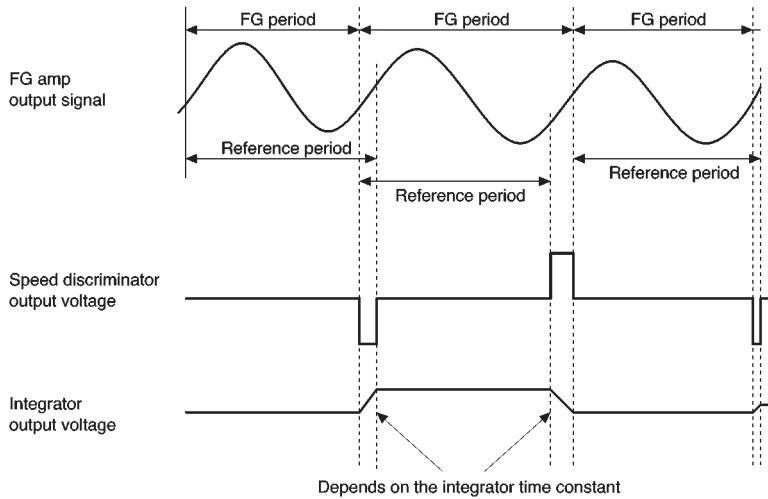

Fig.4 Control signal waveforms

● Operation notes

(1) Thermal shutdown circuit

This circuit shuts down all the IC currents when the chip junction temperature is increased to about 175°C (typical). The thermal shutdown circuit is deactivated when the temperature drops to about 155°C (typical).

(2) Hall elements connection

Hall elements can be connected in either series or parallel. When connecting in series, care must be taken not to allow the Hall output to exceed the Hall common-mode input range.

(3) Hall input level

Switching noise may occur if the Hall input voltage (pins 17~22) is too high. Differential inputs of about 100mV_{p-p} are recommended.

(4) Driver ground pin (14 pin)

Pin 14, which is the motor current ground pin, is not connected to the signal ground pin (26 pin). Design a proper conductor pattern in consideration of the motor current that flows through pin 14.

(5) External clock

Make sure that the pin 7 voltage is always less than V_{CC} and more than the ground voltage.

● Input/output circuits

(1) Index input (1, 2 pin)

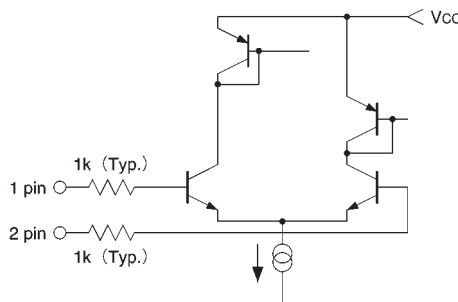

(2) FG amplifier (3~5 pin)

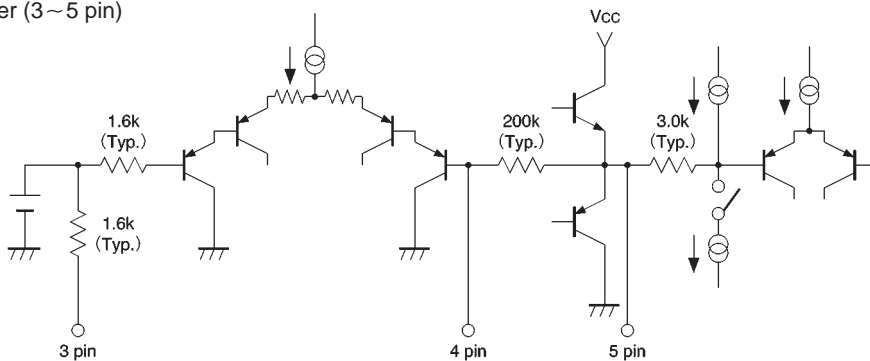

(3) Speed control (6 pin)

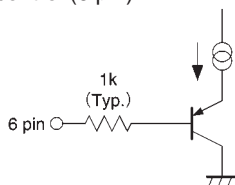

(4) External clock input (7 pin)

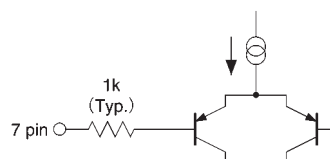

(5) Motor output (11 ~ 15 pin)

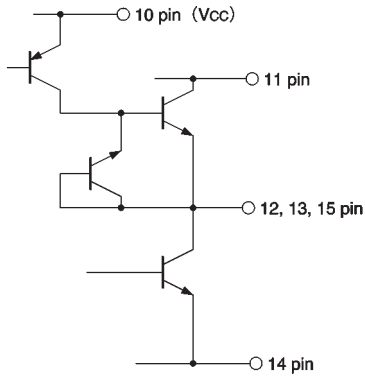

(6) Hall bias (16 pin)

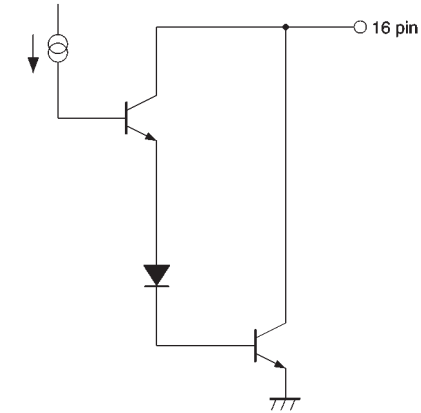

(7) Hall input (17 ~ 22 pin)

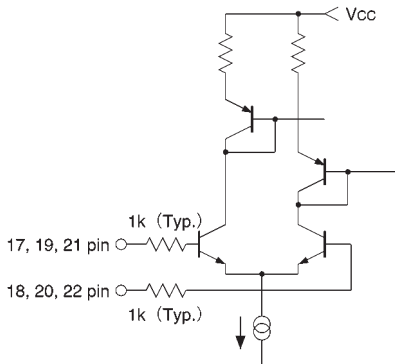

(8) Integrating amplifier (28, 29 pin)

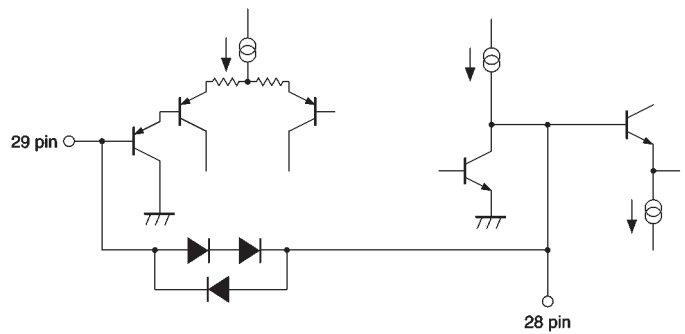

(9) Speed discriminator output (30 pin)

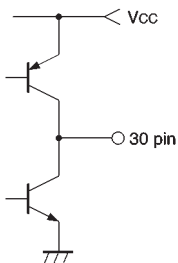

(10) Start/stop (31 pin)

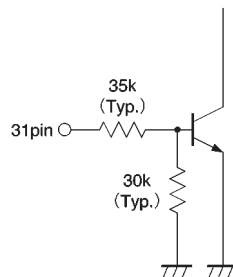

(11) Index output (32 pin)

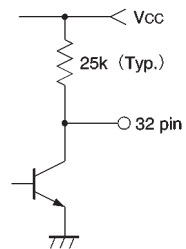

●Application example

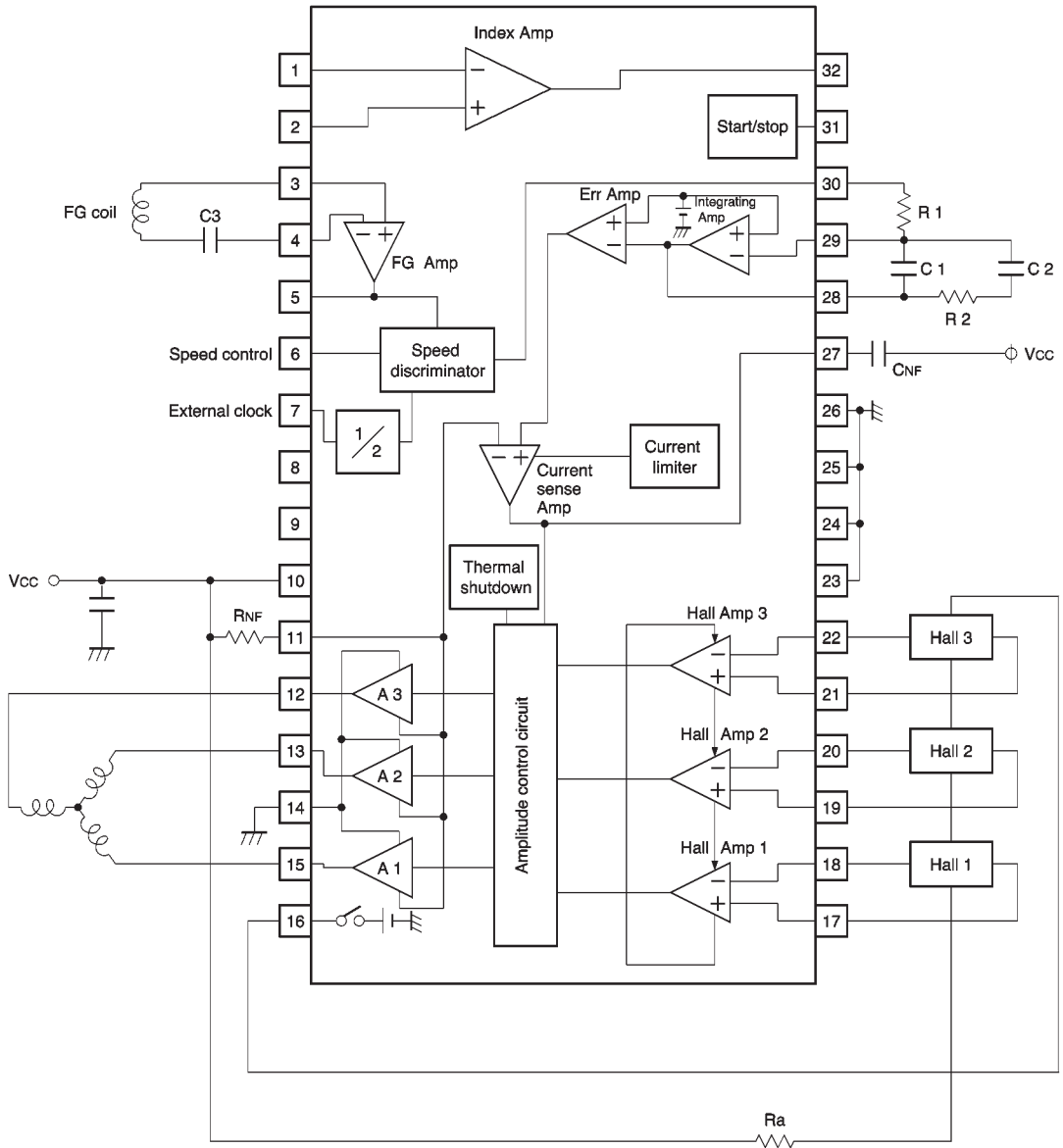

Fig.5

●Electrical characteristic curves

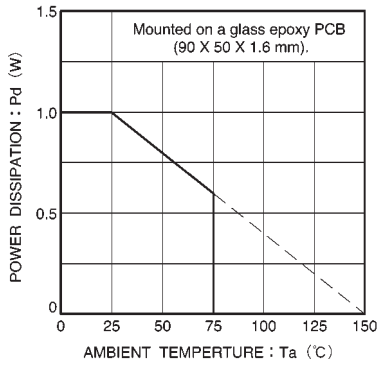

Fig.6 Power dissipation curve

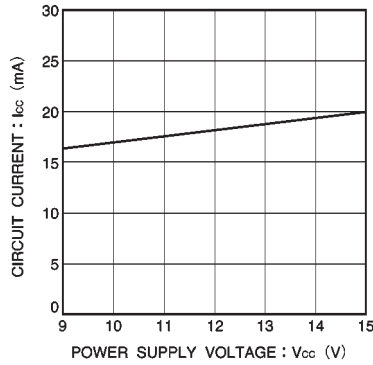

Fig.7 Circuit current vs. power supply voltage

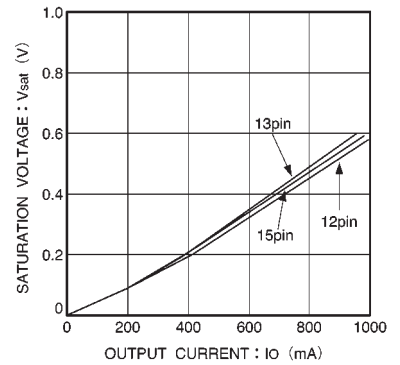

Fig.8 Low-side output saturation voltage vs. output current

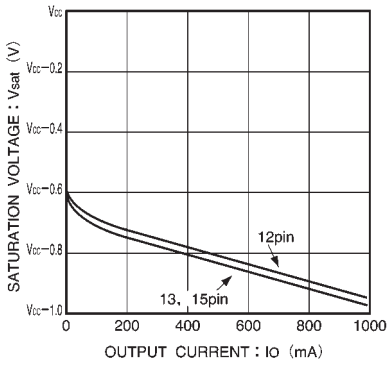

Fig.9 High-side output saturation voltage vs. output current

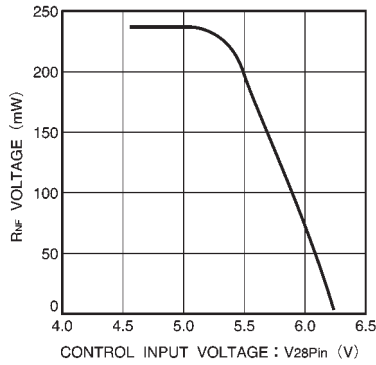

Fig.10 R_{NF} voltage vs. control input voltage

●External dimensions (Units: mm)

