

Clock generator for PD

BU2190F

The BU2190F is a clock generator IC for PD system drives, and uses a single crystal resonator to generate the three clock signals needed for PD system drives.

●Applications

PD system

●Features

- 1) Clock signals of three different frequencies can be generated with a single attached crystal resonator.
- 2) Internal PLL loop filter, eliminating the need for an attached loop.
- 3) Single 5.0V power supply.
- 4) SOP 8-pin package.

●Block diagram

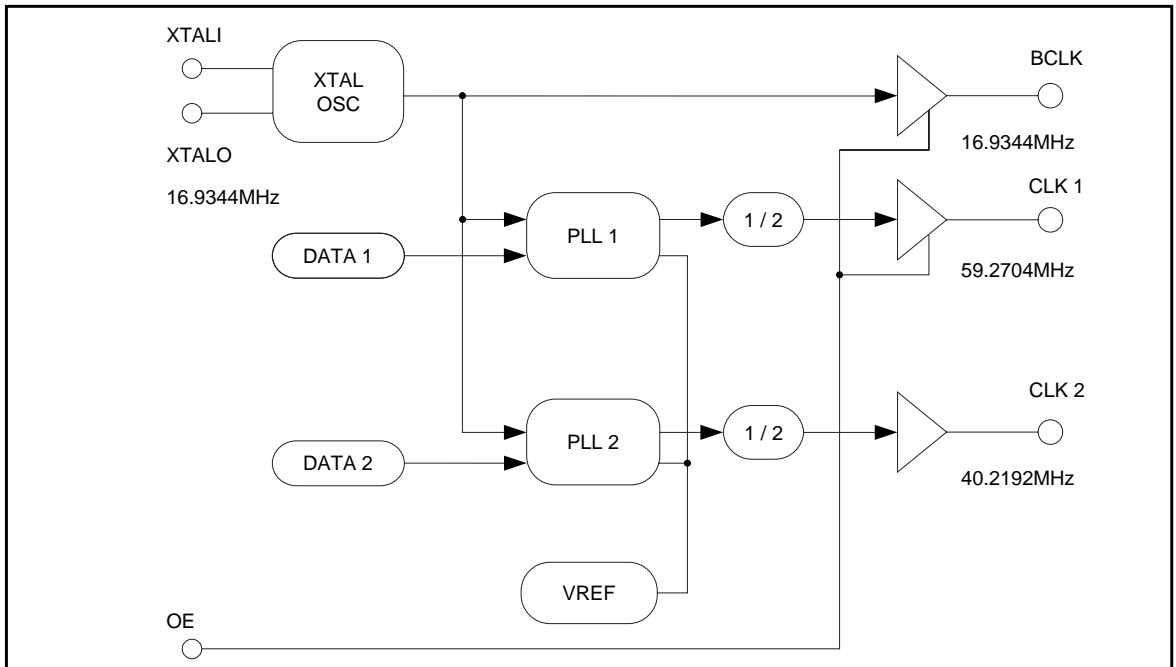

●Pin descriptions

Pin No.	Pin name	Function	Circuit
1	CLK2	Clock output 2 (f2 = 40.2192MHz)	B
2	GND	Ground	—
3	XTALI	Reference oscillation input	C
4	XTALO	Reference oscillation output	C
5	BCLK	Reference oscillation buffer output (fBCLK = 16.9344MHz)	B
6	CLK1	Clock output 1 (f1 = 59.2704MHz)	B
7	V _{DD}	V _{DD}	—
8	OE	Output enable OE = H BCLK, CLK1, CLK2, enable OE = L BCLK, CLK1, disable, CLK2, enable	A

●Absolute maximum ratings (Ta = 25°C)

Parameter	Symbol	Limits	Unit
Applied voltage	V _{DD}	- 0.5 ~ + 7.0	V
Input voltage	V _{IN}	- 0.5 ~ V _{DD} + 0.5	V
Storage temperature	T _{stg}	- 30 ~ + 125	°C
Power dissipation	P _D	450	mW

* Does not represent guaranteed performance

* Reduced by 4.5mW for increase in Ta of 1°C over 25°C.

○ Not designed for radiation resistance.

●Recommended operating conditions (Ta = 25°C)

Parameter	Symbol	Limits	Unit
Power supply voltage	V _{DD}	4.5 ~ 5.5	V
Input high level voltage	V _{IH}	0.8 × V _{DD} ~ V _{DD}	V
Input low level voltage	V _{IL}	0.0 ~ 0.2 × V _{DD}	V
Operating temperature	Topr	- 5 ~ + 70	°C
Output load	CL	15 (Max.)	pF

●Input / output circuits

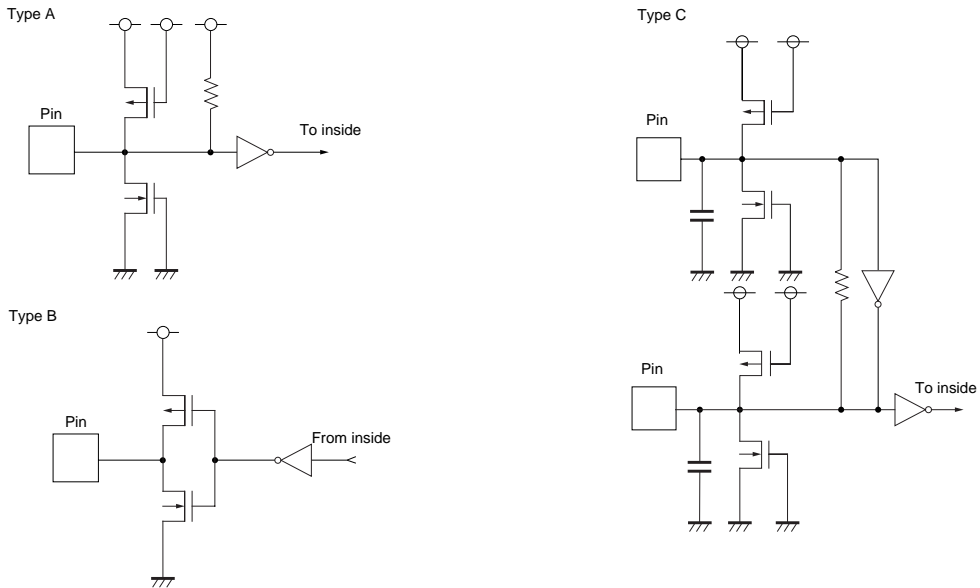

●Electrical characteristics (unless otherwise noted, Ta = 25°C, VDD = 5.0V)

Parameter	Symbol	Min.	Typ.	Max.	Unit	Conditions
Input low level current	I _{IL}	- 125	- 65.5	- 50.0	μA	V _{IN} = 0V 5V / 65.5μA = 76KΩ
Input high level current	I _{IH}	- 1.0	0.0	1.0	μA	V _{IN} = 5V
Input low level voltage	V _{IL}	—	—	0.3 × V _{DD}	V	
Input high level voltage	V _{IH}	0.7 × V _{DD}	—	—	V	
Output low level voltage	V _{OL}	—	—	0.5	V	I _{OL} = 4.0mA
Output high level voltage	V _{OH}	0.7 × V _{DD}	—	—	V	I _{OH} = - 4.0mA
Operating circuit current	I _{DD}	—	30	50	mA	f _X TAL = 16.9344MHz, no load
Reference frequency (1)	f _{REF}	16.91	16.9344	16.95	MHz	
Output frequency (1)	f _{BCK}	16.91	16.9344	16.95	MHz	
Output frequency (2)	f ₁	- 100ppm	59.2704	+ 100ppm	MHz	f _{REF} × 28 / 4 / 2
Output frequency (3)	f ₂	- 100ppm	40.2192	+ 100ppm	MHz	f _{REF} × 19 / 4 / 2
Output frequency (4)	f _{BLK1}	16.80	16.9344	17.00	MHz	V _{DD} = 3.3V
Output frequency (5)	f ₁₋₁	30.00	59.2704	57.2	MHz	V _{DD} = 3.3V
Output frequency (6)	f ₂₋₁	20.00	40.2192	40.3	MHz	V _{DD} = 3.3V
Duty	DUTY	40	50	60	%	Measure at 1 / 2V _{DD}
Jitter	J1S	—	50	—	psec	Reference value (1sigma)
Jitter	Jabs	—	600	—	psec	Reference value (min.-to-max. width for jitter)
Power up time	T _{pt}	—	2	—	ms	Reference value
XTAL1 equivalent capacitance	C _{IN}	—	10	—	pF	Reference value (pin-to-pin capacitance + internal capacitance)
XTAL0 equivalent capacitance	C _{OUT}	—	10	—	pF	Reference value (pin-to-pin capacitance + internal capacitance)

●Application example

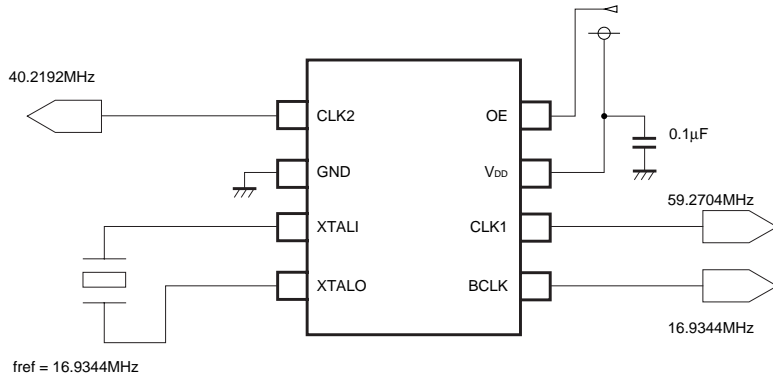

* This IC should be used mounted to a PC board.
If used mounted by a socket, the proper characteristics may not be able to be obtained.

●Attached components

(1) Crystal oscillator

A crystal resonator with an oscillation frequency of 16.9344MHz is usually sufficient. However, if fo precision is necessary, adjust by attaching a capacity to each end of the crystal oscillator.

(2) Power supply

V_{DD} bypass capacitor

●External dimensions (Units: mm)

