

Digital transistors (built in resistor)

DTA124TH / DTA124TE / DT124TUA / DTA124TKA / DTA124TSA

●Features

- 1) Built-in circuit enables the configuration of an inverter circuit without connecting external input resistors.
(see equivalent circuit).
- 2) The bias resistors consist of thin-film resistors with complete isolation to allow positive biasing of the input. They also have the advantage of almost completely eliminating parasitic effects.
- 3) Only the on / off conditions need to be set for operation, making device design easy.

●Equivalent circuit

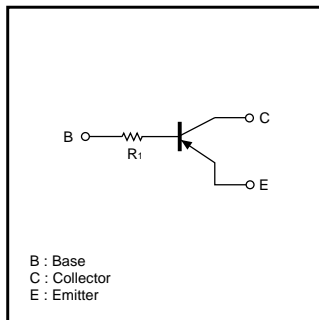

●External dimensions (Units : mm)

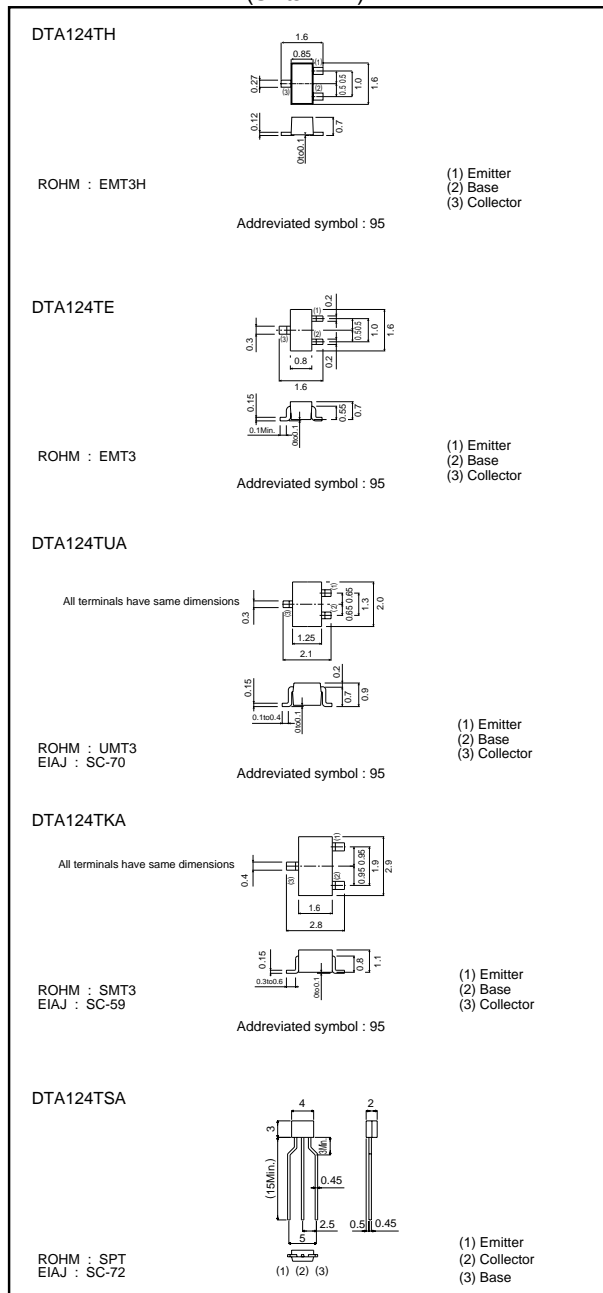

DTA124TH / DTA124TE / DTA124TUA / DTA124TKA / DTA124TSA

Transistors

●Absolute maximum ratings (Ta=25°C)

Parameter	Symbol	Limits(DTA124T□)				Unit
		H	E	UA	KA	
Collector-base voltage	V _{CB0}	-50				V
Collector-emitter voltage	V _{CE0}	-50				V
Emitter-base voltage	V _{EB0}	-5				V
Collector current	I _c	-100				mA
Collector power dissipation	P _c	150	200		300	mW
Junction temperature	T _j	150				°C
Storage temperature	T _{stg}	-55~+150				°C

●Electrical characteristics (Ta=25°C)

Parameter	Symbol	Min.	Typ.	Max.	Unit	Conditions
Collector-base breakdown voltage	BV _{CB0}	-50	-	-	V	I _c =-50μA
Collector-emitter breakdown voltage	BV _{CE0}	-50	-	-	V	I _c =-1mA
Emitter-base breakdown voltage	BV _{EB0}	-5	-	-	V	I _E =-50μA
Collector cutoff current	I _{cBO}	-	-	-0.5	μA	V _{CB} =-50V
Emitter cutoff current	I _{EBO}	-	-	-0.5	μA	V _{EB} =-4V
Collector-emitter saturation voltage	V _{CE(sat)}	-	-	-0.3	V	I _c /I _B =-5mA/-0.5mA
DC current transfer ratio	h _{FE}	100	250	600	-	V _{CE} =-5V, I _c =-1mA
Input resistance	R _i	15.4	22	28.6	kΩ	-
Transition frequency	f _r	-	250	-	MHz	V _{CE} =-10V, I _E =5mA, f=100MHz *

* Transition frequency of the device

●Packaging specifications

Part No.	Package	EMT3H	EMT3	UMT3	SMT3	SPT
		Package type	Taping	Taping	Taping	Taping
	Code	T2L	TL	T106	T146	TP
	Basic ordering unit (pieces)	8000	3000	3000	3000	5000
DTA124TH		○	-	-	-	-
DTA124TE		-	○	-	-	-
DTA124TUA		-	-	○	-	-
DTA124TKA		-	-	-	○	-
DTA124TSA		-	-	-	-	○

●Electrical characteristic curves

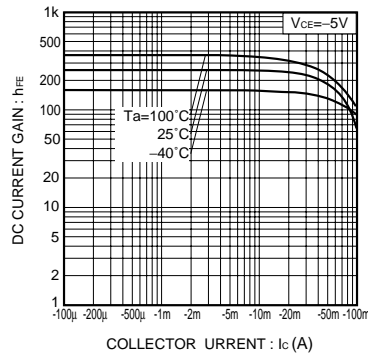

Fig.1 DC current gain vs. collector current

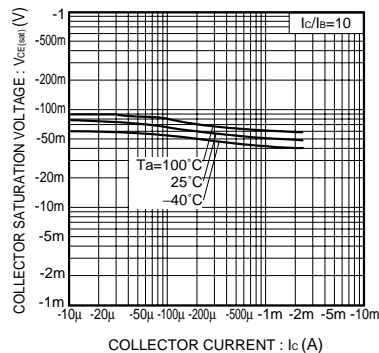

Fig.2 Collector-emitter saturation voltage vs. collector current