

Flat displays

LD-101 Series

The LD-101 series were designed in response to the need for small, flat displays. These are single-chip, flat displays with high luminance.

●Features

- 1) Planar emission from a single chip.
- 2) Thin outer casing, multiple units can be coupled together.

●External dimensions (Units : mm)

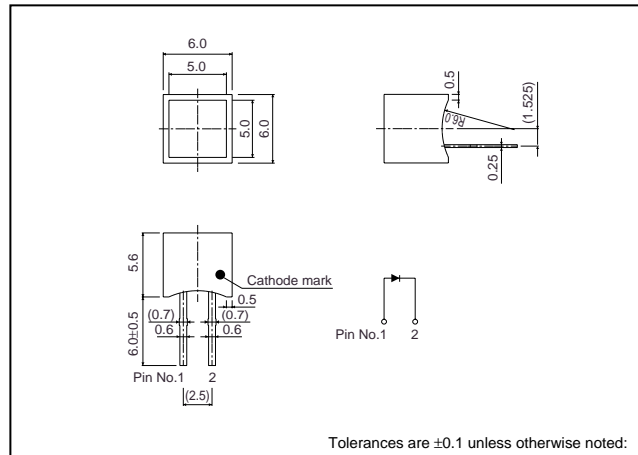

●Selection guide

Emitting color	Red	Orange	Yellow	Green
Type	LD-101VR	LD-101DU*	LD-101YY*	LD-101MG

* Order-based production.

●Absolute maximum ratings (Ta = 25°C)

Parameter	Symbol	Red	LD-101VR	Orange	LD-101DU	Yellow	LD-101YY	Green	LD-101MG	Unit
Power dissipation	P _D		60		60		60		75	mW
Forward current	I _F		20		20		20		25	mA
Peak forward current	I _{FP}		60*		60*		60*		60*	mA
Reverse voltage	V _R		3		3		3		3	V
Operating temperature	T _{opr}	-25~+75								°C
Storage temperature	T _{stg}	-30~+85								°C

* Pulse width 1ms duty 1 / 5

LED displays

● Electrical and optical characteristics (Ta = 25°C)

Parameter	Symbol	Conditions	Red			Orange			Yellow			Green			Unit
			Min.	Typ.	Max.	Min.	Typ.	Max.	Min.	Typ.	Max.	Min.	Typ.	Max.	
Forward voltage	V _F	I _F = 10mA	–	2.0	2.8	–	2.0	2.8	–	2.1	2.8	–	2.1	2.8	V
Reverse current	I _R	V _R = 3V	–	–	10	–	–	10	–	–	10	–	–	10	μA
Peak wavelength	λ _P	I _F = 10mA	–	650	–	–	610	–	–	585	–	–	563	–	nm
Spectral line half width	Δλ	I _F = 10mA	–	40	–	–	40	–	–	40	–	–	40	–	nm

● Luminous intensity vs. wavelength

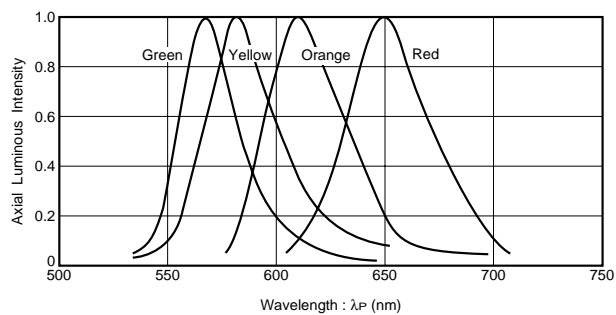

● Luminous intensity

Color	Type	Min.	Typ.	Max.	Unit
Red	LD-101VR	0.9	2.5	–	mcd
Orange	LD-101DU	0.9	2.5	–	mcd
Yellow	LD-101YY	0.9	2.5	–	mcd
Green	LD-101MG	1.4	4.0	–	mcd

Note : Measured at I_F = 10mA

● Operation notes

When forming leads, the bend should be at least 2mm from the base of the package. Solder after forming the leads, and ensure that the inside of the LED is not subjected to mechanical stress while it is hot.