

# Flat displays

## LD-603 Series

The LD-603 series were designed in response to the need for large, flat displays. These are two-chip, flat displays with high luminance.

### ●Features

- 1) 6.8×13.8mm planar emission from two chips connected in series.
- 2) High luminance, uniform planar emission
- 3) Thin outer casing, multiple units can be coupled together.
- 4) Four colors are available : red, orange, yellow and green.

### ●External Dimensions (Units : mm)

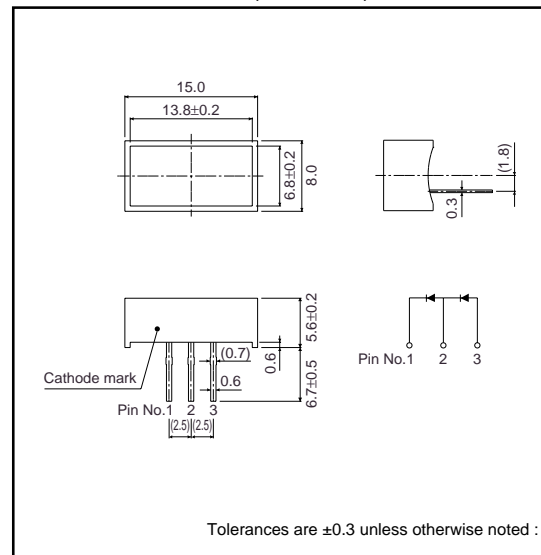

### ●Selection guide

Emitting color	Red	Orange	Yellow	Green
Type	LD-603VR	LD-603DU *	LD-603YY *	LD-603MG

\* Order-based production.

### ●Absolute maximum ratings (Ta=25°C)

Parameter	Symbol	Red	LD-603VR	Orange	LD-603DU	Yellow	LD-603YY	Green	LD-603MG	Unit
Power dissipation	P <sub>D</sub>		120		120		120		150	mW
Forward current	I <sub>F</sub>		20		20		20		25	mA
Peak forward current	I <sub>FP</sub>		60*		60*		60*		60*	mA
Reverse voltage	V <sub>R</sub>		3		3		3		3	V
Operating temperature	T <sub>opr</sub>	-25~+75								°C
Storage temperature	T <sub>stg</sub>	-30~+85								°C

\* Pulse width 1ms duty 1 / 5

## LED displays

## ●Electrical and optical characteristics (Ta=25°C)

Parameter	Symbol	Conditions	Red			Orange			Yellow			Green			Unit
			Min.	Typ.	Max.	Min.	Typ.	Max.	Min.	Typ.	Max.	Min.	Typ.	Max.	
Forward voltage	$V_F$	$I_F=10\text{mA}$	–	4.0	5.6	–	4.0	5.6	–	4.2	5.6	–	4.2	5.6	V
Reverse current	$I_R$	$V_R=3\text{V}$	–	–	10	–	–	10	–	–	10	–	–	10	$\mu\text{A}$
Peak wavelength	$\lambda_P$	$I_F=10\text{mA}$	–	650	–	–	610	–	–	585	–	–	563	–	nm
Spectral line half width	$\Delta\lambda$	$I_F=10\text{mA}$	–	40	–	–	40	–	–	40	–	–	40	–	nm

Electrical and optical are guaranteed values per element.

## ●Luminous intensity vs. wavelength

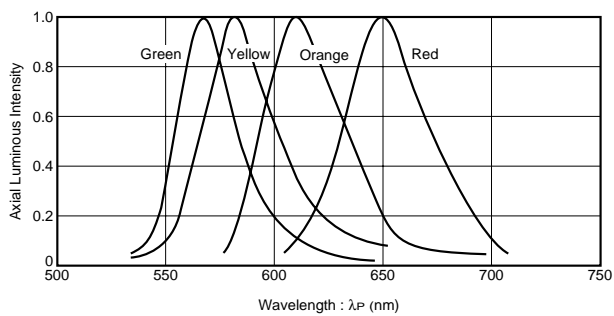

## ●Luminous intensity

Color	Type	Min.	Typ.	Max.	Unit
Red	LD-603VR	1.4	4.0	–	mcd
Orange	LD-603DU	2.2	6.3	–	mcd
Yellow	LD-603YY	2.2	6.3	–	mcd
Green	LD-603MG	2.2	6.3	–	mcd

Note 1: Measured at  $I_F = 10\text{mA}$

Note 2: Current passes through 2 elements.

## ●Operation notes

When forming leads, the bend should be at least 2 mm from the base of the package. Solder after forming the leads, and ensure that the inside of the LED is not subjected to mechanical stress while it is hot.