

MECHANICAL DATA

Dimensions in mm

HERMETICALLY SEALED
DUAL FAST RECOVERY
SILICON RECTIFIER
FOR HI-REL APPLICATIONS

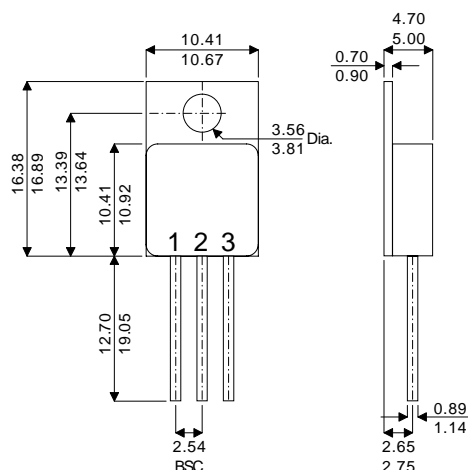

Pin 1 – Anode
 Pin 2 – Centre Tap
 Pin 3 – Cathode

TO-220XM

- Reverse Connected version of BYV32-xxx RM product
- Tab TO-220M (Isolated) (XM) and Tabless (XTM) package options

FEATURES

- HERMETIC TO220 METAL PACKAGE
- SCREENING OPTIONS AVAILABLE
- ALL LEADS IOLATED FROM CASE
- VOLTAGE RANGE 50 TO 200V
- AVERAGE CURRENT 20A
- VERY LOW REVERSE RECOVERY TIME – $t_{rr} = 35ns$
- VERY LOW SWITCHING LOSSES

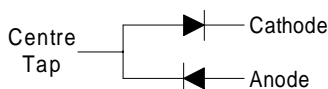

Pin 1 – Anode
 Pin 2 – Centre Tap
 Pin 3 – Cathode

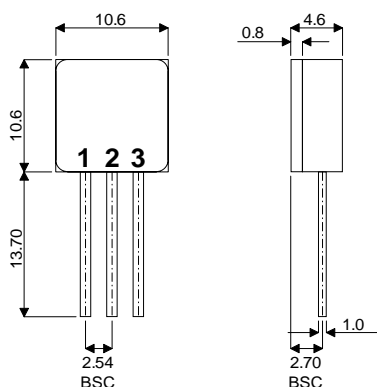

TO-220TXM

ABSOLUTE MAXIMUM RATINGS ($T_{case} = 25^{\circ}C$ unless otherwise stated)

	BYV32 -50M	BYV32 -100M	BYV32 -150M	BYV32 -200M
V_{RRM} Peak Repetitive Reverse Voltage	50V	100V	150V	200V
V_{RWM} Working Peak Reverse Voltage	50V	100V	150V	200V
V_R Continuous Reverse Voltage	50V	100V	150V	200V
I_{FRM} Repetitive Peak Forward Current $t_p = 10\mu s$	200A			
$I_{F(AV)}$ Average Forward Current $T_{case} = 70^{\circ}C$ (switching operation, $\delta = 0.5$, both diodes conducting)	20A			
I_{FSM} Surge Non Repetitive Forward Current $t_p = 10 ms$	80A			
T_{stg} Storage Temperature Range	-65 to 200°C			
T_j Maximum Operating Junction Temperature	200°C			

ELECTRICAL CHARACTERISTICS (Per Diode) ($T_{case} = 25^{\circ}C$ unless otherwise stated)

Parameter	Test Conditions	Min.	Typ.	Max.	Unit
I_R Reverse Current	$V_R = V_{RWM}$ $T_j = 25^{\circ}C$			30	μA
	$V_R = V_{RWM}$ $T_j = 100^{\circ}C$			0.6	mA
V_F * Forward Voltage	$I_F = 8A$ $T_C = 25^{\circ}C$			1.1	V
	$I_F = 20A$ $T_C = 25^{\circ}C$			1.5	
	$I_F = 5A$ $T_C = 100^{\circ}C$			0.95	
t_{rr} Reverse Recovery Time	$I_F = 2A$ $V_R = 30V$ $di / dt = 20A/\mu s$			35	ns
	$I_F = 1A$ $V_R = 30V$ $di / dt = 50A/\mu s$			50	ns
Q_{rr} Recovered Charge	$I_F = 2A$ $V_R = 30V$ $di / dt = 20A/\mu s$			15	nC
V_{FP} Forward Recovery Overvoltage	$di / dt = 50A/\mu s$ $I_F = 1A$		1.0		V

* Pulse Test: $t_p \leq 300\mu s$, duty cycle $\leq 2\%$.

THERMAL CHARACTERISTICS

$R_{\theta JC} \dagger$ Thermal Resistance Junction – Case			1.6	$^{\circ}C/W$
--	--	--	-----	---------------

\dagger Both diodes conducting.