

TOP VIEW

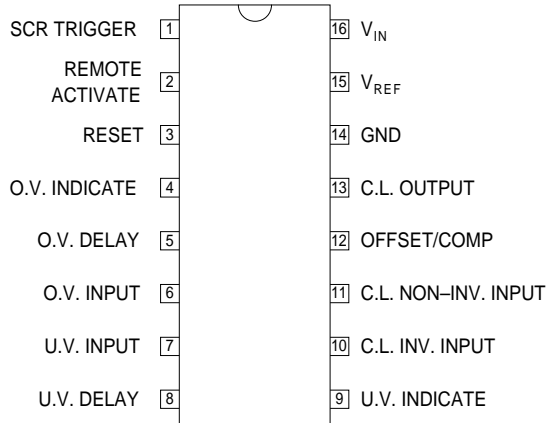

- J Package – 16 Pin Ceramic DIP
- N Package – 16 Pin Plastic DIP
- D Package – 16 Pin Plastic (300) SOIC

POWER SUPPLY SUPERVISORY CIRCUIT

FEATURES

- 4.5 to 40V operation over full temperature range
- Reference voltage trimmed to 1% accuracy
- Includes over-voltage, under-voltage and current sensing
- Programmable time delays
- SCR “Crowbar” drive of 300mA
- Remote activation capability
- Optional over-voltage latch capability

Order Information

Part Number	J-Pack 16 Pin	N-Pack 16 Pin	D-16 16 Pin	Temp. Range
IP1543	✓			-55 to +125°C
IP3543	✓	✓	✓	0 to +70°C

Note:
To order, add the package identifier to the part number.
eg. IP1543J
IP3543D-16

ABSOLUTE MAXIMUM RATINGS (T_{case} = 25°C unless otherwise stated)

+V _{IN}	Input Supply Voltage	40V
	Sense Inputs	V _{IN}
	SCR Trigger Current	Internally Limited
	Indicator Output Voltage	+40V
	Indicator Output Sink Current	50mA
P _D	Power Dissipation	T _A = 25°C Derate @ T _A > 50°C
		1W 10mW/°C
P _D	Power Dissipation	T _C = 25°C Derate @ T _C > 25°C
		2W 16mW/°C
T _J	Operating Junction Temperature	See Ordering Information
T _{STG}	Storage Temperature Range	-65 to +150°C
T _L	Lead Temperature (soldering, 10 seconds)	+300°C

DESCRIPTION

The IP1543 and IP3543 power supply supervisory circuits contain all the functions necessary to monitor and control the output of a sophisticated power supply system. Included on the chip are over-voltage (O.V.) sensing with externally programmable delay used to trigger an external SCR "Crowbar", under-voltage (U.V.) sensing with externally programmable delay used to sense either the power supply output or the line input voltage, a third op-amp/comparator with provision for external compensation and/or offset programming used for either current limiting or as an additional voltage monitor, and a voltage reference trimmed to $\pm 1\%$.

BLOCK DIAGRAM

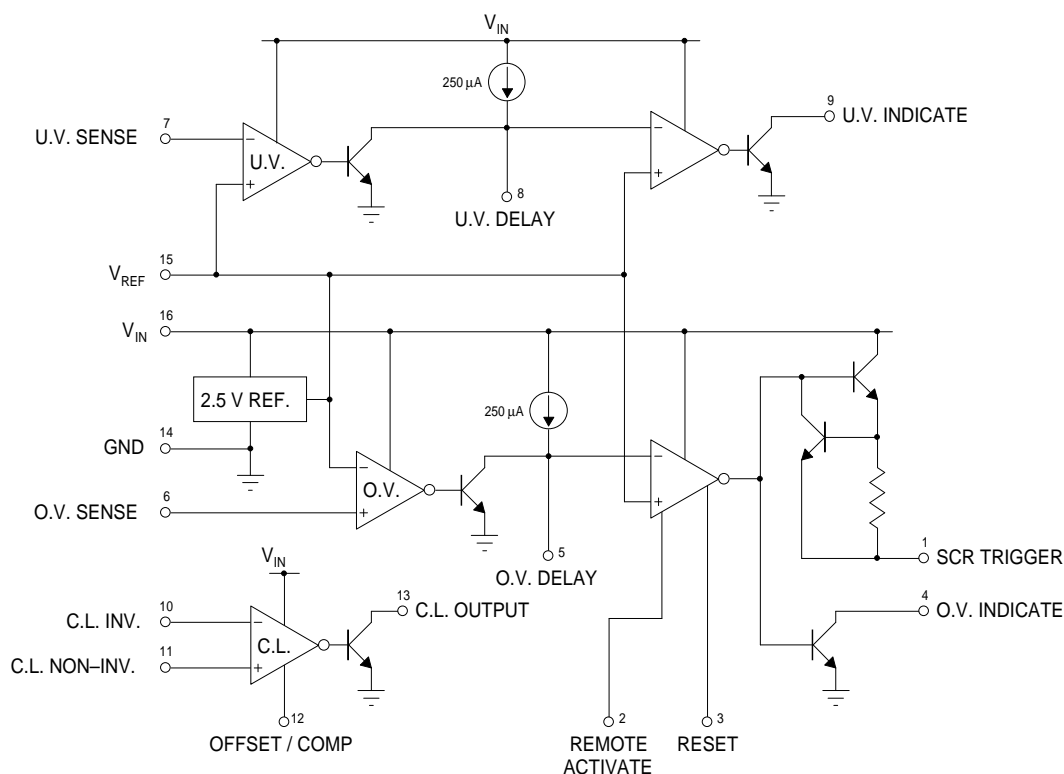

RECOMMENDED OPERATING CONDITIONS

V_{IN}	Input Supply Voltage		+4.5 to +40V
	Input Voltage Range		0 to $V_{IN} - 3$
	Reference Load Current		0 to 10mA
	Indicate Output Current		0 to 10mA
	Operating Ambient Temperature Range	IP1543	-55 to +125°C
		IP3543	0 to +70°C

ELECTRICAL CHARACTERISTICS (T_J = Over Operating Temperature Range unless otherwise stated)

Parameter	Test Conditions	IP1543			IP3543			Units
		Min.	Typ.	Max.	Min.	Typ.	Max.	
Input Voltage Range		4.5		40	4.5		40	V
Supply Current	$V_{IN} = 40V$		7	10		7	10	mA
REFERENCE SECTION								
Output Voltage	$T_J = 25^\circ C$	2.48	2.5	2.52	2.45	2.5	2.55	V
		2.45		2.55	2.4		2.6	
Line Regulation	$V_{IN} = 4.5$ to $30V$		1	5		1	5	mV
Load Regulation	$I_{REF} = 0$ to $10mA$		1	10		1	10	
Short Circuit Current	$V_{REF} = 0$	12	25	40	12	25	40	mA
Temperature Stability			50			50		ppm/ $^\circ C$
SCR TRIGGER SECTION								
Peak Output Current	$V_{IN} = 5V$ $R_G = 0$ $V_O = 0$	100	200	400	100	200	400	mA
Peak Output Voltage	$V_{IN} = 15V$ $I_O = 100mA$	12	13		12	13		V
Output Off Voltage	$V_{IN} = 40V$		0	0.1		0	0.1	
Remote Activate Current	Pin 2 = Gnd		-0.1	-0.8		-0.1	-0.8	mA
Remote Activate Voltage	Pin 2 = Open		1.5	6		1.5	6	V
Reset Current	Pin 3 = Gnd Pin 2 = Gnd		-0.1	-0.8		-0.1	-0.8	mA
Reset Voltage	Pin 3 = Open Pin 2 = Gnd		1.5	6		1.5	6	V
Output Current Rise Time	$R_L = 50\Omega$ $T_J = 25^\circ C$		400			400		mA/ μs
Prop. Delay from Pin 2	$C_D = 0$ $V_{PIN2} = 0.4V$ $T_J = 25^\circ C$		300			300		ns
Prop. Delay from Pin 6	$V_{PIN6} = 2.7V$ $T_J = 25^\circ C$		500			500		ns
COMPARATOR SECTIONS								
Input Threshold (Input Voltage Rising on Pin 6, Falling on Pin 7)	$T_J = 25^\circ C$	2.45	2.5	2.55	2.4	2.5	2.6	V
		2.4		2.6	2.35		2.65	
Input Hysteresis	$T_J = 25^\circ C$		25			25		mV
Input Bias Current	Sense Input = $0V$		-0.3	-1		-0.3	-1	μA
Delay Saturation			0.2	0.5		0.2	0.5	V
Delay High Level			6	8		6	8	
Delay Charging Current	$V_D = 0$	200	250	300	200	250	300	μA

ELECTRICAL CHARACTERISTICS (T_J = Over Operating Temperature Range unless otherwise stated)

Parameter	Test Conditions	IP1543			IP3543			Units
		Min.	Typ.	Max.	Min.	Typ.	Max.	
COMPARATOR SECTIONS (cont.)								
Indicate Saturation	$I_L = -10\text{mA}$	0.2	0.5		0.2	0.5		V
Indicate Leakage	$V_{IND} = 40\text{V}$	0.01	1		0.01	1		μA
Propagation Delay	$V_{PIN6} = 2.7\text{V}$ $C_D = 0$	$V_{PIN7} = 2.3\text{V}$ $T_J = 25^\circ\text{C}$			400			ns
	$V_{PIN6} = 2.7\text{V}$ $C_D = 0$	$V_{PIN7} = 2.3\text{V}$ $T_J = 25^\circ\text{C}$			10			ms
CURRENT LIMIT SECTION								
Input Voltage Range		0		$V_{IN} - 3$	0		$V_{IN} - 3$	V
Input Bias Current	Pin 12 = Open $V_{CM} = 0$	-0.3	-1		-0.3	-1		μA
Input Offset Voltage	Pin 12 = Open $V_{CM} = 0$	0	10		0	15		mV
	10k Ω from Pin 12 to Gnd	70	100	130	70	100	130	
CMRR	$V_{CM} = 0$ to 12V $V_{IN} = 15\text{V}$	60	70		60	70		dB
AVOL	Pin 12 = Open $V_{CM} = 0$	72	80		72	80		
Output Saturation	$I_L = -10\text{mA}$	0.2	0.5		0.2	0.5		V
Output Leakage	$V_{IND} = 40\text{V}$	0.01	1		0.01	1		μA
Small Signal Bandwidth	$A_V = 0\text{dB}$ $T_J = 25^\circ\text{C}$	5			5			MHz
Propagation Delay	$V_{\text{overdrive}} = 100\text{mV}$ $T_J = 25^\circ\text{C}$	200			200			ns

NOTES

1. Test Conditions unless otherwise stated:

$$V_{IN} = 10\text{V}$$

$$T_J = -55 \text{ to } +125^\circ\text{C} \quad \text{for IP1543}$$

$$T_J = 0 \text{ to } +70^\circ\text{C} \quad \text{for IP3543}$$

APPLICATIONS INFORMATION

Typical Application

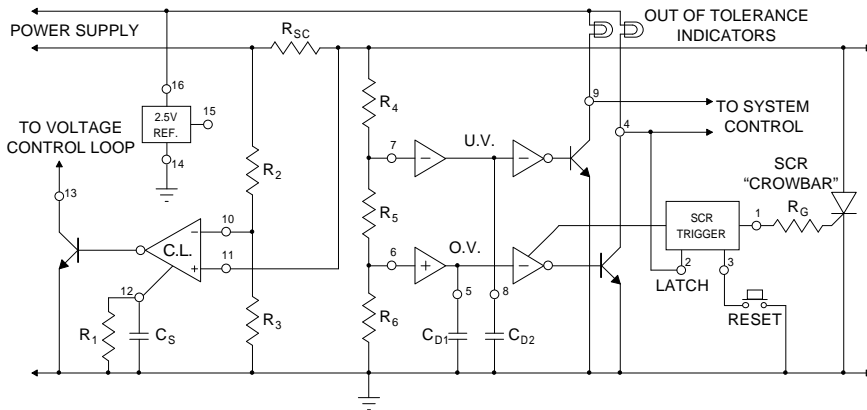

$$\text{Current Limit } V_{TH} \approx \frac{1000}{R_1}$$

C_S is determined by the current loop dynamics.

$$\text{Peak Current to load } I_p \approx \frac{V_{TH}}{R_{SC}} + \frac{V_O}{R_{SC}} \left(\frac{R_2}{R_2 + R_3} \right)$$

$$\text{Low Output Voltage Limit } V_{O(\text{low})} = \frac{2.5 (R_4 + R_5 + R_6)}{R_5 + R_6}$$

$$\text{High Output Voltage Limit } V_{O(\text{high})} = \frac{2.5 (R_4 + R_5 + R_6)}{R_6}$$

Voltage Sensing Delay $T_D = 10000 C_D$

$$\text{SCR trigger power limiting resistor } R_G > \frac{V_{IN} - 5}{0.2}$$

Sensing Multiple Supply Voltages

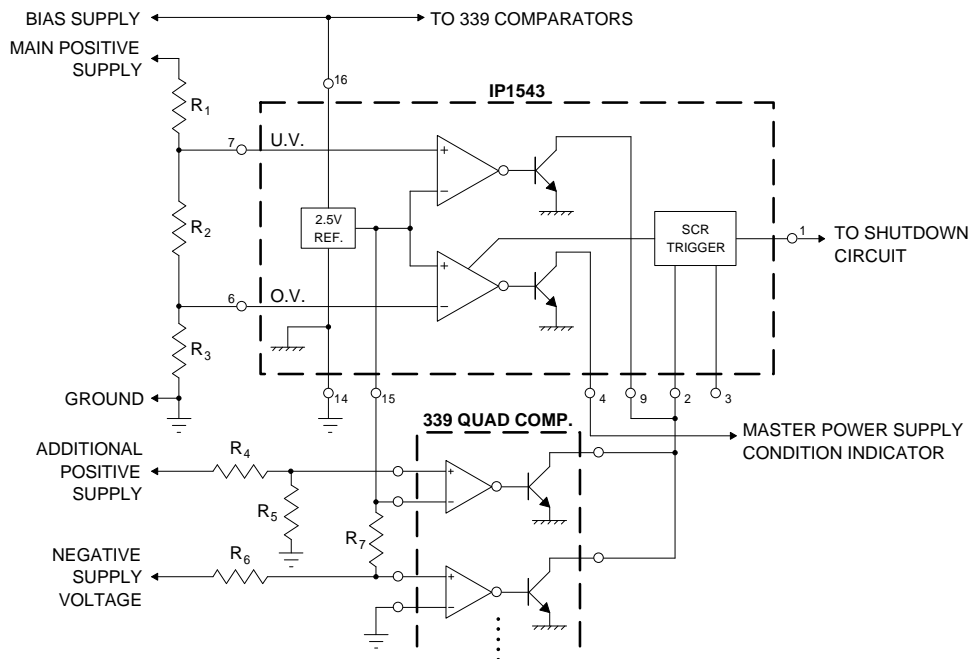

Input Line Monitor

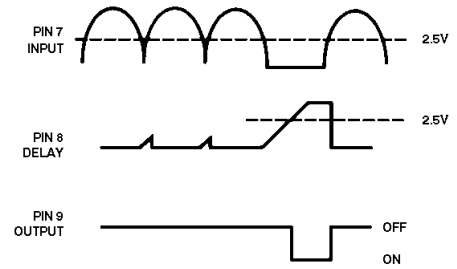
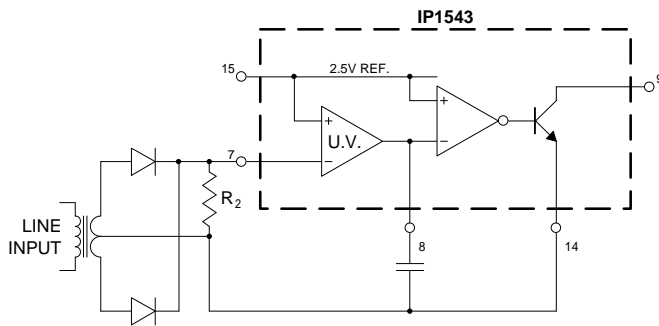

Overcurrent Shutdown

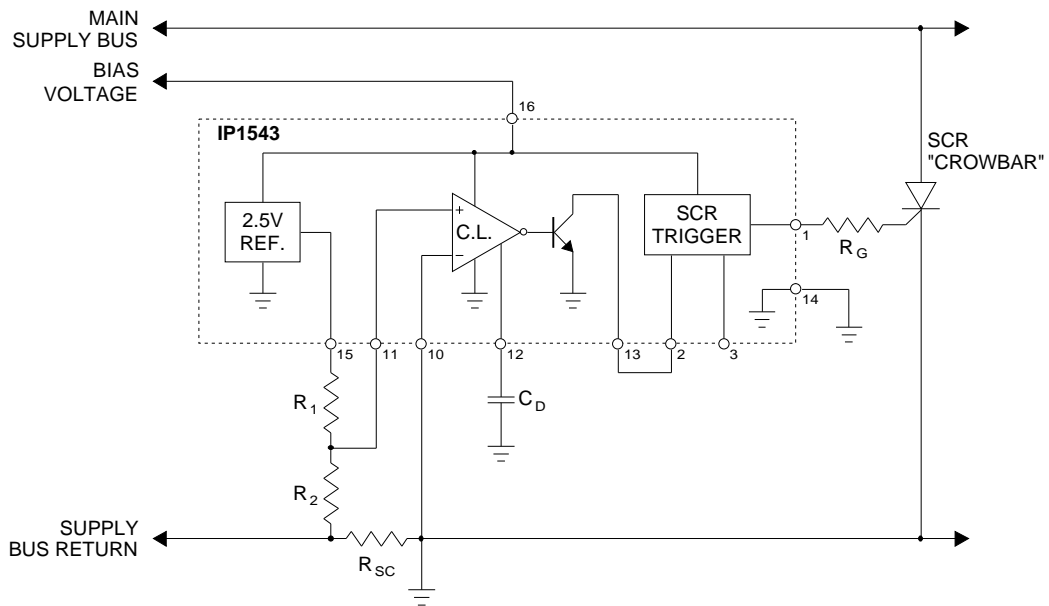

TYPICAL PERFORMANCE CHARACTERISTICS

Comparator Input Hysteresis

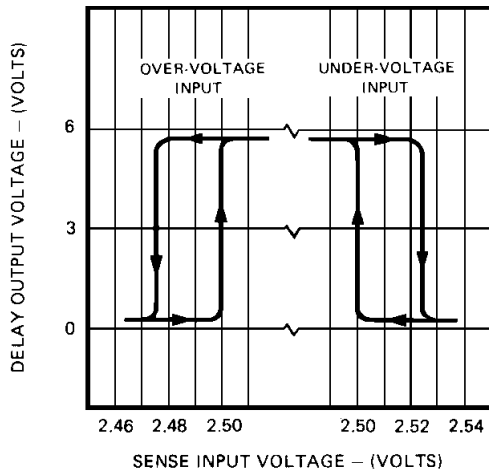

Comparator Input Hysteresis

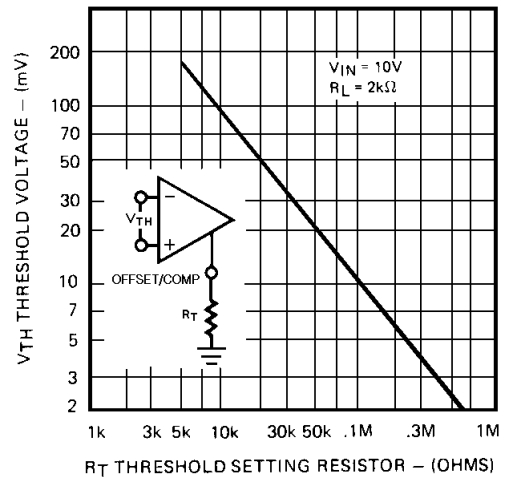

SCR Trigger Power Limiting

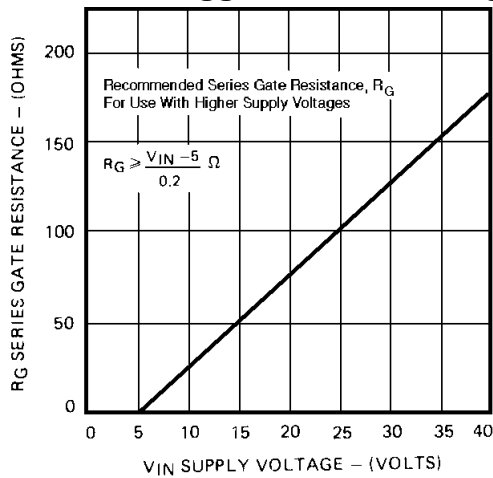

Current Limit Amplifier Gain

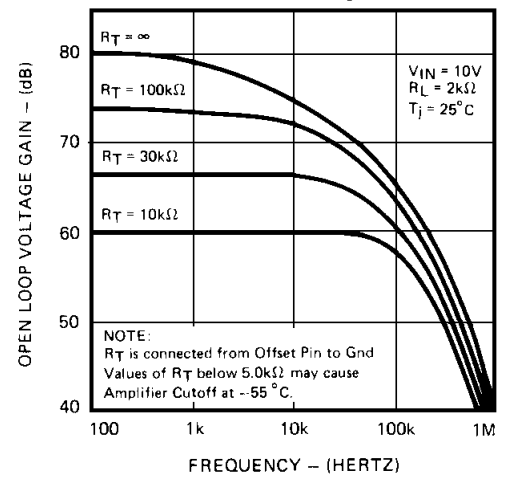

Current Limit Amplifier Frequency Response

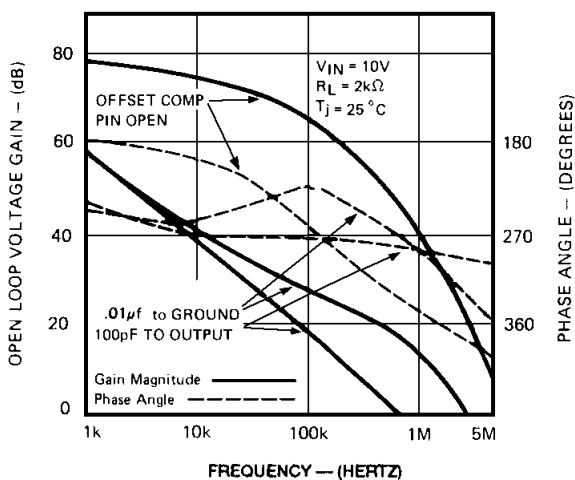

Activation Delay vs Capacitor Value

