

SANYO	No.4038	LA7916
	Peripheral Circuit for TV / VCR Frequency Synthesizer Channel Select System	

The LA7916 contains CPU/PLL-excluded peripheral circuits such as switch, +5V power supply (with RST), sync detector, low-pass filter for color TV/VTR frequency synthesizer channel select system use.

Functions

- Band switch (2-input 4-output)
- Video signal, flyback pulse, AFT output-used detection of tuning mode and horizontal sync mode
- +5V power supply, with RST output (for CPU)
- OP amp for low-pass filter (for frequency synthesizer)

Features

- The band switch truth table can be changed in a short period of time at the user's option.
- The band switch is of pnp output type which need not be driven externally.
- The OP amp for low-pass filter is excellent in pulse response because of its high-impedance input pin.

Maximum Ratings at Ta = 25°C

		Ta ≤ 65°C	unit
Allowable Power Dissipation	Pd max	770	mW
Operating Temperature	Topt	-20 to +65	°C
Storage Temperature	Tstg	-55 to +125	°C
[Band Switch Section]			
VCC1 Maximum Supply Voltage	V13 max	15	V
Maximum Load Current	I14, I15, I16, I17 max	-50	mA
Maximum Applied Voltage	V14, V15, V16, V17 max	Output off	V
Maximum Applied Voltage (Input)	V6 max, V7 max	VCC1 = 14V	12
[+5V Power Supply Section]			
VCC2 Maximum Supply Voltage	V10 max	15	V
+5V Output Current	I8 max	-38	mA
[Tuning Detection Section]			
Maximum Input Voltage	V2 max	3.5	V
Maximum Input Voltage	V3 max	VCC1	V
Maximum Input Voltage (Negative Polarity)	-V2 max	-1.4	V
Maximum Comparator Difference Voltage	V19-V20	6	V
Maximum Output Current	I1 max	-3	mA
[Operational Amplifier Section]			
Maximum Applied Voltage	V12 max	35	V
Maximum Input Voltage	V11 max	5.9	V

Package Dimensions

(unit : mm)
3021B

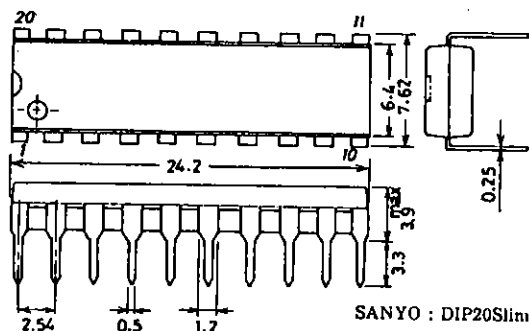

Operating Conditions at Ta = 25°C		min	typ	max	unit
Supply Voltage Range	V ₁₀	9.0	12	14.0	V
	V ₁₃	9.0	12	14.0	V
Recommended Output Current in Tuning Detection Section	I _{4, I5}			3	mA
Recommended Load Current in OP Amp Section	I ₁₂		3	5	mA
Recommended Setting Range of Comparator Voltage in Tuning Detection Section	V ₁₉	2.7		7.0	V

Operating Characteristics at Ta = 25°C		min	typ	max	unit	
[Band Switch Section]						
Quiescent Current Dissipation	I _{CC1}		16.0		mA	
Output Saturation Voltage	F1 to 4 sat	I _o = -40mA	0	0.7	V	
Input 'H'-Level Voltage	V _{6TH, V7TH}		2.2		V	
Input 'L'-Level Voltage	V _{6TL, V7TL}		0	0.8	V	
Output Leakage Current	I _{FL}	-15V		-50	μA	
[+5V Power Supply Section]						
Quiescent Current Dissipation	I _{CC2}		3.6		mA	
+5V Output Voltage	V ₈	I _g = -30mA	4.5	5.5	V	
RST Output Voltage	V _{9 sat}	I _g = -100μA	4.5	5.5	V	
[Tuning Detection Section]						
Input Threshold Voltage	V _{2TH}		0.4	0.72	1.5	V
Comparator Voltage	V _{C19}		3.7	4.0	4.3	V
Window Comparator 'H' Voltage	V _{CH}		5.7	6.0	6.3	V
Window Comparator 'L' Voltage	V _{CL}		2.7	3.0	3.3	V
Output Saturation Voltage	V _{4 sat}	I _{sink} = 2mA	0	0.33	0.7	V
	V _{5 sat}	I _{sink} = 2mA	0	0.33	0.7	V
Low-Pass Filter Output Current	I _{OL}		-1.80	-0.90	mA	
Sync Separation Start Current	I _{1TH}		-150		μA	
[Operational Amplifier Section]						
Output Saturation Voltage	V _{12 sat}		0	0.3	V	
Input Threshold Voltage	V _{11TH}		2.0	2.4	V	
Input Current	I ₁₁			20	nA	

Band Switch Truth Table

Input		Output			
A (Pin 7)	B (Pin 6)	F1 (Pin 14)	F2 (Pin 15)	F3 (Pin 16)	F4 (Pin 17)
L	L	H	Z	Z	Z
H	L	Z	H	Z	Z
L	H	Z	Z	H	Z
H	H	Z	Z	Z	H

Operation of Tuning Detection Section

Tuning Mode	LPF Output	AFT	OUT 1	OUT 2
Unsynchronized	L	AFT-L	L	L
		AFT-C	L	L
		AFT-H	L	L
Synchronized	H	AFT-L	H	L
		AFT-C	H	H
		AFT-H	L	H

AFT-L: V_{AFT} < V_{CL}
 AFT-C: V_{CL} < V_{AFT} < V_{CH}
 AFT-H: V_{AFT} > V_{CH}

LA7916

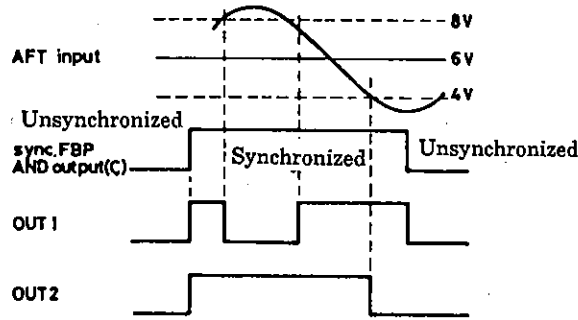

+5V Power Supply, $\overline{\text{RST}}$ Output

When +5V output V_8 becomes approximately 4V at the time of application of power, the reset signal is delivered at pin 9. The reset signal can be delayed by a capacitor (recommended value : $1\mu\text{F}$) externally connected to $\overline{\text{RST}}$ output V_9 .

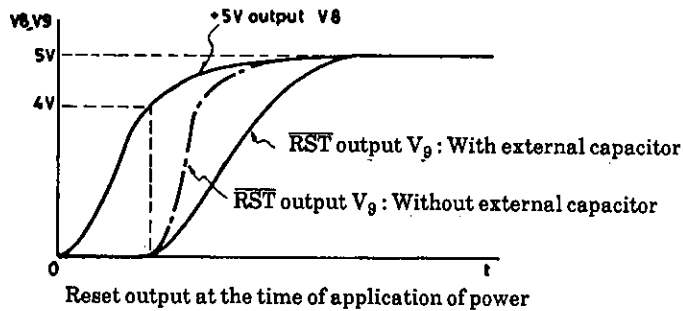

Sample Application Circuit

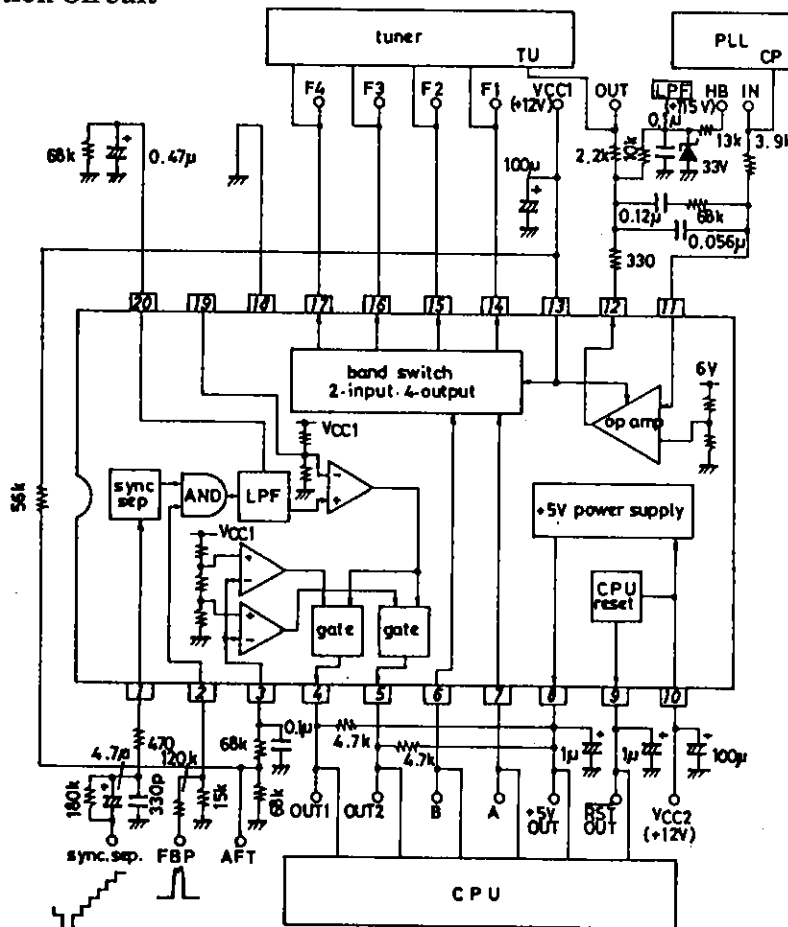

VTR application: In VTR applications without flyback pulse, connected pin 2 to V_{CC} through a resistor

Unit (resistance: Ω , capacitance:F)

- No products described or contained herein are intended for use in surgical implants, life-support systems, aerospace equipment, nuclear power control systems, vehicles, disaster/crime-prevention equipment and the like, the failure of which may directly or indirectly cause injury, death or property loss.
- Anyone purchasing any products described or contained herein for an above-mentioned use shall:
 - ① Accept full responsibility and indemnify and defend SANYO ELECTRIC CO., LTD., its affiliates, subsidiaries and distributors and all their officers and employees, jointly and severally, against any and all claims and litigation and all damages, cost and expenses associated with such use:
 - ② Not impose any responsibility for any fault or negligence which may be cited in any such claim or litigation on SANYO ELECTRIC CO., LTD., its affiliates, subsidiaries and distributors or any of their officers and employees jointly or severally.
- Information (including circuit diagrams and circuit parameters) herein is for example only; it is not guaranteed for volume production. SANYO believes information herein is accurate and reliable, but no guarantees are made or implied regarding its use or any infringements of intellectual property rights or other rights of third parties.

This catalog provides information as of **June, 1996**. Specifications and information herein are subject to change without notice.