

SANYO	No. 4927	STK672-010
	Unipolar Fixed-Current Chopper (separate excitation) Type 1.7 A Output Current Stepping Motor Driver with Built-in 4-Phase Distribution Controller	

Overview

The STK672-010 is a 4-phase stepping motor driver IC that adopts power MOSFET for its output stage and that uses a unipolar fixed-current chopper scheme. Since the STK672-010 includes a built-in 4-phase distribution controller, the stepping motor driver circuit and the control scheme can be simplified, and the stepping motor driver circuit structure can be standardized. The STK672-010 provides high torque, low vibration, and rapid response based on a W1-2 phase excitation drive scheme. The motor current is voluntary set from externals. Since, compared to the earlier STK6770 Series, the STK672-010 has a smaller package size and reduced drive power dissipation (reduced by 70% over previous products), it provides a wider operating power supply voltage range.

Applications

- Send/receive stepping motors in facsimile equipment
- Stepping motor drive for paper feed and optical systems in copier, and drum drive in laser beam printers
- Pen drive in X-Y plotters
- Industrial robots and other stepping motor application products

Features

- The STK672-010 can easily implement stepping motor drive applications with the provision of a DC power supply and a clock pulse oscillator.
- <4-Phase Distribution Controller>
- The STK672-010 supports four excitation types selected by the excitation mode setting (M1 and M2).
 1. 4-phase 1 excitation
 2. 4-phase 1-2 excitation
 3. 4-phase 2 excitation
 4. 4-phase W1-2 excitation
 - Schmitt input pins (for a high noise margin)
 - Controller inputs are CMOS compatible (with built-in pull-up resistors), thus allowing direct control from I/O ports or special-purpose controller LSIs.
 - An interval is set up during mutual switching of the \overline{AA} and \overline{BB} phase output signals in 4-phase 2 excitation mode.

<Driver Circuits>

- Since the STK672-010 is a separate excitation type circuit, it supports a wide operating power supply voltage range. ($V_{CC1} = 5$ to 42 V)
- Current detection resistors are provided within the hybrid IC.
- Drive power reduced by 70% when compared to the STK6770 Series (at 1 A drive).
- Can provide a motor drive current of up to 1.7 A without a heat sink.

Package Dimensions

unit: mm

4149

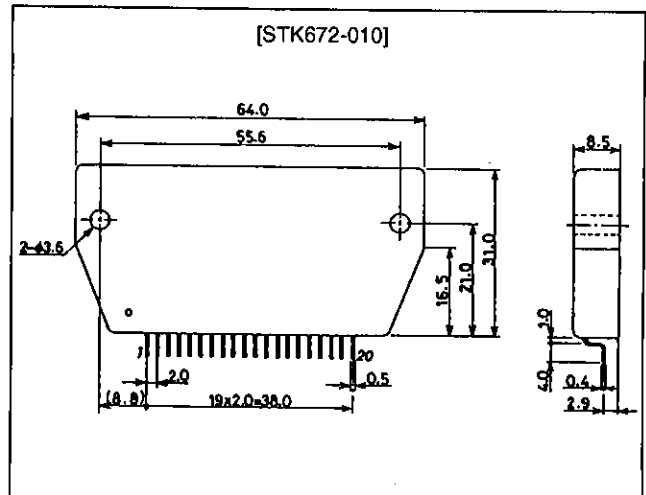

Specifications

Absolute Maximum Ratings at Ta = 25°C

Parameter	Symbol	Conditions	Ratings	Unit
Maximum supply voltage	V _{CC1} max	No signal	52	V
	V _{CC2} max	No signal	7.0	V
Maximum phase output current	I _{OH} max	0.5 s, 1 pulse	2.5	A
Repeat avalanche capacity	E _{ar} max		38	mJ
Input voltage	V _{IN} max		7.0	V
Operating substrate temperature	T _c max		105	°C
Junction temperature	T _j max		150	°C
Storage temperature range	T _{stg}		-40 to +125	°C

Allowable Operating Ranges at Ta = 25°C

Parameter	Symbol	Conditions	Ratings	Unit
Operating supply voltage	V _{CC1}	With a signal present	18 to 42	V
	V _{CC2}	With a signal present	5 ± 5%	V
Input voltage	V _{IH}		0 to V _{CC2}	V
Phase drive withstand voltage	V _{DSS}		120	V
Phase current	I _{OH} max	Duty: 50% per phase	1.7	A

Electrical Characteristics at Ta = 25°C, V_{CC1} = 36 V, V_{CC2} = 5 V

Parameter	Symbol	Conditions	min	typ	max	Unit
Output saturation voltage	V _{st}	R _L = 23 Ω		1.1	1.5	V
Output current (average)	I _{oave}	Load (each phase): R = 3.5 Ω, L = 3.8 mH	0.45	0.50	0.59	A
FET diode forward voltage	V _{df}	I _f = 1.0 A		1.2	1.8	V
Current when stopped	I _{cco}			36	55	mA
On input voltage	V _{IH}	Pins 14, 15, 16, 17, 18, and 19	4.0			V
Off input voltage	V _{IL}	Pins 14, 15, 16, 17, 18, and 19			1.0	V
Input leakage current	I _I	Pins 14, 15, 16, 17, 18, and 19	-600		+30	μA
C1 to C3 high level voltage	V _{OH}	Pins 1, 2, and 3	2.4			V
C1 to C3 low level voltage	V _{OL}	Pins 1, 2, and 3			0.4	V
Chopping frequency	f _c	R/C: 2.4 kΩ/6800 pF	35	42	50	kHz

AC Characteristics at Ta = 25°C, V_{CC1} = 36 V, V_{CC2} = 5.0 V, C_L = 50 pF

Parameter	Symbol	Conditions	min	typ	max	Unit
Delay time	T _{pd1}	For the clock path: CLK → A, \bar{A} , B, \bar{B}		2		μs
	T _{pd2}	For the clock path: CLK → C1, C2, C3			2	μs
Output signal interval	T _{in}	Only for 4-phase 2 excitation	20		40	μs
Maximum clock frequency	f _{CLK}				20	kHz

Note: Use a rated power supply.

Definition of the Delay Time T_{pd}

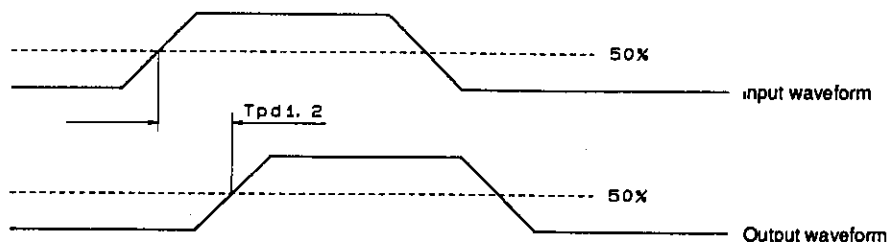

A02541

Definition of the Output Signal Interval T_{in}

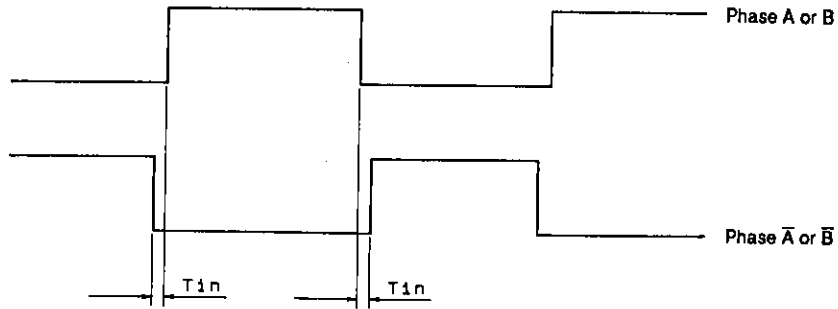

A02542

Function Table

Operating Mode

	\overline{CW}/CCW	START/STOP
CW	L	L
CCW	H	L
STOP	X	H

Excitation Mode

	M1	M2
4-phase 1 excitation	L	L
4-phase 2 excitation	H	L
4-phase 1-2 excitation	L	H
4-phase W1-2 excitation	H	H

Equivalent Circuit

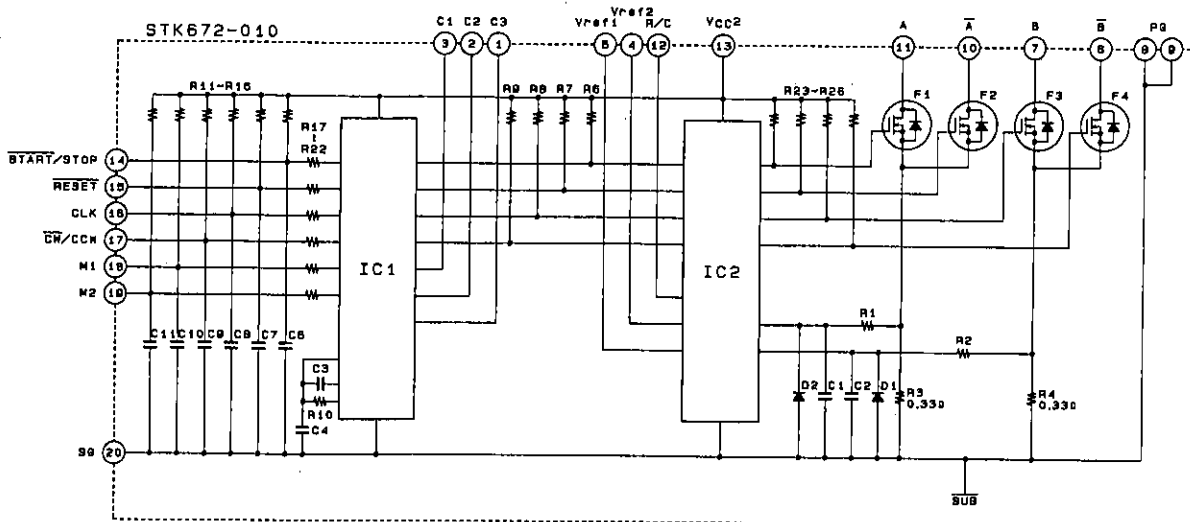

A02042

STK672-010

Sample Application Circuit (W1-2 phase excitation, motor current: four stage switching)

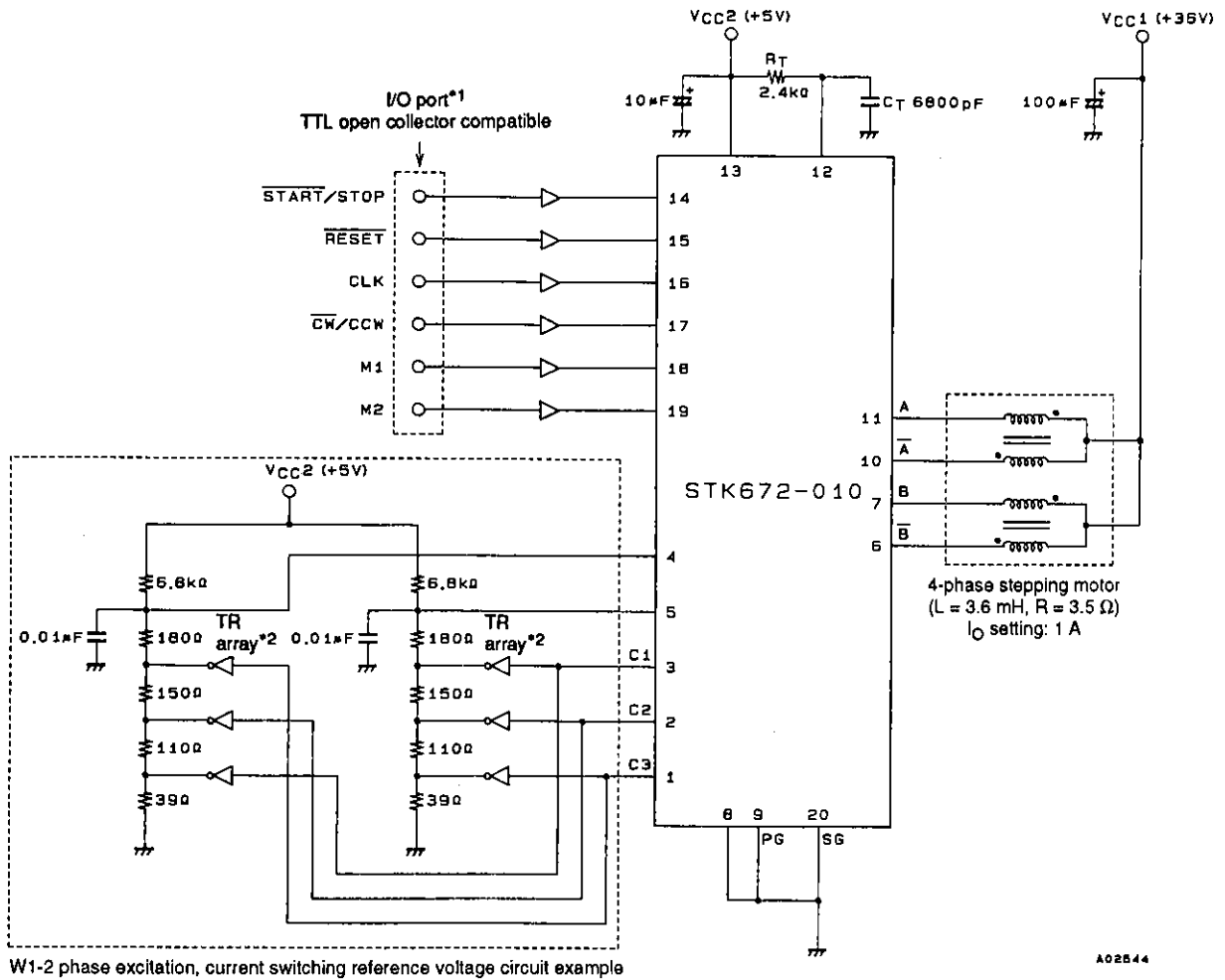

- Note: 1. See the function tables and the timing chart for details on the I/O port signals.
 2. Use the Sanyo LB1212, LB1214, or equivalent for the TR array.
 3. The RESET pin should normally be left open.

STK672-010 Operation

<Separate Excitation Chopper Driver Block Operation>

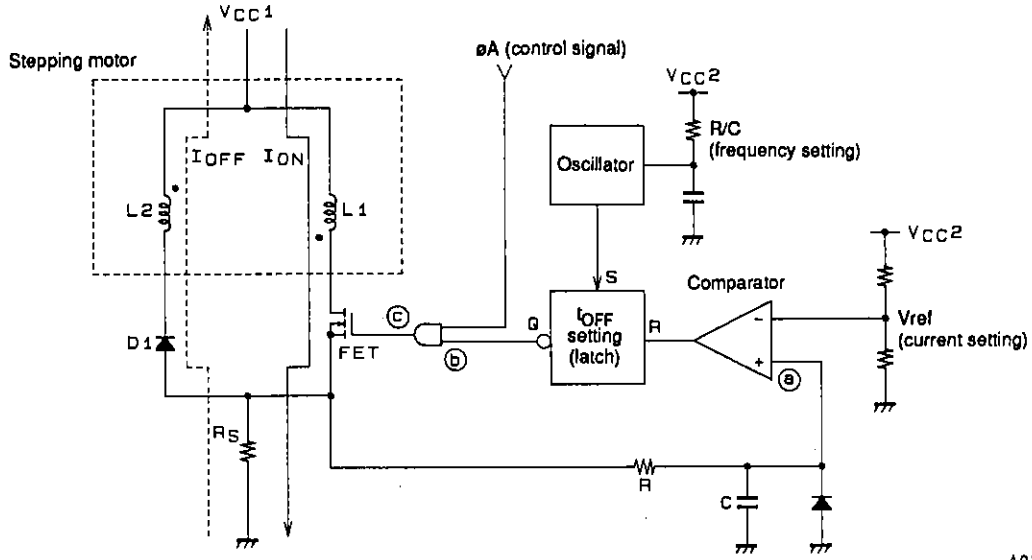

A02545

Fig. 1 STK672-010 Driver Block Basic Circuit

Figures 1 and 2 show the driver block basic circuit and the waveforms in the various blocks.

Unlike the earlier STK6710 Series, which adopted MOSFET transistors, the STK672-010 implements a fixed current drive scheme with separate excitation.

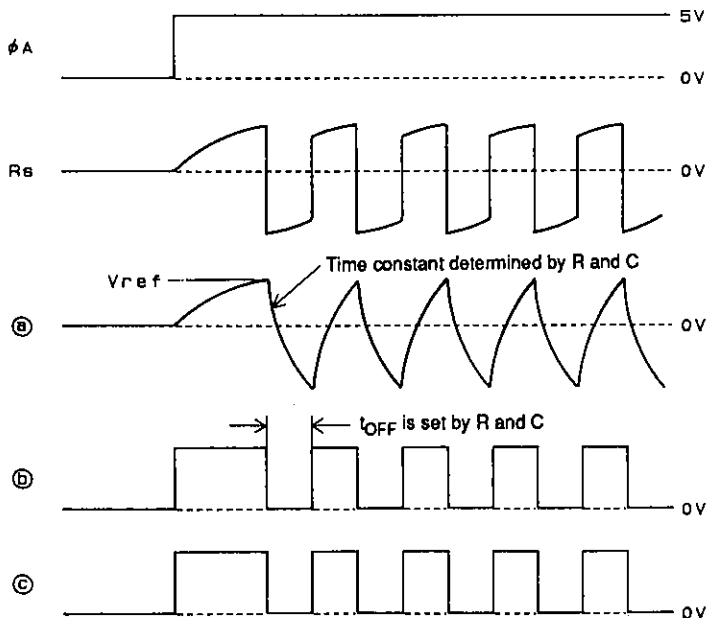

Fig. 2 Waveform Timing Chart

A02546

When the FET is turned on by a high level input on the φA signal in the driver block basic circuit, the comparator + pin goes low and the comparator output goes low. The L1 current ION that flows in the FET at this time is given by the following formula.

$$I_{ON} = \frac{V_{CC1} - V_{sat}}{R} (1 - e^{-\frac{R}{L}t}) \dots \dots \dots (1)$$

L: Coil inductance

R: The sum of the coil resistance and Rs

Then, when the Rs voltage becomes equal to Vref, the FET turns off. At this point the energy stored in the inductor L1 induces a current in L2 and the current IOFF flows. The time that the current IOFF flows is proportional to the off time set at the oscillator.

Thus the chopping operation is partially fixed at the oscillator frequency by the latch function.

The STK672-010 repeats the operation of switching the motor current on and off, i.e., fixed current chopping operation, as described above.

<4-Phase Distribution Control Logic Block Operation>

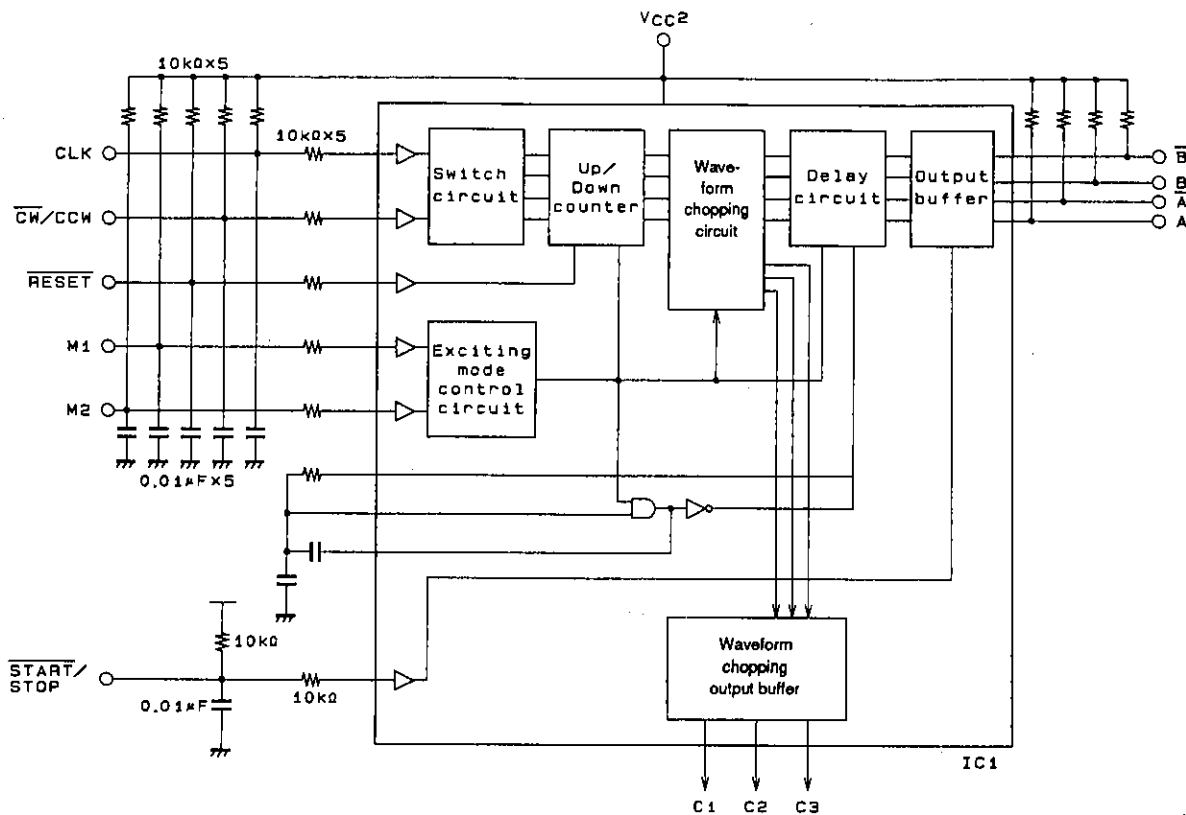

A02547

Fig. 3 Control Logic Circuit

The control logic IC built into the STK672-010 is a special-purpose IC developed to allow stepping motors to be operated more simply than was possible previously.

Features

- One of four excitation types can be selected with the excitation mode setting (M1 and M2).
 1. 4-phase 1 excitation
 2. 4-phase 1-2 excitation
 3. 4-phase 2 excitation
 4. 4-phase W1-2 excitation
- Schmitt circuits are provided on all input pins (for a high noise margin).
- Inputs have 10 kΩ pull-up resistors built in so that they are CMOS and TTL input compatible. Thus the inputs can be driven directly from I/O ports or special-purpose LSIs.
- The \overline{AA} and \overline{BB} phases of 4-phase control output at the 2-phase excitation set up the interval times.
- The minimum pulse width for the control logic is 25 μs. The logic operates on pulse falling edges.

The following timing charts show the logic in each excitation mode.

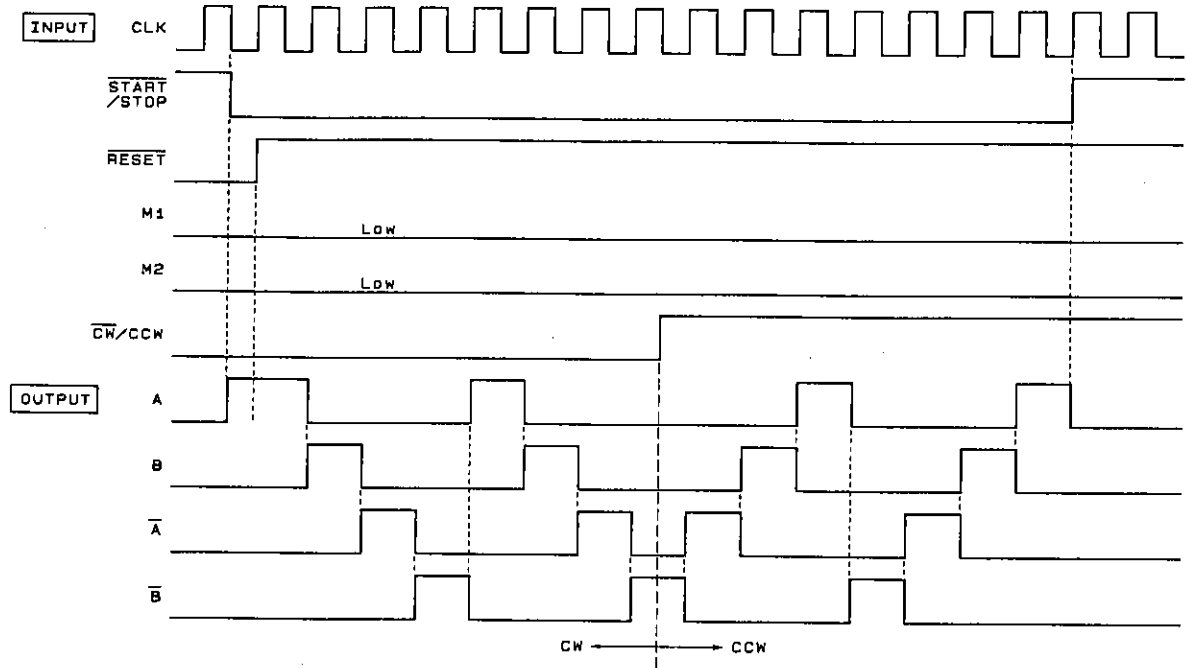

A02548

Fig. 4 4-Phase 1 Excitation Timing Chart

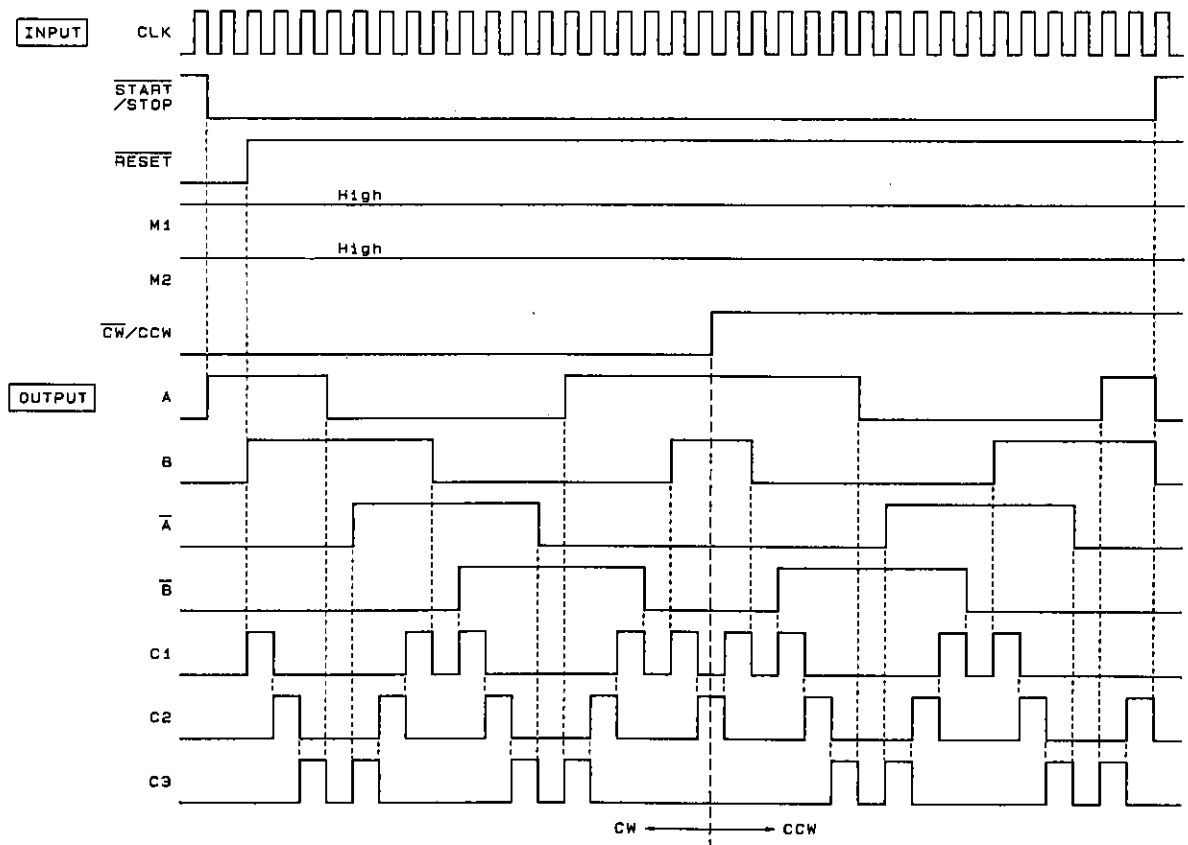

A02548

Fig. 5 4-Phase W1-2 Excitation Timing Chart

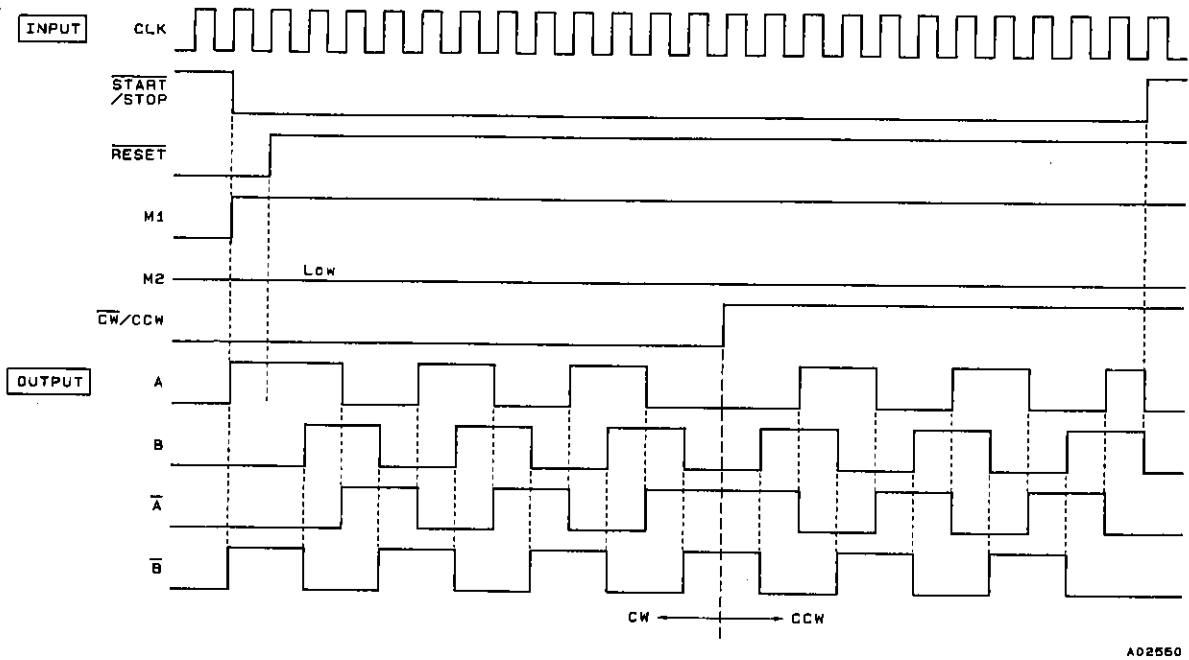

Fig. 6 4-Phase 2 Excitation Timing Chart

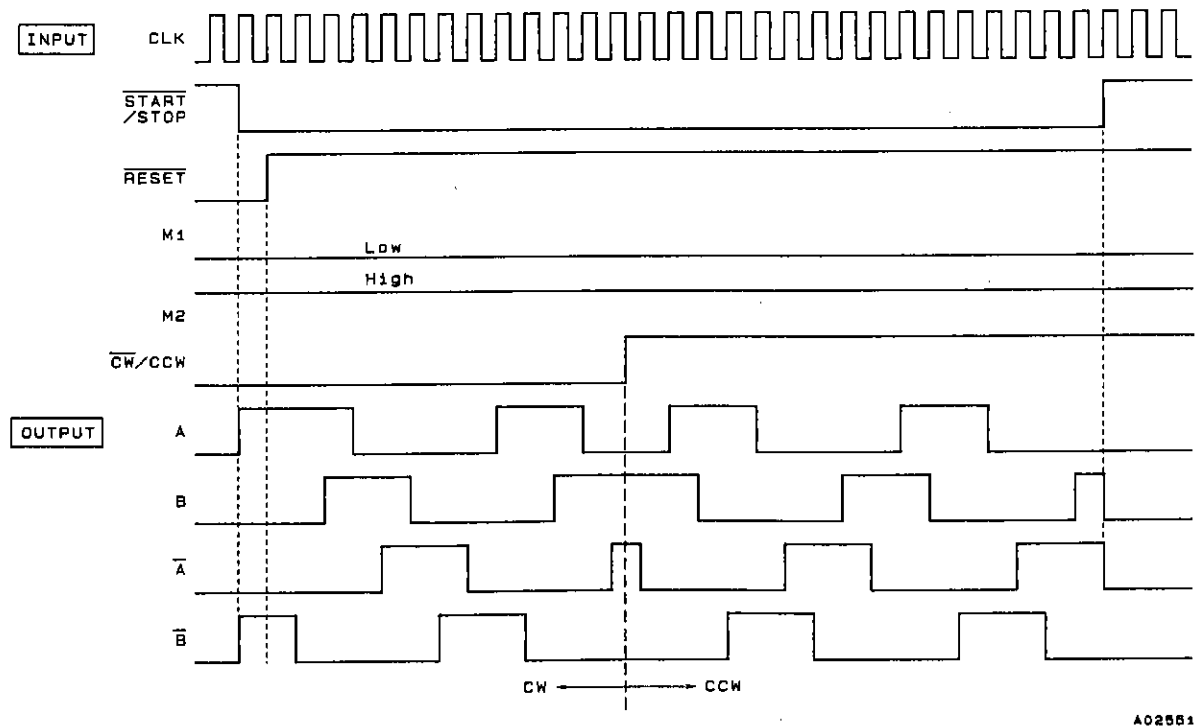

Fig. 7 4-Phase 1-2 Excitation Timing Chart

<Output Current Setting>

Figure 8 shows the motor output current waveform. The output current I_{OH} is set by the STK672-010 pin 4 (5) voltage. The formulas for these calculations are as follows.

$$V_{ref} = \frac{R_{O2}}{R_{O1} + R_{O2}} \times V_{CC2} \dots\dots\dots (2)$$

$$I_{OH} = K \times \frac{V_{ref}}{R_S} \dots\dots\dots (3)$$

R_S : The hybrid IC internal current detection resistor ($0.33 \pm 3\%$)

K : 1.1 to 1.2 (correction coefficient for differences between settings and measurements)

K is a proportionality constant that corrects for discrepancies between measurements and settings. Since the value of K is the set value in one condition, the value must be reset for each condition examined. Sources of error include motor supply voltage and the motor electrical characteristics.

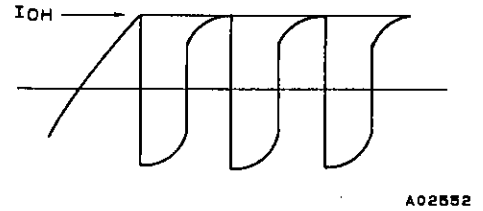

Fig. 8 Motor Output Current Waveform

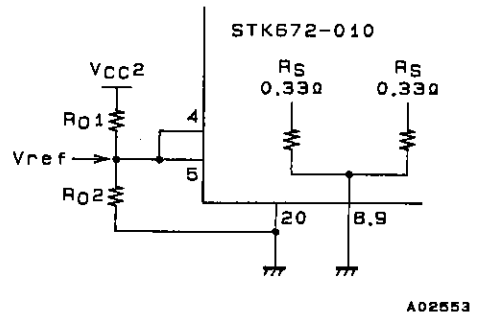

Fig. 9: Vref Peripheral Circuit

The output current range is from 0.1 A of the current caused by the t_{OFF} time in oscillator to 1.7 A of the allowable maximum current.

<Notes on W1-2 Phase Excitation Current Switching>

The STK672-010 provides the control logic circuit to allow the current to be switched over up to four levels by the C1, C2, and C3. A low saturation transistor must be used on the Vref voltage switching device in the W1-2 phase excitation circuit.

The reason for this is that when the W1-2 phase excitation current is switched over up to four levels, for switching I_O at small settings the I_O waveform will be displaced from the desired value due to variations in the $V_{CE(sat)}$ voltage drop of the external Vref switching device. This can result in increased motor vibrations. Therefore we recommend selecting a device with a $V_{CE(sat)}$ of about 10 mV at $I_C = 100 \mu A$ for this transistor at the operating conditions used for this circuit. Note that although we proposed using the LB1212 or LB1214, this does not necessarily apply to designs that take mass production into consideration.

The output current setting ratios for W1-2 phase excitation are 100%, 92%, 70%, and 38% for four-level switching and 100% and 70% for two-level switching. These are target values and precise adjustment should be made in the actual circuit.

A description of the W1-2 phase excitation follows.

<W1-2 Phase Excitation>

1. Overview

W1-2 phase excitation is a technique for acquiring 1/2 the step angle of the 1-2 phase excitation by controlling the stepping motor winding currents for each phase.

2. Basic Concepts

There are three types of W1-2 phase excitation.

A: Fixed common current form

B: Square form

C: Circle form

Figure 10 shows the concepts behind these forms.

The relation between the basic step angle θ_0 of a two (or four) phase stepping motor and W1-2 phase excitation is given by the following formula.

$$\theta = \theta_0/4$$

In A, the common current is always a fixed value, and the motor vibration is even lower than for 1-2 phase excitation since the motor current in each phase increases in a stepwise manner.

In B, the common current is 2-times or 1.41-times, and although the motor current in each phase increases in a stepwise manner, operation is rougher than type A.

In C, although the common current still increases, since the motor current in each phase increases in a stepwise manner and the form is circular, this type is effective at reducing vibration.

3. Application

Figure 11 shows the timing chart for each block, i.e., the input clock, the each phase driver input, current control, and the phase currents. Based on the clock, which is the rotate command for the distributor first stage, this circuit controls the fixed current drive currents by forming each phase input as a 1-2 phase excitation sequence and forming the current control sequence as C1, C2, and C3 in the distributor.

A: Fixed Common Current Form

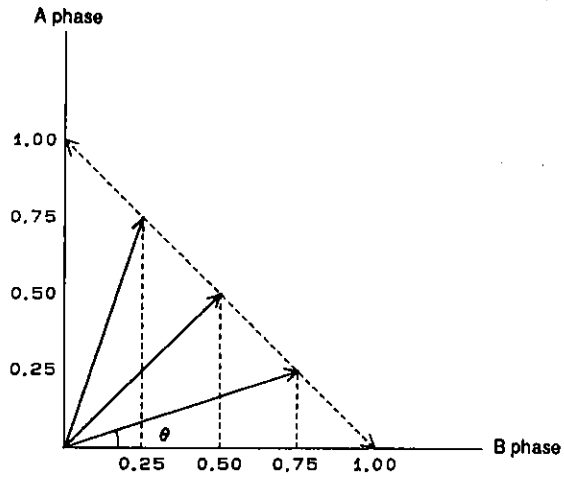

A02554

B: Square Form

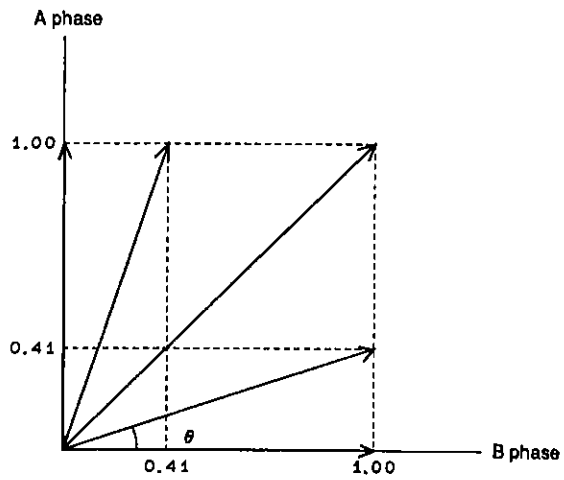

A02555

C: Circle Form

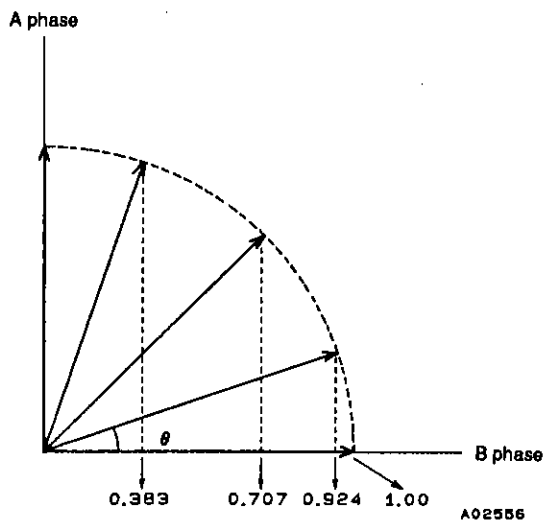

A02556

Fig. 10 W1-2 Phase Excitation Control Angle Concepts

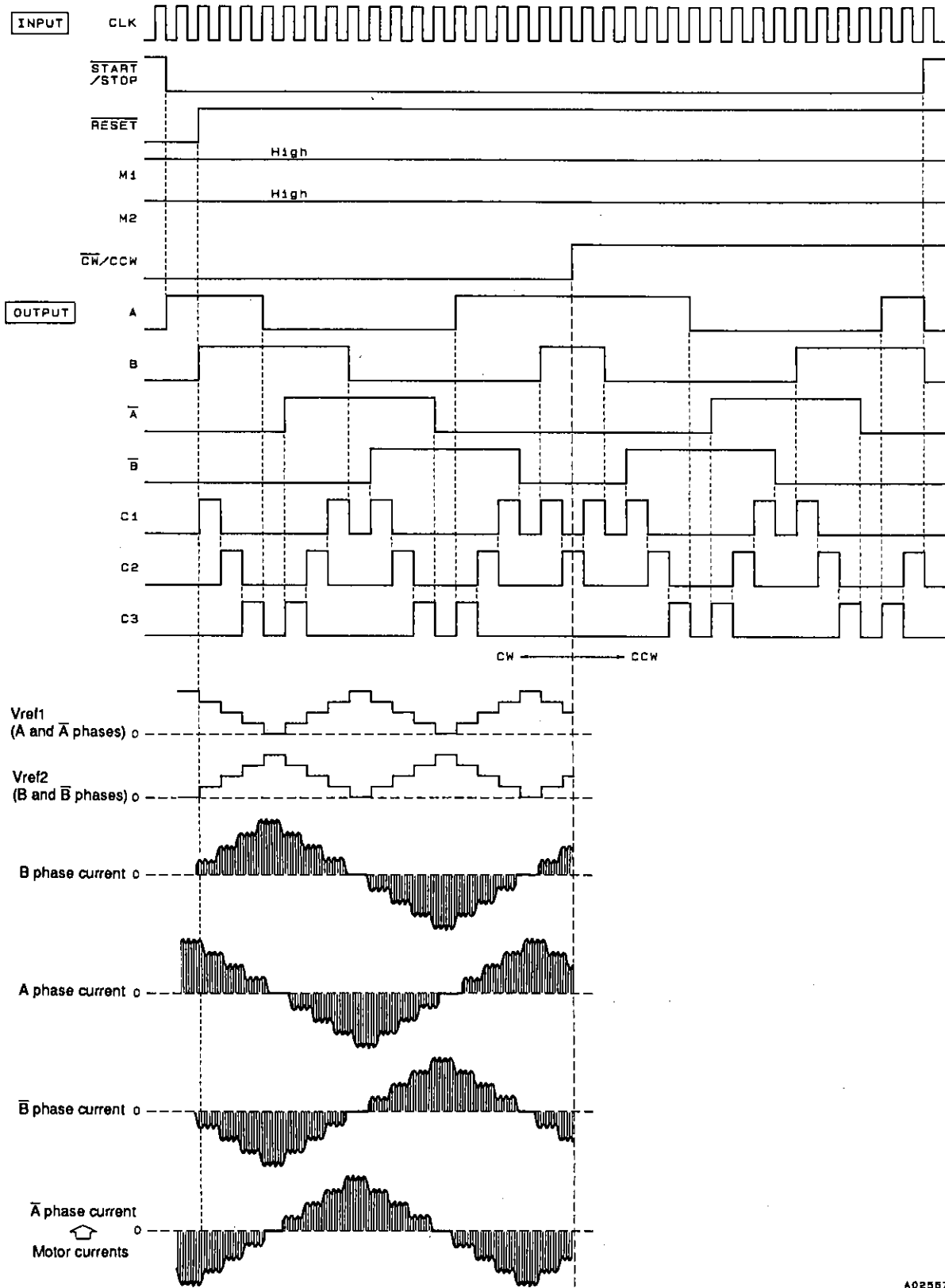

A02567

Note: Vref1 is the A and A-bar phase reference voltage.
Vref2 is the B and B-bar phase reference voltage.

Fig. 11 W1-2 Phase Excitation Timing Chart

<Oscillator Frequency Setting>

The separate excitation chopping frequency f can be derived from t_{ON} and t_{OFF} as follows.

$$t_{ON} = -CR_1 \times \ln \frac{V_L}{V_H} \dots\dots\dots (4)$$

$$t_{OFF} = -C \times \frac{R_x \times R_1}{R_1 + R_x} \times \ln \left[1 - \frac{\frac{R_x}{R_x \times R_1} \times V_{CC}^2}{0.33 \times V_{CC}^2} \right] \dots\dots\dots (5)$$

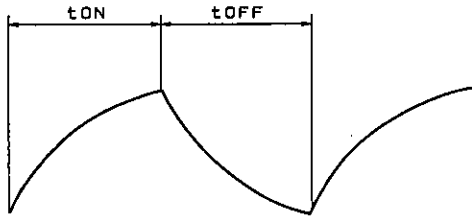

Fig. 12 R/C Waveform

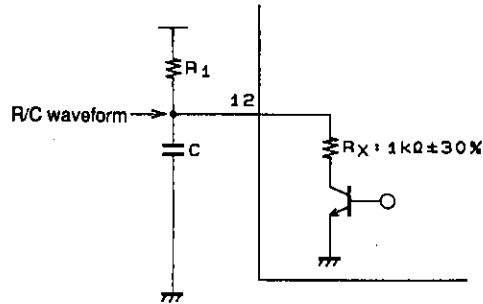

Fig. 13 R/C Pin Peripheral Circuit

Therefore, the separate excitation chopping frequency f is given by the following formula.

$$f = \frac{1}{t_{ON} + t_{OFF}} \text{ [Hz]} \dots\dots\dots (6)$$

Values of $R_1 = 2.4 \text{ k}\Omega$ and $C = 7500 \text{ pF}$ are appropriate to achieve the recommended time constant.

Thermal Design

The size of the heat sink required for this hybrid IC is determined by the motor output current I_{OH} (A), the motor's electrical characteristics, the excitation mode, and the clock frequency f_{clock} (Hz) of the excitation input signal. The thermal resistance of the required heat sink can be derived from the following formula.

$$\theta_{c-a} = \frac{T_{c \text{ max}} - T_a}{P_d} \text{ [}^\circ\text{C/W]} \dots\dots\dots (7)$$

- $T_{c \text{ max}}$ = The hybrid IC case temperature ($^\circ\text{C}$)
- T_a = Set internal temperature ($^\circ\text{C}$)
- P_d = The hybrid IC average internal power dissipation (W)

The heat sink thermal resistance θ_{c-a} can be derived from the average power dissipation shown in Figure 14. Then the heat sink area can be derived from Figure 15. Note that the ambient temperature is influenced significantly by the air circulation conditions within the set. Therefore, the heat sink size must be determined so that back surface (the aluminum plate side) of the hybrid IC never exceeds $T_{c \text{ max}}$ (105°C) under any condition in the mounted state within the end product.

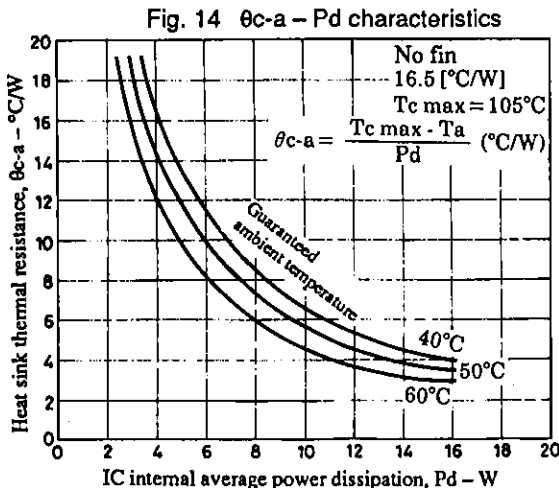

Fig. 14 $\theta_{c-a} - P_d$ characteristics

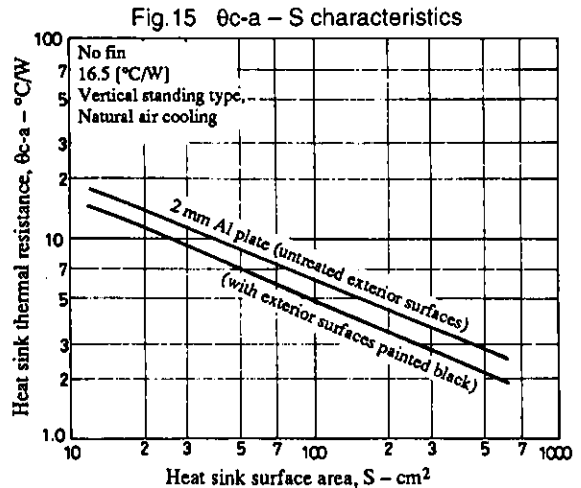

Fig. 15 $\theta_{c-a} - S$ characteristics

<Hybrid IC Internal Average Power Dissipation>

The devices with the largest power dissipations within the STK672-010 are the current control devices, the regenerated current diodes, the current detection resistors, and the pre-drive circuits.

The power dissipations for each of the excitation modes are given by the following formulas.

1 phase excitation: $Pd_{1EX} = (Vst + Vdf) \frac{f \text{ clock}}{2} I_{OH} \cdot t2 + \frac{I_{OH} \cdot f \text{ clock}}{2} (Vst \cdot t1 + Vdf \cdot t3) \dots\dots\dots (10)$

2 phase excitation: $Pd_{2EX} = (Vst + Vdf) \frac{f \text{ clock}}{2} I_{OH} \cdot t2 + \frac{I_{OH} \cdot f \text{ clock}}{2} (Vst \cdot t1 + Vdf \cdot t3) \dots\dots\dots (11)$

1-2 phase excitation: $Pd_{1-2EX} = (Vst + Vdf) \frac{f \text{ clock}}{4} I_{OH} \cdot t2 + \frac{I_{OH} \cdot f \text{ clock}}{4} (Vst \cdot t1 + Vdf \cdot t3) \dots\dots\dots (12)$

W1-2 phase excitation: $Pd_{W1-2EX} = (Vst + Vdf) \frac{0.64 \cdot f \text{ clock}}{8} I_{OH} \cdot t2 + \frac{I_{OH} \cdot f \text{ clock}}{8} (Vst \cdot t1 + Vdf \cdot t3) \dots\dots\dots (13)$

- Vst: The sum of the R_{ON} and R_S voltage drops
- Vdf: The sum of the FET internal diode and the R_S voltage drops
- f clock: Input clock

The times t1, t2, and t3 are shown in the figure below.

- t1: The time for the winding current to reach the set value
- t2: The time in the fixed current chopping region
- t3: The time from the point where the phase input signal is cut to the point where the regenerated reverse power is dissipated.

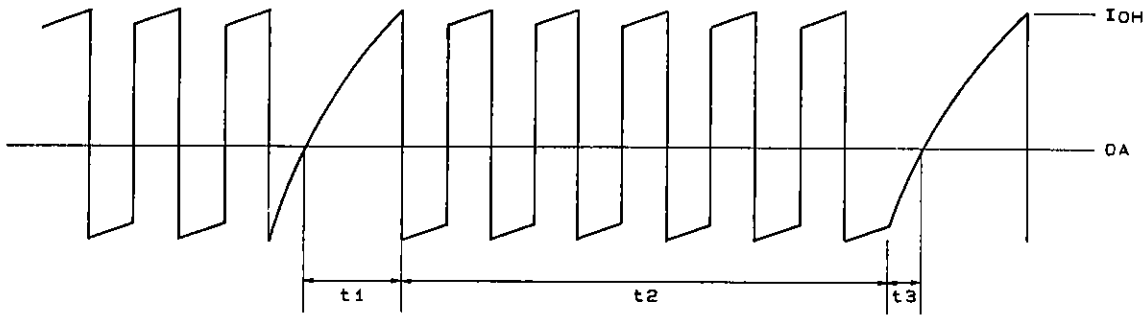

A02560

Fig. 16 Motor Output Current Waveform (idealized model)

$t1 \approx \frac{-L}{R + 0.88} \times \ln \left(1 - \frac{R + 0.88}{V_{CC}} \times I_{OH} \right) \dots\dots\dots (12)$

$t1 \approx \frac{-L}{R} \times \ln \left(\frac{V_{CC} + 0.88}{I_{OH} \times R + V_{CC} + 0.88} \right) \dots\dots\dots (13)$

- V_{CC} : Motor power supply voltage (V)
- L: Motor inductance (H)
- R: Motor internal resistance (Ω)
- I_{OH} : Motor output current peak value (A)

The t2 and excitation frequency F values for each excitation mode are given by the following formulas.

1 phase excitation: $F = f \text{ clock}, t2 = \frac{1}{F} - (t1 + t3) \dots\dots\dots (14)$

2 phase excitation: $F = f \text{ clock}/2, t2 = \frac{1}{F} - (t1 + t3) \dots\dots\dots (15)$

1-2 phase excitation: $F = f \text{ clock}/3, t2 = \frac{1}{F} - t1 \dots\dots\dots (16)$

W1-2 phase excitation: $F = f \text{ clock}/7, t2 = \frac{1}{F} - t1 \dots\dots\dots (17)$

<Junction Temperature>

The junction temperature T_j for each device can be derived from the power dissipation P_{ds} for each transistor and θ_{j-c} .

$$T_j = T_c + \theta_{j-c} \times P_{ds} \text{ [}^\circ\text{C]} \dots\dots\dots (18)$$

The average power dissipation per transistor P_{ds} can be derived by referring to the P_d calculation formula (average power dissipation: the total for four transistors) for each excitation mode.

Example: The power dissipation per transistor can be calculated as $P_{ds} = P_d/4$.

Note that the thermal resistance of the power transistors has the following value.

θ_{j-c} for F1 to F4 = 13.5 $^\circ\text{C/W}$

Note: When calculating the T_j for the power transistors, the power dissipation in the detection resistor is included in the P_{ds} value. Therefore the voltage drop for the R_s must be taken into account in the calculation.

Fig. 17 $I_O - V_{st}$ characteristics

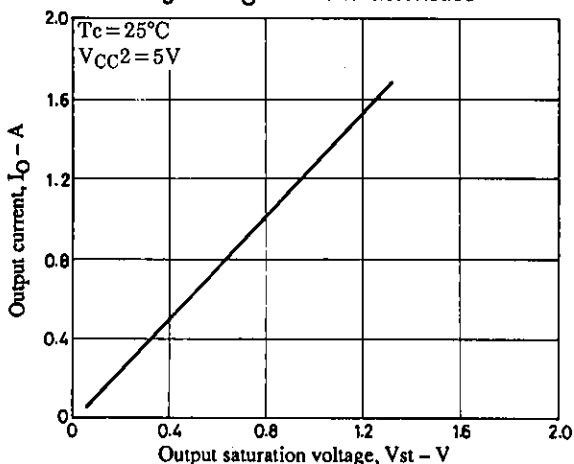
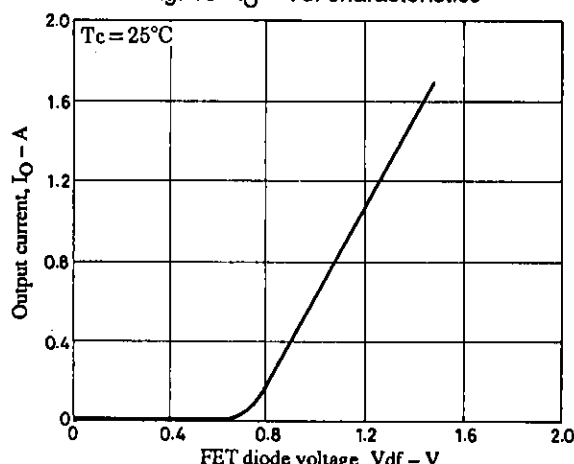

Fig. 18 $I_O - V_{df}$ characteristics



<STK672-010 No Heat Sink Region Example>

This section presents a case where the STK672-010 can be used without a heat sink.

Conditions:

- Motor power supply voltage $V_{CC} = 42 \text{ V}$, stepping motor electrical characteristics: 3.5 mH/ϕ , 3.5 Ω/ϕ
- Excitation: 2 phase excitation
- Input clock: 500 Hz (fixed)
- Hybrid IC ambient temperature $T_a = 25^\circ\text{C}$, natural convection
- Motor output current: 1.7 A

From these conditions and formulas (12), (13), and (15):

$$\begin{aligned} t_1 &\approx 0.15 \text{ ms} \\ t_2 &\approx 3.72 \text{ ms} \\ t_3 &\approx 0.13 \text{ ms} \end{aligned}$$

The average power dissipation is calculated from formula (9) referencing Figure 17 and Figure 18.

$$\begin{aligned} P_{d_{2EX}} &= (V_{st} + V_{df}) \frac{f_{\text{clock}}}{2} I_{OH} \cdot t_2 + \frac{I_{OH} \cdot f_{\text{clock}}}{2} (V_{st} \cdot t_1 + V_{df} \cdot t_3) \\ &\approx 4.43 + 0.16 \approx 4.6 \text{ [W]} \end{aligned}$$

T_c is derived from formula (7) as follows:

$$\begin{aligned} T_c &= P_{d_{2EX}} \times \theta_{c-a} + T_a = 4.6 \times 16.5 + 25 \approx 101 \text{ [}^\circ\text{C]} < T_c \text{ max} = 105 \text{ [}^\circ\text{C]} \\ &(\theta_{c-a} = 16.5^\circ\text{C/W: the thermal resistance of the hybrid IC itself with no heat sink)} \end{aligned}$$

Note that the typical values of the device characteristics have been used in this example. Therefore, due also to the details of the air flow around the hybrid IC, the actual values will not necessarily agree with this calculation, and must be confirmed in an actual operating circuit.

Fig. 19 $I_{OH} - V_{CC1}$ characteristics

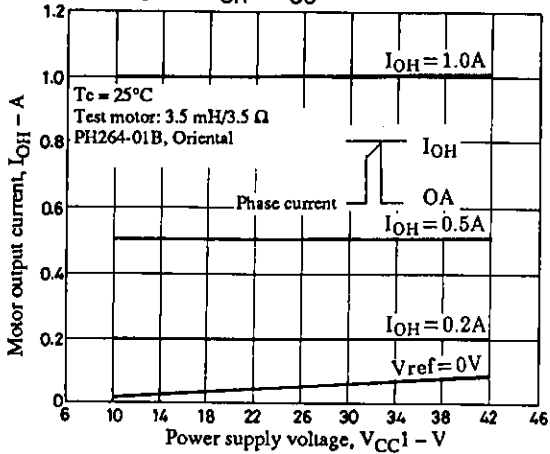

Fig. 20 $I_{OH} - T_c$ characteristics

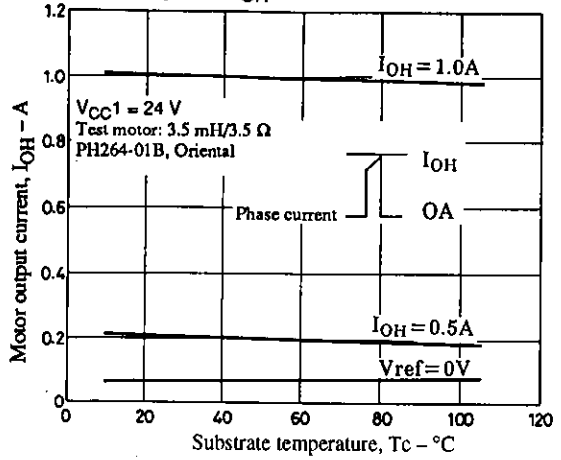

Fig. 21 $I_{DD} - V_{CC1}$ characteristics

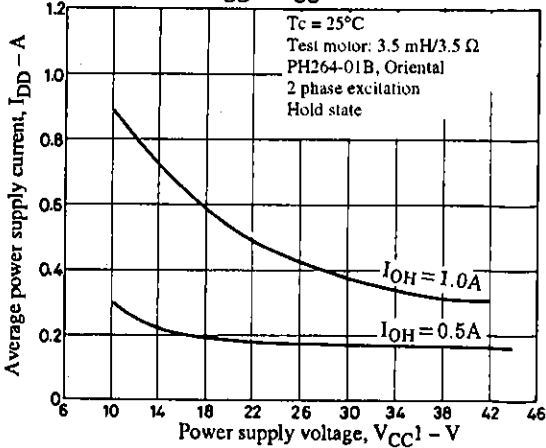

Fig. 22 $f_c - T_c$ characteristics

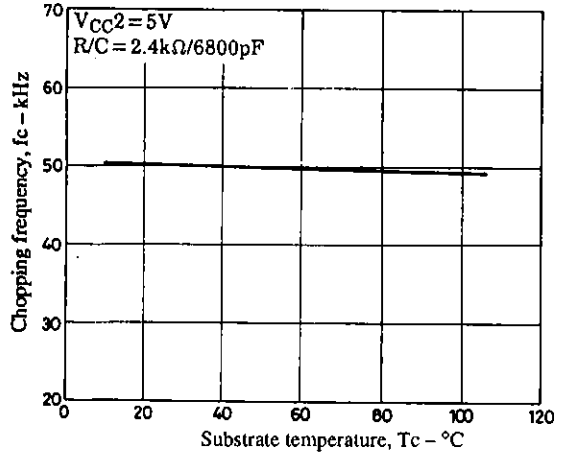

Fig. 23 $f_c - V_{CC2}$ characteristics

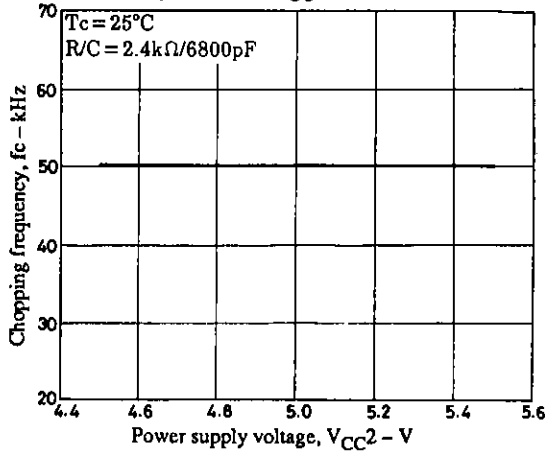

Fig. 24 $f_c - C1$ characteristics

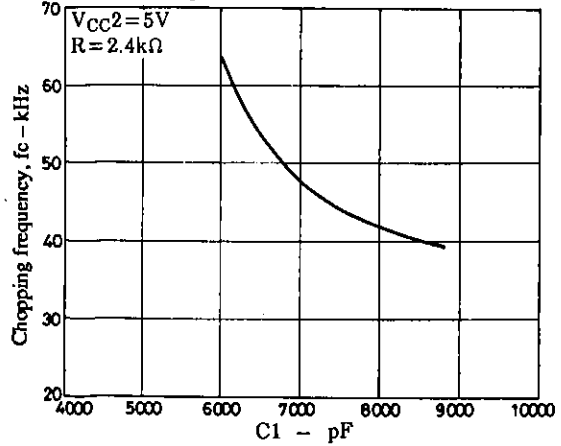

Fig. 25 $\Delta T_c -$ Input pulse characteristics

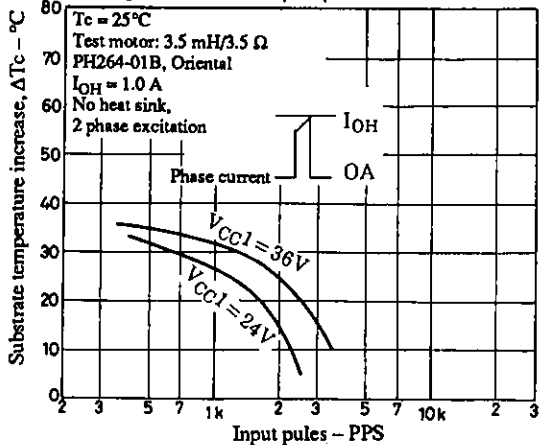
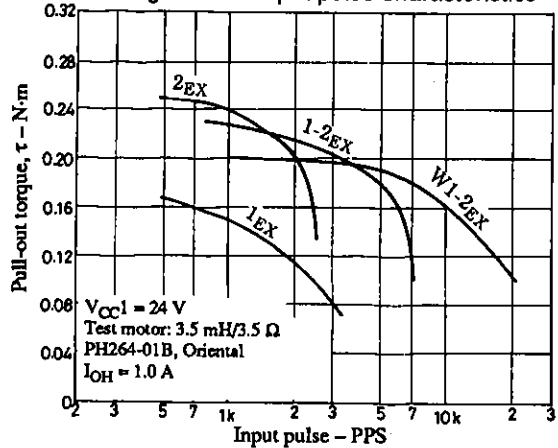

Fig. 26 $\tau -$ Input pulse characteristics



- No products described or contained herein are intended for use in surgical implants, life-support systems, aerospace equipment, nuclear power control systems, vehicles, disaster/crime-prevention equipment and the like, the failure of which may directly or indirectly cause injury, death or property loss.
- Anyone purchasing any products described or contained herein for an above-mentioned use shall:
 - ① Accept full responsibility and indemnify and defend SANYO ELECTRIC CO., LTD., its affiliates, subsidiaries and distributors and all their officers and employees, jointly and severally, against any and all claims and litigation and all damages, cost and expenses associated with such use:
 - ② Not impose any responsibility for any fault or negligence which may be cited in any such claim or litigation on SANYO ELECTRIC CO., LTD., its affiliates, subsidiaries and distributors or any of their officers and employees jointly or severally.
- Information (including circuit diagrams and circuit parameters) herein is for example only; it is not guaranteed for volume production. SANYO believes information herein is accurate and reliable, but no guarantees are made or implied regarding its use or any infringements of intellectual property rights or other rights of third parties.