



LC3564RM,RT-10LV/12LV/15LV

64K (8192 words × 8 bits) SRAM

Overview

The LC3564RM,RT are 8192-word × 8bit, asynchronous, silicon gate, low-voltage CMOS SRAM LSIs. They operate from a 2.0 to 3.6V supply, making them ideal for hand-held, battery-operated equipment.

They are fully CMOS devices employing 2-layer A1 wiring to realize high-speed access, low operating current consumption and very low standby current. They incorporate control signal inputs; \overline{OE} for high-speed memory access, and 2 chip enables $\overline{CE1}$ and CE2 for power-down and device selection.

They are ideal for systems requiring high speed, low power and battery backup or for easy memory expansion. The very low standby current means that backup can also be achieved using a capacitor.

Features

- Supply voltage range: 2.0 to 3.6V
 - 3V operation: 2.7 to 3.6V
 - Battery operation: 2.0 to 2.4V
- High-speed access time
 - 3V operation
 - LC3564RM,RT-10LV: 100ns (max)
 - LC3564RM,RT-12LV: 120ns (max)
 - LC3564RM,RT-15LV: 150ns (max)
 - Battery operation
 - LC3564RM,RT-10LV: 200ns (max)
 - LC3564RM,RT-12LV: 250ns (max)
 - LC3564RM,RT-15LV: 300ns (max)
- Very-low standby current
 - 3V operation
 - $T_a \leq 70^\circ\text{C}$: $1.0\mu\text{A}$
 - $T_a \leq 85^\circ\text{C}$: $3.0\mu\text{A}$
 - Battery operation
 - $T_a \leq 70^\circ\text{C}$: $0.85\mu\text{A}$
 - $T_a \leq 85^\circ\text{C}$: $2.5\mu\text{A}$
- Operating temperature range: -40 to $+85^\circ\text{C}$
- Data retention supply voltage: 2.0 to 3.6V
- Input/output levels: CMOS Compatible ($0.8V_{CC}/0.2V_{CC}$)
- 3 control inputs (\overline{OE} , $\overline{CE1}$, CE2)

- Common-pin input/outputs, 3-state output
- Clock not needed (fully-static RAM)
- Package
 - SOP 28-pin (450mil) plastic package: LC3564RM series
 - TSOP 28-pin ($8 \times 13.4\text{mm}$) plastic package: LC3564RT series

Package Dimensions

unit: mm

3158 - SOP28

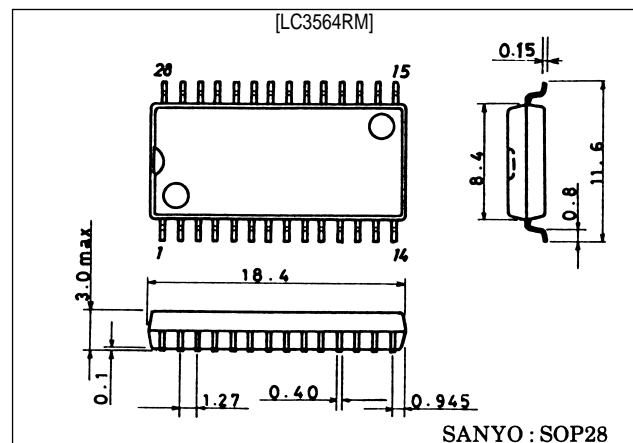

unit: mm

3221 - TSOP28

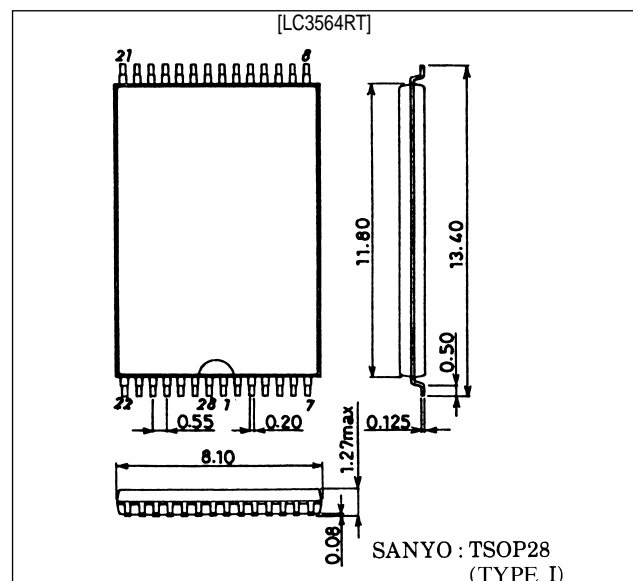

SANYO Electric Co., Ltd. Semiconductor Business Headquarters

TOKYO OFFICE Tokyo Bldg., 1-10, 1 Chome, Ueno, Taito-ku, TOKYO, 110 JAPAN

Pin Assignment

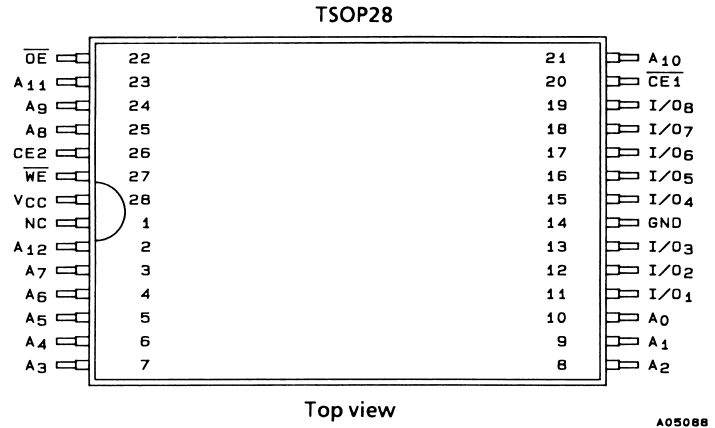
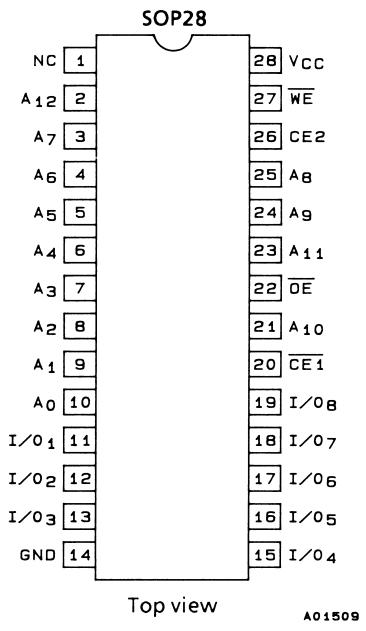

Block Diagram

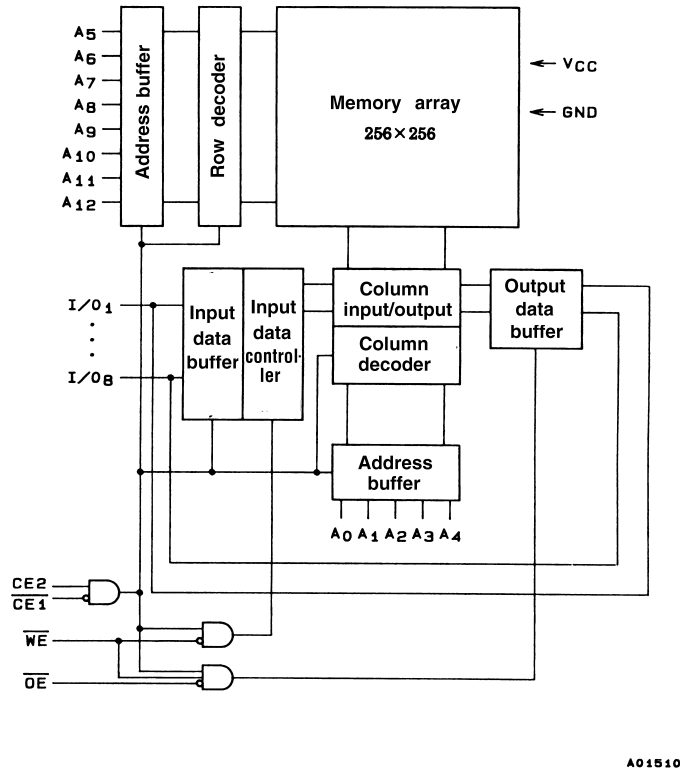

Pin Functions

Number	Name	Function
1	NC	No connection
2 to 10, 21, 23 to 25	A0 to A12	Address inputs
27	\overline{WE}	Read/write control input
22	\overline{OE}	Output enable input
20, 26	$\overline{CE1}$, CE2	Chip enable inputs
11 to 13, 15 to 19	I/O1 to I/O8	Data input/outputs
28, 14	V_{CC} , GND	Supply and ground pins

Truth Table

Mode	$\overline{CE1}$	CE2	\overline{OE}	$\overline{WE1}$	I/O	Supply current
Read cycle	L	H	L	H	Data output	I_{CCA}
Write cycle	L	H	X	L	Data input	I_{CCA}
Output disable	L	H	H	H	High impedance	I_{CCA}
No selection	H	X	X	X	High impedance	I_{CCS}
	X	L	X	X	High impedance	I_{CCS}

Note: X = H or L

Specifications

Absolute Maximum Ratings at $T_a = 25^\circ\text{C}$

Parameter	Symbol	Conditions	Ratings	Unit
Maximum supply voltage	$V_{CC,max}$		4.6	V
Input voltage range	V_{IN}		-0.3 to $V_{CC} + 0.3$	V
Input/output voltage range	$V_{I/O}$		-0.3 to $V_{CC} + 0.3$	V
Operating temperature range	T_{opr}		-40 to +85	$^\circ\text{C}$
Storage temperature range	T_{stg}		-55 to +125	$^\circ\text{C}$

Note: Permanent device damage may occur if Absolute Maximum Ratings are exceeded. Functional operation should be restricted to Recommended operating conditions. Exposure to higher than recommended voltages for extended periods of time could affect device reliability.

Inout/Output Capacitance at $T_a = 25^\circ\text{C}$, $f = 1\text{ MHz}$

Parameter	Symbol	Conditions	Ratings			Unit
			min.	typ.	max.	
Input/output pin capacitance	$C_{I/O}$	$V_{I/O} = 0\text{V}$	-	6	10	pF
Input pin capacitance	C_I	$V_I = 0\text{V}$	-	6	10	pF

Note: Measured samples only.

3V Operation

DC Recommended Operating Ranges at $T_a = -40$ to $+85^\circ\text{C}$, $V_{CC} = 2.7$ to 3.6V

Parameter	Symbol	Ratings			Unit
		min.	typ.	max.	
Supply voltage	V_{CC}	2.7	3.0	3.6	V
Input voltage	V_{IH}	$0.8V_{CC}$	-	$V_{CC} + 0.3$	V
	V_{IL}	-0.3^*	-	$0.2V_{CC}$	V

* When pulsewidth is less than 30 ns, the minimum value is -2.0V.

DC Electrical Characteristics at $T_a = -40$ to $+85^\circ\text{C}$, $V_{CC} = 2.7$ to 3.6V

Parameter	Symbol	Conditions	Ratings			Unit			
			min.	typ.*	max.				
Input leakage current	I_{LI}	$V_{IN} = 0\text{V to } V_{CC}$	-1.0	-	+1.0	μA			
I/O leakage current	I_{LO}	$V_{CE1} = V_{IH}$ or $V_{CE2} = V_{IL}$ or $V_{OE} = V_{IH}$ or $V_{WE} = V_{IL}$, $V_{IO} = 0\text{V to } V_{CC}$	-1.0	-	+1.0	μA			
Output high level voltage	V_{OH}	$I_{OH} = -2.0\text{mA}$	$V_{CC} - 0.4$	-	-	V			
Output low level voltage	V_{OL}	$I_{OL} = 2.0\text{mA}$	-	-	0.4	V			
Operating supply current	$V_{CC} - 0.2\text{V}/0.2\text{V}$ input	I_{CCA1}	$V_{CE1} \leq 0.2\text{V}$, $V_{CE2} \geq V_{CC} - 0.2\text{V}$, $I_{IO} = 0\text{mA}$, $V_{IN} \leq 0.2\text{V}$ or $V_{IN} \geq V_{CC} - 0.2\text{V}$	$T_a \leq 70^\circ\text{C}$	-	0.01	1.0	μA	
				$T_a \leq 85^\circ\text{C}$	-	-	3.0	μA	
	CMOS input	I_{CCA2}	$V_{CE1} = V_{IL}$, $V_{CE2} = V_{IH}$, $I_{IO} = 0\text{mA}$, duty = 100%	$V_{CE1} = V_{IL}$, $V_{CE2} = V_{IH}$, $I_{IO} = 0\text{mA}$, $V_{IN} = V_{IH}$ or V_{IL}		-	-	4	mA
				min. cycle	-	-	25	mA	
				200 ns cycle	-	-	15	mA	
1 μs cycle	-	-	10	mA					
Standby supply current	$V_{CC} - 0.2\text{V}/0.2\text{V}$ input	I_{CCS1}	$V_{CE2} \leq 0.2\text{V}$ or { $V_{CE1} \geq V_{CC} - 0.2\text{V}$, $V_{CE2} \geq V_{CC} - 0.2\text{V}$ }	$T_a \leq 70^\circ\text{C}$	-	0.01	1.0	μA	
				$T_a \leq 85^\circ\text{C}$	-	-	3.0	μA	
	CMOS input	I_{CCS2}	$V_{CE2} = V_{IL}$ or $V_{CE1} = V_{IH}$, $V_{IN} = 0\text{V to } V_{CC}$		-	-	1	mA	

* $V_{CC} = 3.0\text{V}$, $T_a = 25^\circ\text{C}$

LC3564RM,RT-10LV/12LV/15LV

AC Electrical Characteristics at $T_a = -40$ to $+85^\circ\text{C}$, $V_{CC} = 2.7$ to 3.6V

AC test conditions

Input pulse voltage level: $0.2V_{CC}$ to $0.8V_{CC}$

Input rise and fall times: 5 ns

Input/output timing level: $V_{CC}/2$

Output load: 30 pF (including jig capacitance)

Read Cycle

Parameter	Symbol	LC3564RM,RT						Unit
		-10LV		-12LV		-15LV		
		min.	max.	min.	max.	min.	max.	
Read cycle time	t_{RC}	100	-	120	-	150	-	ns
Address access time	t_{AA}	-	100	-	120	-	150	ns
CE1 access time	t_{CA1}	-	100	-	120	-	150	ns
CE2 access time	t_{CA2}	-	100	-	120	-	150	ns
OE access time	t_{OA}	-	50	-	60	-	75	ns
Output hold time	t_{OH}	10	-	10	-	10	-	ns
CE1 output enable time	t_{COE1}	10	-	10	-	10	-	ns
CE2 output enable time	t_{COE2}	10	-	10	-	10	-	ns
OE output enable time	t_{OOE}	5	-	5	-	5	-	ns
CE1 output disable time	t_{COD1}	-	35	-	40	-	50	ns
CE2 output disable time	t_{COD2}	-	35	-	40	-	50	ns
OE output disable time	t_{OOD}	-	25	-	30	-	40	ns

Write Cycle

Parameter	Symbol	LC3564RM,RT						Unit
		-10LV		-12LV		-15LV		
		min.	max.	min.	max.	min.	max.	
Write cycle time	t_{WC}	100	-	120	-	150	-	ns
Address setup time	t_{AS}	0	-	0	-	0	-	ns
Write pulsewidth	t_{WP}	60	-	70	-	80	-	ns
CE1 setup time	t_{CW1}	70	-	80	-	90	-	ns
CE2 setup time	t_{CW2}	70	-	80	-	90	-	ns
Write recovery time	t_{WR}	0	-	0	-	0	-	ns
CE1 write recovery time	t_{WR1}	0	-	0	-	0	-	ns
CE2 write recovery time	t_{WR2}	0	-	0	-	0	-	ns
Data setup time	t_{DS}	50	-	55	-	60	-	ns
Data hold time	t_{DH}	0	-	0	-	0	-	ns
CE1 data hold time	t_{DH1}	0	-	0	-	0	-	ns
CE2 data hold time	t_{DH2}	0	-	0	-	0	-	ns
WE output enable time	t_{WOE}	5	-	5	-	5	-	ns
WE output disable time	t_{WOD}	-	35	-	40	-	45	ns

Battery Operation

DC Recommended Operating Ranges at $T_a = -40$ to $+85^\circ\text{C}$, $V_{CC} = 2.0$ to 2.4V

Parameter	Symbol	Ratings			Unit
		min.	typ.	max.	
Supply voltage	V_{CC}	2.0	2.2	2.4	V
Input voltage	V_{IH}	$0.8V_{CC}$	-	$V_{CC} + 0.3$	V
	V_{IL}	-0.3	-	$0.2V_{CC}$	V

DC Electrical Characteristics at $T_a = -40$ to $+85^\circ\text{C}$, $V_{CC} = 2.0$ to 2.4V

Parameter	Symbol	Conditions	Ratings			Unit		
			min.	typ.*	max.			
Input leakage current	I_{LI}	$V_{IN} = 0\text{V to } V_{CC}$	-1.0	-	+1.0	μA		
I/O leakage current	I_{LO}	$V_{CE1} = V_{IH}$ or $V_{CE2} = V_{IL}$ or $V_{OE} = V_{IH}$ or $V_{WE} = V_{IL}$, $V_{IO} = 0\text{V to } V_{CC}$	-1.0	-	+1.0	μA		
Output high level voltage	V_{OH}	$I_{OH} = -0.5\text{mA}$	$V_{CC} - 0.2$	-	-	V		
Output low level voltage	V_{OL}	$I_{OL} = 0.5\text{mA}$	-	-	0.2	V		
Operating supply current	$V_{CC} - 0.2\text{V}/0.2\text{V}$ input	I_{CCA1}	$V_{CE1} \leq 0.2\text{V}$, $V_{CE2} \geq V_{CC} - 0.2\text{V}$, $I_{IO} = 0\text{mA}$, $V_{IN} \leq 0.2\text{V}$ or $V_{IN} \geq V_{CC} - 0.2\text{V}$	$T_a \leq 70^\circ\text{C}$	-	0.01	0.85	μA
				$T_a \leq 85^\circ\text{C}$	-	-	2.5	μA
	CMOS input	I_{CCA2}	$V_{CE1} = V_{IL}$, $V_{CE2} = V_{IH}$, $I_{IO} = 0\text{mA}$, $V_{IN} = V_{IH}$ or V_{IL}		-	-	2	mA
		I_{CCA3}	$V_{CE1} = V_{IL}$, $V_{CE2} = V_{IH}$, $I_{IO} = 0\text{mA}$, duty = 100%	min. cycle	-	-	10	mA
			1 μs cycle	-	-	5	mA	
Standby supply current	$V_{CC} - 0.2\text{V}/0.2\text{V}$ input	I_{CCS1}	$V_{CE2} \leq 0.2\text{V}$ or { $V_{CE1} \geq V_{CC} - 0.2\text{V}$, $V_{CE2} \geq V_{CC} - 0.2\text{V}$ }	$T_a \leq 70^\circ\text{C}$	-	0.01	0.85	μA
				$T_a \leq 85^\circ\text{C}$	-	-	2.5	μA
	CMOS input	I_{CCS2}	$V_{CE2} = V_{IL}$ or $V_{CE1} = V_{IH}$, $V_{IN} = 0\text{V to } V_{CC}$		-	-	800	mA

* $V_{CC} = 2.2\text{V}$, $T_a = 25^\circ\text{C}$

LC3564RM,RT-10LV/12LV/15LV

AC Electrical Characteristics at $T_a = -40$ to $+85^\circ\text{C}$, $V_{CC} = 2.0$ to 2.4V

AC test conditions

Input pulse voltage level: $0.2V_{CC}$ to $0.8V_{CC}$

Input rise and fall times: 10 ns

Input/output timing level: $V_{CC}/2$

Output load: 30 pF (including jig capacitance)

Read Cycle

Parameter	Symbol	LC3564RM,RT						Unit
		-10LV		-12LV		-15LV		
		min.	max.	min.	max.	min.	max.	
Read cycle time	t_{RC}	200	-	250	-	300	-	ns
Address access time	t_{AA}	-	200	-	250	-	300	ns
$\overline{\text{CE}}1$ access time	t_{CA1}	-	200	-	250	-	300	ns
CE2 access time	t_{CA2}	-	200	-	250	-	300	ns
$\overline{\text{OE}}$ access time	t_{OA}	-	120	-	130	-	150	ns
Output hold time	t_{OH}	10	-	10	-	10	-	ns
$\overline{\text{CE}}1$ output enable time	t_{COE1}	10	-	10	-	10	-	ns
CE2 output enable time	t_{COE2}	10	-	10	-	10	-	ns
$\overline{\text{OE}}$ output enable time	t_{OOE}	5	-	5	-	5	-	ns
$\overline{\text{CE}}1$ output disable time	t_{COD1}	-	70	-	80	-	100	ns
CE2 output disable time	t_{COD2}	-	70	-	80	-	100	ns
$\overline{\text{OE}}$ output disable time	t_{OOD}	-	50	-	60	-	80	ns

Write Cycle

Parameter	Symbol	LC3564RM,RT						Unit
		-10LV		-12LV		-15LV		
		min.	max.	min.	max.	min.	max.	
Write cycle time	t_{WC}	200	-	250	-	300	-	ns
Address setup time	t_{AS}	0	-	0	-	0	-	ns
Write pulsewidth	t_{WP}	120	-	140	-	160	-	ns
$\overline{\text{CE}}1$ setup time	t_{CW1}	140	-	160	-	180	-	ns
CE2 setup time	t_{CW2}	140	-	160	-	180	-	ns
Write recovery time	t_{WR}	0	-	0	-	0	-	ns
$\overline{\text{CE}}1$ write recovery time	t_{WR1}	0	-	0	-	0	-	ns
CE2 write recovery time	t_{WR2}	0	-	0	-	0	-	ns
Data setup time	t_{DS}	120	-	130	-	150	-	ns
Data hold time	t_{DH}	0	-	0	-	0	-	ns
$\overline{\text{CE}}1$ data hold time	t_{DH1}	0	-	0	-	0	-	ns
CE2 data hold time	t_{DH2}	0	-	0	-	0	-	ns
WE output enable time	t_{WOE}	5	-	5	-	5	-	ns
WE output disable time	t_{WOD}	-	70	-	80	-	90	ns

Timing Chart

Read Cycle: Note 1

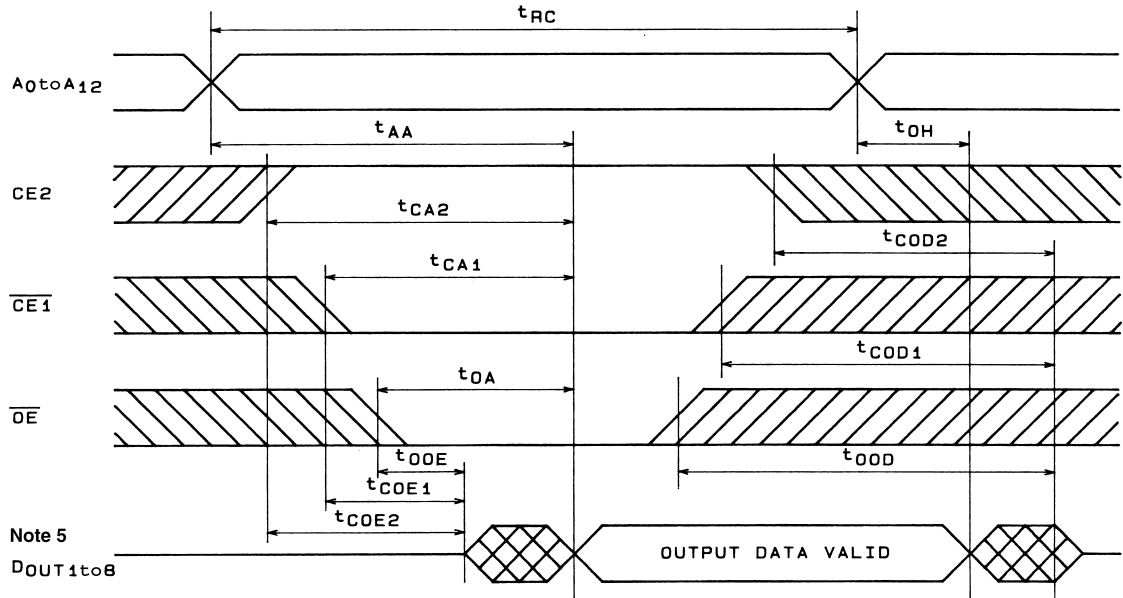

A01511

Write Cycle 1 (\overline{WE} write): Note 6

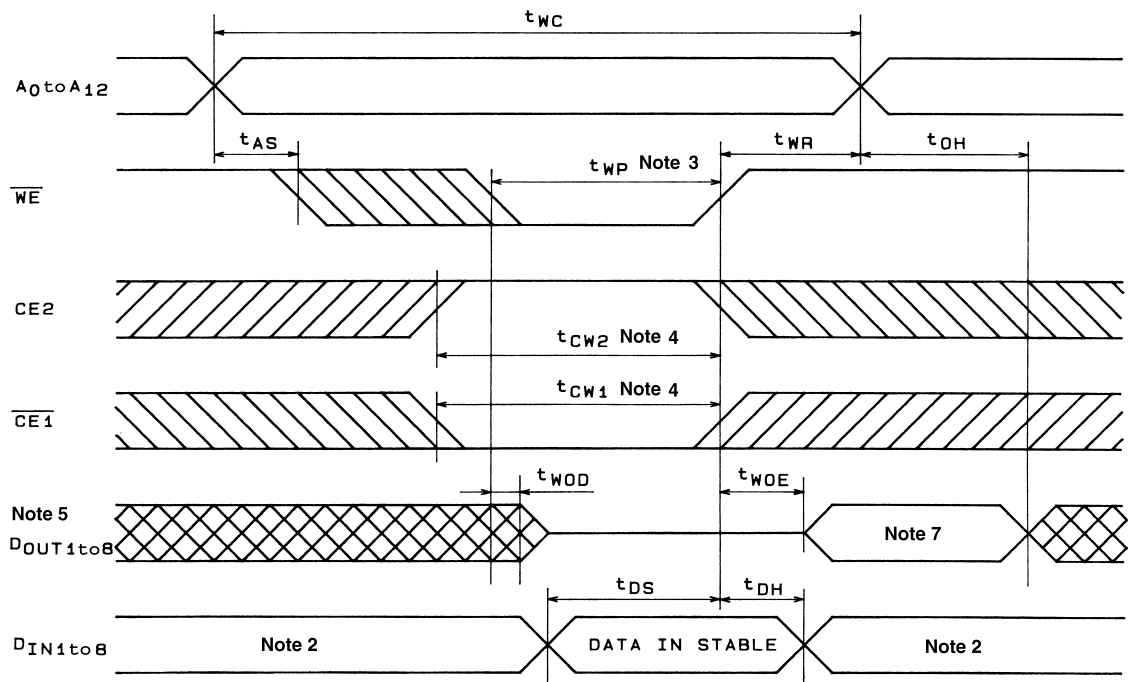

A01512

Write Cycle 2 ($\overline{CE1}$ write): Note 6

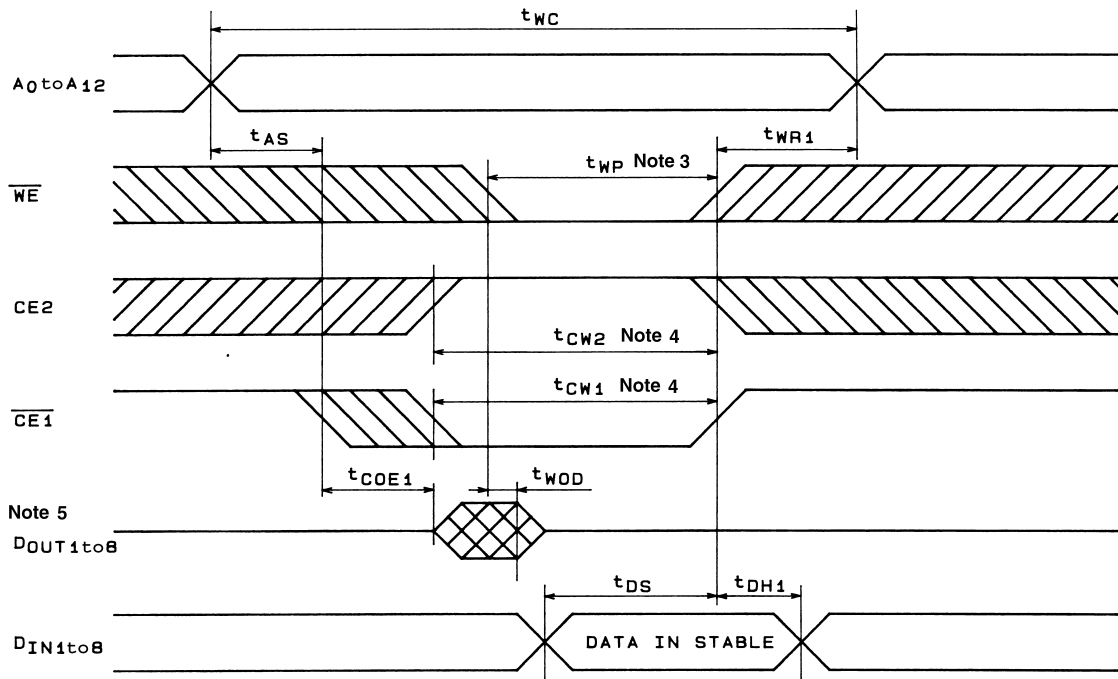

A01513

Write Cycle 3 (CE2 write): Note 6

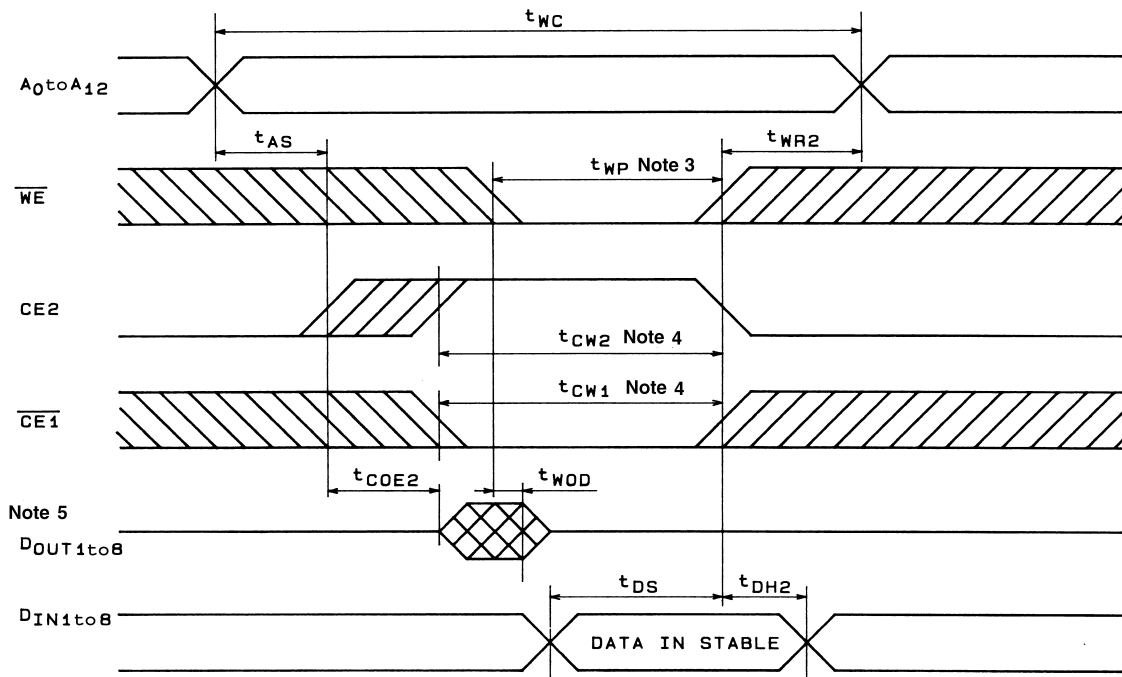

A01514

- Note: 1. We should be held high level during the read cycle
 2. Do not apply external signals that are out-of-phase with D_{OUT}
 3. t_{WP} is a period when $\overline{CE1}$ and \overline{WE} are LOW and CE2 is HIGH. It is measured from when \overline{WE} goes low level to when either $\overline{CE1}$ and \overline{WE} go HIGH or CE2 goes LOW, whichever occurs first.
 4. t_{CW1} and t_{CW2} are periods when $\overline{CE1}$ and \overline{WE} are LOW and CE2 is HIGH. They are measured from when $\overline{CE1}$ goes LOW and CE2 goes HIGH, respectively, to when either $\overline{CE1}$ and \overline{WE} go HIGH or CE2 goes LOW, whichever occurs first.
 5. The outputs D_{OUT1} to D_{OUT8} are in a high-impedance state when \overline{OE} is HIGH, $\overline{CE1}$ is HIGH, CE2 is LOW and \overline{WE} is LOW.
 6. During the write cycle, \overline{OE} is V_{IH} or V_{IL} .
 7. D_{OUT} has the same phase as the write data.

Data Retention Characteristics at $T_a = -40$ to $+85^\circ\text{C}$

3V Operation

Parameter	Symbol	Conditions	Ratings			Unit
			min.	typ.	max.	
Data retention supply voltage	V_{DR}	$V_{CE1} \geq V_{CC} - 0.2V$, $V_{CE2} \geq V_{CC} - 0.2V$ or $V_{CE2} \leq 0.2V$	2.0	-	3.6	V
Chip enable setup time	t_{CDR}		0	-	-	ns
Chip enable hold time	t_R		t_{RC}	-	-	ns

Note: t_{RC} is the read cycle time.

Data Retention Waveform 1 (CE1 control)

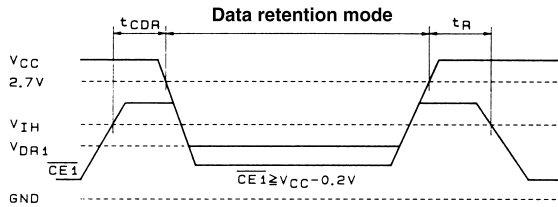

A01515

Data Retention Waveform 2 (CE2 control)

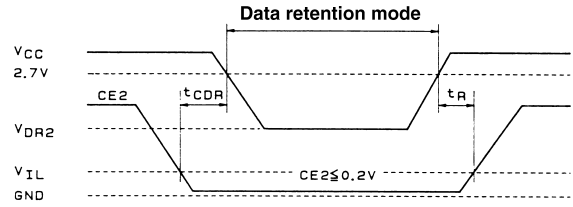

A01516

Battery Operation

Parameter	Symbol	Conditions	Ratings			Unit
			min.	typ.	max.	
Data retention supply voltage	V_{DR}	$V_{CE1} \geq V_{CC} - 0.2V$, $V_{CE2} \geq V_{CC} - 0.2V$ or $V_{CE2} \leq 0.2V$	2.0	-	3.6	V

- No products described or contained herein are intended for use in surgical implants, life-support systems, aerospace equipment, nuclear power control systems, vehicles, disaster/crime-prevention equipment and the like, the failure of which may directly or indirectly cause injury, death or property loss.
- Anyone purchasing any products described or contained herein for an above-mentioned use shall:
 - ① Accept full responsibility and indemnify and defend SANYO ELECTRIC CO., LTD., its affiliates, subsidiaries and distributors and all their officers and employees, jointly and severally, against any and all claims and litigation and all damages, cost and expenses associated with such use:
 - ② Not impose any responsibility for any fault or negligence which may be cited in any such claim or litigation on SANYO ELECTRIC CO., LTD., its affiliates, subsidiaries and distributors or any of their officers and employees, jointly or severally.
- Information (including circuit diagrams and circuit parameters) herein is for example only; it is not guaranteed for volume production. SANYO believes information herein is accurate and reliable, but no guarantees are made or implied regarding its use or any infringements of intellectual property rights or other rights of third parties.

This catalog provides information as of June, 1997. Specifications and information herein are subject to change without notice.