

**LA8608V**

## 1.8 V Low-Voltage Narrowband FM-IF System

### Overview

The LA8608V is a narrowband FM-IF system intended for communications equipment, operates at just 1.8 V, and is contained in an ultrasmall package with a 0.65 mm pitch. In addition to the various functions needed for reception, the LA8608V also offers other functions such as noise detection and electric field intensity detection, and is optimum for compact designs, such as for cordless phones.

### Functions

- 2nd mixer, 2nd local oscillator, IF amplifier, limiter, quadrature detector, signal meter
- Noise detector, noise amplifier, noise detector, Schmitt trigger, comparator

### Features

- Because this IC has three independent noise detection and amplification amplifiers, it can be used to form a secondary biquad bandpass filter; furthermore, because it is equipped with detector and Schmitt trigger functions, it can be easily used for carrier sense applications.
- Broad signal meter linearity (70 dB typ.)
- Low operating voltage: 1.8 V to 6 V
- Small package: SSOP-24 (0.65 mm pitch)

### Package Dimensions

unit : mm

#### 3175A-SSOP24

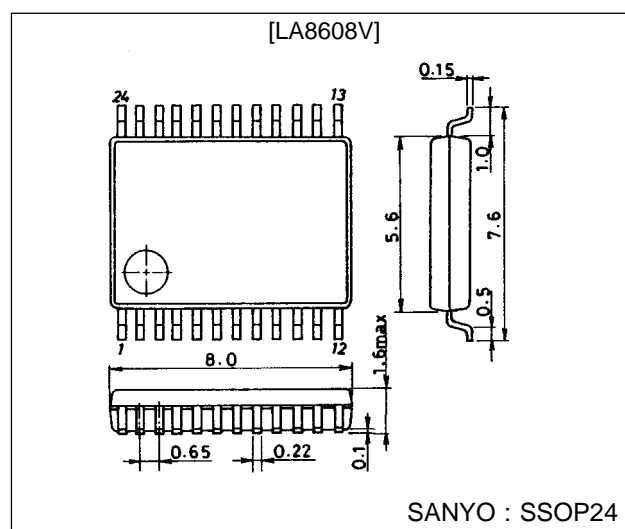

### Specifications

#### Maximum Ratings at Ta = 25 °C

Parameter	Symbol	Conditions	Ratings	Unit
Maximum supply voltage	V <sub>CCmax</sub>		8.0	V
Allowable power dissipation	P <sub>d max</sub>		300	mW
Operating temperature	T <sub>opr</sub>		-20 to +75	°C
Storage temperature	T <sub>stg</sub>		-40 to +125	°C

#### Operating Conditions at Ta = 25 °C

Parameter	Symbol	Conditions	Ratings	Unit
Recommended supply voltage	V <sub>CC</sub>		3.0	V
Operating supply voltage range	V <sub>CC op</sub>		1.8 to 6.0	V

## LA8608V

**Operating Characteristics at  $T_a = 25\text{ }^\circ\text{C}$ ,  $V_{CC} = 3\text{ V}$ ,  $f_c = 21.7\text{ MHz}$ ,  $f_{mod} = 1\text{ kHz}$ ,  $dev = \pm 3\text{ kHz}$**

Parameter	Symbol	Output	min	typ	max	Unit
Quiescent current	$I_{CCO}$	No input		2.8	3.8	mA
-3 dB limiting sensitivity	-3dBLS.	-3 dB		5	11	dB $\mu$
Demodulation output	$V_O$	$V_{in} = 80\text{ dB}\mu$	115	170	230	mVrms
S/N ratio	S/N(1)	$V_{in} = 80\text{ dB}\mu$ , Non-modulation	54	60		dB
	S/N(2)	$V_{in} = 20\text{ dB}\mu$ , Non-modulation	20	25		dB
AM rejection ratio	AMR	$V_{in} = 80\text{ dB}\mu$ , AM 30% modulation	30	40		dB
Total harmonic distortion	THD	$V_{in} = 80\text{ dB}\mu$		0.7	2.0	%
Noise detection output	$V_{ND}(1)$	$V_{in} = 10\text{ dB}\mu$ , $V_{CC} = 2.1\text{ V}$		1.9		V
	$V_{ND}(2)$	$V_{in} = 10\text{ dB}\mu$ , $V_{CC} = 3.0\text{ V}$	1.6	2.2	2.8	V
	$V_{ND}(3)$	$V_{in} = 10\text{ dB}\mu$ , $V_{CC} = 5.0\text{ V}$		2.3		V
	$V_{ND}(4)$	$V_{in} = 30\text{ dB}\mu$		0	0.1	V
Schmitt trigger level	SH		12	20	27	dB $\mu$
Schmitt hysteresis	SHhy			1		dB
Schmitt output level	$V_{SH}(1)$	$V_{in} = 13\text{ dB}\mu$			0.5	V
	$V_{SH}(2)$	$V_{in} = 26\text{ dB}\mu$	2.8			V
Signal meter output	$V_{SM}(1)$	$V_{in} = 5\text{ dB}\mu$		0.1	0.3	V
	$V_{SM}(2)$	$V_{in} = 50\text{ dB}\mu$	0.8	1.1	1.4	V
	$V_{SM}(3)$	$V_{in} = 80\text{ dB}\mu$	1.3	1.6	2.0	V
Comparator output	$V_{COMP}(1)$	$V_g = 1.5\text{ V}$	2.8			V
	$V_{COMP}(2)$	$V_g = 0.9\text{ V}$			0.5	V
Mixer conversion gain	$G_M$			20		dB
Mixer input frequency					90	MHz
Mixer input resistance				3.6		k $\Omega$
Mixer output resistance				1.8		k $\Omega$
IF input resistance				1.8		k $\Omega$
FM detection output impedance				2.4		k $\Omega$

# LA8608V

## Block Diagram and Pin Assignment

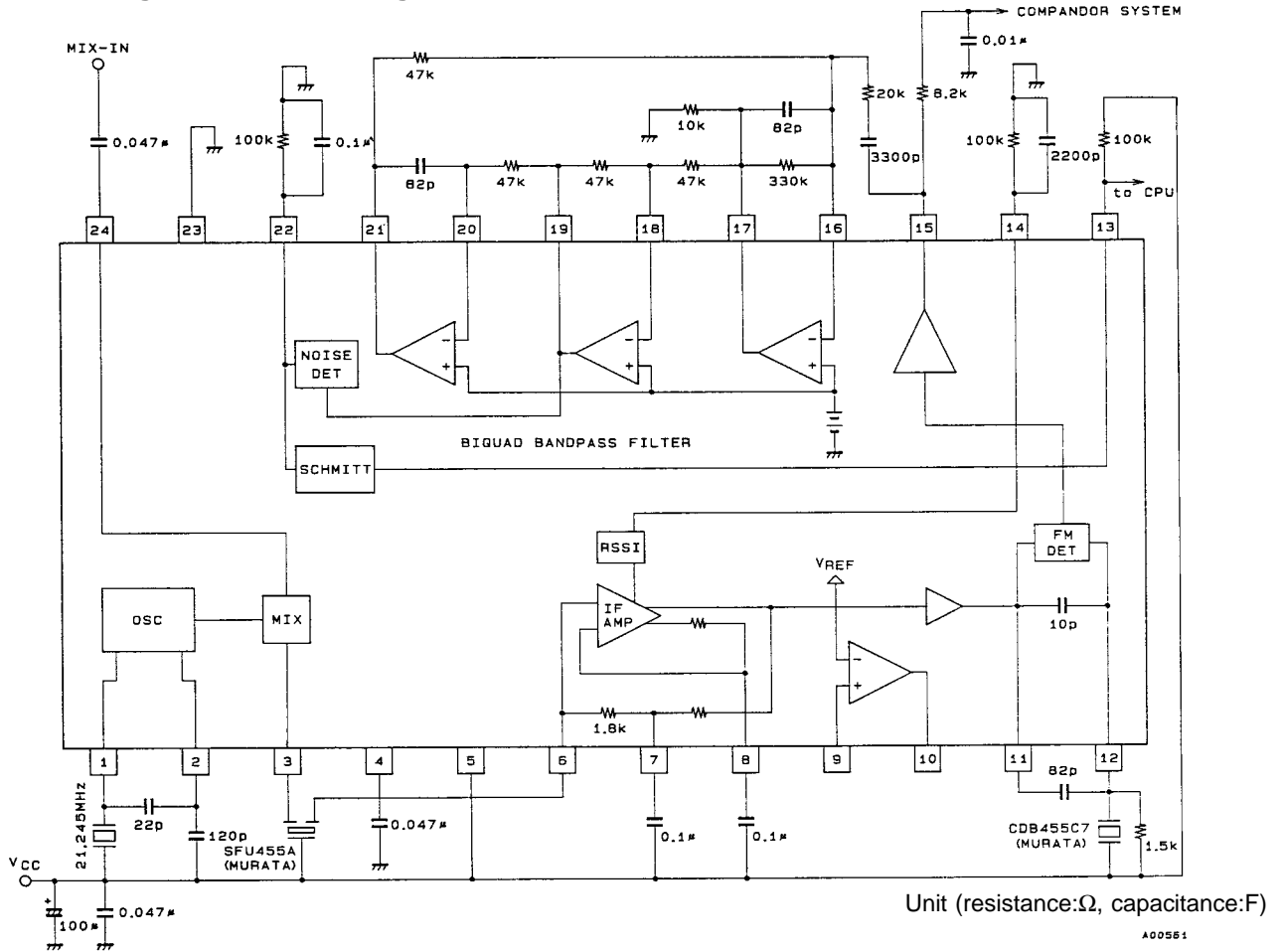

### Pins

- |                     |                 |                |
|---------------------|-----------------|----------------|
| 1. CRYSTAL          | 9. COMP(+)      | 17. OUT1       |
| 2. OSC              | 10. COMP-OUT    | 18. IN(-)2     |
| 3. MIX-OUT          | 11. LIMT.OUT    | 19. OUT2       |
| 4. V <sub>REF</sub> | 12. QUAD-COIL   | 20. IN(-)3     |
| 5. V <sub>CC</sub>  | 13. SCHMITT-OUT | 21. OUT3       |
| 6. IF-IN            | 14. S.DET.      | 22. NOISE-DET. |
| 7. D.C1             | 15. DET-OUT     | 23. GND        |
| 8. D.C2             | 16. IN(-)1      | 24. MIX-IN     |

# LA8608V

## AC Test Circuit

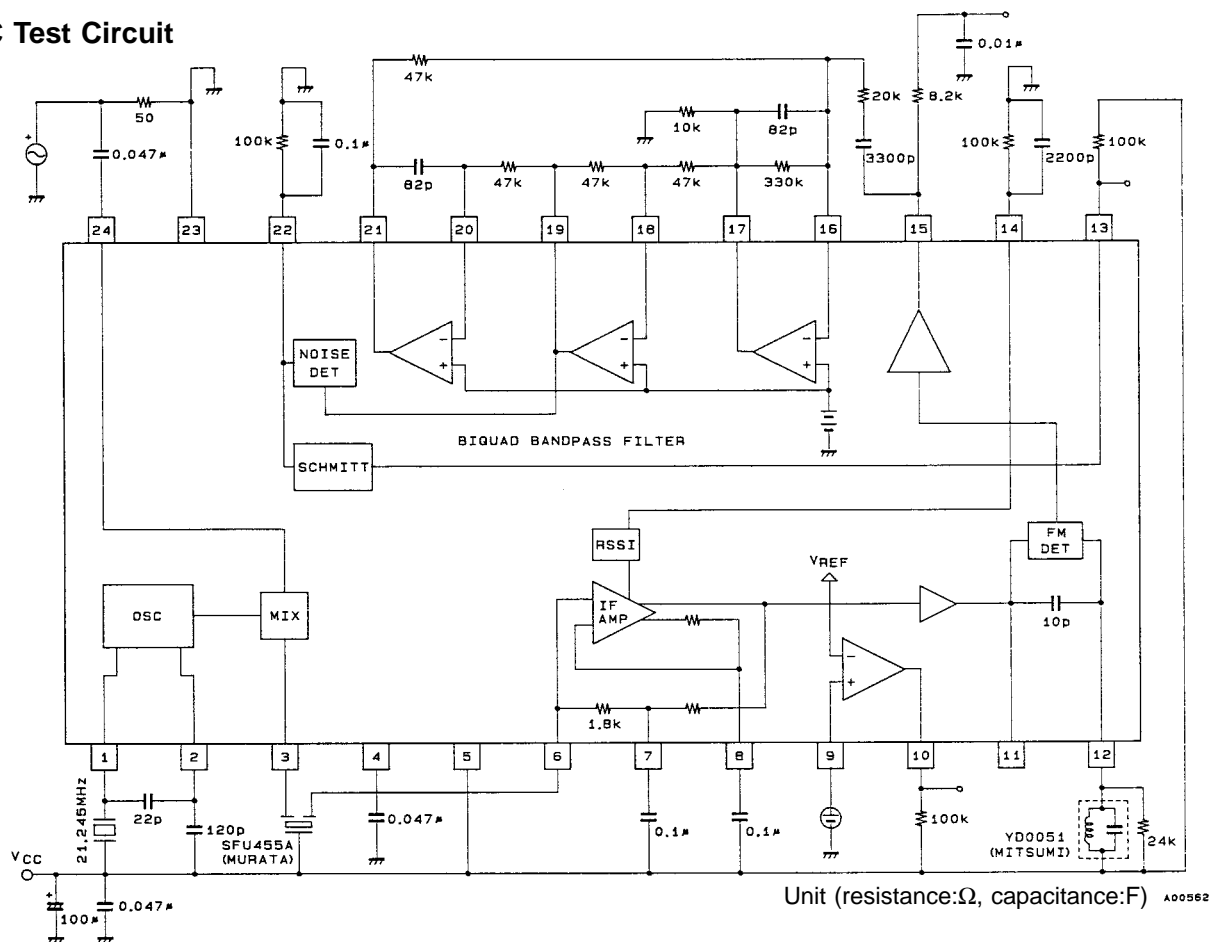

## Sample Application Circuit (1)

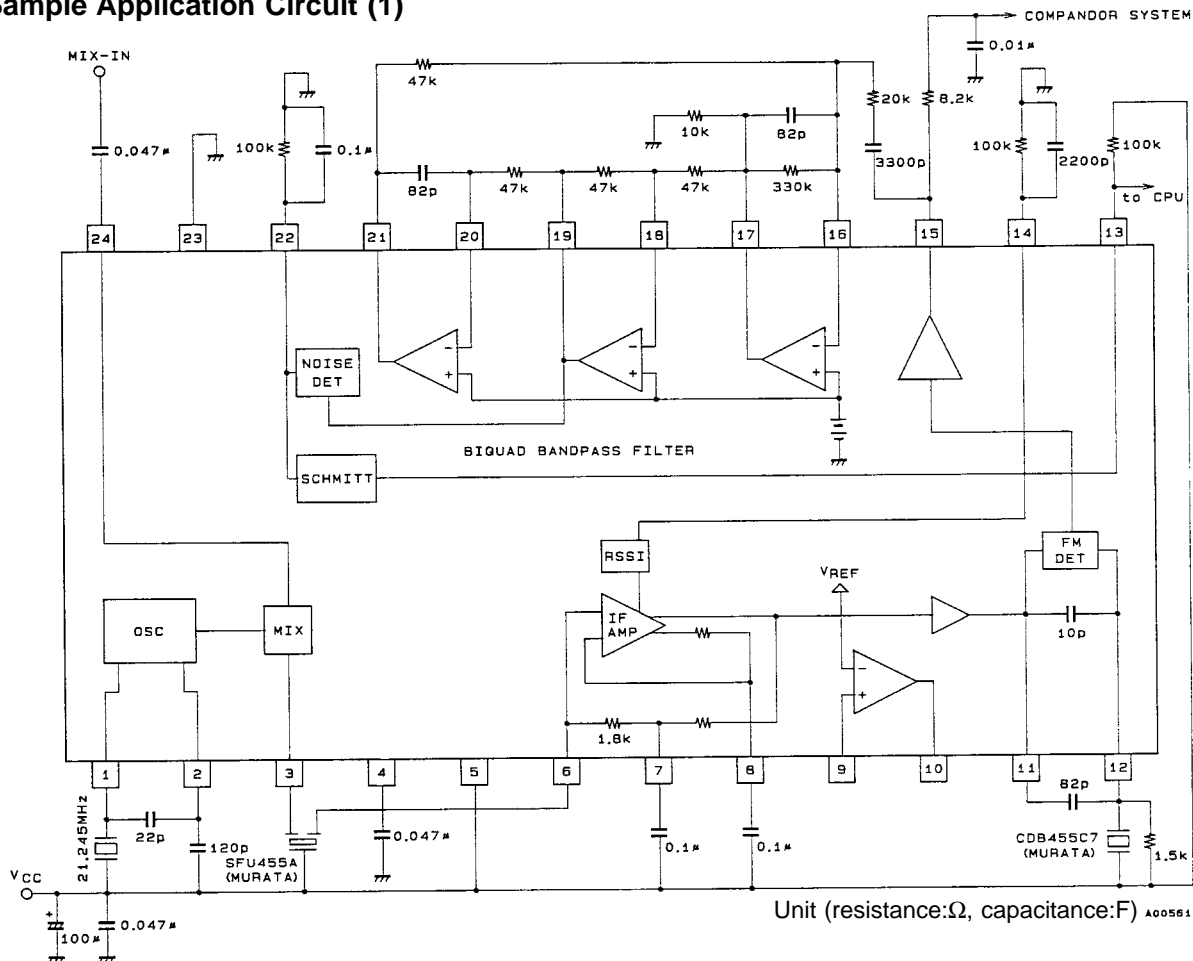

Sample Application Circuit (2)

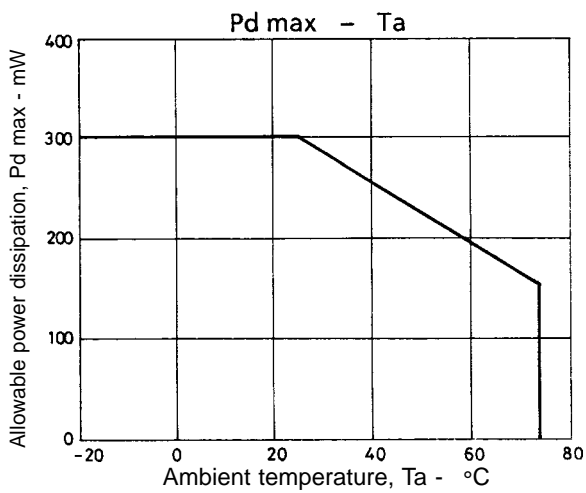
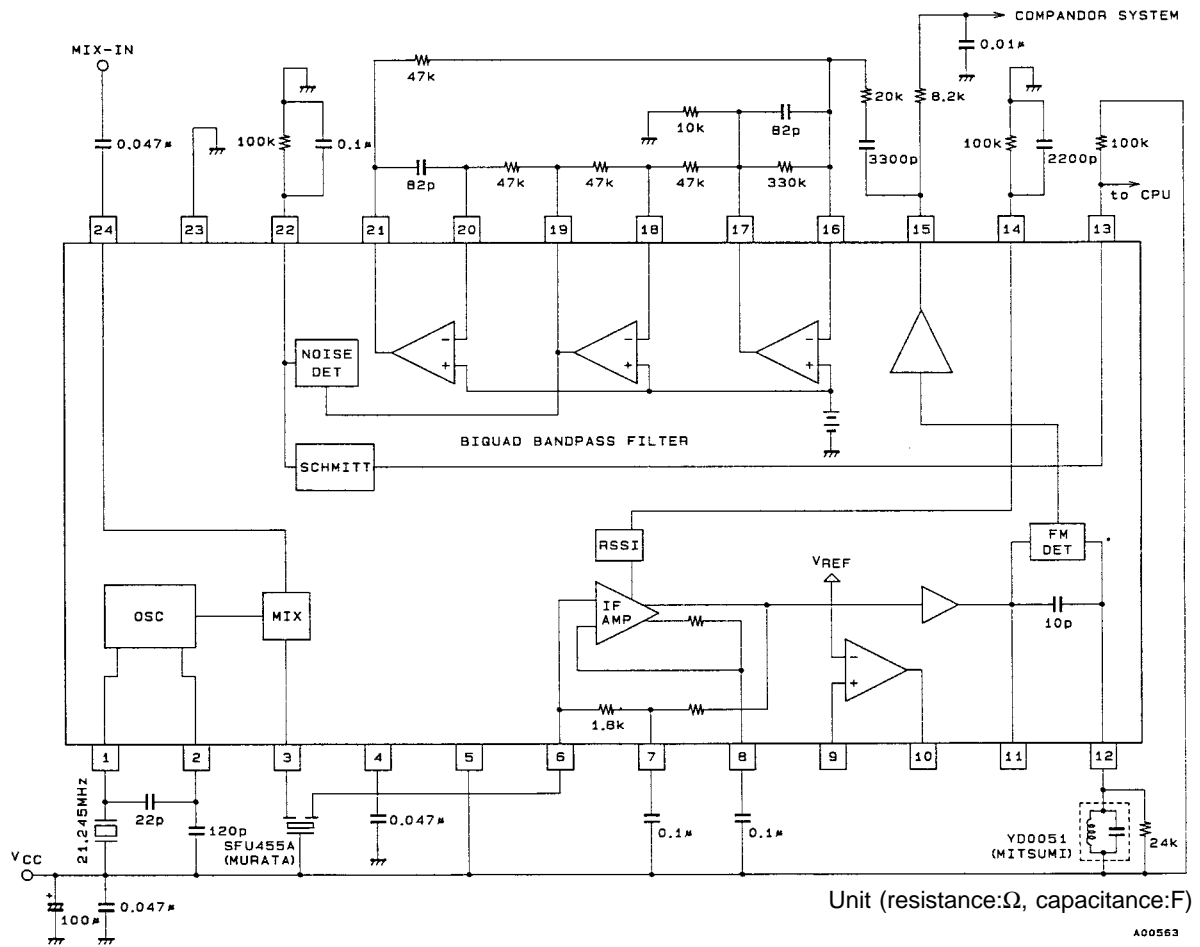

# LA8608V

## Pin Description

Unit (resistance:Ω)

Pin No.	Pin Name	Pin Voltage [V]	Internal equivalent circuit	Remarks
1	CRYSTAL	$V_{CC}$		Forms a Colpitts oscillator.
2	OSC	$V_{CC}-0.7$		
3	MIX-OUT	$V_{CC}-0.3$		MIX buffer output
4	$V_{REF}$	1.2V		Regulated voltage output
5	$V_{CC}$	$V_{CC}$		Power supply
6	IF-IN	$V_{CC}-0.9$		IF amp input
7	D.C1	$V_{CC}-0.9$		IF amp DC feedback
8	D.C2	$V_{CC}-0.9$		
9	COMP (+)			Comparator threshold setting pin; set by external resistance
10	COMP-OUT			Comparator output; open collector
11	LIM.OUT	0.2		Limiter amp output
12	QUAD-COIL	$V_{CC}$		Discriminator connection
13	SCHMITT-OUT			Noise Schmitt output; open collector

Continued on next page.

# LA8608V

Continued from preceding page.

Unit (resistance:Ω)

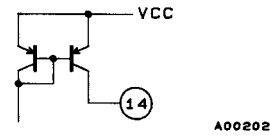
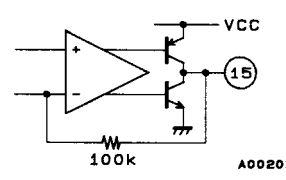
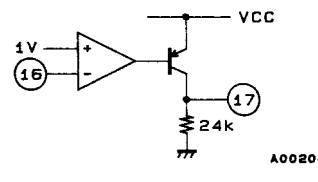
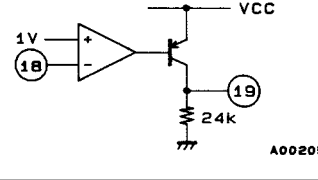
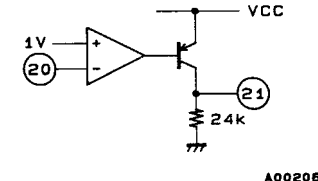
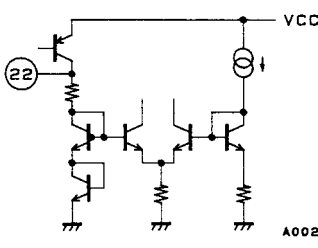
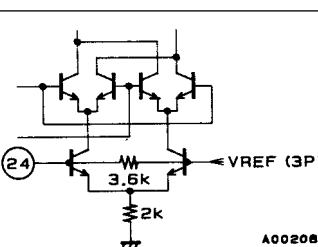
Pin No.	Pin Name	Pin Voltage [V]	Internal equivalent circuit	Remarks
14	S.DET	0.1 to 1.5		Electric field intensity signal output
15	DET-OUT	1.2		FM detection output
16	IN (-)1	1.0		Operational amplifier negative input
17	OUT1	1.0		Operational amplifier output
18	IN (-)2	1.0		Operational amplifier negative input
19	OUT2	1.0		Operational amplifier output
20	IN (-)3	1.0		Operational amplifier negative input
21	OUT3	1.0		Operational amplifier output
22	NOISE-DET	0 to 1.4		Noise wave detection output
23	GND	0		GND
24	MIX-IN	1.2		Mixer input

## IC Usage Notes

### 1. About the local oscillator

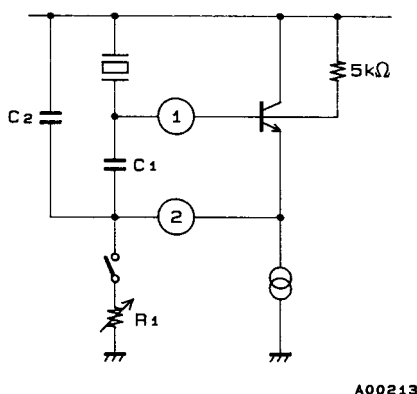
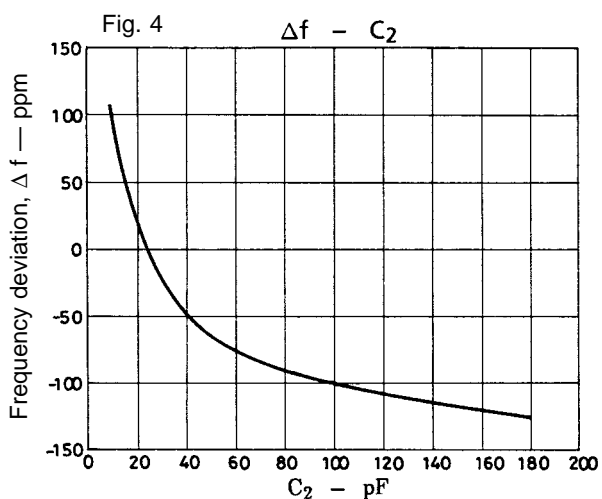
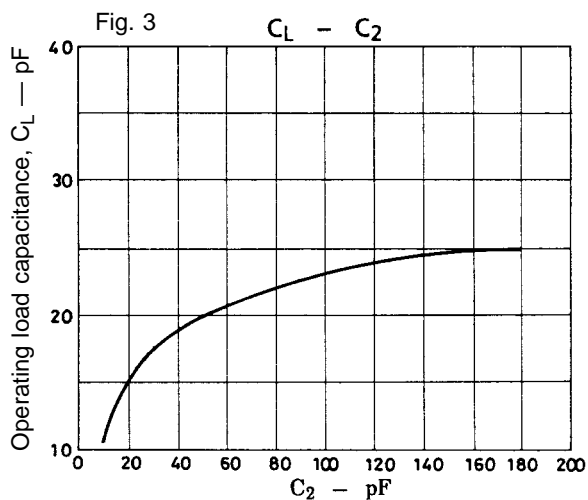
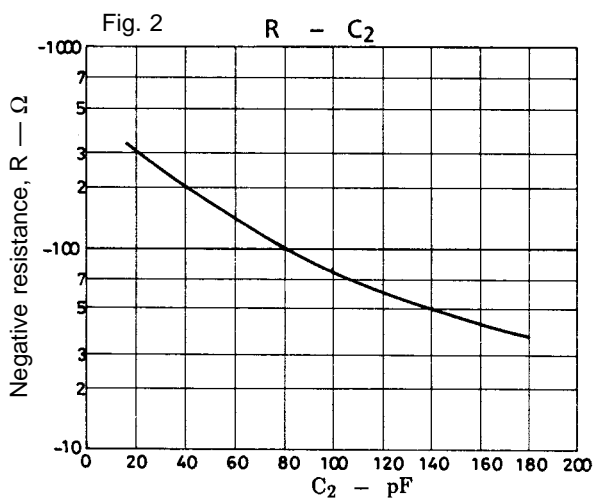

Fig. 1

Fig. 1 shows the equivalent circuit for the local oscillator.

In this circuit, when  $C_1 = 22$  pF, the change in the negative resistance versus  $C_2$  is shown in Fig. 2, the change in the operational load capacitance is shown in Fig. 3, and the frequency deviation is shown in Fig. 4. In the application circuit,  $C_2 = 120$  pF, and in this case the negative resistance according to Fig. 2 is  $-58 \Omega$ . In order to increase the negative resistance, it is necessary to decrease the value of  $C_2$ . To increase the oscillation level, it is possible to add external resistor  $R_1$  and raise the local oscillator current. However, the oscillation level on pin 1 must be set to 110 dB or less. If set to a greater level, distortion will occur in the oscillation waveform.



(Note)  
 Fig 2 to 4:  $C_1 = 22$  pF  
 Figs. 3, 4: Reference to operating load capacitance 16 pF



2. About the built-in operational amplifiers

The LA8608V has three independent operational amplifiers on chip that can be used as needed. If they are not to be used, short the I/O pins.

Sample application 1: Noise amplifier

Using the three operational amplifiers, it is possible to form a secondary biquad bandpass filter. (For details on the filter response characteristics, refer to the data provided later.)

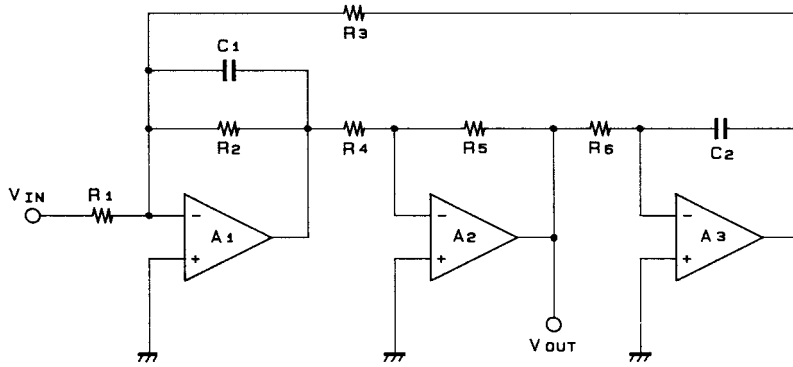

Fig. 5

A00215

The calculation of the transfer function for the above diagram is as shown below.

$$\omega_0^2 = \frac{R_5}{C_1 C_2 R_3 R_4 R_6}$$

$$\frac{\omega_0}{Q} = \frac{1}{C_1 R_2}$$

$$H = \frac{R_2 R_5}{R_1 R_4}$$

In normal use,  $R_3 = R_4 = R_5 = R_6 = R_f$ , and  $C_1 = C_2 = C_f$ :  
Therefore,

$$\omega_0 = \frac{1}{C_f R_f} \quad Q = C_f R_2 \times \omega_0 \quad H = \frac{R_2 R_f}{R_1 R_f}$$

$$f_O = \frac{1}{2\pi C_f R_f} = \frac{R_2}{R_f} = \frac{R_2}{R_1}$$

$f_o$  = center frequency,  $H$  = pass band gain,  $Q$  = selectivity

Noise amplified by this amp passes through the noise detector, and is detected by R and C connected to pin 22. The Schmitt circuit operates on the basis of this DC, and the Schmitt output appears on pin 13. Because the pass band gain is determined by R2/R1, changing these resistances makes it possible to vary the Schmitt circuit level to some extent. By varying the level, it is possible to continue operating Schmitt circuit up to a signal-to-noise ratio of approximately 30 dB on the No. 2 mixer input. To continue operating Schmitt circuit at a higher S/N ratio, add a resistor between pin 17 and GND. This makes it possible to increase the signal-to-noise ratio of the input level at which the Schmitt circuit continue operating by approximately 10 dB. (Refer to Fig. 6.)

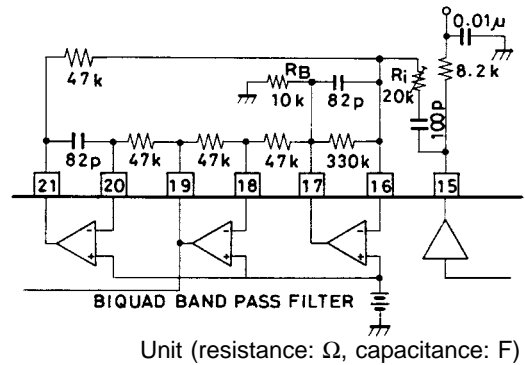
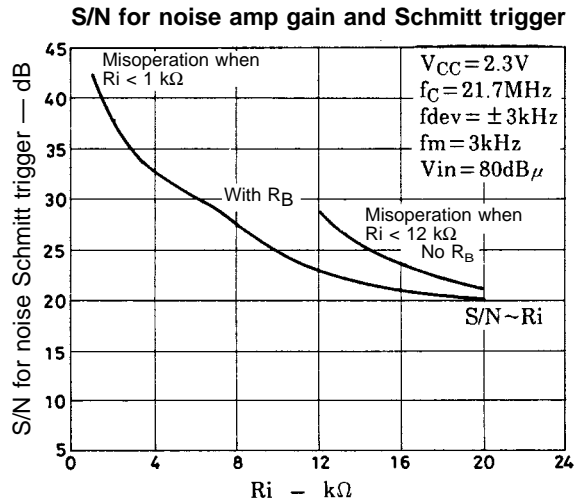

Fig. 6

Sample application 2:

(1) When an operational amplifier is used in a signal system amplifier, etc., connect a capacitor of about 1000 pF between the output (pins 17, 19, 21) and GND. This capacitor prevents local oscillation when the signal is clipped on the negative side.

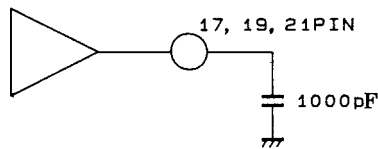

Fig. 7

A00216

(2) When used in the signal system amplifier, etc. and the dynamic range of the output must be expanded, use the scheme described below.

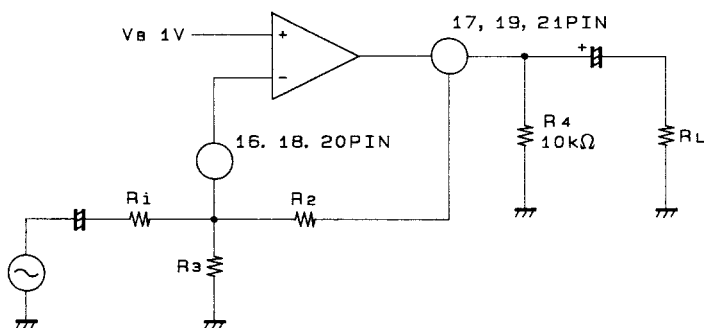

Fig. 8

A00217

1) Use  $R_{B1}$  to set the output DC voltage to approximately  $1/2V_{CC}$ .  
Output DC voltage

$$V_{ODC} = V_B \left(1 + \frac{R_2}{R_3}\right)$$

$$V_B = 1 \text{ V}$$

2) Add 10 kΩ between the output pin and GND.

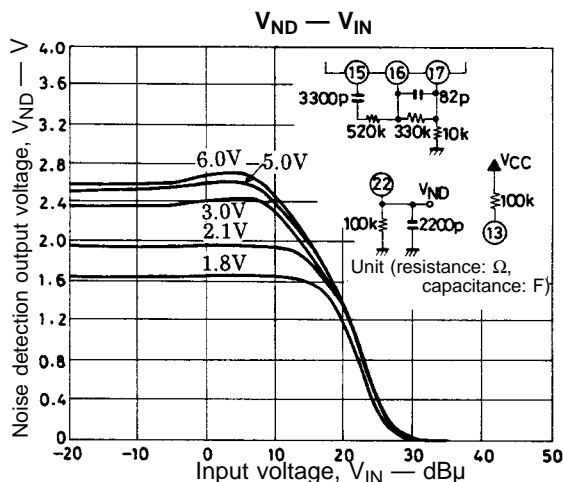
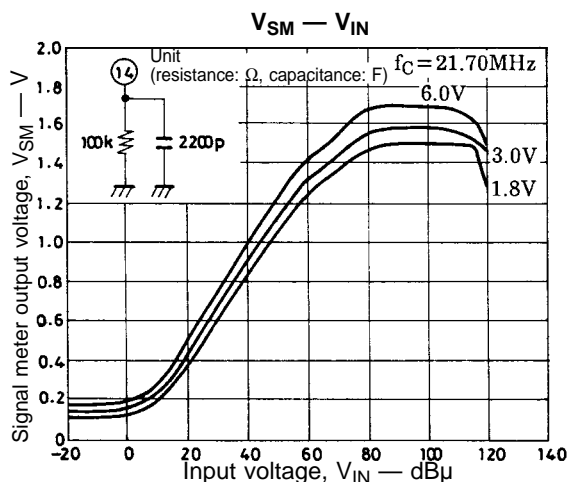
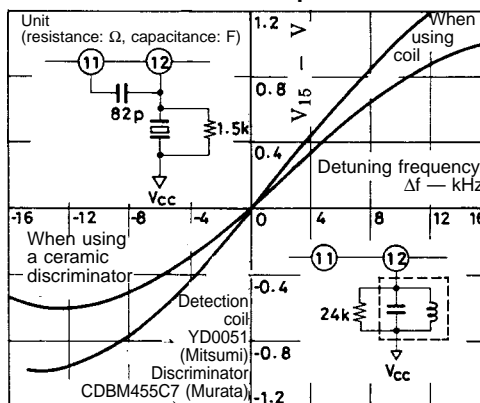
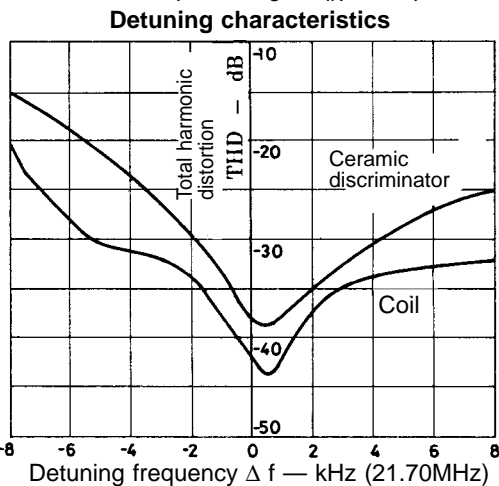
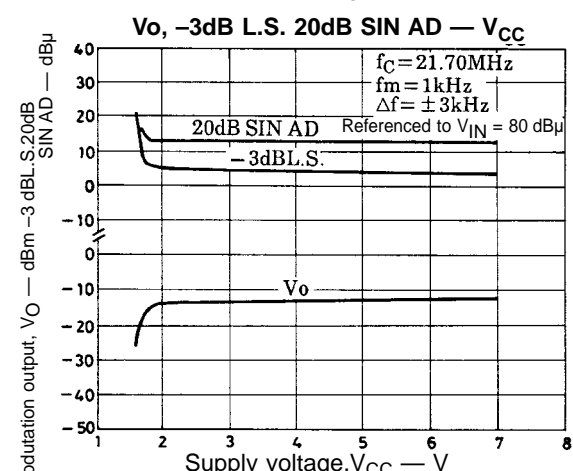
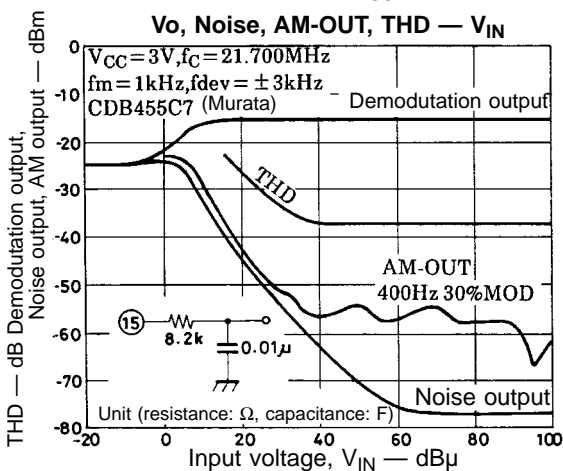
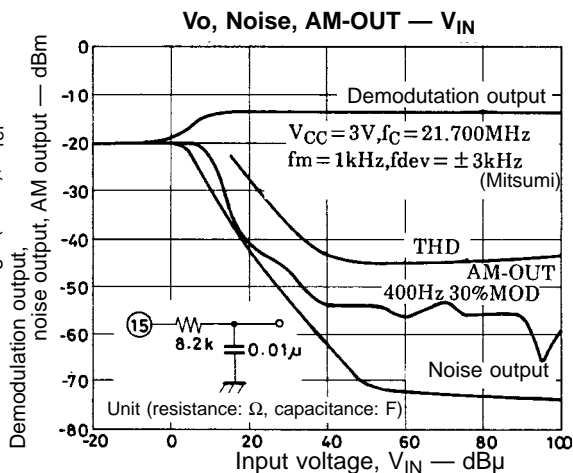
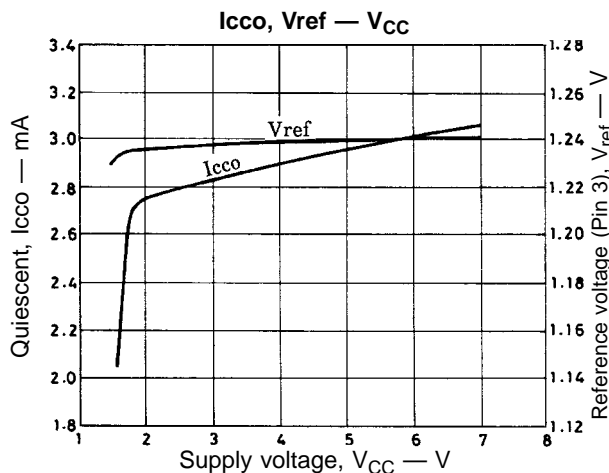

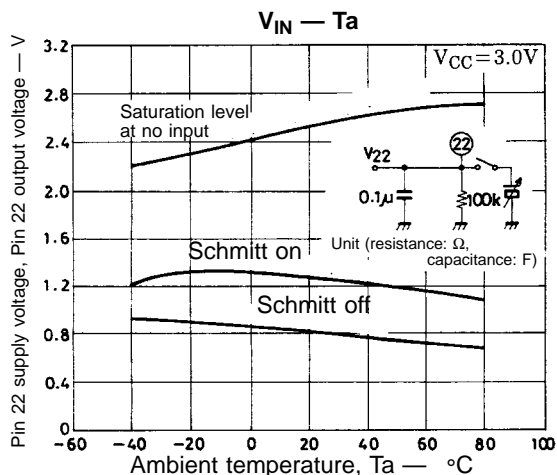
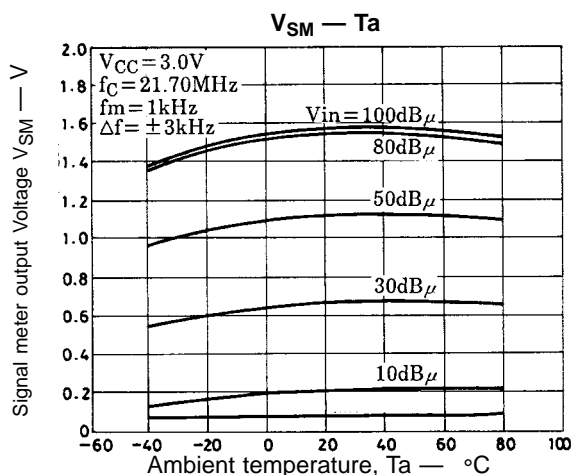
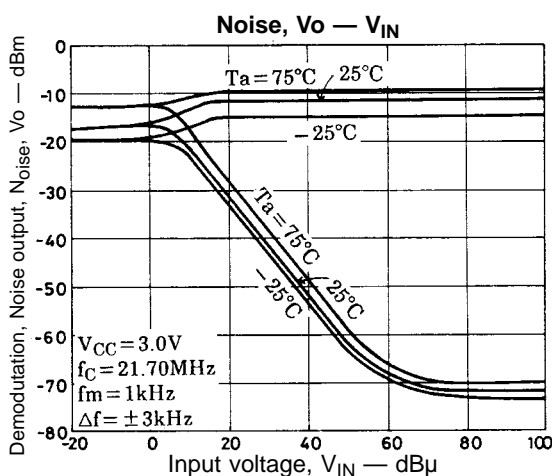
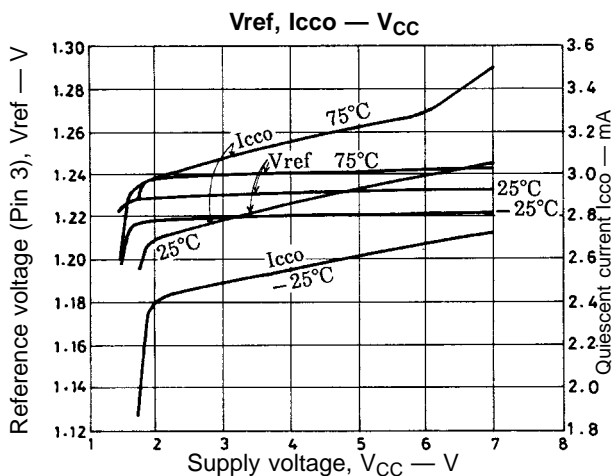
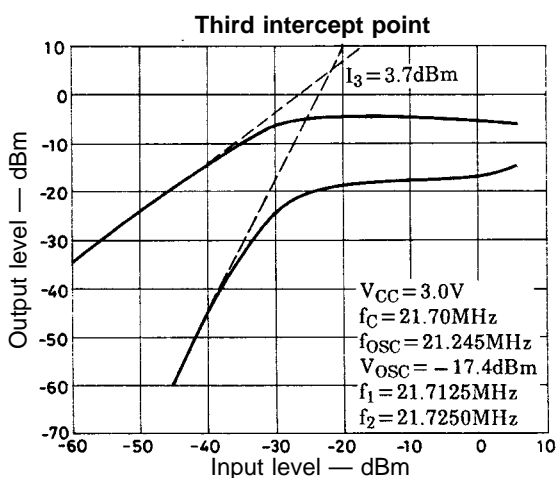
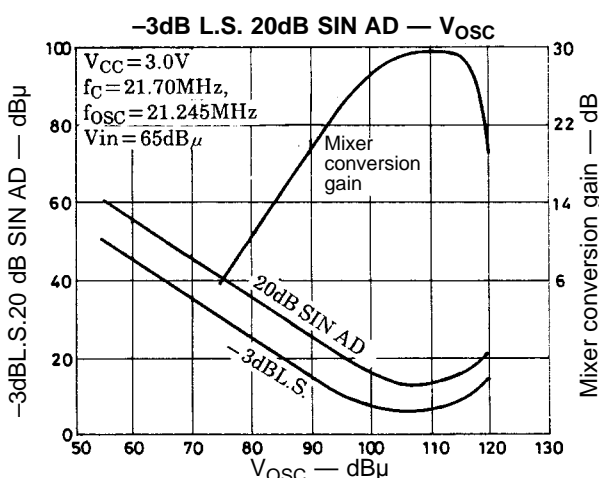
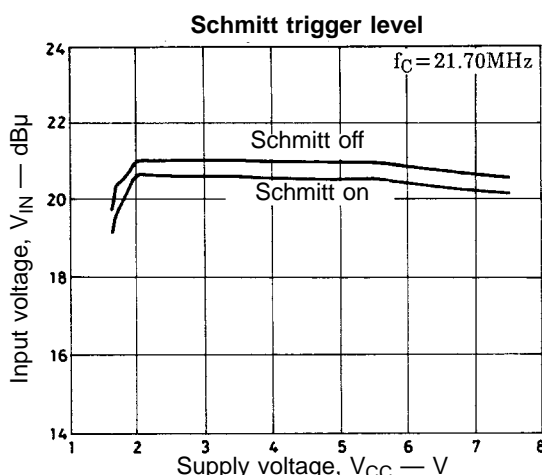
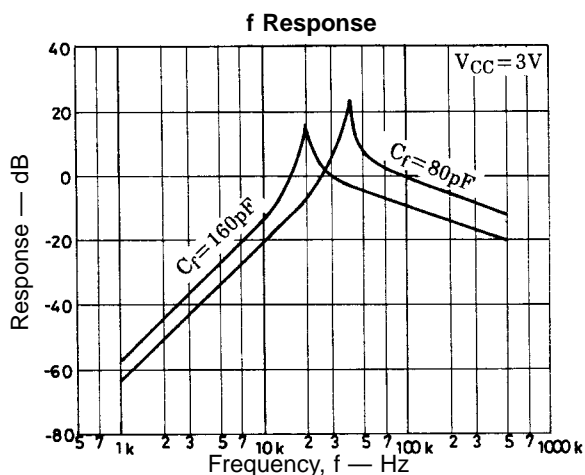

S curve output temperature characteristics (1)

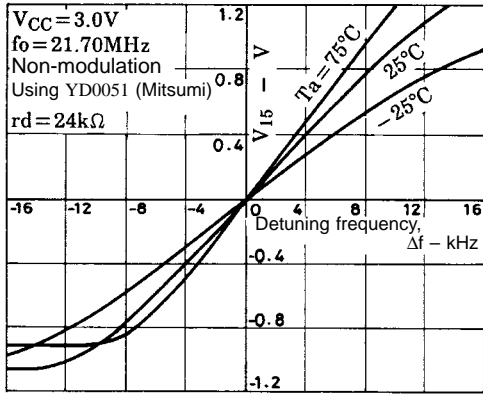

S curve output temperature characteristics (2)

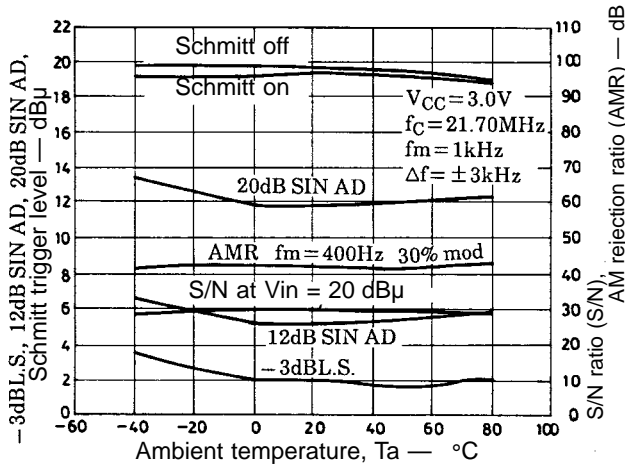
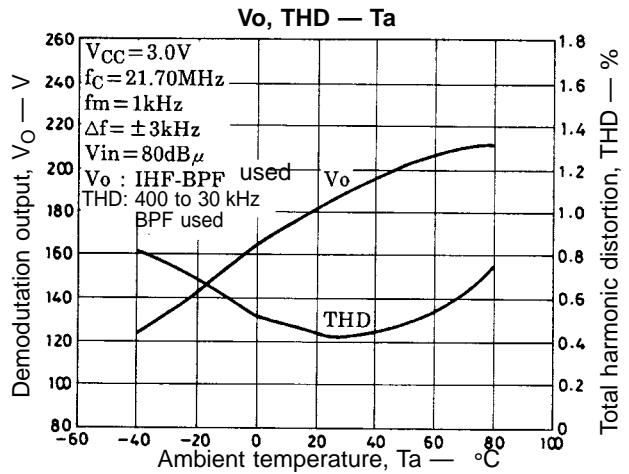
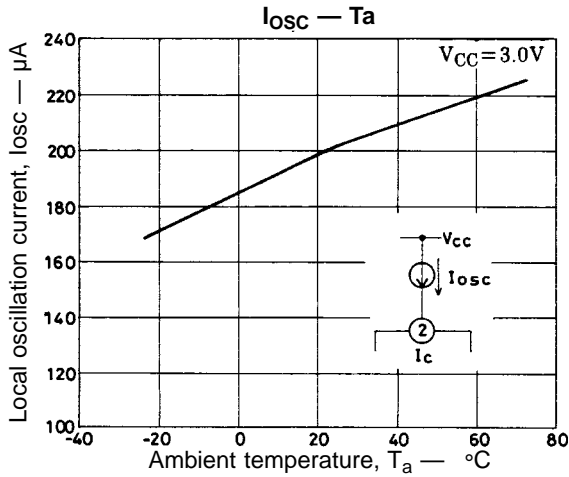
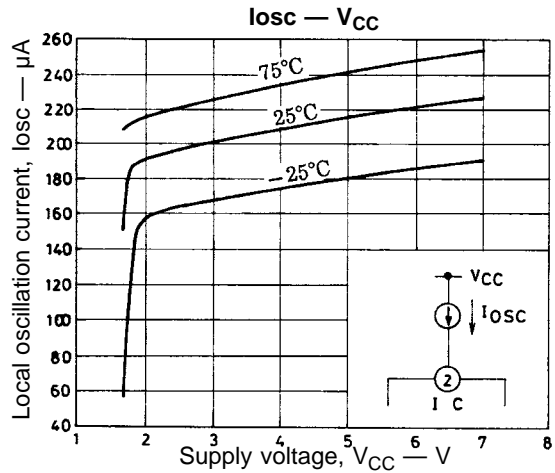
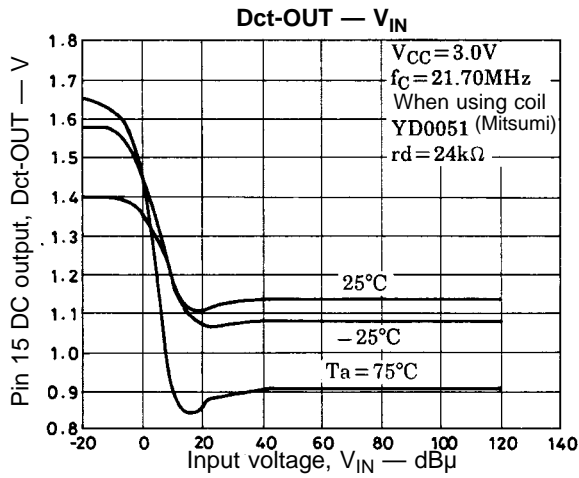
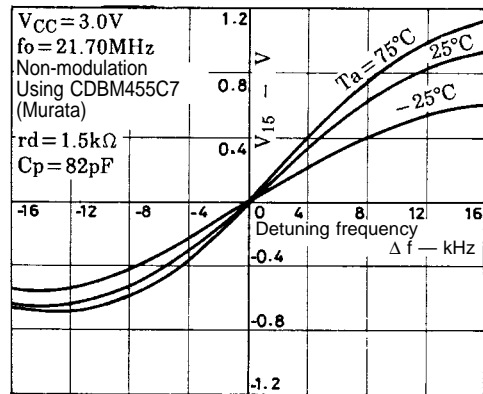

- No products described or contained herein are intended for use in surgical implants, life-support systems, aerospace equipment, nuclear power control systems, vehicles, disaster/crime-prevention equipment and the like, the failure of which may directly or indirectly cause injury, death or property loss.
- Anyone purchasing any products described or contained herein for an above-mentioned use shall:
  - ① Accept full responsibility and indemnify and defend SANYO ELECTRIC CO., LTD., its affiliates, subsidiaries and distributors and all their officers and employees, jointly and severally, against any and all claims and litigation and all damages, cost and expenses associated with such use:
  - ② Not impose any responsibility for any fault or negligence which may be cited in any such claim or litigation on SANYO ELECTRIC CO., LTD., its affiliates, subsidiaries and distributors or any of their officers and employees jointly or severally.
- Information (including circuit diagrams and circuit parameters) herein is for example only; it is not guaranteed for volume production. SANYO believes information herein is accurate and reliable, but no guarantees are made or implied regarding its use or any infringements of intellectual property rights or other rights of third parties.

This catalog provides information as of May, 1995. Specifications and information herein are subject to change without notice.