

**SANYO****LB1696****3-phase Brushless Motor Driver****Overview**

The LB1696 is a 3-phase brushless motor driver IC that is ideal for driving DC fan motors in air conditioners, hot-water supply systems, and the like. The LB1696 has a regulator built in, and can be used with a single power supply (motor power supply only).

**Features**

- 3-phase brushless motor driver.
- Withstand voltage: 60 V; output current: 2.5 A.
- Current limiter built in.
- Low-voltage protector built in.
- Thermal shutdown protector built in.
- Hall amplifier with hysteresis built in.
- FG output function.
- Regulator built in.

**Specifications****Absolute Maximum Ratings at Ta = 25 °C**

Parameter	Symbol	Conditions	Ratings	Unit
Maximum supply voltage	$V_{CC}$ max		10	V
	$V_M$ max		60	V
Output current	$I_O$		2.5	A
Allowable power dissipation	$P_d$ max1	Independent IC	3	W
	$P_d$ max2	With arbitrarily large heat sink	20	W
Operating temperature	$T_{opr}$		-20 to +100	°C
Storage temperature	$T_{stg}$		-55 to +150	°C

**Allowable Operating Ranges at Ta = 25 °C**

Parameter	Symbol	Conditions	Ratings	Unit
Supply voltage range	$V_{CC}$		4.5 to 6.0	V
	$V_M$		5 to 56	V
Regulator input voltage	$V_M(REG)$		7 to 56	V
$V_{REG}$ pin output current	$I_{REGO}$		400(max)	μA
Power supply voltage rise rate	$\Delta V_{CC}/\Delta t$	$V_{CC} = V_{LVSD}(OFF)$ point*1	to 0.04	V/μs
	$\Delta V_M/\Delta t$	$V_M = 0$ V point*1	to 0.16	V/μs

\*1 If the supply voltage rise rate is fast when power is applied, through current may flow to output.

**Package Dimensions**

unit : mm

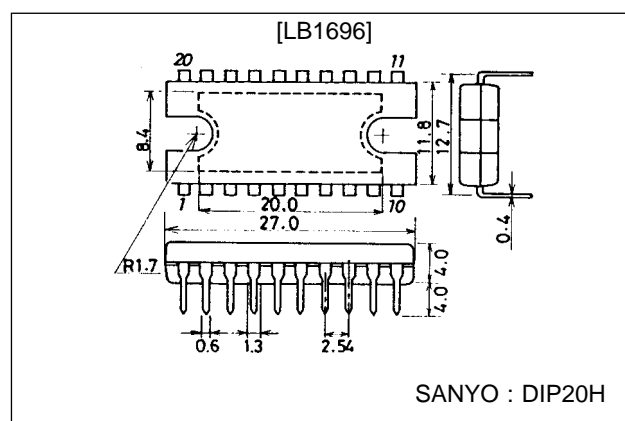
**3037A-DIP20H**

## LB1696

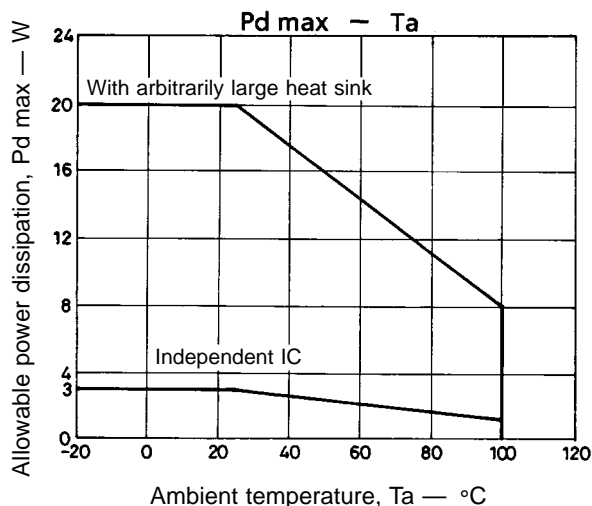

### Electric Characteristics at Ta = 25 °C, V<sub>CC</sub> = 5 V, V<sub>M</sub> = 45 V

Parameter	Symbol	Conditions	min	typ	max	Unit
Supply current	I <sub>CC</sub>	Forward		16	23	mA
Output saturation voltage	V <sub>Osat1</sub>	I <sub>O</sub> = 1 A, V <sub>O</sub> (sink) + V <sub>O</sub> (source)		2.1	3.0	V
	V <sub>Osat2</sub>	I <sub>O</sub> = 2 A, V <sub>O</sub> (sink) + V <sub>O</sub> (source)		3.0	4.2	V
Output leakage current	I <sub>O(leak)</sub>				100	μA
Hall amplifier						
Input bias current	I <sub>HB</sub>			1	4	μA
Common-mode input voltage range	V <sub>ICM</sub>		1.5		3.2	V
Hysteresis width	ΔV <sub>IN</sub>		27	32	36	mV
Input voltage L → H	V <sub>SLH</sub>		8	16	23	mV
Input voltage H → L	V <sub>SHL</sub>		-23	-16	-8	mV
FG pin (rate pulse output)						
Output low level voltage	V <sub>FGL</sub>	I <sub>FG</sub> = 5 mA			0.4	V
Dull-up resistance	R <sub>FG</sub>		7.5	10	12.5	kΩ
Forward F/R operation	V <sub>FR1</sub>			0	0.8	V
Reverse F/R operation	V <sub>FR2</sub>		4.2	5.0		V
Current limit operator limiter	V <sub>RF</sub>		0.42	0.5	0.6	V
Thermal shutdown operation temperature	T <sub>SD</sub>	Design target	150	165		°C
Hysteresis width	ΔT <sub>SD</sub>	Design target		25		°C
Reduced voltage protection operation voltage	V <sub>LVSD</sub>		3.5	3.8	4.1	V
Reduced voltage protection release voltage	V <sub>LVSD(OFF)</sub>			4.3	4.5	V
Hysteresis width	ΔV <sub>LVSD</sub>		0.4	0.5	0.6	V
C pin charge current 1	I <sub>CL1</sub>	R1 = 68 kΩ, R2 = open	15	21	27	μA
C pin charge current 2	I <sub>CL2</sub>	R1 = 68 kΩ, R2 = 10 kΩ	111	158	205	μA
C pin discharge current	I <sub>CH</sub>	R1 = 68 kΩ	168	225	282	μA
C pin charge start voltage	V <sub>CL</sub>	R1 = 68 kΩ	0.3	0.4	0.5	V
C pin discharge start voltage	V <sub>CH</sub>	R1 = 68 kΩ	1.5	2.0	2.5	V
Output current neglect time	t <sub>sm</sub>	R1 = 68 kΩ, C = 6800 pF	42	51	60	μs
Output off time 1	t <sub>so1</sub>	R1 = 68 kΩ, R2 = open, C = 6800 pF	462	545	628	μs
Output off time 2	t <sub>so2</sub>	R1 = 68 kΩ, R2 = 10 kΩ, C = 6800 pF	51	74	97	μs
Regulator output voltage	V <sub>CC(REG)</sub>		4.5	5.2	5.9	V

# LB1696

## Truth Table

	Input			F/R control	Output	FG output	
	IN1	IN2	IN3	F/R	Source → Sink	FG1	FG2
1	H	L	H	L	OUT2 → OUT1	L	L
				H	OUT1 → OUT2		
2	H	L	L	L	OUT3 → OUT1	L	H
				H	OUT1 → OUT3		
3	H	H	L	L	OUT3 → OUT2	L	L
				H	OUT2 → OUT3		
4	L	H	L	L	OUT1 → OUT2	H	H
				H	OUT2 → OUT1		
5	L	H	H	L	OUT1 → OUT3	H	L
				H	OUT3 → OUT1		
6	L	L	H	L	OUT2 → OUT3	H	H
				H	OUT3 → OUT2		

F/R

FG output

Forward L 0.0 to 0.8 V  
Reverse H 4.2 to 5.0 V

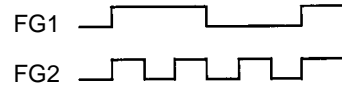

## Pin Assignment

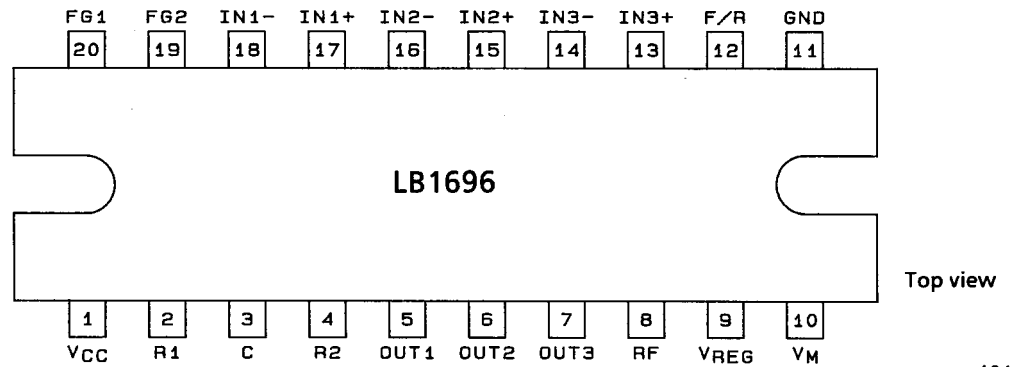

A04691

Block Diagram and Peripheral Circuit Diagram

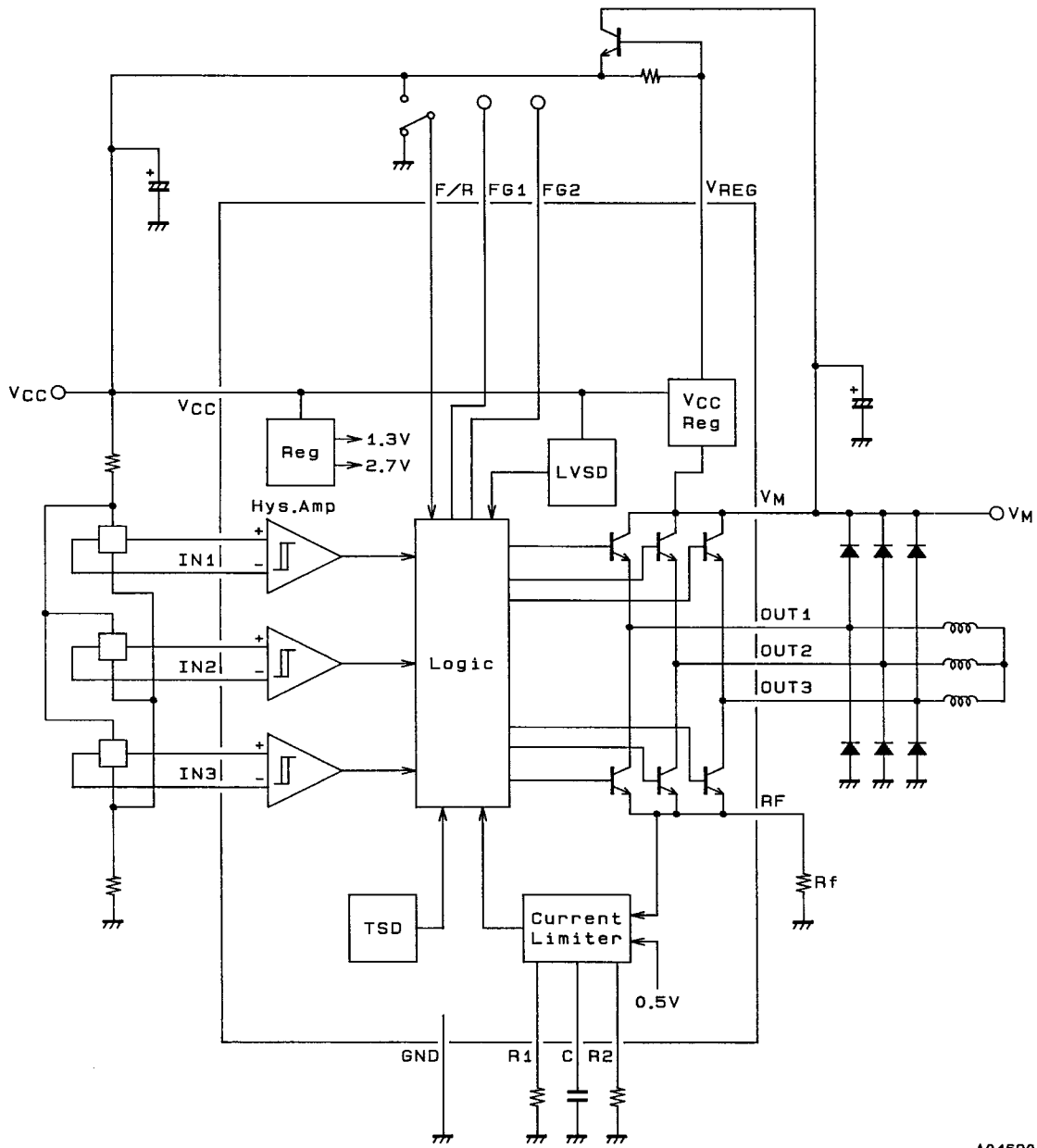

A04690

# LB1696

## Pin Functions

Pin No.	Pin Name	Pin Voltage	Equivalent Circuit	Pin Function
1	V <sub>CC</sub>			Supplies power to all circuits except output block.
2	R1			Sets the C pin charge/discharge current. In current limiter operation when the motor is locked, the charge current set by this pin becomes charge current I <sub>CL1</sub> for the C pin.
3	C			Sets the output off time and output current neglect time during current limiter operation.
4	R2			Sets the C pin charging current. In current limiter operation when the motor is rotating, the sum of the current set by this pin and the current I <sub>CL1</sub> set by the R1 pin becomes charge current I <sub>CL2</sub> for the C pin.
5 6 7	OUT1 OUT2 OUT3			Output pin 1 Output pin 2 Output pin 3
8	RF			Output current detection pin. By inserting resistor R <sub>f</sub> between this pin and GND, the output current is detected as voltage. The output current is limited to a current value set by V <sub>RF</sub> /R <sub>f</sub> (current limit operation).
10	V <sub>M</sub>			Power supply pin providing output
9	V <sub>REG</sub>			Regulator pin. When using a single power supply (V <sub>M</sub> ), V <sub>CC</sub> (5.2 V) is supplied by adding an external transistor. The recommended transistor is the 2SD1724T. If a regulator is not used, this pin should either be open or grounded.
11	GND			GND for other than output. The minimum potential of output transistor is the RF pin voltage.
12	F/R	0.0 V min V <sub>CC</sub> max		Forward/reverse control pin.
17, 18 15, 16 13, 14	IN1 <sup>+</sup> , IN1 <sup>-</sup> IN2 <sup>+</sup> , IN2 <sup>-</sup> IN3 <sup>+</sup> , IN3 <sup>-</sup>	1.5 V min V <sub>CC</sub> - 1.8 V max		Hall device input pin Logic "H" represents IN <sup>+</sup> > IN <sup>-</sup> .
19 20	FG2 FG1			Rate pulse output pin 2. Pull-up resistor built in. Rate pulse output pin 1. Pull-up resistor built in.

## 1. Hall input circuit

The Hall input circuit is a differential amplifier with hysteresis (32 mV typ). The operating DC level must be within the common mode input voltage range (1.5 V to  $V_{CC} - 1.8$  V). An input level that is at least three times greater than the hysteresis (from 120 to 160 mVp-p) is recommended to be independent of noise, etc. If the handling capability needs to be considered in noise evaluation, etc., connect a capacitor (about 0.01  $\mu$ F) between the Hall inputs  $IN^+$  and  $IN^-$ .

## 2. Protectors

### 2-1. Reduced voltage protector

If  $V_{CC}$  drops below the prescribed voltage ( $V_{LVSD}$ ), the output transistor on the sink side turns off. This protector prevents malfunction which may occur when  $V_{CC}$  is reduced.

### 2-2. Thermal shutdown protector

If the junction temperature exceeds the prescribed temperature ( $T_{SD}$ ), the output transistor on the sink side turns off. This protector prevents the IC from being damaged by heat. Thermal design must be such that no operation is performed in other modes than abnormality.

## 3. FG output circuit

IN1, IN2, and IN3 Hall input signals are composited and wave shaped to be output. FG1 has the same frequency as for Hall input, while FG2 3-fold as many.

## 4. Forward/reverse controller

No forward/reverse (F/R) switching is assumed to be performed during motor running period. If F/R switching is performed during motor running period, through current flows to output and ASO needs to be considered. It is recommended that F/R switching be performed when the  $V_M$  power supply is off (in motor stop mode).

## 5. $V_{CC}$ and $V_M$ power supplies

If the supply voltage ( $V_{CC}$ ,  $V_M$ ) rise rate is fast when power is applied, through current flows to output and ASO needs to be considered. The supply voltage rise rate must be such that  $\Delta V_{CC}/\Delta t = 0.04$  V/ $\mu$ s or less and  $\Delta V_M/\Delta t = 0.16$  V/ $\mu$ s or less. The desirable order of applying power is  $V_{CC}$  on first and then  $V_M$  on. The desirable of turning off power supply is  $V_M$  off first and then  $V_{CC}$  off after motor stop. If, after  $V_M$  is turned off,  $V_{CC}$  is turned off during motor's inertial running, some types of motors have a possibility that  $V_M$  voltage rises, exceeding the withstand voltage. Because the LB1696 has a regulator built in, it can be used with a single power supply ( $V_M$  power supply only). In this case,  $V_{CC}$  (5.2 V typ.) can be supplied by connecting an external transistor (NPN) and resistor to the  $V_{REG}$  pin. If the regulator is not used, the  $V_{REG}$  pin must be left open or connected to GND.

## 6. Power supply stabilization capacitor

Great fluctuations in the  $V_{CC}$  line may cause the reduced-voltage protector, etc. to malfunction. A capacitor (of several  $\mu$ F) needs to be connected to the  $V_{CC}$  line (between  $V_{CC}$  and GND) for stabilization. Since a large switching current flows in the line, wiring inductance component etc. fluctuates. Because there are also fluctuations in the GND line, a capacitor needs to be connected to the  $V_M$  line (between  $V_M$  and GND) for stabilization, thus preventing malfunction and keeping withstand voltage from being exceeded. Especially when the routing of wiring ( $V_M$ ,  $V_{CC}$ , or GND) is long, be sure to connect capacitors with adequate capacity for power line stabilization.

7. Current limiter

The current limiter turns off the sink side output transistor when the output current-set current value (limiter value) is reached. The output current is limited by the limit value. The RF pin is used to detect the output current. The output current is detected as voltage by connecting resistor  $R_f$  between RF pin and GND. When the RF pin voltage reaches 0.5 V (typ), the current limiter operates so that the output current is limited to the  $0.5/R_f$ -set limiter value.

7-1. Output off time

The current limiter is so designed that current limit function turns on to turn off the sink side output transistor and then turn on the transistor again after off period of a fixed time (output off time) has elapsed. Since the LB1696 uses this output switching method for the current limiter, the ASO problems when current limitation goes into operated mode as compared with the output unsaturated current limited one. In addition, by separating current limiter operation into two modes, one when the motor is locked and one when the motor is rotating (during start-up), it was possible to implement a current limiter circuit with excellent motor start-up characteristics. The explanation of current limiter operation below is divided into two parts: one for the mode used when the motor is locked and one for the mode used when the motor is rotating. The output off time depends on the charge time of capacitor C connected to the C pin. When the current limiter turns on, C begins charging and the output is kept off until C is charged up to 2 V (typ). When C has been charged up to 2 V, the sink side output turns on again. The C charging current is a constant-regulated current, which depends on resistor R1 connected to the R1 pin and resistor R2 connected to the R2 pin. In the LB1696, the charge current can be switched for when the motor is locked and for when the motor is rotating in order to support motors for a large number of applications. As a result, it is possible to set the output off time so that it is different for when the motor is locked and for when the motor is rotating. By setting the output off time so that it is shorter when the motor is rotating (at start-up) as opposed to when the motor is locked, it is possible to reduce the decrease in torque at start-up caused by the output off time. The charge currents and output off times for when the motor is locked and for when the motor is rotating are as follows:

(1) Charge current  $I_{CL1}$  and output off time  $t_{off1}$  when the motor is locked

$$\begin{aligned} I_{CL1} &\cong 1.4/R1 \\ t_{off1} &\cong C/I_{CL1} \times 2.0 \\ &\cong 1.42 \times R1 \times C \\ &\text{(R1 must be set between 14 k}\Omega\text{ and 100 k}\Omega\text{.)} \end{aligned}$$

(2) Charge current  $I_{CL2}$  and output off time  $t_{off2}$  when the motor is rotating

$$\begin{aligned} I_{CL2} &\cong I_{CL1} + (1.4/R2) \\ t_{off2} &\cong C/I_{CL2} \times 2.0 \\ &\cong 1.42 \times R \times C \{R = R1 \times R2/(R1 + R2)\} \\ &\text{(R2 must be set between 7 k}\Omega\text{ and 100 k}\Omega\text{.)} \end{aligned}$$

## 7-2. Output current neglect time

While the current limiter turns on and the sink side output is off, the regeneration current flows through the external diode used for absorbing the regeneration current above the output that was turned off. After the output off time elapses and the sink side output is turned on again, reverse current flows momentarily through the external diode (for the diode's reverse recovery time), causing a current that reaches the limiter value to flow momentarily through the output. Because this current will cause current limiter to turn on again, turning off the output, the average current decreases, causing the torque to be decreased at motor start-up, etc. Therefore, in order to prevent this current from being detected, the current limiter is designed so that the output current is not detected for a fixed period of time after the sink side output is turned on again. This length of time is the output current neglect time. The output current neglect time is determined by the discharge time of the capacitor C connected to the C pin. When current limiter turns on and C charges to 2 V, C begins discharging, and the output current neglect time is the time it takes for C to discharge to the point where the voltage at C is 0.4 V (typ). The C discharge current is a constant current, and is set at about 11 times the  $I_{CL1}$  of charge current when the motor is locked. As a result, the output current neglect time is about 1/11 of the output off time when the motor is locked. Because the C discharge current is the same whether the motor is locked or is rotating, the output current neglect time is also the same whether the motor is locked or is rotating. The C discharge current  $I_{CH}$  and the output current neglect time  $t_{sm}$  are determined according to the following equations:

$$\begin{aligned} I_{CH} &\cong 1.4/R1 \times 11 \\ t_{sm} &\cong C/I_{CH} \times 1.6 \\ &\cong 0.10 \times R1 \times C \end{aligned}$$

Because there is a slope to the time at which the sink side output is turned on again, the reverse current is not very large, even if a rectifier diode (a diode in which the reverse recovery time is not short) is used as the external diode for absorbing the regeneration current in the current limiter.

## 7-3. Output off time setting

It is necessary to set the output off time to a suitable level for the type of motor being used. (The output off time is set by the external resistors connected to the R1 and R2 pins, and by the external capacitor connected to the C pin.) In the LB1696, the output off time when the motor is rotating can be set so that it is shorter than when the motor is locked. Set the optimal output off time for when the motor is locked, and then set the output off time for when the motor is rotating. Fig. 1 shows the current limiter operation waveform.

## (1) When the output off time is set short

The output current neglect time is set by a circuit within the IC to about 1/11 of the output off time when the motor is locked. Therefore, if the output off time is set to a very short length of time, the output current neglect time may not be adequate. If the output current neglect time is inadequate, the current limiter will turn on in response to reverse current from the external diode used to absorb the regeneration current. (Refer to Section 7-2.) Furthermore, if the output off time is short, the diode reverse current becomes large and ASO must be considered.

## (2) When the output off time is set long

If the output off time when the motor is rotating (at motor start-up) is set to a very long length of time, the average current decreases, causing the torque at motor start-up to drop. Depending on the type of motor, it may be impossible to shift from the current limiter operation state to the normal rotation state. In current limiter operation when the motor is locked, it is necessary to set the output time to a comparatively long length of time. Therefore, first set the output off time  $t_{off1}$  for when the motor is locked, and then set the output off time  $t_{off2}$  for when the motor is rotating so that  $t_{off2}$  is shorter than  $t_{off1}$ .



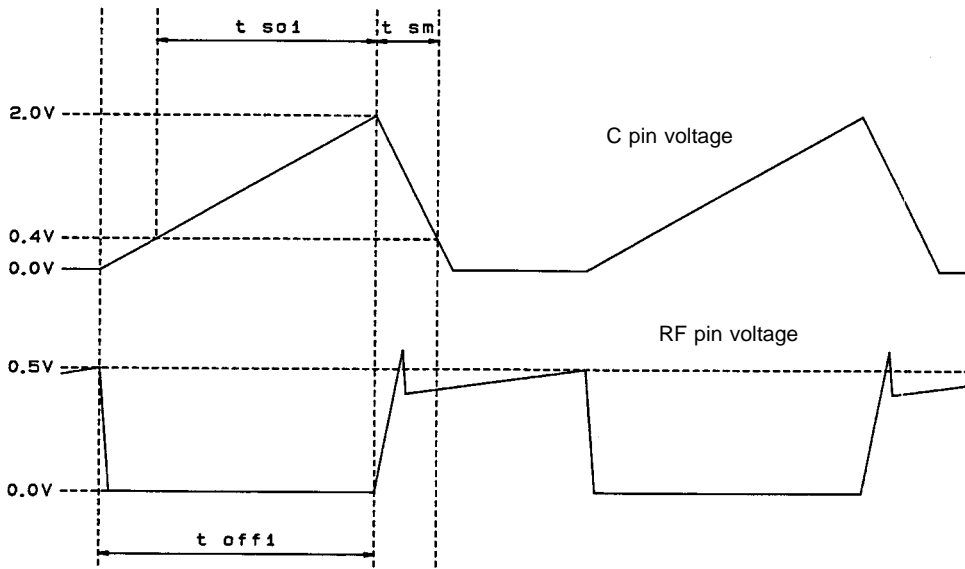

Fig. 1 Current Limiter Operation Waveform (When Motor Is Locked)

8. Calculation of the IC's internal power dissipation

$$P_d = (V_{CC} \times I_{CC}) + (V_M \times I_M) - (\text{power dissipated by the motor coil})$$

9. Measuring the increase in the IC's temperature

Because the temperature of the IC chip cannot be measured directly, the temperature is normally measured using one of the following methods.

9-1. Measurement using a thermocouple

In order to measure the temperature by using a thermocouple, mount the thermocouple on the fin. Although this method of measurement is simple, the measurement error is great, if the rate of heat generation has not stabilized.

9-2. Measurement using the characteristics of a diode within the IC

It is recommended that the parasitic diode between FG1 and GND be used to measure the temperature of the IC. Set FG1 high (the "off" state), measure the parasitic diode voltage  $V_F$ , and calculate the temperature based on the temperature characteristics of the voltage  $V_F$ .

(Sanyo's data:  $I_F = -1 \text{ mA}$ ,  $V_F$  temperature characteristics: approximately  $-2 \text{ mV}/^\circ\text{C}$ )

- No products described or contained herein are intended for use in surgical implants, life-support systems, aerospace equipment, nuclear power control systems, vehicles, disaster/crime-prevention equipment and the like, the failure of which may directly or indirectly cause injury, death or property loss.
- Anyone purchasing any products described or contained herein for an above-mentioned use shall:
  - ① Accept full responsibility and indemnify and defend SANYO ELECTRIC CO., LTD., its affiliates, subsidiaries and distributors and all their officers and employees, jointly and severally, against any and all claims and litigation and all damages, cost and expenses associated with such use:
  - ② Not impose any responsibility for any fault or negligence which may be cited in any such claim or litigation on SANYO ELECTRIC CO., LTD., its affiliates, subsidiaries and distributors or any of their officers and employees jointly or severally.
- Information (including circuit diagrams and circuit parameters) herein is for example only; it is not guaranteed for volume production. SANYO believes information herein is accurate and reliable, but no guarantees are made or implied regarding its use or any infringements of intellectual property rights or other rights of third parties.

This catalog provides information as of December, 1995. Specifications and information herein are subject to change without notice.