



LC321664AJ, AM, AT-80

1 MEG (65536 words × 16 bits) DRAM Fast Page Mode, Byte Write

Overview

The LC321664AJ, AM, AT is a CMOS dynamic RAM operating on a single 5 V power source and having a 65536-word × 16-bit configuration. Equipped with large capacity capabilities, high-speed transfer rates and low power dissipation, this series is suited for a wide variety of applications ranging from computer main memory and expansion memory to commercial equipment.

Address input utilizes a multiplexed address bus which permits it to be enclosed in compact plastic packages of SOJ 40-pin, SOP 40-pin and TSOP 44-pin. Refresh rates are within 4 ms with 256 row address (A0 to A7) selection and support $\overline{\text{RAS}}$ -only refresh, $\overline{\text{CAS}}$ -before- $\overline{\text{RAS}}$ refresh and hidden refresh settings.

There are functions such as page mode, read-modify-write, and byte-write.

Features

- 65536-word × 16-bit configuration
- Single 5 V ±10% power supply
- All input and output (I/O) TTL compatible
- Supports fast page mode, read-modify-write, and byte-write.
- Supports output caching control using early write and Output Enable ($\overline{\text{OE}}$) control.
- 4 ms refresh using 256 refresh cycles
- Supports $\overline{\text{RAS}}$ -only refresh, $\overline{\text{CAS}}$ -before- $\overline{\text{RAS}}$ refresh and hidden refresh.
- Packages
 - SOJ 40-pin (400 mil) plastic package: LC321664AJ
 - SOP 40-pin (525 mil) plastic package: LC321664AM
 - TSOP 44-pin (400 mil) plastic package: LC321664AT
- $\overline{\text{RAS}}$ access time/column address access time/ $\overline{\text{CAS}}$ access time/cycle time/power dissipation

Package Dimensions

unit: mm

3200-SOJ40

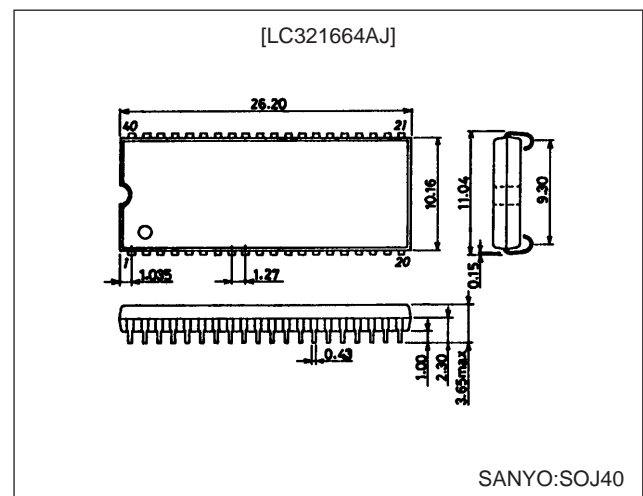

unit: mm

3195-SOP40

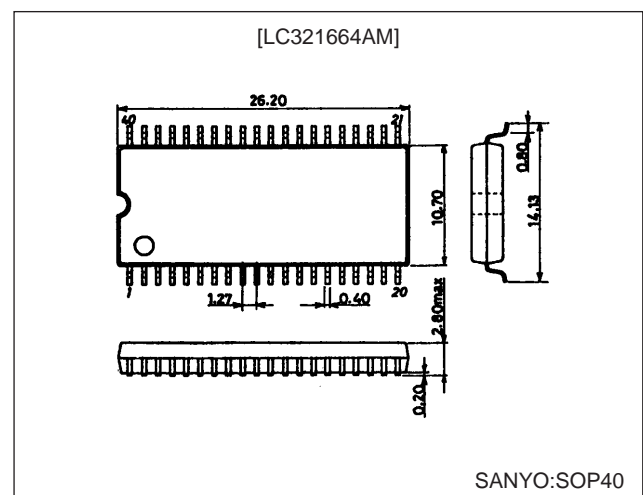

Parameter		LC321664AJ, AM, AT-80
$\overline{\text{RAS}}$ access time		80 ns
Column address access time		45 ns
$\overline{\text{CAS}}$ access time		30 ns
Cycle time		135 ns
Power dissipation (max.)	During operation	633 mW
	During standby	5.5 mW (CMOS level)/11 mW (TTL level)

SANYO Electric Co., Ltd. Semiconductor Business Headquarters

TOKYO OFFICE Tokyo Bldg., 1-10, 1 Chome, Ueno, Taito-ku, TOKYO, 110-0005 JAPAN

Package Dimensions

unit : mm

3207-TSOP44

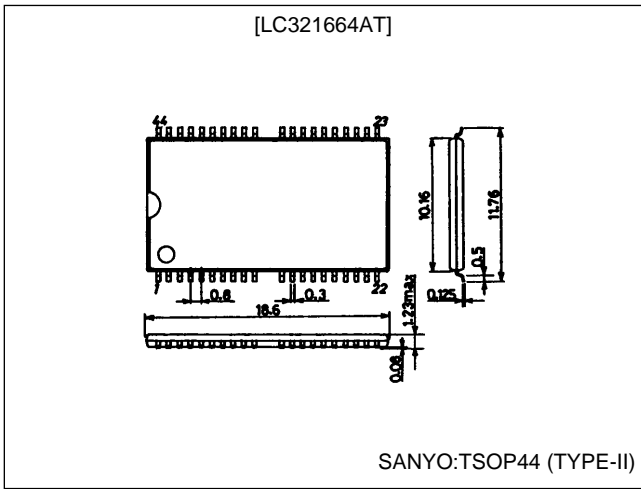

Pin Assignments

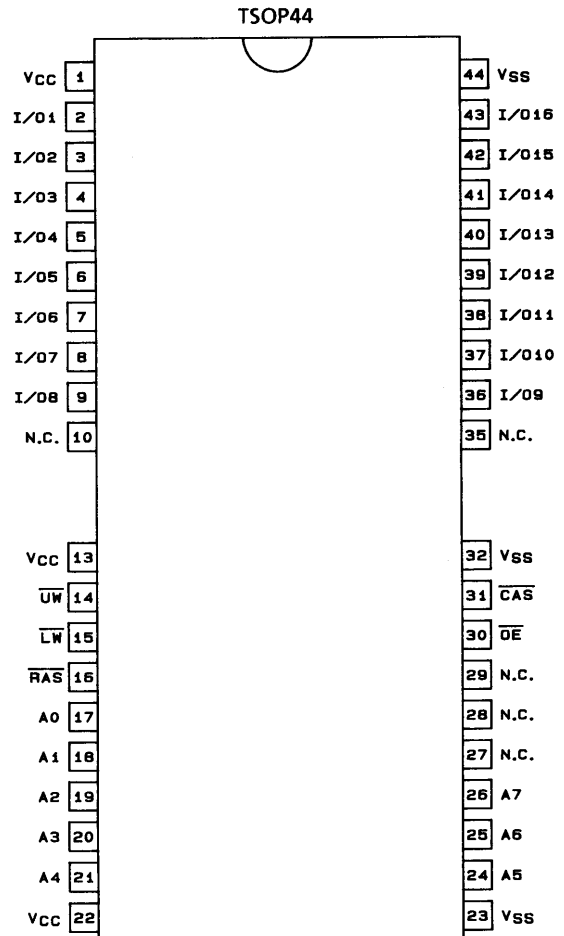
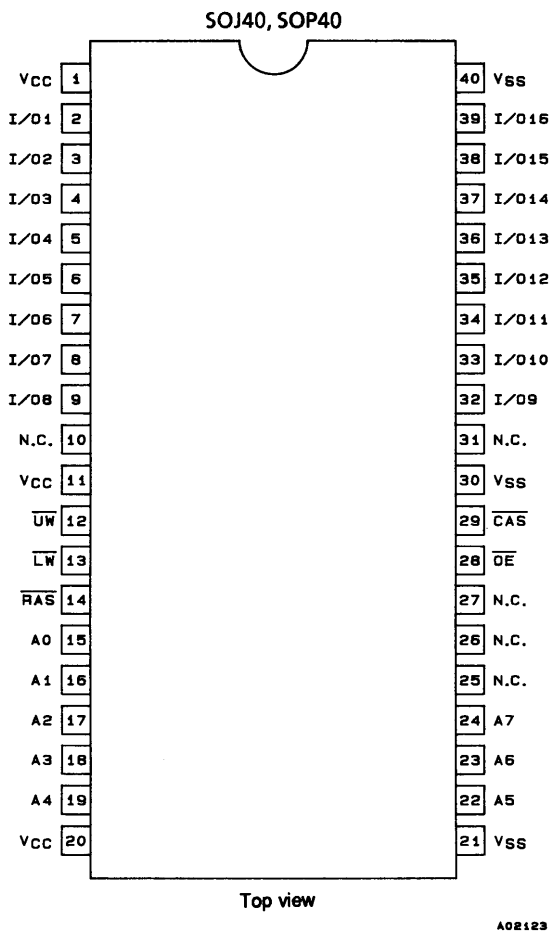

Block Diagram

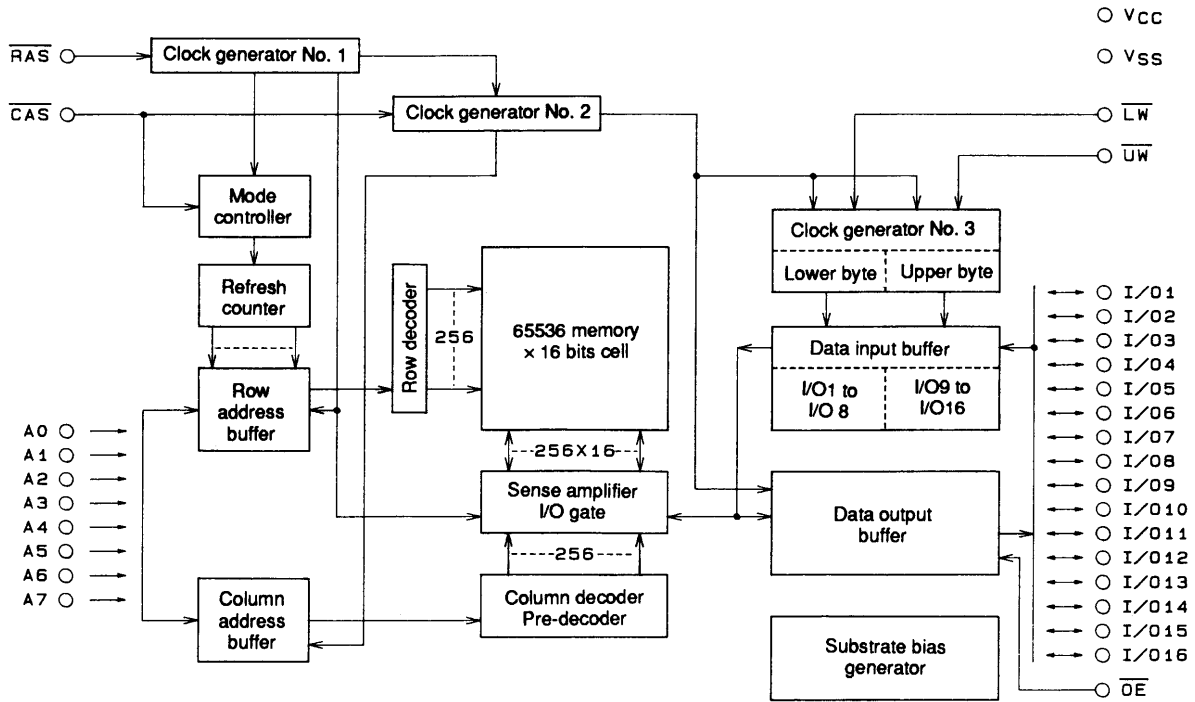

A02125

Specifications

Absolute Maximum Ratings

Parameter	Symbol	Ratings	Unit	Note	
Maximum supply voltage	V_{CC} max	-1.0 to +7.0	V	1	
Input voltage	V_{IN}	-1.0 to +7.0	V	1	
Output voltage	V_{OUT}	-1.0 to +7.0	V	1	
Allowable power dissipation	LC321664AJ, AM LC321664AT	Pd max	800	mW	1
			700		
Output short-circuit current	I_{OUT}	50	mA	1	
Operating temperature range	T_{opr}	0 to +70	°C	1	
Storage temperature range	T_{stg}	-55 to +150	°C	1	

Note: 1) Stresses greater than the above listed maximum values may result in damage to the device.

DC Recommended Operating Ranges at $T_a = 0$ to $+70^\circ\text{C}$

Parameter	Symbol	min	typ	max	Unit	Note
Power supply voltage	V_{CC}	4.5	5.0	5.5	V	2
Input high level voltage	V_{IH}	2.4		6.5	V	2
Input low level voltage (A0 to A7, RAS, CAS, UW, LW, OE)	V_{IL}	-1.0*		+0.8	V	2
Input low level voltage (I/O1 to I/O16)	V_{IL}	-0.5*		+0.8	V	2

Note: 2) All voltages are referenced to V_{SS} .

A bypass capacitor of about 0.1 μF should be connected between V_{CC} and V_{SS} of the device.

* -2.0 V when pulse width is less than 20 ns

LC321664AJ, AM, AT-80

DC Electrical Characteristics at Ta = 0 to + 70°C, V_{CC} = 5 V ± 10%

Parameter	Symbol	Conditions	min	max	Unit	Note
Operating current (Average current during operation)	I _{CC1}	$\overline{\text{RAS}}, \overline{\text{CAS}}$, address cycling: $t_{\text{RC}} = t_{\text{RC min}}$		115	mA	3, 4, 5
Standby current	I _{CC2}	$\overline{\text{RAS}} = \overline{\text{CAS}} = V_{\text{IH}}$		2	mA	
$\overline{\text{RAS}}$ -only refresh current	I _{CC3}	$\overline{\text{RAS}}$ cycling, $\overline{\text{CAS}} = V_{\text{IH}}$: $t_{\text{RC}} = t_{\text{RC min}}$		115	mA	3, 5
Fast page mode current	I _{CC4}	$\overline{\text{RAS}} = V_{\text{IL}}$, $\overline{\text{CAS}}$ address cycling: $t_{\text{PC}} = t_{\text{PC min}}$		70	mA	3, 4, 5
Standby current	I _{CC5}	$\overline{\text{RAS}} = \overline{\text{CAS}} = V_{\text{CC}} - 0.2\text{V}$		1	mA	
$\overline{\text{CAS}}$ -before- $\overline{\text{RAS}}$ refresh current	I _{CC6}	$\overline{\text{RAS}}, \overline{\text{CAS}}$ cycling: $t_{\text{RC}} = t_{\text{RC min}}$		115	mA	3
Input leakage current	I _{IL}	$0\text{V} \leq V_{\text{IN}} \leq 6.5\text{V}$, pins other than measuring pin = 0V	-10	+10	μA	
Output leakage current	I _{OL}	D _{OUT} disable, $0\text{V} \leq V_{\text{OUT}} \leq 5.5\text{V}$	-10	+10	μA	
Output high level voltage	V _{OH}	I _{OUT} = -2.5mA	2.4		V	
Output low level voltage	V _{OL}	I _{OUT} = 2.1mA		0.4	V	

Note: 3) All current values are measured at minimum cycle rate. Since current flows immoderately, if cycle time is longer than shown here value becomes smaller.

- 4) I_{CC1} and I_{CC4} are dependent on output loads. Maximum values for I_{CC1} and I_{CC4} represent values with output open.
- 5) One address change can be performed while $\overline{\text{RAS}} = V_{\text{IL}}$ (I_{CC1} and I_{CC3}).
One address change can be performed during one t_{PC} cycle (I_{CC4}).

LC321664AJ, AM, AT-80

AC Electrical Characteristics at Ta = 0 to +70°C, V_{CC} = 5 V ± 10% (Note 6, 7, 8)

Parameter	Symbol	min	max	Unit	Note
Random read or write cycle time	t _{RC}	135		ns	
Read-write/read-modify-write cycle time	t _{RWC}	180		ns	
Fast page mode cycle time	t _{PC}	55		ns	
Fast page mode Read-write/read-modify-write cycle time	t _{PRWC}	100		ns	
$\overline{\text{RAS}}$ access time	t _{RAC}		80	ns	9, 14, 15
$\overline{\text{CAS}}$ access time	t _{CAC}		30	ns	9, 14
Column address access time	t _{AA}		45	ns	9, 15
$\overline{\text{CAS}}$ precharge access time	t _{CPA}		50	ns	9
Output low-impedance time from $\overline{\text{CAS}}$ low	t _{CLZ}	0		ns	9
Output buffer turn-off delay time	t _{OFF}	0	20	ns	10
Rise or fall time	t _T	3	50	ns	
$\overline{\text{RAS}}$ precharge time	t _{RP}	45		ns	
$\overline{\text{RAS}}$ pulse width	t _{RAS}	80	10000	ns	
$\overline{\text{RAS}}$ pulse width for fast page mode only	t _{RASP}	80	100000	ns	
$\overline{\text{RAS}}$ hold time	t _{RSH}	30		ns	
$\overline{\text{CAS}}$ hold time	t _{CSH}	80		ns	
$\overline{\text{CAS}}$ pulse width	t _{CAS}	30	10000	ns	
$\overline{\text{RAS}}$ to $\overline{\text{CAS}}$ delay time	t _{RCD}	25	50	ns	14
$\overline{\text{RAS}}$ to column address delay time	t _{RAD}	17	35	ns	15
$\overline{\text{CAS}}$ to $\overline{\text{RAS}}$ precharge time	t _{CRP}	10		ns	
$\overline{\text{CAS}}$ precharge time	t _{CP}	10		ns	
Row address setup time	t _{ASR}	0		ns	
Row address hold time	t _{RAH}	12		ns	
Column address setup time	t _{ASC}	0		ns	
Column address hold time	t _{CAH}	20		ns	
Column address hold time referenced to $\overline{\text{RAS}}$	t _{AR}	60		ns	
Column address to $\overline{\text{RAS}}$ lead time	t _{RAL}	45		ns	
Read command setup time	t _{RCS}	0		ns	
Read command hold time referenced to $\overline{\text{CAS}}$	t _{RCH}	0		ns	11
Read command hold time referenced to $\overline{\text{RAS}}$	t _{RRH}	0		ns	11
Write command hold time	t _{WCH}	15		ns	
Write command hold time referenced to $\overline{\text{RAS}}$	t _{WCR}	60		ns	
Write command pulse width	t _{WP}	15		ns	

Continued on next page.

LC321664AJ, AM, AT-80

Continued from preceding page.

Parameter	Symbol	min	max	Unit	Note
Write command to RAS lead time	t_{RWL}	20		ns	
Write command to \overline{CAS} lead time	t_{CWL}	20		ns	
Data input setup time	t_{DS}	0		ns	12
Data input hold time	t_{DH}	20		ns	12
Data input hold time referenced to RAS	t_{DHR}	60		ns	
Refresh period	t_{REF}		4	ms	
Write command setup time	t_{WCS}	0		ns	13
\overline{CAS} to \overline{UW} , \overline{LW} delay time	t_{CWD}	50		ns	13
RAS to \overline{UW} , \overline{LW} delay time	t_{RWD}	100		ns	13
Column address to \overline{UW} , \overline{LW} delay time	t_{AWD}	65		ns	13
\overline{CAS} precharge to \overline{UW} , \overline{LW} delay time (fast page mode cycle only)	t_{CPWD}	70		ns	13
\overline{CAS} setup time for CAS-before-RAS refresh	t_{CSR}	10		ns	
\overline{CAS} hold time for CAS-before-RAS refresh	t_{CHR}	15		ns	
RAS precharge time to CAS active time	t_{RPC}	10		ns	
\overline{CAS} precharge time for CAS-before-RAS counter test	t_{CPT}	40		ns	
RAS hold time referenced to \overline{OE}	t_{ROH}	15		ns	
\overline{OE} access time	t_{OEA}		25	ns	9
\overline{OE} delay time	t_{OED}	15		ns	
\overline{OE} to output buffer turn-off delay time	$t_{O EZ}$	0	15	ns	10
\overline{OE} command hold time	$t_{OE H}$	20		ns	
Data input to \overline{CAS} delay time	t_{DZC}	0		ns	16
Data input to \overline{OE} delay time	t_{DZO}	0		ns	16
Masked write setup time	t_{MCS}	0		ns	
Masked write hold time referenced to RAS	t_{MRH}	0		ns	
Masked write hold time referenced to CAS	t_{MCH}	0		ns	

Input/Output Capacitance at $T_a = 25^\circ\text{C}$, $f = 1\text{ MHz}$, $V_{CC} = 5\text{ V} \pm 10\%$

Parameter	Symbol	min	max	Unit
Input capacitance (A_0 to A_7 , RAS, \overline{CAS} , \overline{UW} , \overline{LW} , \overline{OE})	C_{IN}		7	pF
I/O capacitance (I/O_1 to I/O_{16})	$C_{I/O}$		7	pF

-
- Notes:
- 6) After the power is turned on, 200 μ s are required after the arrival of V_{CC} stabilized current before memory is initialized and begins operation. In addition, before memory operation initializes, approximately 8 cycles worth of $\overline{\text{RAS}}$ dummy cycles are required. When the on-chip refresh counter is applied, approximately 8-cycles worth of $\overline{\text{CAS}}$ -before- $\overline{\text{RAS}}$ dummy cycles are required instead of the $\overline{\text{RAS}}$ dummy cycles.
 - 7) Measured at $t_T = 5$ ns.
 - 8) When measuring input signal timing, V_{IH} (min) and V_{IL} (max) are used for reference points. In addition, rise and fall time are defined between V_{IH} and V_{IL} .
 - 9) Measured using an equivalent of 50 pF and one standard TTL load.
 - 10) t_{OFF} (max) and t_{OEZ} (max) are defined as the time until output voltage can no longer be measured when output switches to a high impedance condition.
 - 11) Operation is guaranteed if either t_{RRH} or t_{RCH} are satisfied.
 - 12) These parameters are measured from the falling edge of $\overline{\text{CAS}}$ for an early-write cycle, and from the falling edge of UW and LW for a read-write/read-modify-write cycle.
 - 13) t_{WCS} , t_{CWD} , t_{RWD} , t_{AWD} and t_{CPWD} are not restrictive operating parameters for memory in that they specify the operating mode. If $t_{WCS} \geq t_{WCS}(\text{min})$, the cycle switches to an early-write cycle and output pins switch to high impedance throughout the cycle. If $t_{CWD} \geq t_{CWD}(\text{min})$, $t_{RWD} \geq t_{RWD}(\text{min})$, $t_{AWD} \geq t_{AWD}(\text{min})$ and $t_{CPWD} \geq t_{CPWD}(\text{min})$, the cycle switches to a read-write/read-modify-write cycle and data outputs equal information in the selected cells. If neither of the above conditions are satisfied, output pins are in an undefined state.
 - 14) $t_{RCD}(\text{max})$ does not indicate a restrictive operating parameter but instead represents the point at which the access time $t_{RAC}(\text{max})$ is guaranteed. If $t_{RCD} \geq t_{RCD}(\text{max})$, access time is determined according to t_{CAC} .
 - 15) $t_{RAD}(\text{max})$ does not indicate a restrictive operating parameter but instead represents the point at which the access time $t_{RAC}(\text{max})$ is guaranteed. If $t_{RAD} \geq t_{RAD}(\text{max})$, access time is determined according to t_{AA} .
 - 16) Operation is guaranteed if either t_{DZC} or t_{DZO} are satisfied.

Timing Chart
Read Cycle

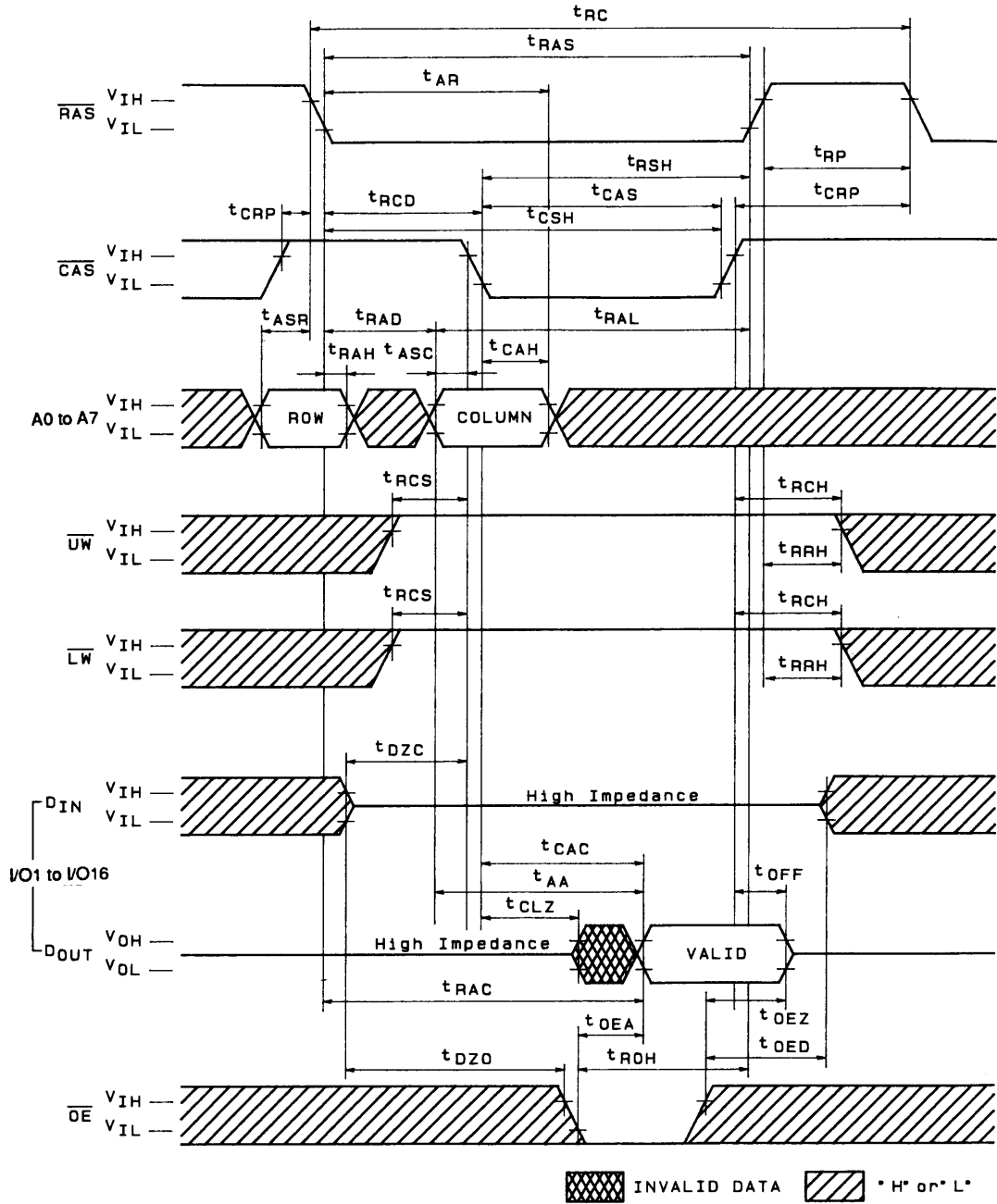

A02139

Early Write Cycle

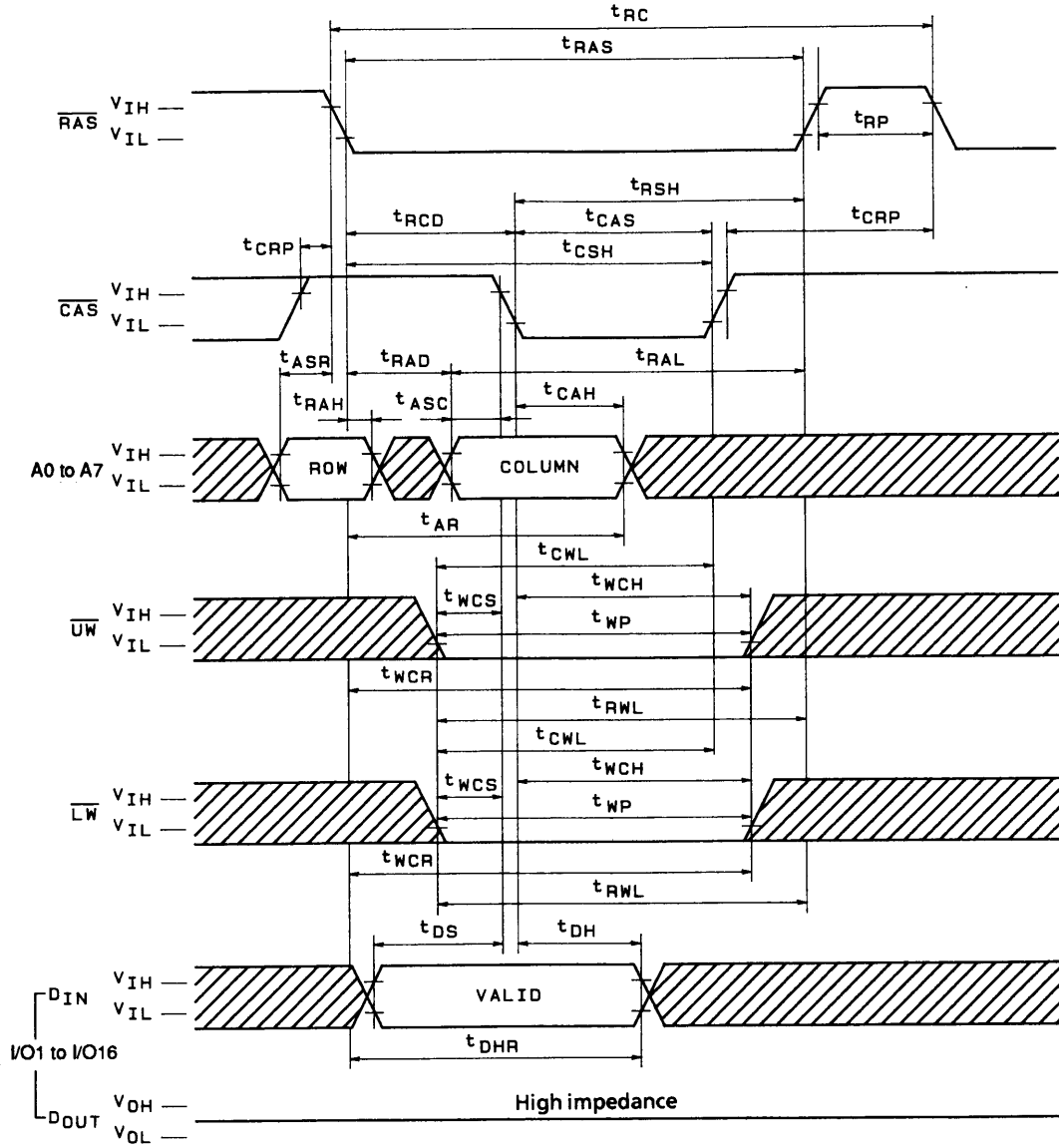

* H* or L*

\overline{OE} : * H* or L*

A02140

Upper Byte Early Write Cycle

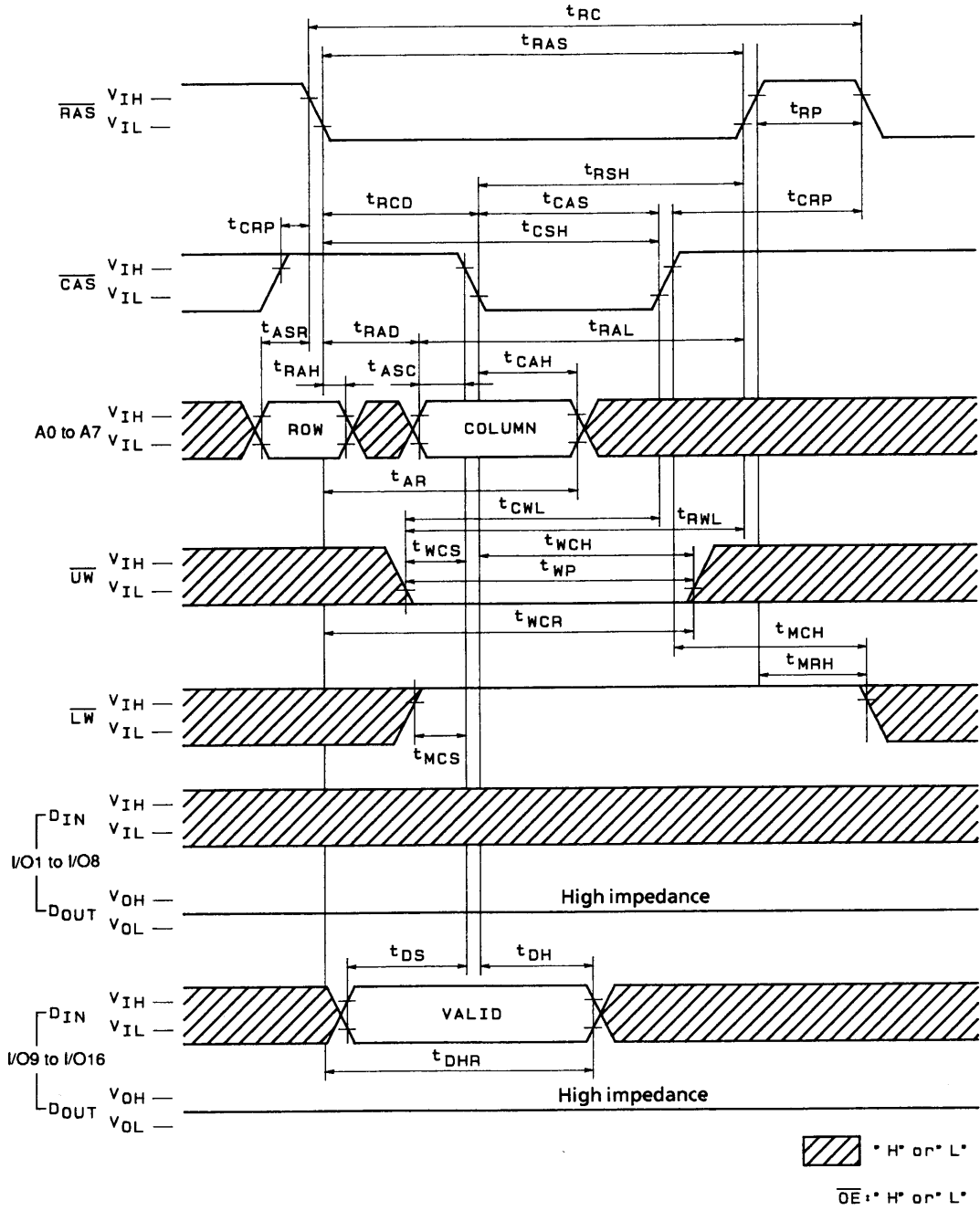

A02141

Lower Byte Early Write Cycle

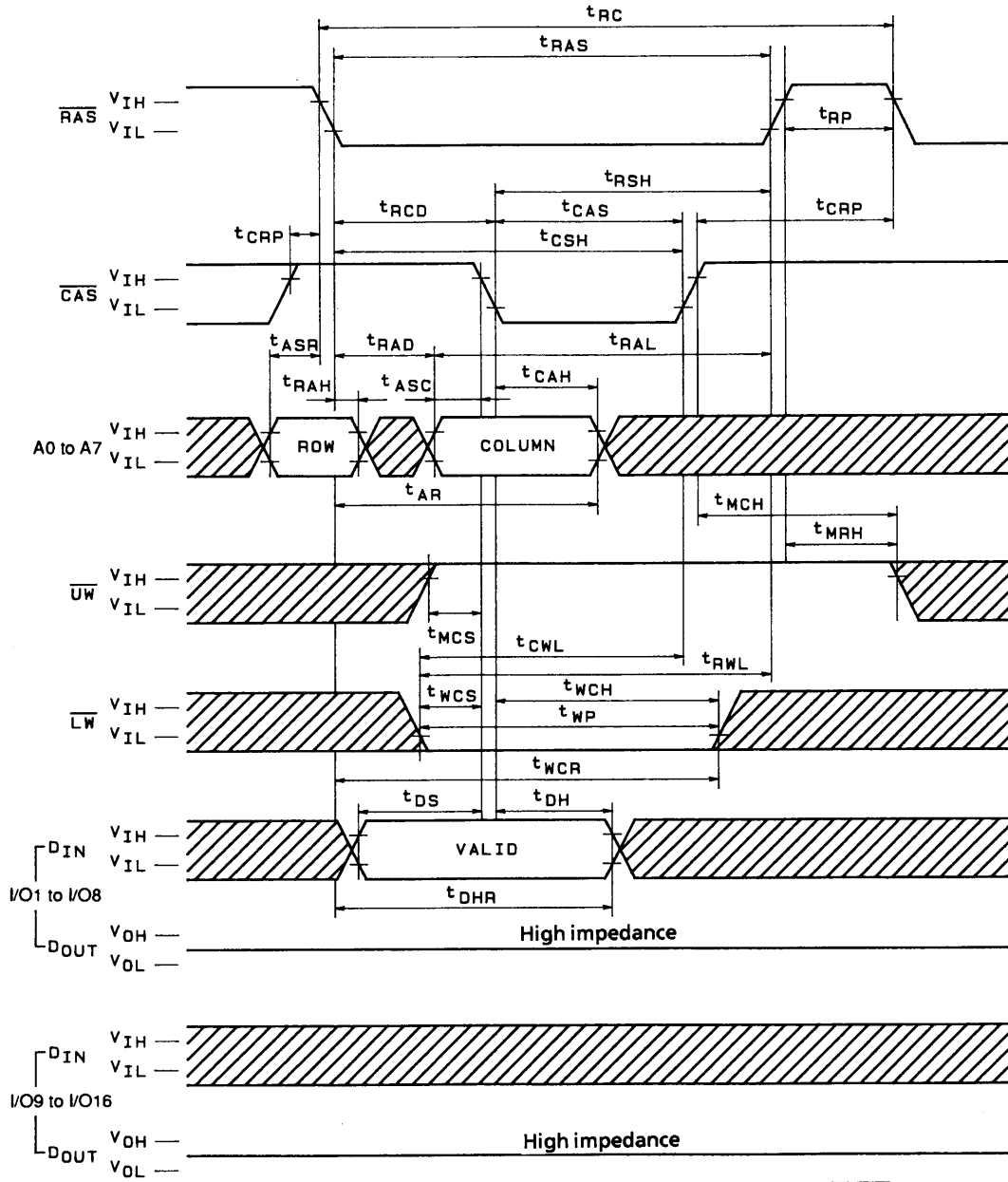

Hatched box * V_{IH} or V_{OL}

White box * V_{IL} or V_{OH}

A02142

Write Cycle (OE Control)

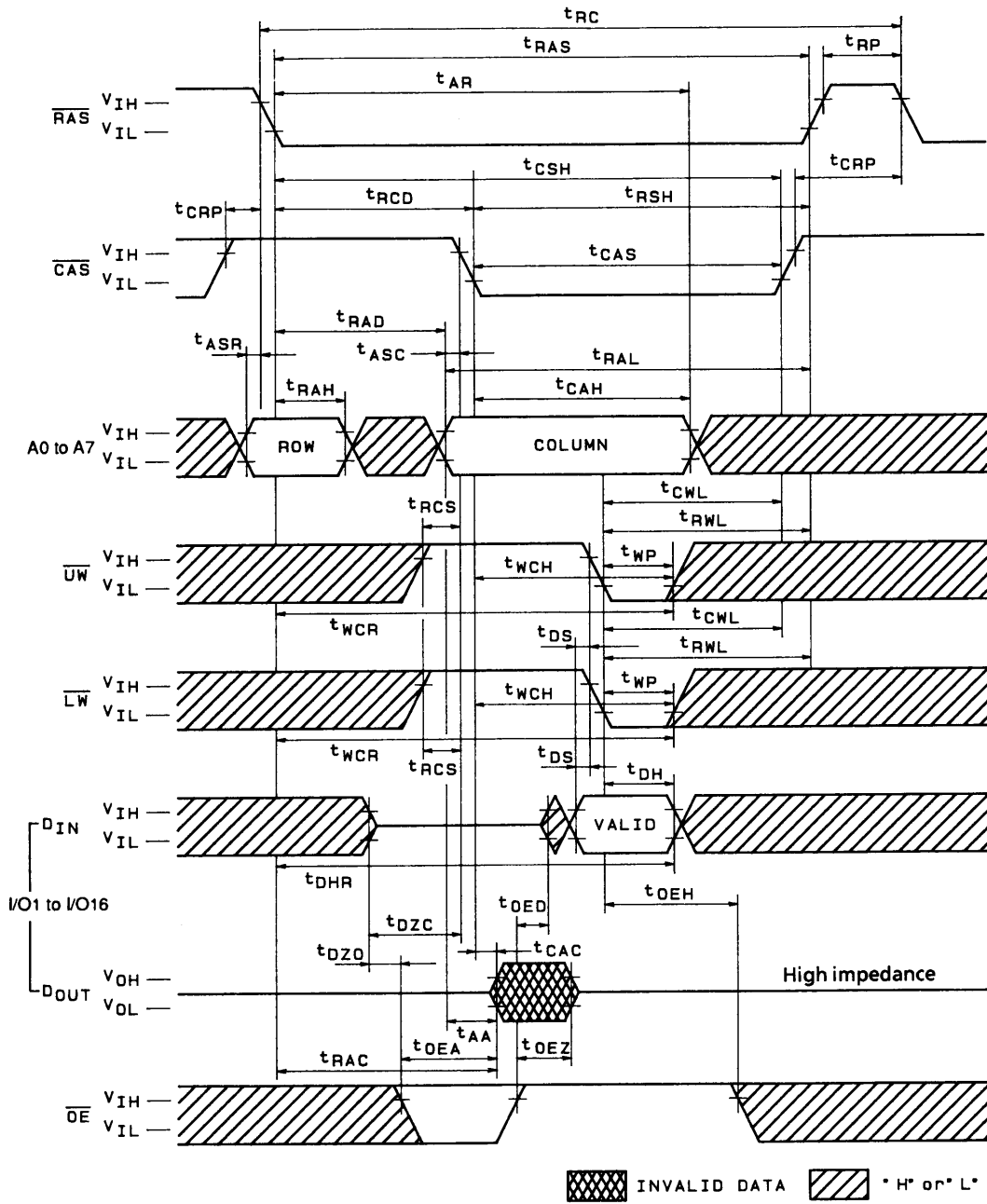

A02143

Upper Byte Write Cycle ($\overline{\text{OE}}$ Control)

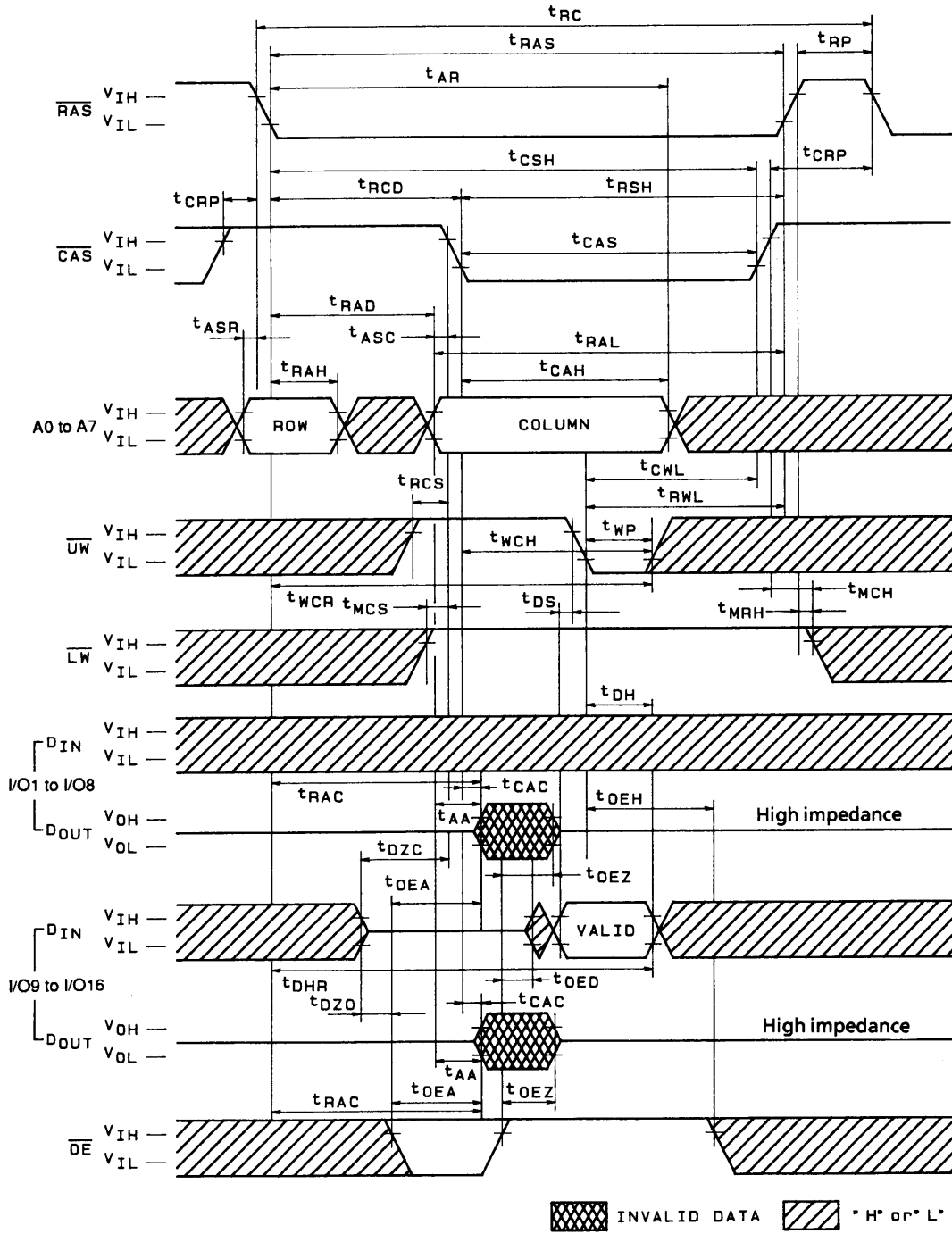

A02144

Lower Byte Write Cycle ($\overline{\text{OE}}$ Control)

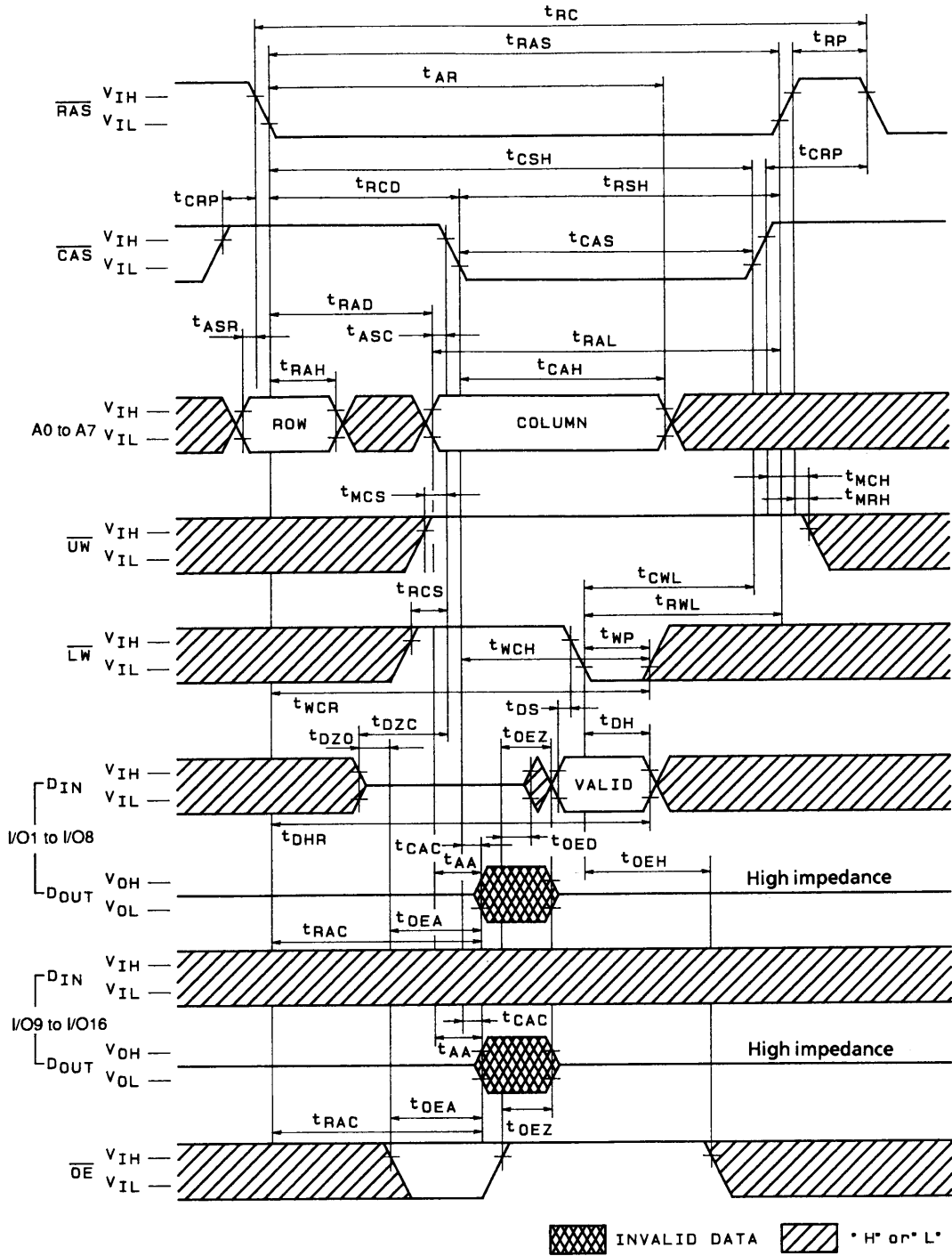

A02145

Read-Modify-Write Cycle

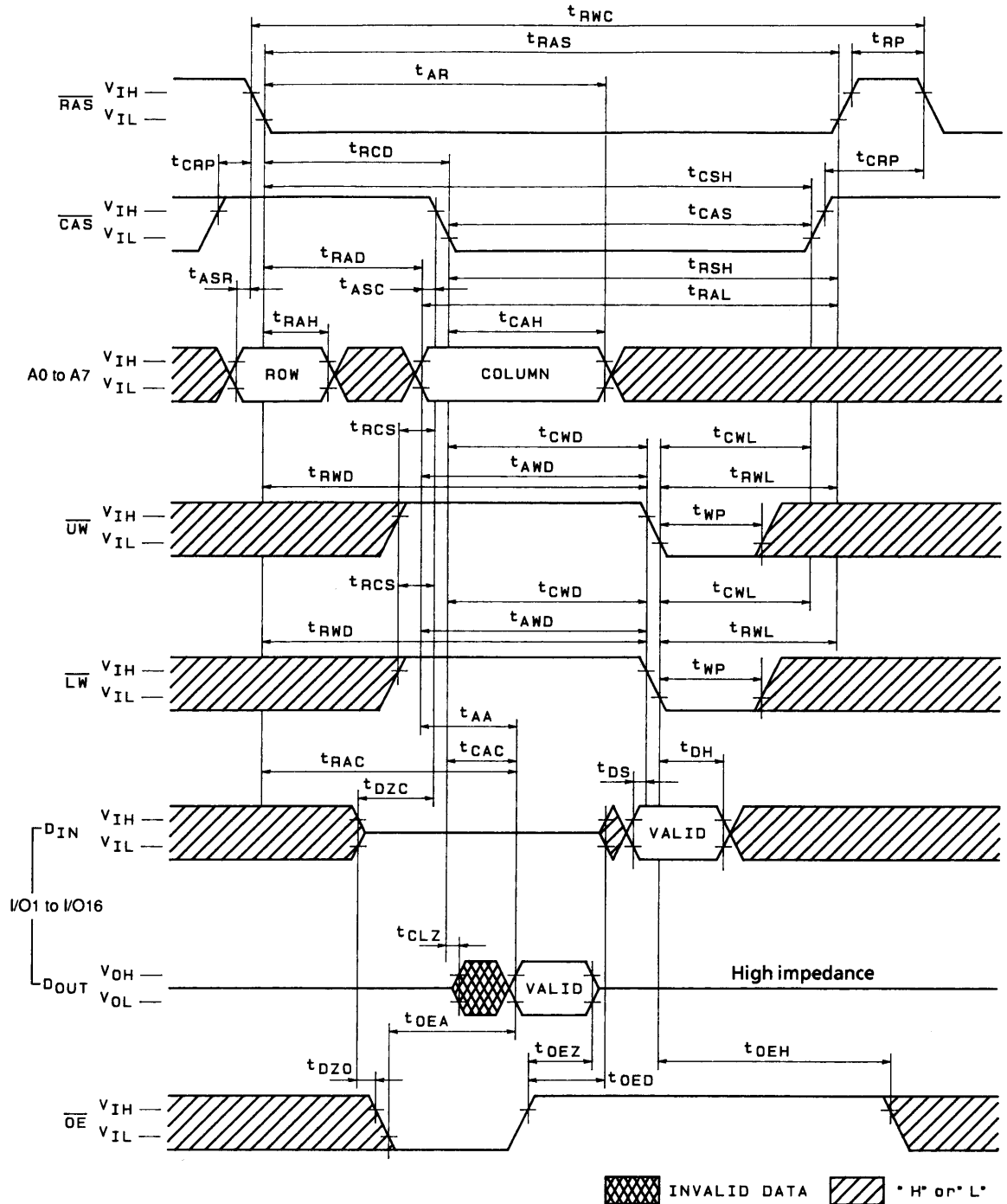

A02146

Read-Modify Upper Byte Write Cycle

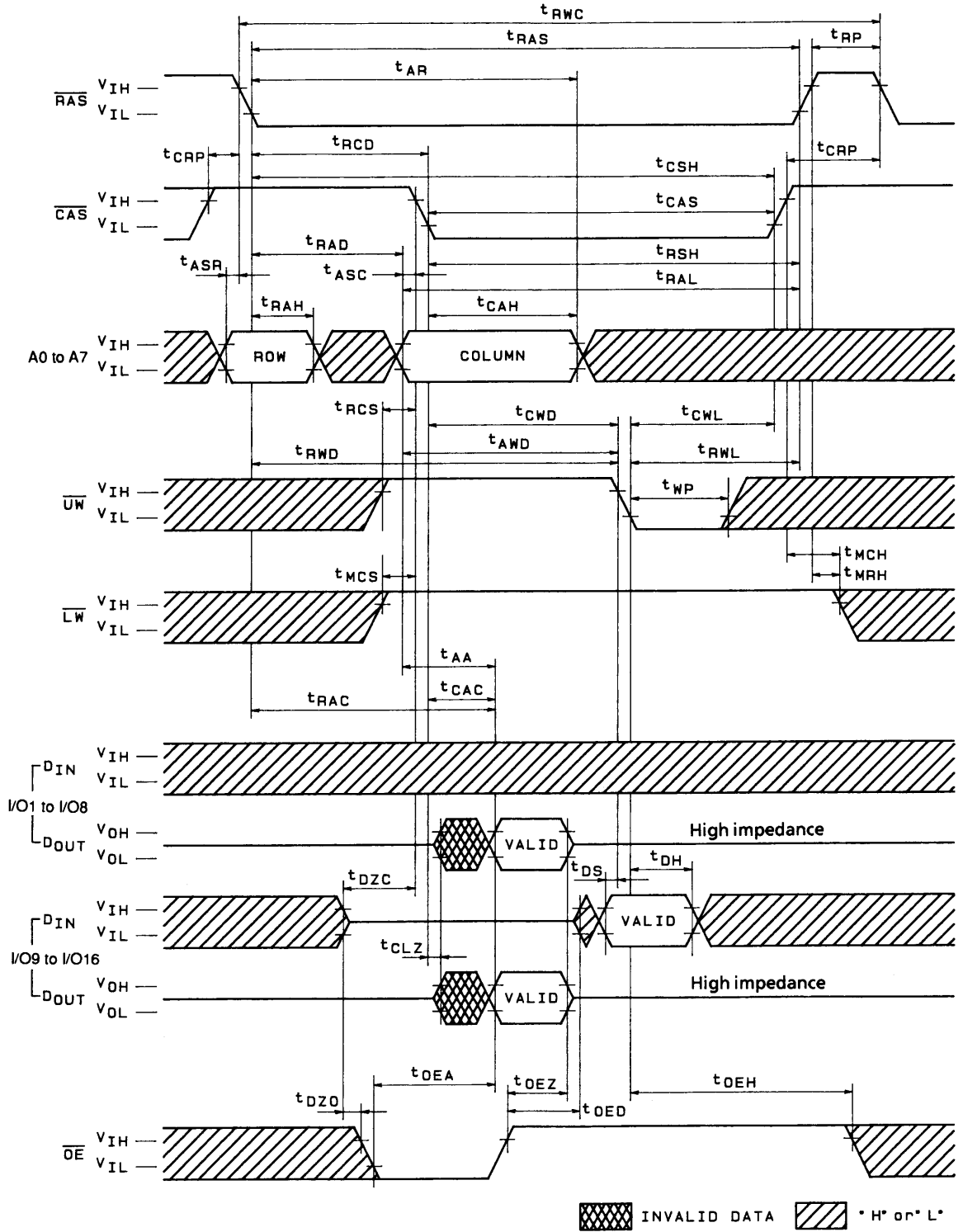

A02147

Fast Page Mode Early Write Cycle

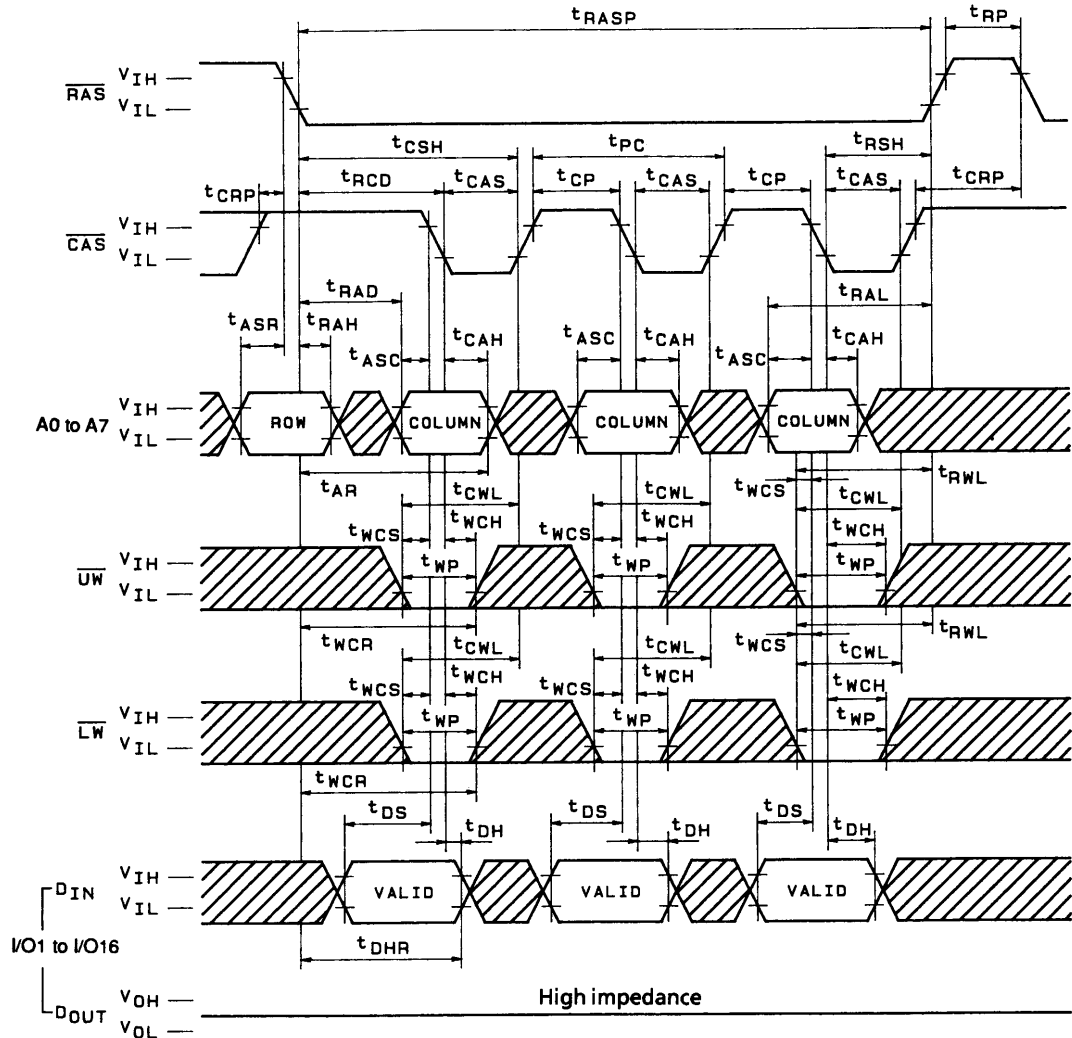

A02150

Fast Page Mode Upper Byte Early Write Cycle

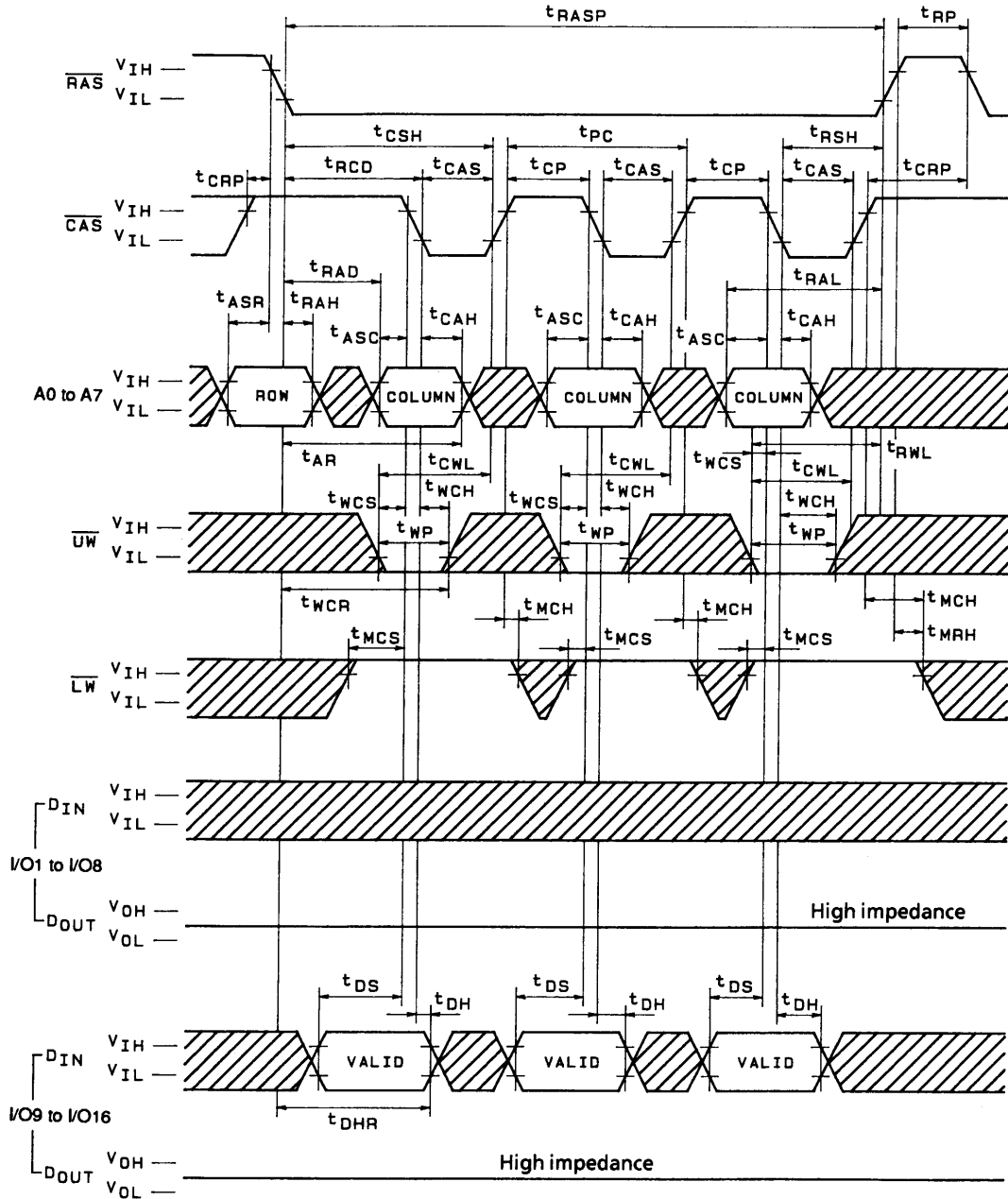

A02151

Fast Page Mode Lower Byte Early Write Cycle

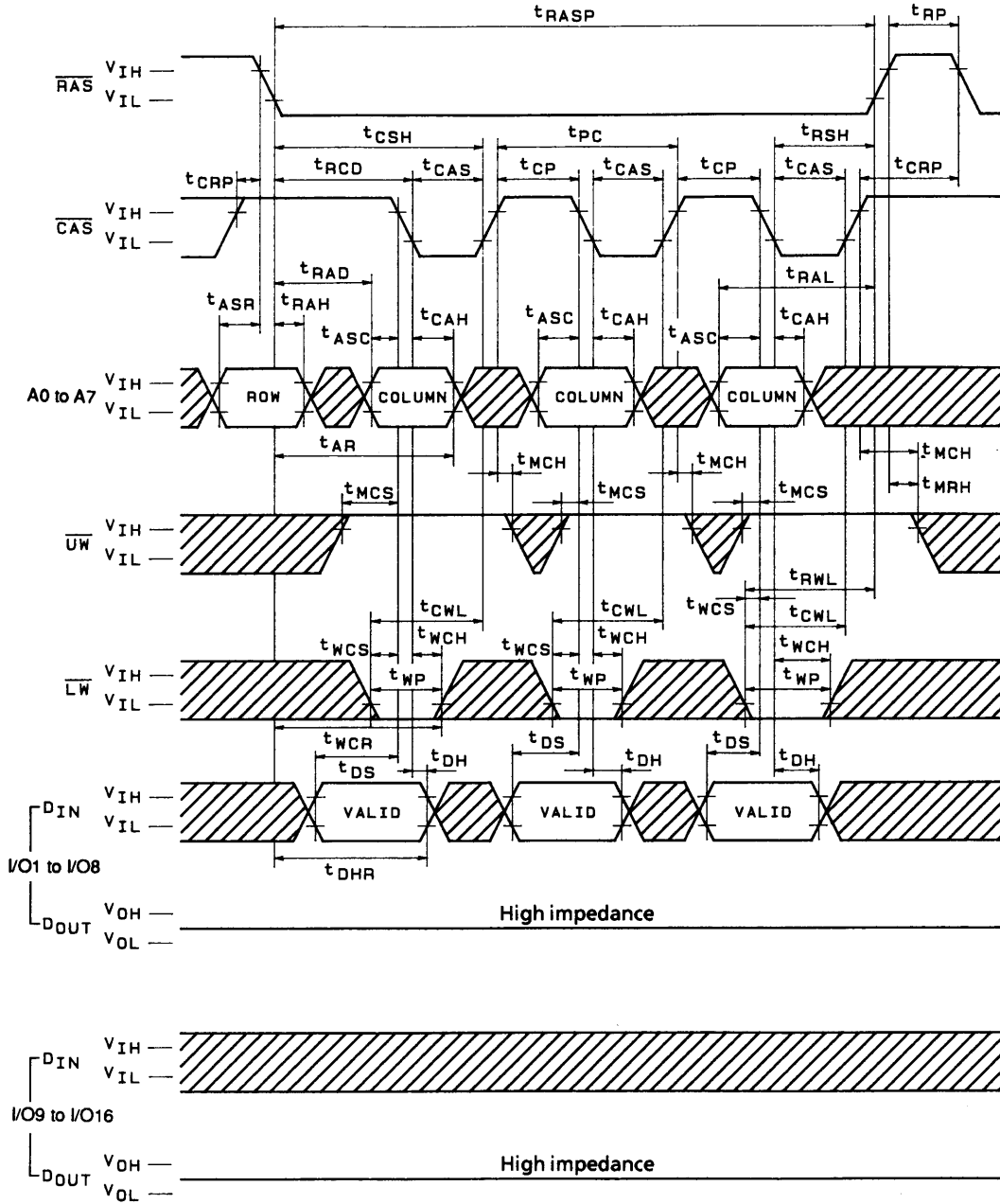

A02152

Hidden Refresh Cycle

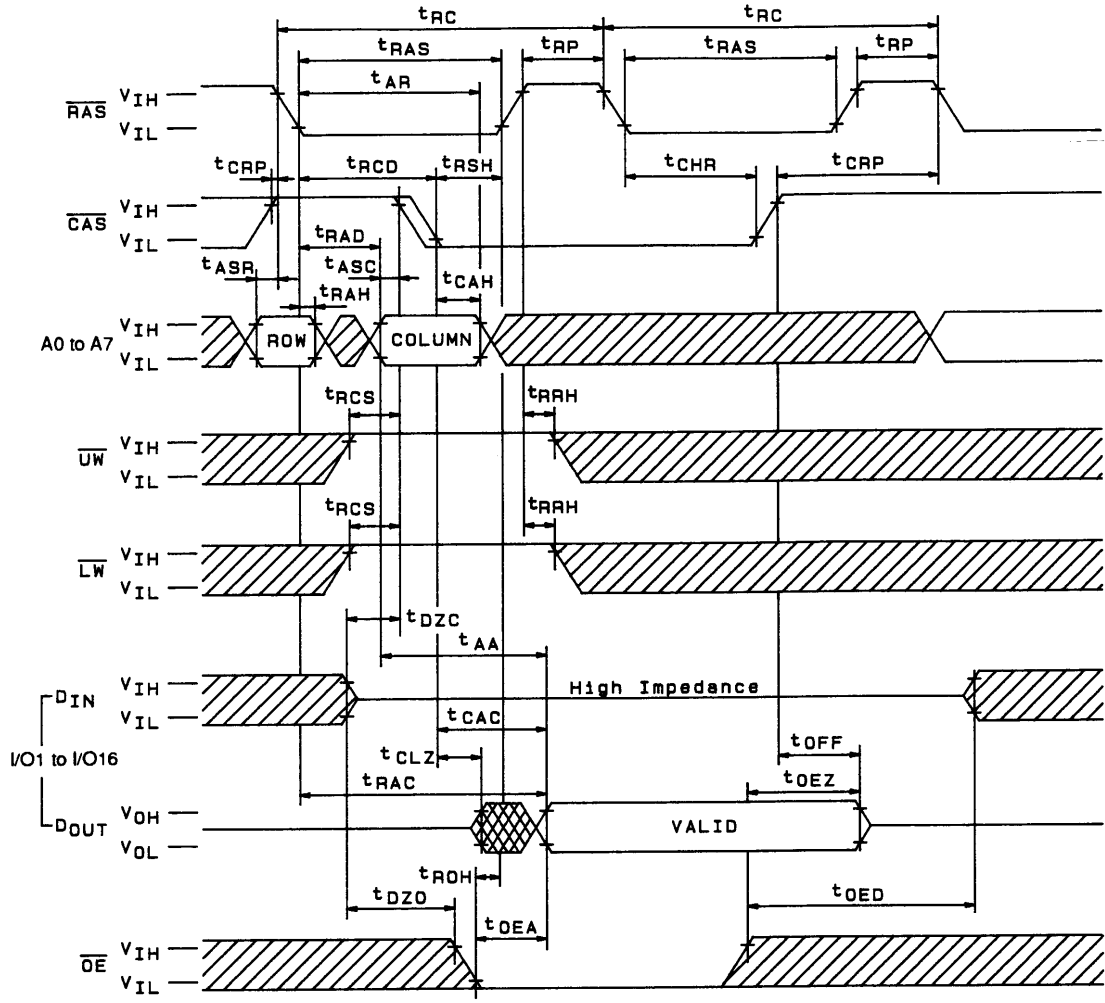

A03280
A03476

RAS-Only Refresh Cycle

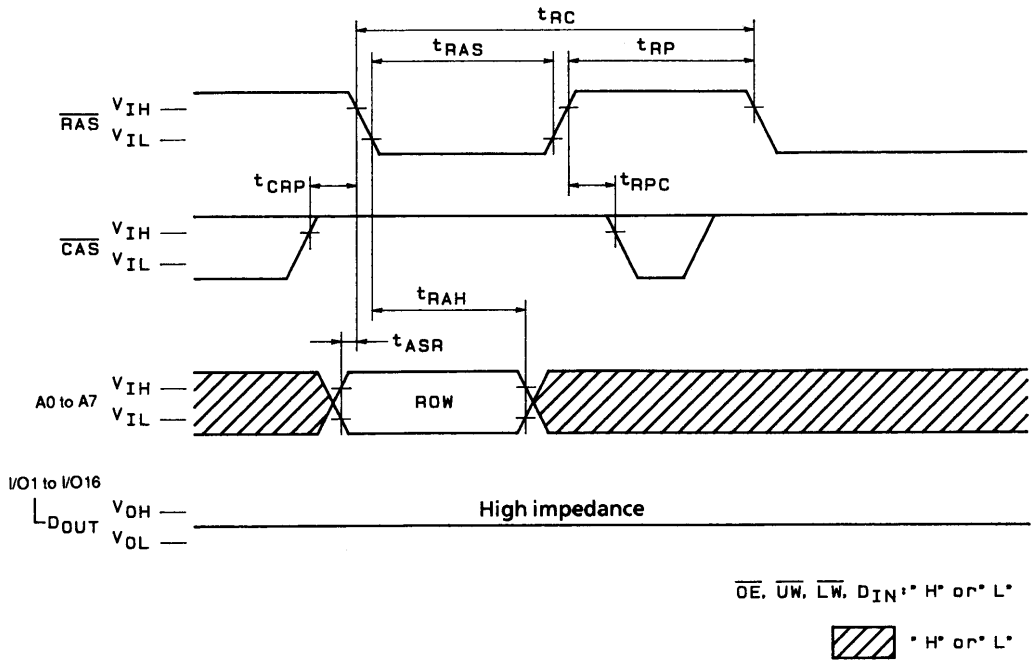

A02157

CAS-Before-RAS Refresh Cycle

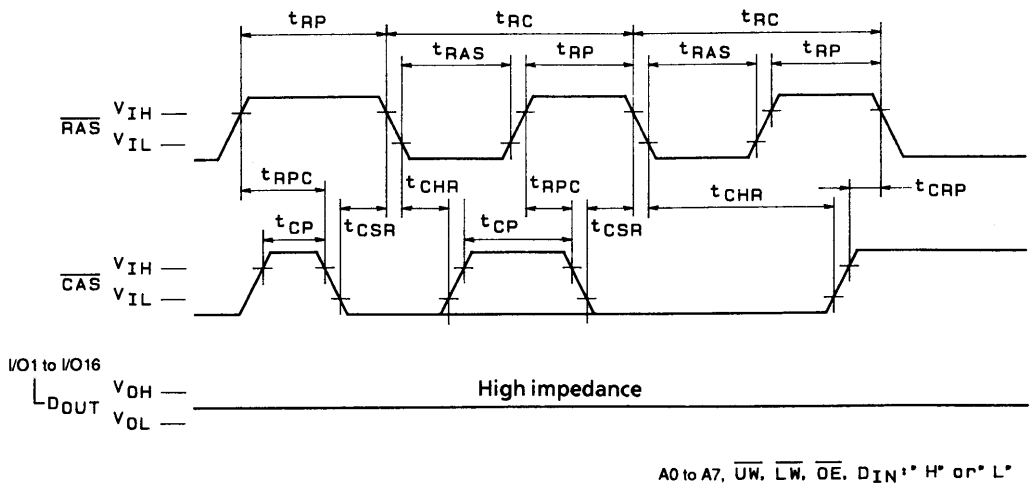

A02158

CAS-Before-RAS Refresh Counter Test Cycle (read)

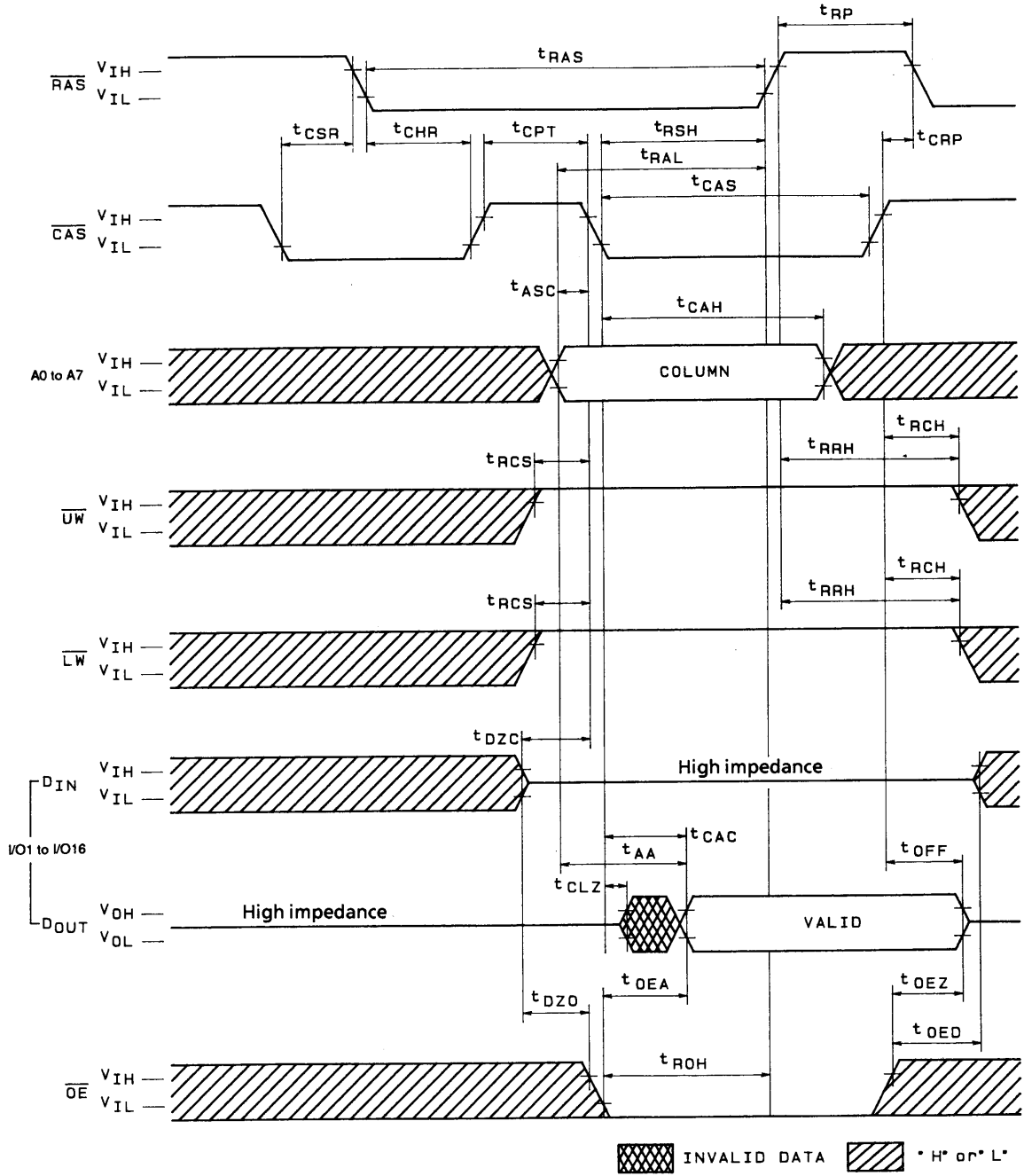

A02159

CAS-Before-RAS Refresh Counter Test Cycle (write)

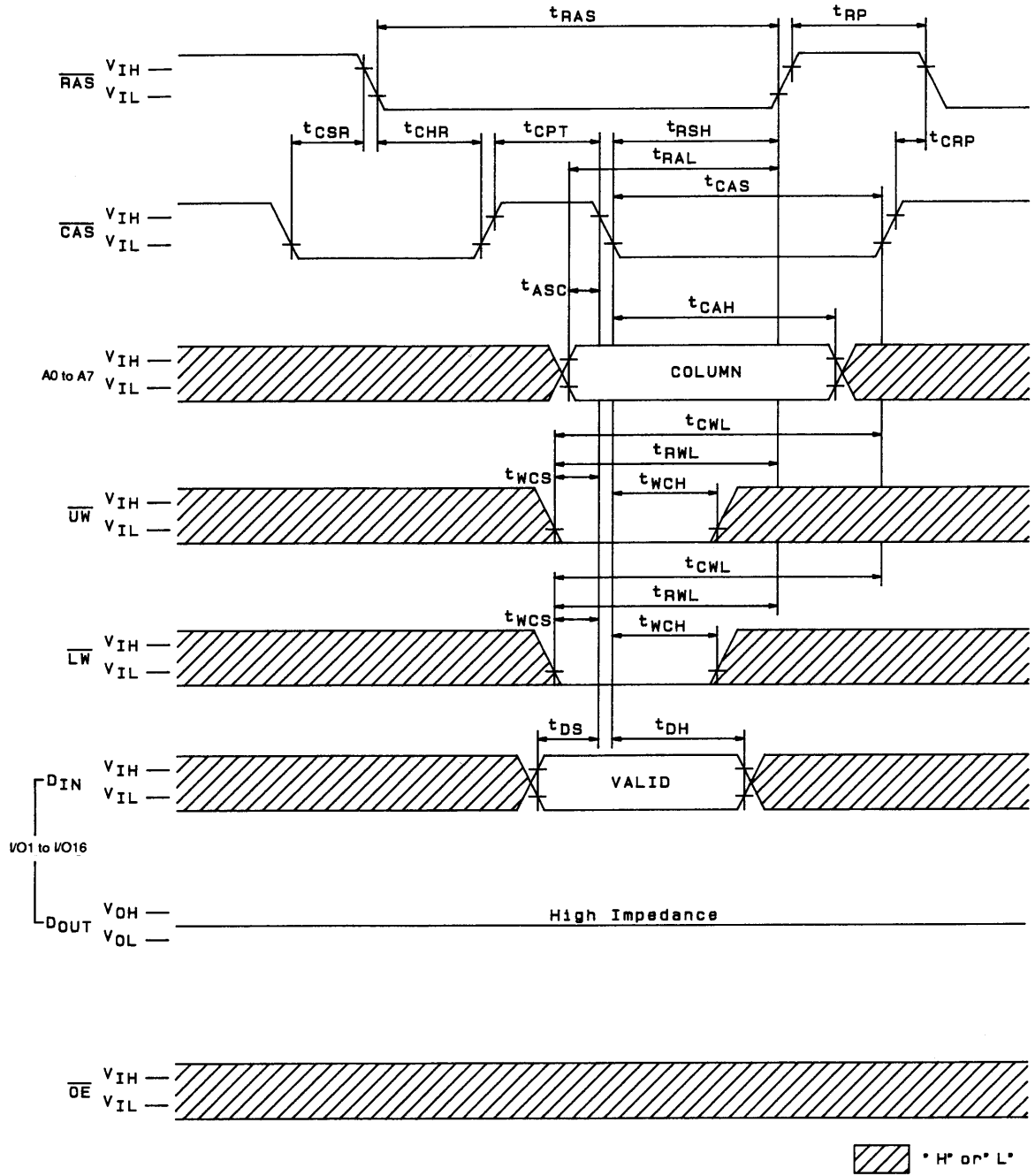

A02160
A03477

CAS-Before-RAS Refresh Counter Test Cycle (read-modify-write)

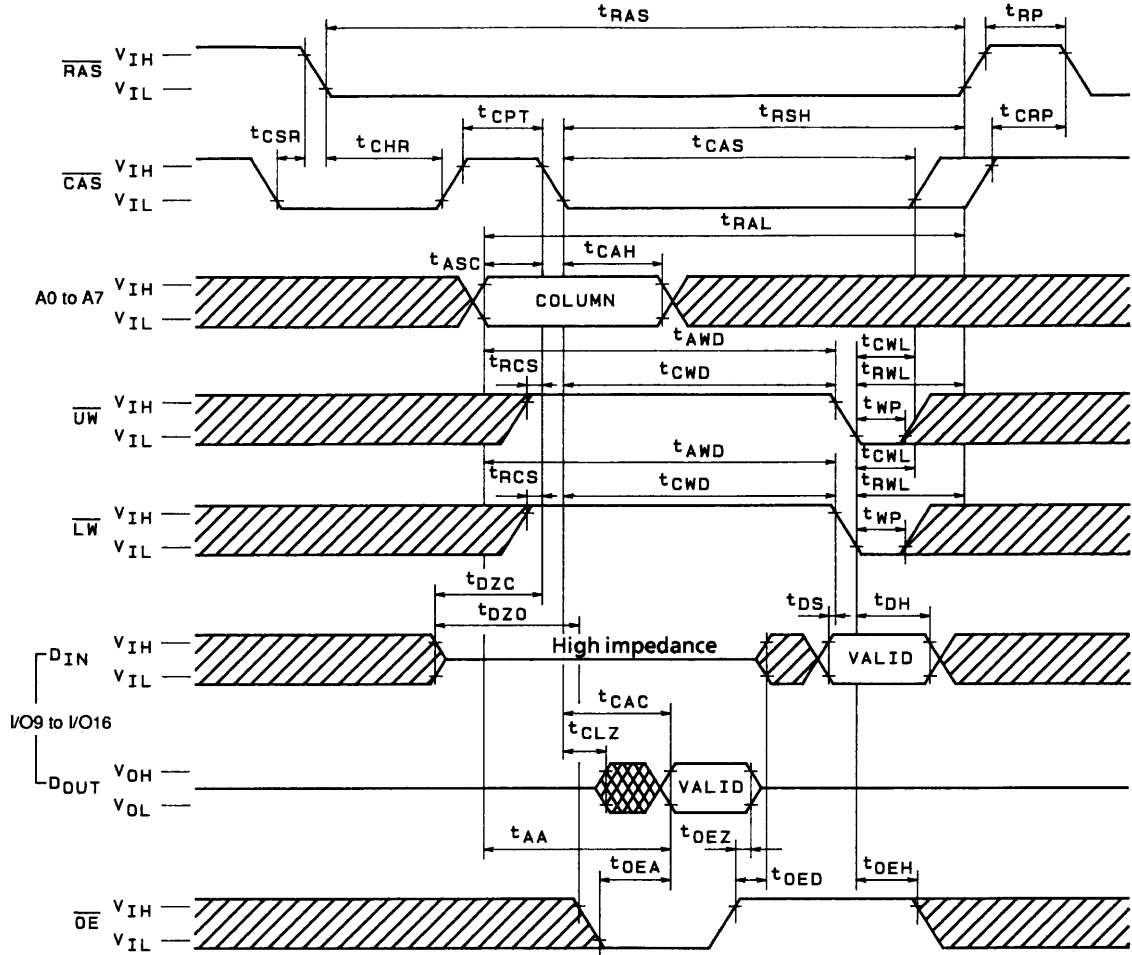

INVALID DATA *H* or *L*

A02161

- No products described or contained herein are intended for use in surgical implants, life-support systems, aerospace equipment, nuclear power control systems, vehicles, disaster/crime-prevention equipment and the like, the failure of which may directly or indirectly cause injury, death or property loss.
- Anyone purchasing any products described or contained herein for an above-mentioned use shall:
 - ① Accept full responsibility and indemnify and defend SANYO ELECTRIC CO., LTD., its affiliates, subsidiaries and distributors and all their officers and employees, jointly and severally, against any and all claims and litigation and all damages, cost and expenses associated with such use:
 - ② Not impose any responsibility for any fault or negligence which may be cited in any such claim or litigation on SANYO ELECTRIC CO., LTD., its affiliates, subsidiaries and distributors or any of their officers and employees jointly or severally.
- Information (including circuit diagrams and circuit parameters) herein is for example only; it is not guaranteed for volume production. SANYO believes information herein is accurate and reliable, but no guarantees are made or implied regarding its use or any infringements of intellectual property rights or other rights of third parties.

This catalog provides information as of March 1996. Specifications and information herein are subject to change without notice.