



# LC89585

## CD Encoder LSI for CD-R Systems

### Overview

The LC89585 is an LSI that implements the digital processing required for CD-R recording in conformance with the orange book specifications. The LC89585 adds subcode data to record data processed by an A/D converter and the built-in DIR (digital audio interface receiver), FS decoder, and CD decoder circuits, and converts that data to CIRC (cross-interleave reed-solomon code) data. The LC89585 then performs EFM (eight-to-fourteen modulation encoding) conversion in real time.

### Features

- A/D converter clock generation
- Built-in DIR (conforming to the IEC958 standard) and DIT (Digital audio interface transmitter)
- Built-in fader and muting circuits
- On-chip buffer RAM for encoder processing
- Automatic linking position processing function
- CCB CPU interface

### Package Dimensions

unit: mm

3151-QFP100E

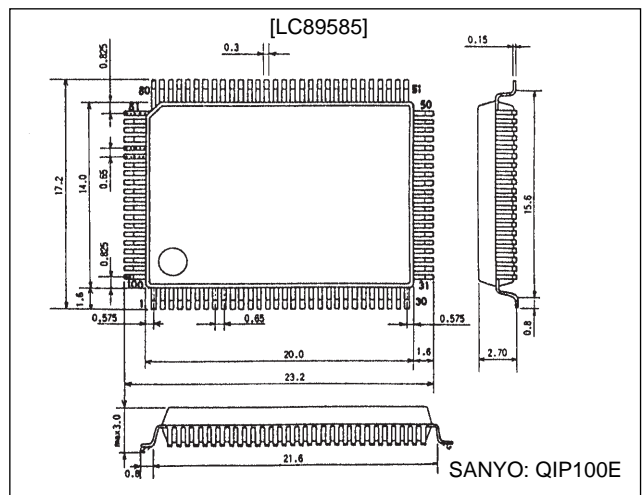

### Specifications

#### Absolute Maximum Ratings at $V_{SS} = 0$ V

Parameter	Symbol	Conditions	Ratings	Unit
Maximum supply voltage	$V_{DD \max}$	$T_a = 25^\circ\text{C}$	-0.3 to +7.0	V
I/O voltages	$V_I, V_O$	$T_a = 25^\circ\text{C}$	-0.3 to $V_{DD} + 0.3$	V
Operating temperature	$T_{opr}$		-30 to +70	$^\circ\text{C}$
Storage temperature	$T_{stg}$		-55 to +125	$^\circ\text{C}$
Soldering temperature resistance		10 seconds (pins only)	260	$^\circ\text{C}$

#### Allowable Operating Ranges at $T_a = -30$ to $+70^\circ\text{C}$ , $V_{SS} = 0$ V

Parameter	Symbol	Conditions	min	typ	max	Unit
Supply voltage	$V_{DD}$		4.5	—	5.5	V
Input voltage	$V_{IN}$		0	—	$V_{DD}$	V

## LC89585

### DC Electrical Characteristics at $T_a = -30$ to $+70^\circ\text{C}$ , $V_{DD} = 4.5$ to $5.5$ V, $V_{SS} = 0$ V

Parameter	Symbol	Conditions	min	typ	max	Unit
High-level input voltage	$V_{IH1}$	*1	2.2	—	$V_{DD} + 0.3$	V
Low-level input voltage	$V_{IL1}$	*1	-0.3	—	+0.8	V
High-level input voltage	$V_{IH2}$	*2	$0.7 V_{DD}$	—	$V_{DD} + 0.3$	V
Low-level input voltage	$V_{IL2}$	*2	-0.3	—	$0.3 V_{DD}$	V
High-level input voltage	$V_{IH3}$	*3	$0.8 V_{DD}$	—	$V_{DD} + 0.3$	V
Low-level input voltage	$V_{IL3}$	*3	-0.3	—	$0.2 V_{DD}$	V
High-level output voltage	$V_{OH1}$	$I_{OH} = -1 \mu\text{A}$ , *4	$V_{DD} - 0.05$	—	—	V
Low-level output voltage	$V_{OL1}$	$I_{OL} = +1 \mu\text{A}$ , *4	—	—	$V_{SS} + 0.05$	V
High-level output voltage	$V_{OH2}$	$I_{OH} = -20 \mu\text{A}$ , *5	$V_{DD} - 0.05$	—	—	V
Low-level output voltage	$V_{OL2}$	$I_{OL} = +20 \mu\text{A}$ , *5	—	—	$V_{SS} + 0.05$	V

- Note: 1. The DIN1 to DIN4, ENCVCOIN, JITVCOIN, A0 to A9, DQ1 to DQ4,  $\overline{\text{RAS}}$ ,  $\overline{\text{CAS}}$ ,  $\overline{\text{OE}}$  and  $\overline{\text{WR}}$  input pins.  
 2. Input pins other than DIN1 to DIN4, ENCVCOIN, JITVCOIN, A0 to A9, DQ1 to DQ4,  $\overline{\text{RAS}}$ ,  $\overline{\text{CAS}}$ ,  $\overline{\text{OE}}$ ,  $\overline{\text{WR}}$ ,  $\overline{\text{RESET}}$ , CCB, CE, CL, DI, DIRRC1 and XTALIN.  
 3. The  $\overline{\text{RESET}}$ , CCB, CE, CL, DI, DIRRC1 and XTALIN input pins.  
 4. Output pins other than JITLPFO and ENCLPFO.  
 5. The JITLPFO and ENCLPFO output pins.

### Pin Assignment

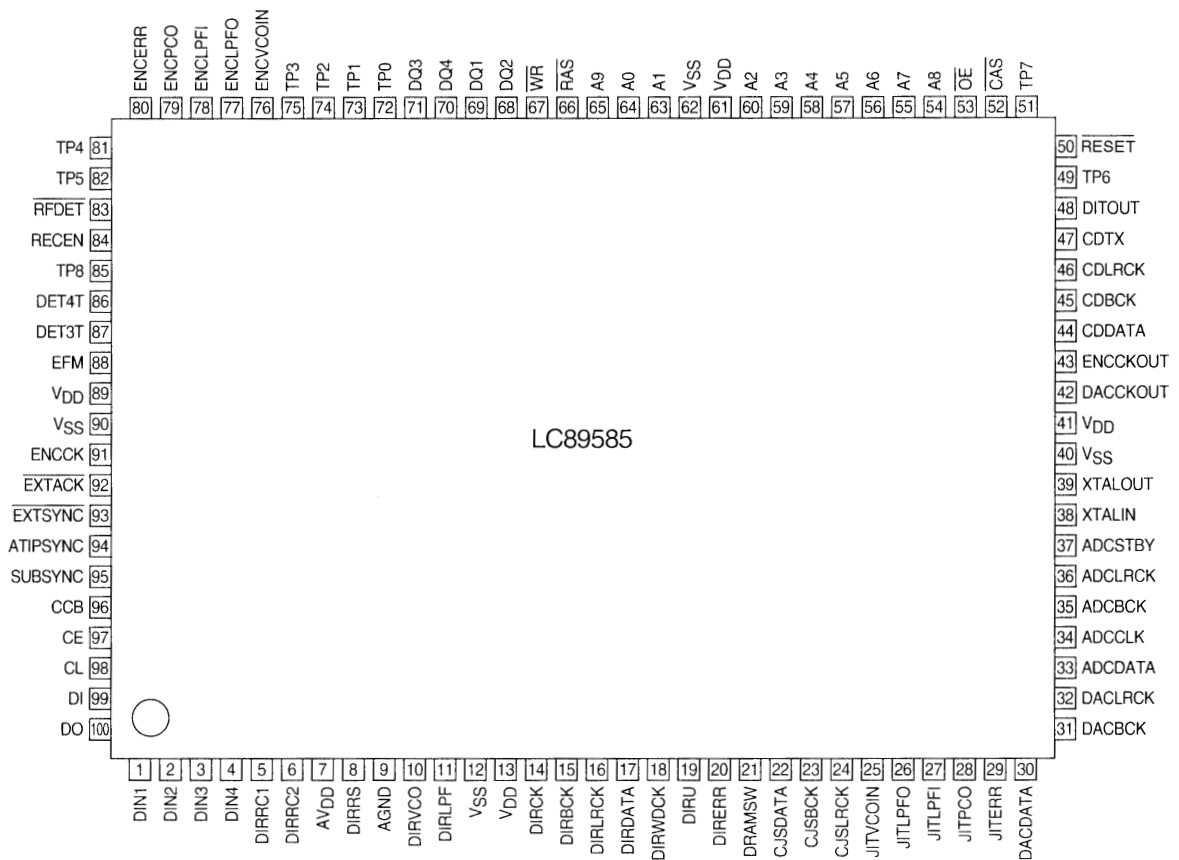

A09787

Top view

System Block Diagram

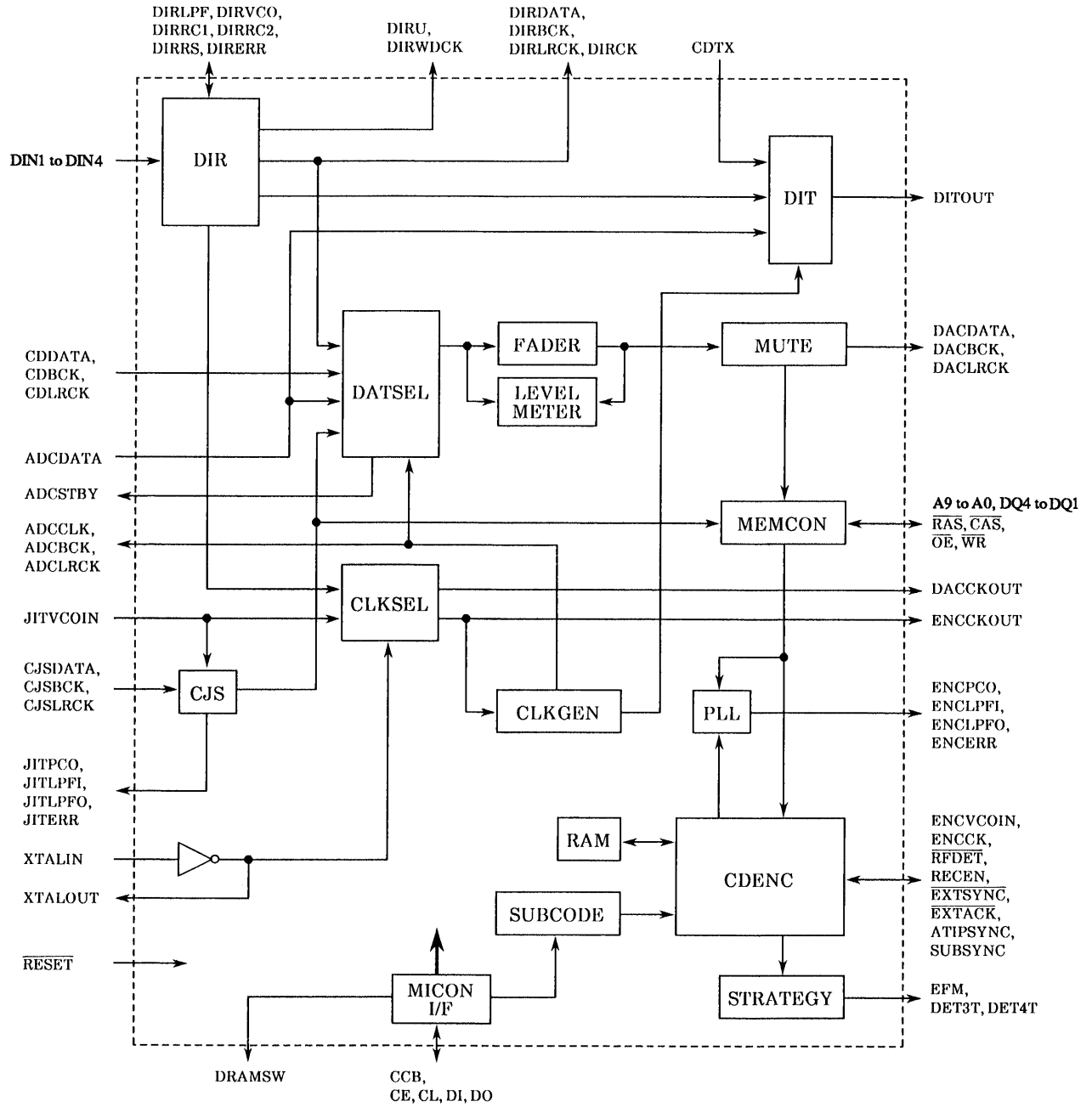

## LC89585

### Pin Functions

Pin No.	Symbol	I/O	Function
1	DIN1	I	Optical module data input
2	DIN2	I	Optical module data input
3	DIN3	I	Optical module data input
4	DIN4	I	Optical module data input
5	DIRRC1	I	RC oscillator input
6	DIRRC2	O	RC oscillator output
7	AV <sub>DD</sub>	—	Analog system power supply
8	DIRRS	I	VCO oscillation band adjustment input
9	AGND	—	Analog system ground
10	DIRVCO	I	VCO free-running frequency setting input
11	DIRLPF	O	PLL low-pass filter connection
12	V <sub>SS</sub>	—	Ground
13	V <sub>DD</sub>	—	+5 V power supply
14	DIRCK	O	DIR system clock output
15	DIRBCK	O	DIR bit clock output
16	DIRLRCK	O	DIR L/R clock output
17	DIRDATA	O	DIR demodulated data output
18	DIRWDCK	O	DIR word clock output
19	DIRU	O	U-bit output
20	DIRERR	O	Data error and lock state monitor output
21	DRAMSW	O	External DRAM capacity setting output
22	CJSDATA	I	Clock jitter sub-laser data input
23	CJSBCK	I	Clock jitter sub-laser bit clock input
24	CJSLRCK	I	Clock jitter sub-laser L/R clock input
25	JITVCOIN	I	VCO input
26	JITLPFO	O	Low-pass filter output
27	JITLPFI	I	Low-pass filter input
28	JITPCO	O	Phase comparator output
29	JITERR	O	Lock state monitor output
30	DACDATA	O	D/A converter data output
31	DACBCK	O	D/A converter bit clock output
32	DACLCK	O	D/A converter L/R clock output
33	ADCDATA	I	A/D converter record data input
34	ADCCLK	O	A/D converter clock output
35	ADCBCK	O	A/D converter bit clock output
36	ADCLRCK	O	A/D converter L/R clock output
37	ADCSTBY	O	A/D converter standby signal output
38	XTALIN	I	System clock input
39	XTALOUT	O	System clock output
40	V <sub>SS</sub>	—	Ground
41	V <sub>DD</sub>	—	+5 V power supply
42	DACCKOUT	O	D/A converter system clock output
43	ENCKOUT	O	CD decoder system clock output
44	CDDATA	I	CD decoder data input
45	CDBCK	I	CD decoder bit clock input
46	CDLRCK	I	CD decoder L/R clock input
47	CDTX	I	Signal input from the CD decoder output
48	DITOUT	O	Biphase modulation output
49	TP6	I	Test pin
50	RESET	I	System reset input

Continued on next page.

## LC89585

Continued from preceding page.

Pin No.	Symbol	I/O	Function
51	TP7	I	Test pin
52	$\overline{\text{CAS}}$	O	DRAM column address strobe signal output
53	$\overline{\text{OE}}$	O	DRAM output enable signal output
54	A8	O	DRAM address outputs
55	A7	O	
56	A6	O	
57	A5	O	
58	A4	O	
59	A3	O	
60	A2	O	
61	V <sub>DD</sub>	—	+5 V power supply
62	V <sub>SS</sub>	—	Ground
63	A1	O	DRAM address outputs
64	A0	O	
65	A9	O	
66	$\overline{\text{RAS}}$	O	DRAM row address strobe signal output
67	$\overline{\text{WR}}$	O	DRAM read/write signal output
68	DQ2	I/O	DRAM data I/O
69	DQ1	I/O	
70	DQ4	I/O	
71	DQ3	I/O	
72	TP0	I	Test pin
73	TP1	I	
74	TP2	I	
75	TP3	O	
76	ENCVCOIN	I	Encoder circuit clock input
77	ENCLPFO	O	Low-pass filter output
78	ENCLPFI	I	Low-pass filter input
79	ENCPCO	O	Phase comparator output
80	ENCERR	O	Lock state monitor output
81	TP4	O	Test pin
82	TP5	I	
83	$\overline{\text{RFDET}}$	I	RF signal input
84	RECEN	I	Record enable signal input
85	TP8	O	Test pin
86	DET4T	O	4T detection signal output
87	DET3T	O	3T detection signal output
88	EFM	O	EFM signal output
89	V <sub>DD</sub>	—	+5 V power supply
90	V <sub>SS</sub>	—	Ground
91	ENCCK	O	Encoder clock output
92	$\overline{\text{EXTACK}}$	O	ATIP synchronization reporting signal output
93	$\overline{\text{EXTSYNC}}$	I	ATIP synchronization enable signal input
94	ATIPSYNC	I	ATIP synchronization signal input
95	SUBSYNC	O	Subcode synchronization signal output
96	CCB	I	CPU interface type switching signal input
97	CE	I	CPU interface chip enable signal input
98	CL	I	CPU interface data transfer clock input
99	DI	I	CPU interface data input
100	DO	O	CPU interface data output

- No products described or contained herein are intended for use in surgical implants, life-support systems, aerospace equipment, nuclear power control systems, vehicles, disaster/crime-prevention equipment and the like, the failure of which may directly or indirectly cause injury, death or property loss.
- Anyone purchasing any products described or contained herein for an above-mentioned use shall:
  - ① Accept full responsibility and indemnify and defend SANYO ELECTRIC CO., LTD., its affiliates, subsidiaries and distributors and all their officers and employees, jointly and severally, against any and all claims and litigation and all damages, cost and expenses associated with such use:
  - ② Not impose any responsibility for any fault or negligence which may be cited in any such claim or litigation on SANYO ELECTRIC CO., LTD., its affiliates, subsidiaries and distributors or any of their officers and employees jointly or severally.
- Information (including circuit diagrams and circuit parameters) herein is for example only; it is not guaranteed for volume production. SANYO believes information herein is accurate and reliable, but no guarantees are made or implied regarding its use or any infringements of intellectual property rights or other rights of third parties.

This catalog provides information as of January, 1998. Specifications and information herein are subject to change without notice.