



LC78833M, 78833V

Digital Audio 16-Bit D/A Converter with Built-In Digital Filters

Preliminary

Overview

The LC78833M and LC78833V are CMOS 16-bit D/A converters with built-in 4× oversampling digital filters.

Functions and Features

[Digital Filter Block]

- 4× oversampling filters: Two FIR filter stages (33rd and ninth order)
- De-emphasis filter: Supports a 44.1 kHz sampling frequency (fs).

[D/A Converter Block]

- Dynamic level shifting conversion 16-bit D/A converter
- D/A converters for two channels (synchronized outputs) on a single chip
- On-chip output operational amplifiers
- System clock: 384fs
- 5-V single-voltage power supply
- Supports low-voltage operation (3.0 V)
- Implemented in a Si gate CMOS process for low power.

Package Dimensions

unit: mm

3036B-MFP20

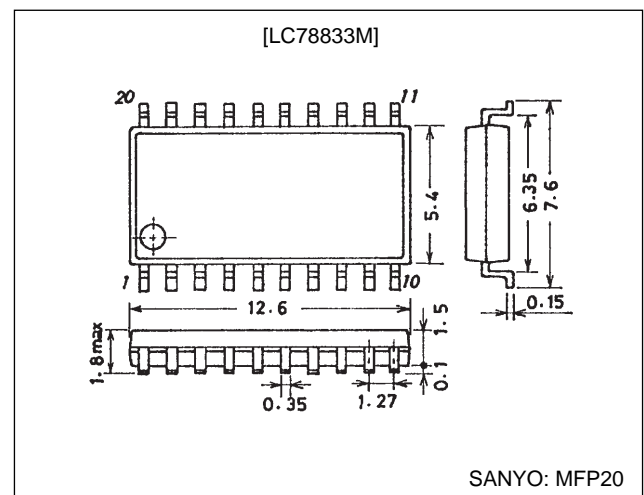

unit: mm

3175A-SSOP24

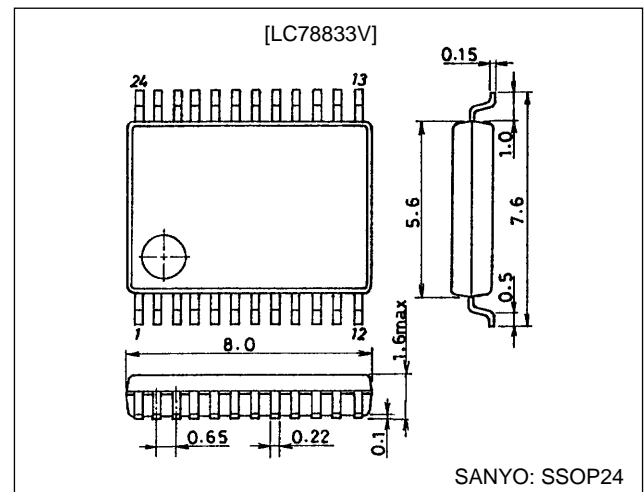

Specifications

Absolute Maximum Ratings at $T_a = 25^\circ\text{C}$, $V_{SS} = 0\text{ V}$

Parameter	Symbol	Conditions	Ratings	Unit
Maximum supply voltage	$V_{DD\text{ max}}$		-0.3 to +7.0	V
Maximum input voltage	$V_{IN\text{ max}}$		-0.3 to $V_{DD} + 0.3$	V
Maximum output voltage	$V_{OUT\text{ max}}$		-0.3 to $V_{DD} + 0.3$	V
Operating temperature	T_{opr}		-30 to +75	$^\circ\text{C}$
Storage temperature	T_{stg}		-40 to +125	$^\circ\text{C}$

SANYO Electric Co., Ltd. Semiconductor Business Headquarters

TOKYO OFFICE Tokyo Bldg., 1-10, 1 Chome, Ueno, Taito-ku, TOKYO, 110-8534 JAPAN

LC78833M, 78833V

Allowable Operating Ranges

Parameter	Symbol	Conditions	min	typ	max	Unit
Supply voltage	V_{DD}		3.0	5.0	5.5	V
Reference voltage (high)	Vref H		$V_{DD} - 0.3$		V_{DD}	V
Reference voltage (low)	Vref L		0		+0.3	V

Electrical Characteristics (1)

at $T_a = 25^\circ\text{C}$, $AV_{DD} = DV_{DD} = V_{ref H} = 5.0\text{ V}$, $AGND = DGND = V_{ref L} = 0\text{ V}$, unless otherwise specified

Parameter	Symbol	Conditions	min	typ	max	Unit
D/A converter resolution	RES			16		Bit
Total harmonic distortion	THD	At 1 kHz and 0 dB ^{*1}			0.08	%
Dynamic range	DR	At 1 kHz, -60 dB	92	94		dB
Crosstalk	CT	At 1 kHz and 0 dB			-85	dB
Signal-to-noise ratio	S/N	JIS-A	96	100		dB
Full-scale output voltage	VFS		2.6	2.8	3.0	Vp-p
Power dissipation	Pd	At fs = 44.1 kHz		60	90	mW
Output load resistance	RL	Pins 1 and 20 (1 and 24) ^{*2}	5			k Ω

Note: 1. Here, 0 dB means full scale.

2. Pin numbers in parentheses are for the LC78833V.

Electrical Characteristics (2)

at $T_a = 25^\circ\text{C}$, $AV_{DD} = DV_{DD} = V_{ref H} = 3.0\text{ V}$, $AGND = DGND = V_{ref L} = 0\text{ V}$, unless otherwise specified

Parameter	Symbol	Conditions	min	typ	max	Unit
D/A converter resolution	RES			16		Bit
Total harmonic distortion	THD	At 1 kHz and 0 dB ^{*1}			0.10	%
Dynamic range	DR	At 1 kHz, -60 dB	90	92		dB
Crosstalk	CT	At 1 kHz and 0 dB			-85	dB
Signal-to-noise ratio	S/N	JIS-A	94	98		dB
Full-scale output voltage	VFS		1.55	1.7	1.85	Vp-p
Power dissipation	Pd	At fs = 44.1 kHz		15	25	mW
Output load resistance	RL	Pins 1 and 20 (1 and 24) ^{*2}	30			k Ω

Note: 1. Here, 0 dB means full scale.

2. Pin numbers in parentheses are for the LC78833V.

Block Diagram

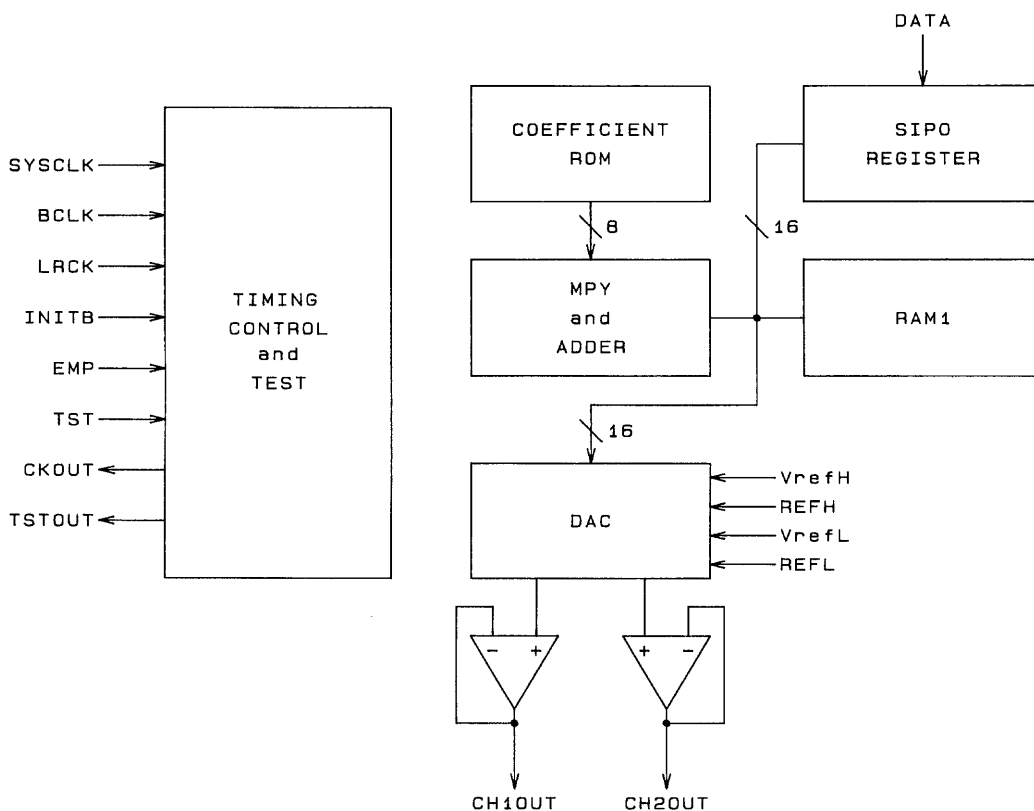

DC characteristics at Ta = -30 to 75°C, VDD = 3.0 to 5.5 V, VSS = 0 V

Parameter	Symbol	Conditions	min	typ	max	Unit
Input high-level voltage (1)	V _{IH1}	Pins 5, 6, 7, 12, 13, and 14 (pins 6, 7, 8, 14, 16, and 17)*	2.2			V
Input low-level voltage (1)	V _{IL1}	Pins 5, 6, 7, 12, 13, and 14 (pins 6, 7, 8, 14, 16, and 17)*			0.8	V
Input high-level voltage (2)	V _{IH2}	Pin 8 (pin 9)*	0.7 V _{DD}			V
Input low-level voltage (2)	V _{IL2}	Pin 8 (pin 9)*			0.3 V _{DD}	V
Output high-level voltage	V _{OH}	Pin 9 (pin 11)*: I _{OH} = -3 mA	2.4			V
Output low-level voltage	V _{OL}	Pin 9 (pin 11)*: I _{OL} = 3 mA			0.4	V
Input leakage current	I _L	Pins 5, 6, 7, 8, 12, 13, and 14 (pins 6, 7, 8, 9, 14, 16, and 17)*: V _I = V _{SS} , V _{DD}	-25		+25	µA

Note: * Pins in parentheses apply to the LC78833V.

AC Characteristics at Ta = -30 to 75°C, VDD = 3.0 to 5.5 V, VSS = 0 V

Parameter	Symbol	Conditions	min	typ	max	Unit
Clock pulse width	t _{cw}		25			ns
Clock pulse period	t _{cY}		50		1000	ns
BCLK pulse width	t _{bcw}		60			ns
BCLK pulse period	t _{bcY}		120			ns
Data setup time	t _{DS}		40			ns
Data hold time	t _{DH}		40			ns
LRCK setup time	t _{lRS}		40			ns
LRCK hold time	t _{lRH}		40			ns
BCLK rise time	t _{Br}				40	ns
BCLK fall time	t _{Bf}				40	ns
SYSCLK rise time	t _{Sr}				20	ns
SYSCLK fall time	t _{Sf}				20	ns

LC78833M, 78833V

Audio Input Waveforms

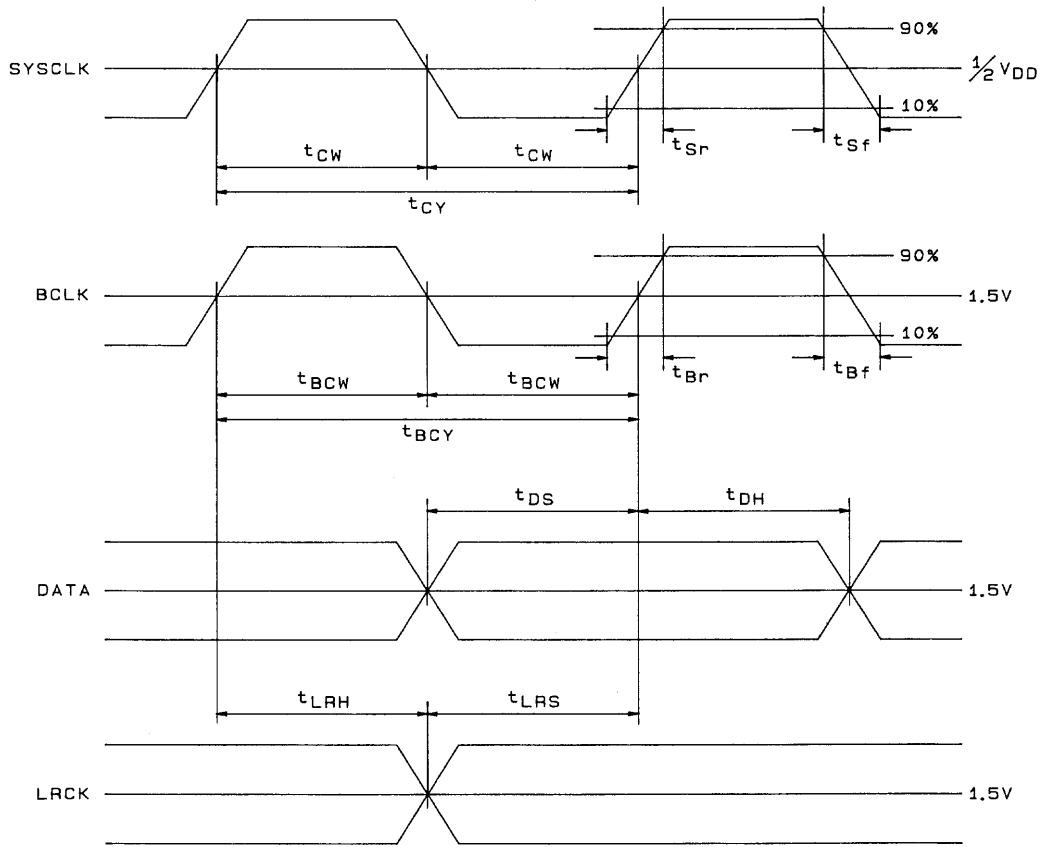

A04424

Pin Assignments

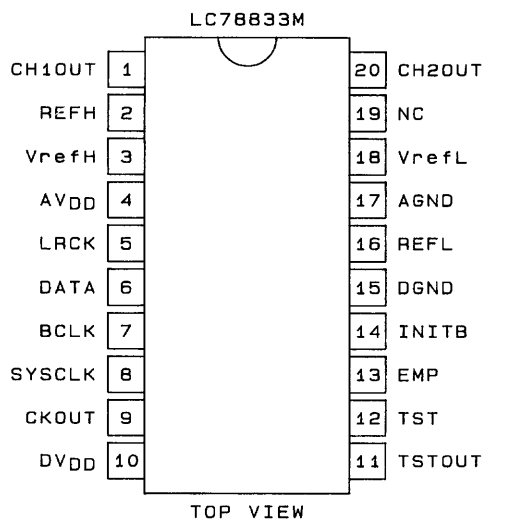

A04426

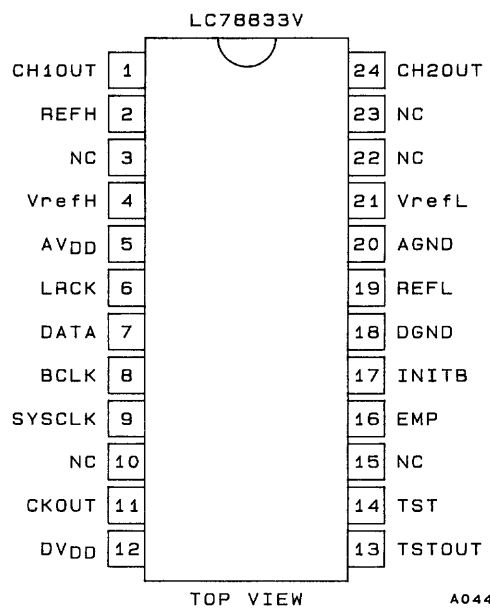

A04427

LC78833M, 78833V

Pin Functions

Pin No.		Pin	Description
LC78833M	LC78833V		
1	1	CH1OUT	Channel 1 analog output
2	2	REFH	High-level reference voltage Normally connected to AGND through a capacitor.
—	3	NC	No connection
3	4	Vref H	High-level reference voltage input
4	5	AV _{DD}	Analog system power supply
5	6	LRCK	LR clock input A high level specifies channel 1 and a low level channel 2.
6	7	DATA	Digital audio data input Accepts data in a two's complement MSB first format.
7	8	BCLK	Bit clock input
8	9	SYSCLK	System clock input (384fs)
—	10	NC	No connection
9	11	CKOUT	System clock output (384fs)
10	12	DV _{DD}	Digital system power supply
11	13	TSTOUT	Test output
12	14	TST	Test output This pin must be connected to DGND in normal operation.
—	15	NC	No connection
13	16	EMP	De-emphasis filter on/off control input A high level specifies on and a low level off. This function supports a sampling frequency f_s of 44.1 kHz.
14	17	INITB	Initialization input. A low level input to this pin initializes the IC.
15	18	DGND	Digital system ground
16	19	REFL	Low-level reference voltage Normally connected to AGND through a capacitor.
17	20	AGND	Analog system power supply
18	21	Vref L	Low-level reference voltage input
—	22	NC	No connection
19	23	NC	No connection
20	24	CH2OUT	Channel 2 analog output

LC78833M/V Operation

1. Digital Filters

The LC78833M and LC78833V perform the computations shown in the figure.

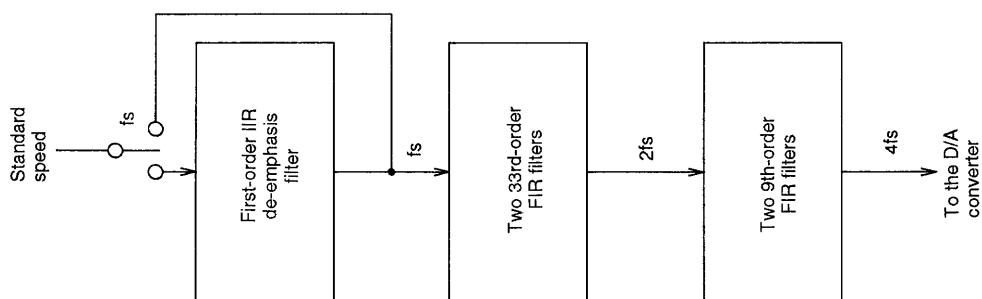

A04428

- Oversampling

The oversampling circuit in these ICs consists of two $2\times$ interpolation filters (implemented as FIR filters) connected vertically.

In particular, these ICs implement $4\times$ oversampling by the vertical connection of two FIR filter stages, a 33rd-order stage and a ninth-order stage. See page 9 for the filter characteristics.

- De-emphasis

A first-order IIR filter is used for de-emphasis. The filter coefficients are optimized for a sampling frequency of 44.1 kHz. See page 9 for the filter characteristics when de-emphasis is applied.

- De-emphasis on/off switching

De-emphasis is on when the EMP pin is high.

De-emphasis is off when the EMP pin is low.

2. Digital Audio Data Input

These ICs handle digital audio data in a 16-bit two's complement MSB first format. The 16-bit serial data is input to an internal register from the DATA pin on BCLK rising edges and read in on rising and falling edges of the LRCK signal.

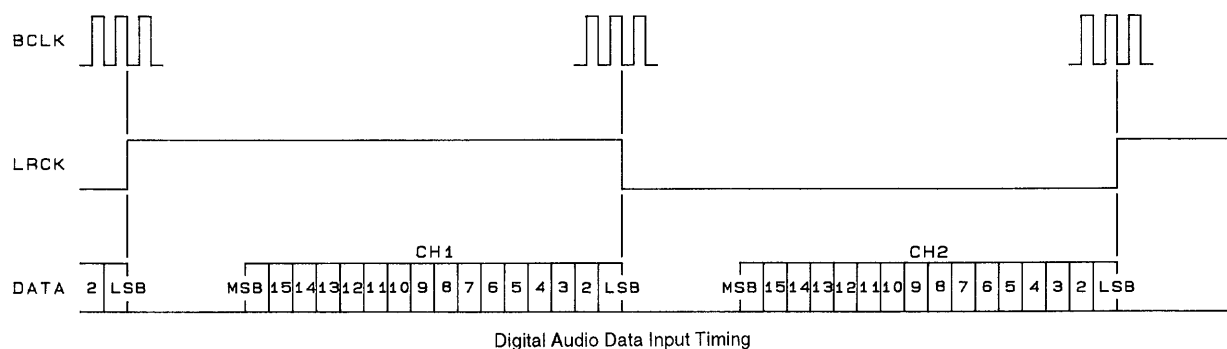

A04429

3. Initialization

These ICs must be initialized when power is first applied and when the system clock frequency is changed. Initialization is performed by applying a low level to the INITB pin. That low level must be held for at least one full cycle of the LRCK signal after the power supply voltage has stabilized and the SYSCLK, BCLK, and LRCK signals have been applied.

When INITB is low, all 16 bits of the digital filter outputs go to 0, and the D/A converter outputs (CH1OUT and CH2OUT) go to the analog 0 level, which is a potential equal to $(REFH + REFL)/2$.

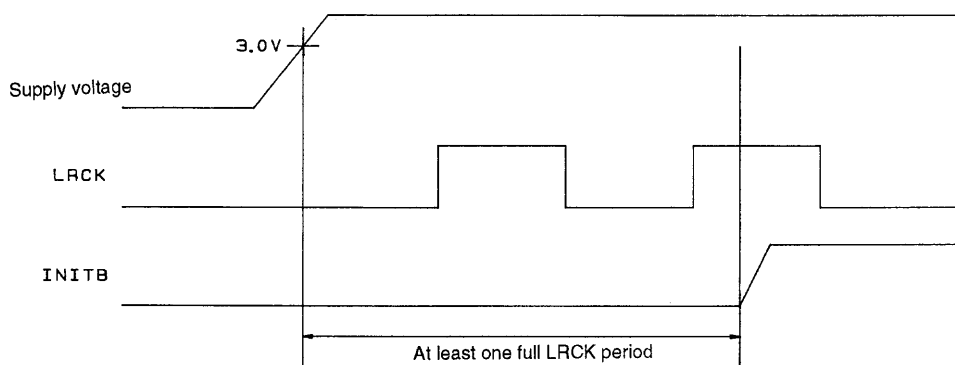

A04430

4. System Clock

These ICs support a 384fs system clock. Apply a 384fs clock to the SYSCLK pin.

- CKOUT pin

The SYSCLK and CKOUT pins are related as shown in the figure below.

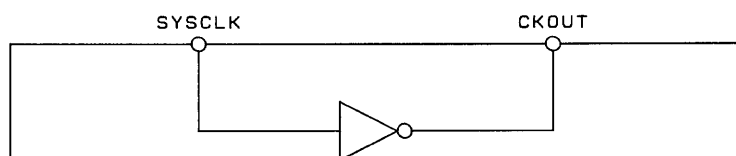

A04431

5. D/A Converter Block

Channel 1 and channel 2 each include an independent 16-bit D/A converter and an output operational amplifier. These D/A converters use the dynamic level-shifting conversion scheme shown in the figure below. This scheme combines three conversion techniques, resistor string D/A conversion, PWM (pulse width modulation) D/A conversion, and level-shifting D/A conversion.

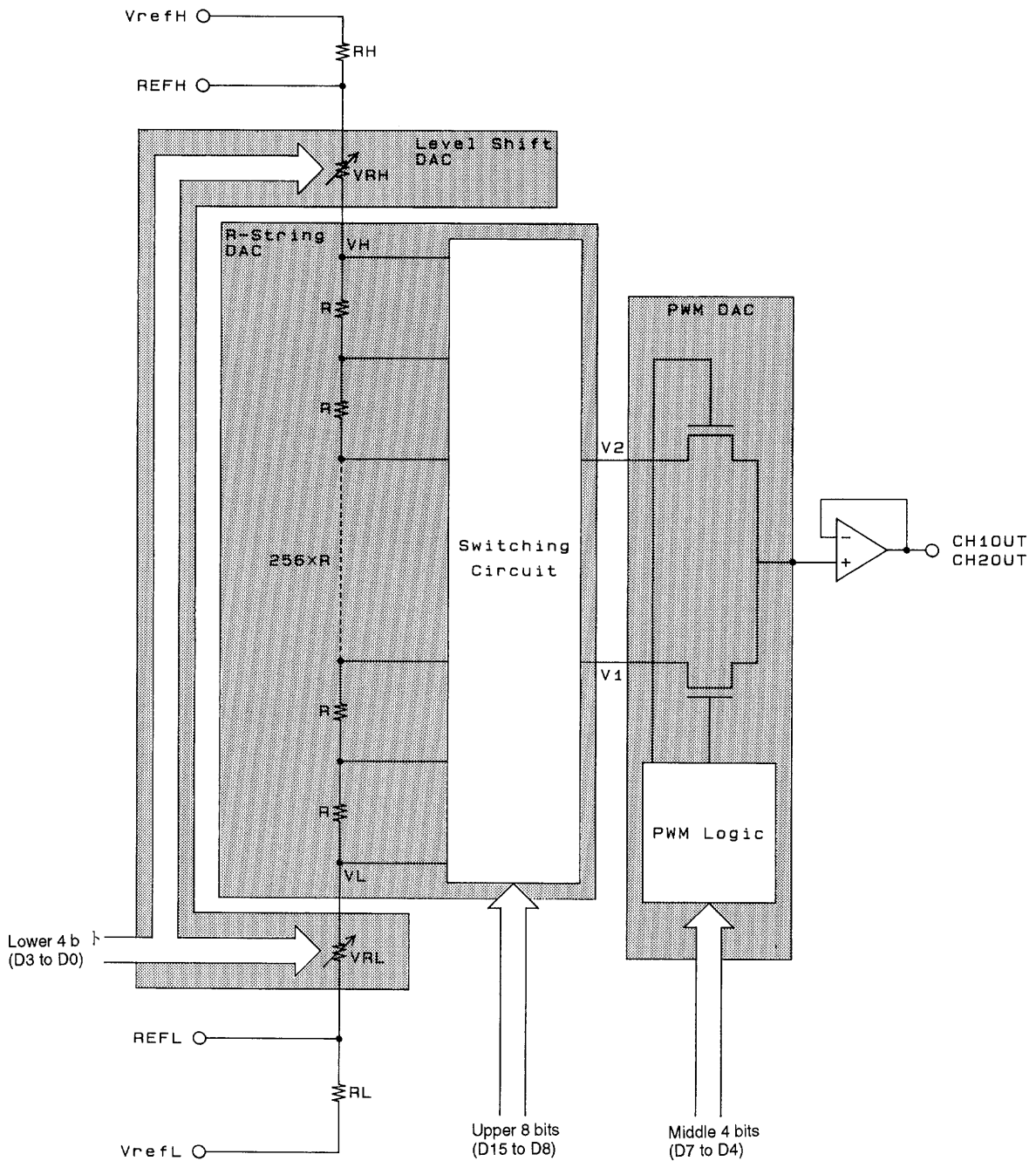

A04432

- Resistor string D/A converter

This 8-bit D/A converter uses a total of 256 (= 2⁸) unit-resistance (R) resistors connected in series to voltage divide the potential applied to the ends of that resistor string into 256 equal intervals. Of these resistor-divided potentials, two adjacent potentials, V1 and V2, are selected by a switching circuit according to the value of the upper 8 bits (D15 to D8) of the data. These two potentials are output to the PWM D/A converter. Note that these potentials are related as follows:

$$V2 - V1 = (VH - VL)/256$$

- PWM D/A converter

This 4-bit D/A converter divides (by 16) the interval between the two potentials, V1 and V2, output by the resistor-string D/A converter. This circuit outputs one or the other of the V1 and V2 potentials from the CH1OUT (or CH2OUT) pin according to the value of the middle 4 bits (D7 to D4) of the data.

- Level shifting D/A converter

This 4-bit D/A converter is implemented by connecting the variable resistors VRH and VRL in series at the ends of the resistor-string D/A converter. The values of the VRH and VRL variable resistors are modified according to the value of the low-order 4 bits of the data as follows:

- The value of VRH + VRL is held fixed regardless of the value of the data.
- The values of VRH and VRL are changed in R/256 unit steps (where R is the value of the resistor-string D/A converter unit resistors) over the range zero to 15·R/256.

This causes the resistor-string D/A converter V1 and V2 outputs to change in ΔV/256 steps (where ΔV = (VH - VL)/256) over the range 0 to 15 × ΔV/256 according to the value of the lower 4 bits of the data.

- The Vref H/L and REFH/L pins

The Vref H/L pins provide the reference voltage to the resistor string, and are normally connected to AV_{DD} and AGND, respectively. REFH and REFL are each connected to AGND through a capacitor of about 10 μF.

The maximum output amplitude is acquired when Vref H is 5.0 V and Vref L is 0 V. The internal resistors RH and RL cause the output range to be between 0.7 V (minimum) and 3.5 V (maximum) (2.8 V_{p-p}) for 0 dB.

Filter Characteristics (as calculated)

4× oversampling

Ripple: Less than ±0.1 dB

Attenuation: -35 dB or lower

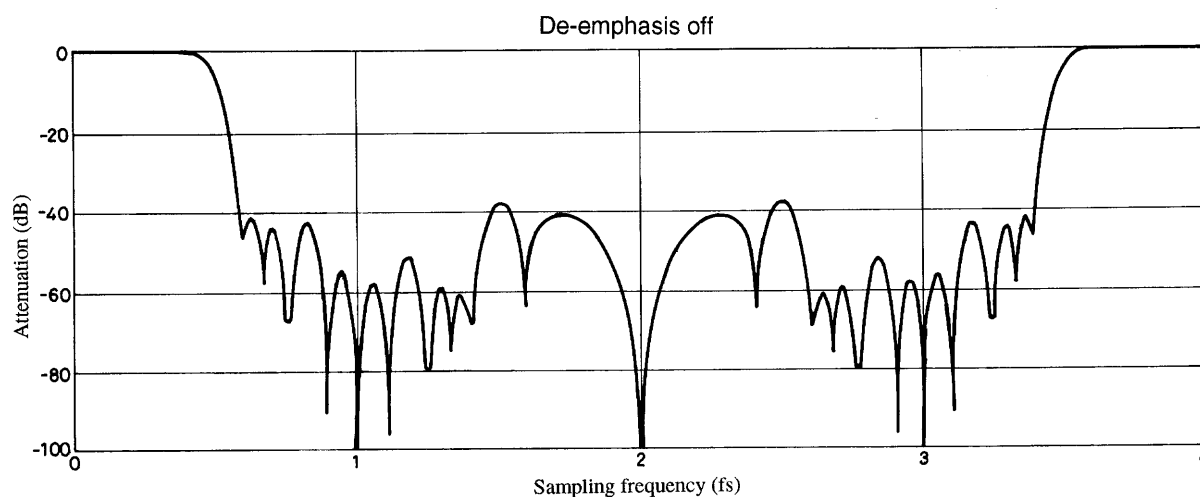

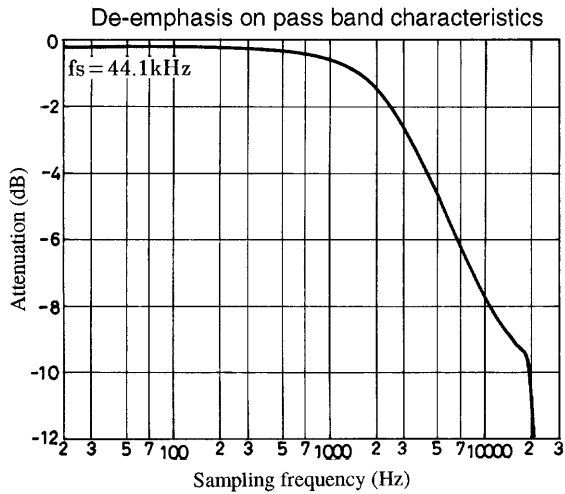

Application Circuit Example

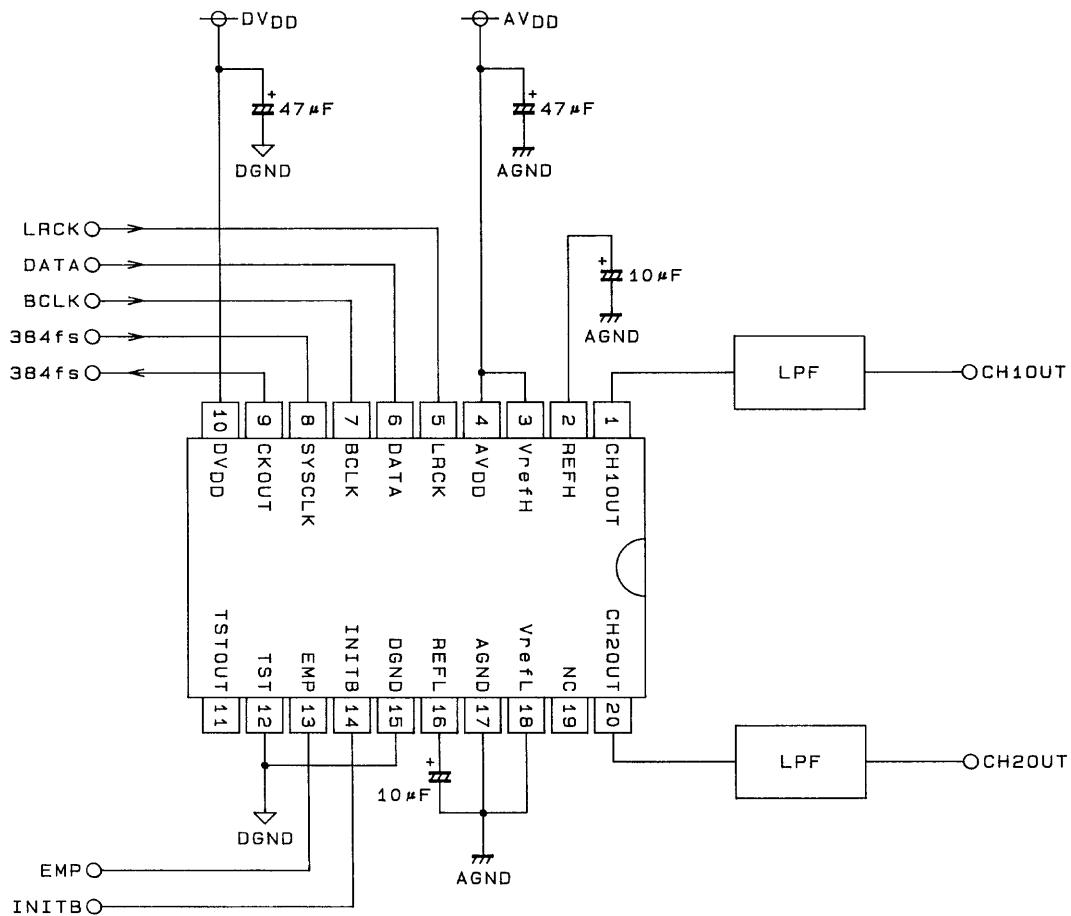

A04433

$DV_{DD} = AV_{DD} = 3.0 \text{ to } 5.5 \text{ V}$
 LPF: Low-pass filter ($F_c = 20 \text{ kHz}$)

- Note
1. V_{DD} and V_{refH} must be provided from a low-impedance, high-stability power supply, for example, a commercial three-terminal regulator or equivalent.
 2. Since it is possible for the IC to latch up if there is a discrepancy between the pin 4 (AV_{DD}) and pin 10 (DV_{DD}) power supply power-on timing, application circuits should be designed so that there is no time difference between the application of these voltages.
 3. Bypass capacitors of at least $47 \mu\text{F}$ must be inserted between AV_{DD} and $AGND$ and between DV_{DD} and $DGND$. These capacitor must be placed as close as possible to the IC.
 4. Bypass capacitors of at least $10 \mu\text{F}$ must be inserted between $REFH$ and $AGND$ and between $REFL$ and $AGND$ for reference voltage stability.

Power On Timing

1. The analog power supply (AV_{DD}) and the digital power supply (DV_{DD}) should be applied (or removed) at the same time.
2. If a time difference between application of the analog and digital power supplies cannot be avoided, the timing must meet the following conditions:
 - The power supply power up (and power down) time differences must be under 3 ms. (See Figure 1.)
 - If the time difference exceeds 3 ms, the rise (fall) time of the power supply that rises (falls) first must be at least 5 ms, and the time difference must be under 50 ms. (See Figure 2.)

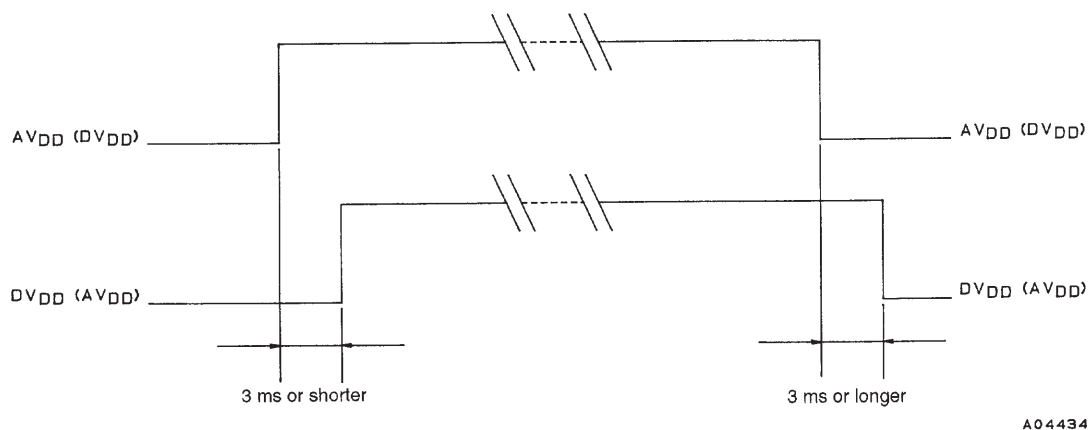

Figure 1

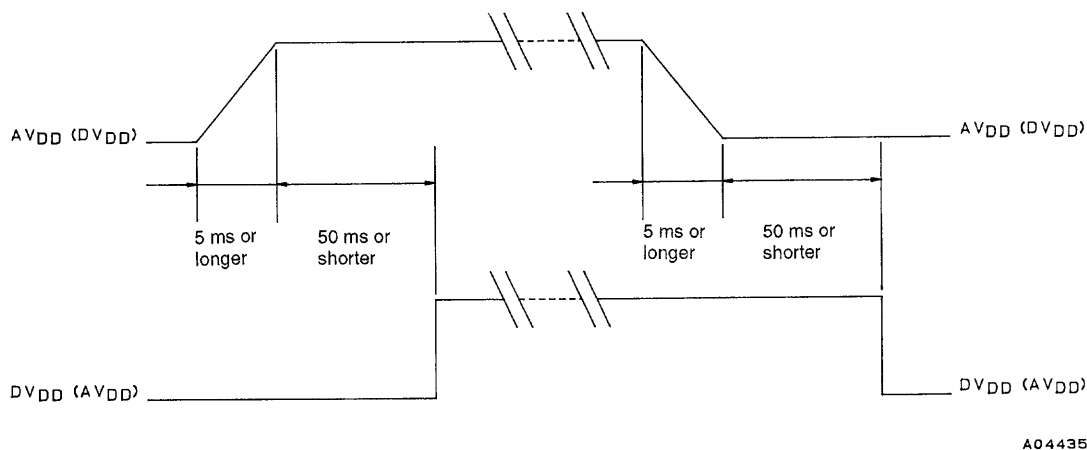

Figure 2

- No products described or contained herein are intended for use in surgical implants, life-support systems, aerospace equipment, nuclear power control systems, vehicles, disaster/crime-prevention equipment and the like, the failure of which may directly or indirectly cause injury, death or property loss.
- Anyone purchasing any products described or contained herein for an above-mentioned use shall:
 - ① Accept full responsibility and indemnify and defend SANYO ELECTRIC CO., LTD., its affiliates, subsidiaries and distributors and all their officers and employees, jointly and severally, against any and all claims and litigation and all damages, cost and expenses associated with such use:
 - ② Not impose any responsibility for any fault or negligence which may be cited in any such claim or litigation on SANYO ELECTRIC CO., LTD., its affiliates, subsidiaries and distributors or any of their officers and employees jointly or severally.
- Information (including circuit diagrams and circuit parameters) herein is for example only; it is not guaranteed for volume production. SANYO believes information herein is accurate and reliable, but no guarantees are made or implied regarding its use or any infringements of intellectual property rights or other rights of third parties.

This catalog provides information as of February, 1997. Specifications and information herein are subject to change without notice.