



FC154

NPN/PNP Epitaxial Planar Silicon Transistor High-Speed Switching, High-Frequency Amp Applications

Features

- Composite type with NPN transistor and a PNP transistor contained in the conventional CP package, improving the mounting efficiency greatly.
- The FC154 is formed with two chips, being equivalent to the 2SC4270 and the other the 2SA1699, placed in one package.

Electrical Connection

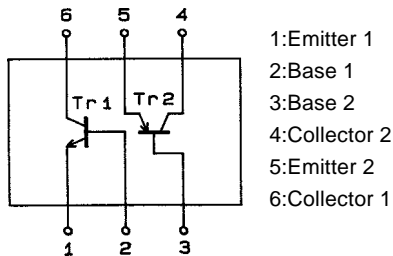

Package Dimensions

unit:mm

2104A

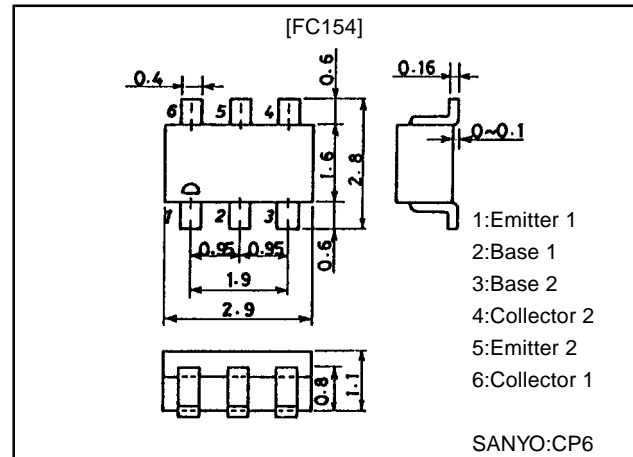

Specifications

Absolute Maximum Ratings at $T_a = 25^\circ\text{C}$

Parameter	Symbol	Conditions	Ratings	Unit
[TR1 (NPN Tr)]				
Collector-to-Base Voltage	V_{CB0}		25	V
Collector-to-Emitter Voltage	V_{CEO}		15	V
Emitter-to-Base Voltage	V_{EBO}		3	V
Collector Current	I_C		50	mA
Collector Dissipation	P_C		200	mW
[TR2 (PNPTr)]				
Collector-to-Base Voltage	V_{CB0}		-20	V
Collector-to-Emitter Voltage	V_{CEO}		-15	V
Emitter-to-Base Voltage	V_{EBO}		-3	V
Collector Current	I_C		-50	mA
Collector Dissipation	P_C		200	mW
[Common Ratings]				
Total Dissipation	P_T		300	mW
Junction Temperature	T_J		150	$^\circ\text{C}$
Storage Temperature	T_{stg}		-55 to +150	$^\circ\text{C}$

Marking:154

Continued on next page.

FC154

Continued from Preceding page.

Electrical Characteristics at $T_a = 25^\circ\text{C}$

Parameter	Symbol	Conditions	Ratings			Unit
			min	typ	max	
[TR1 (NPN Tr)]						
Collector Cutoff Current	I_{CBO}	$V_{CB}=20\text{V}, I_E=0$			0.1	μA
Emitter Cutoff Current	I_{EBO}	$V_{EB}=2\text{V}, I_C=0$			10	μA
DC Current Gain	h_{FE}	$V_{CE}=10\text{V}, I_C=5\text{mA}$	60		200	
Gain-Bandwidth Product	f_T	$V_{CE}=10\text{V}, I_C=10\text{mA}$	1.5	3.0		GHz
Output Capacitance	C_{ob}	$V_{CB}=10\text{V}, f=1\text{MHz}$		0.7	1.0	pF
Power Gain	PG	$V_{CE}=10\text{V}, I_C=10\text{mA}, f=0.9\text{GHz}$		12		dB
Noise Figure	NF	$V_{CE}=10\text{V}, I_C=3\text{mA}, f=0.9\text{GHz}$		3.0		dB
[TR2 (PNPTr)]						
Collector Cutoff Current	I_{CBO}	$V_{CB}=-15\text{V}, I_E=0$			-0.1	μA
Emitter Cutoff Current	I_{EBO}	$V_{EB}=-2\text{V}, I_C=0$			-0.1	μA
DC Current Gain	h_{FE}	$V_{CE}=-10\text{V}, I_C=-5\text{mA}$	20		100	
Gain-Bandwidth Product	f_T	$V_{CE}=-10\text{V}, I_C=-5\text{mA}$	1.5	3.0		GHz
Output Capacitance	C_{ob}	$V_{CB}=-10\text{V}, f=1\text{MHz}$		1.0	1.5	pF
Forward Transfer Gain	$ S_{21e} ^2$	$V_{CE}=-10\text{V}, I_C=-5\text{mA}, f=0.9\text{GHz}$	5			dB
Noise Figure	NF	$V_{CE}=-10\text{V}, I_C=-3\text{mA}, f=0.9\text{GHz}$		2.0		dB

PG, NF Test Circuit

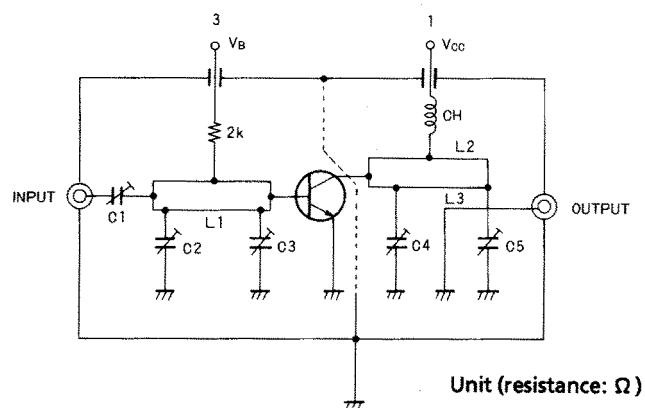

900MHz	
C1	$\sim 5\text{pF}$
C2	$\sim 10\text{pF}$
C3	$\sim 10\text{pF}$
C4	$\sim 10\text{pF}$
C5	$\sim 10\text{pF}$
L1	$W \div 1.5\text{mm}, 1 \div 25\text{mm}$ strip line
L2	$W \div 4\text{mm}, 1 \div 25\text{mm}$ strip line
L3	$0.5\phi, 1 \div 40\text{mm}$
CH	2t + bead core

FC154

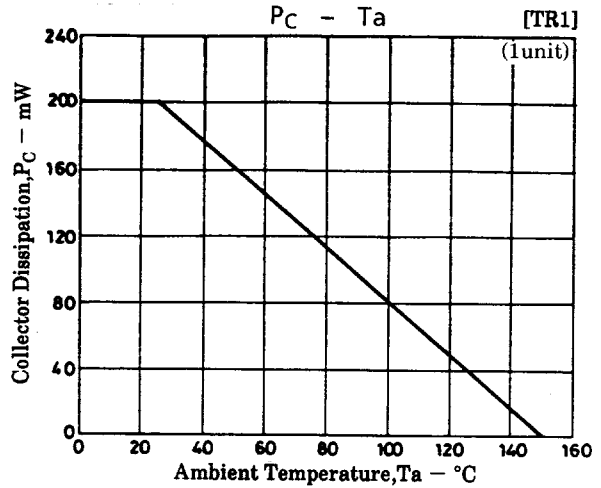
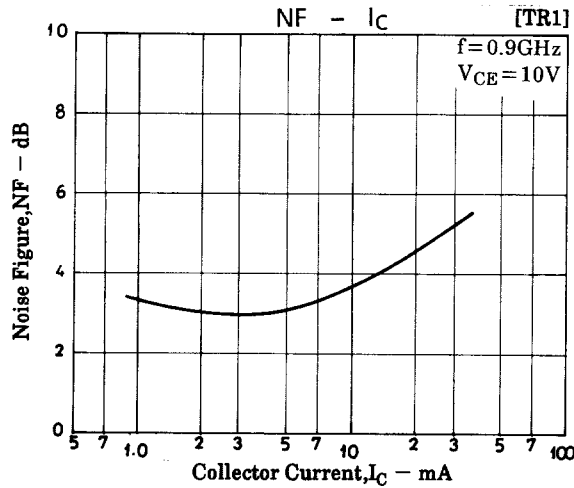
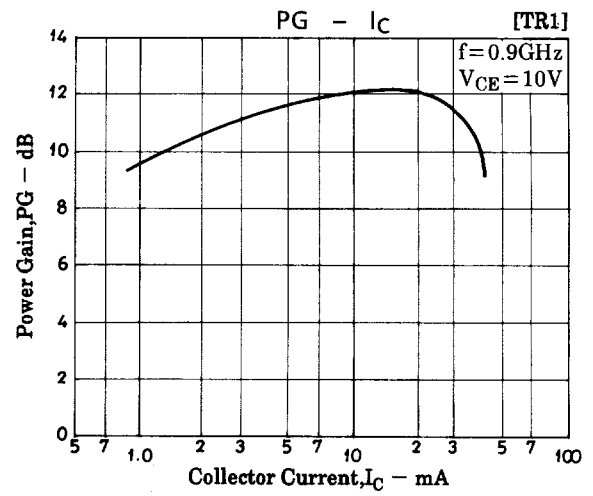
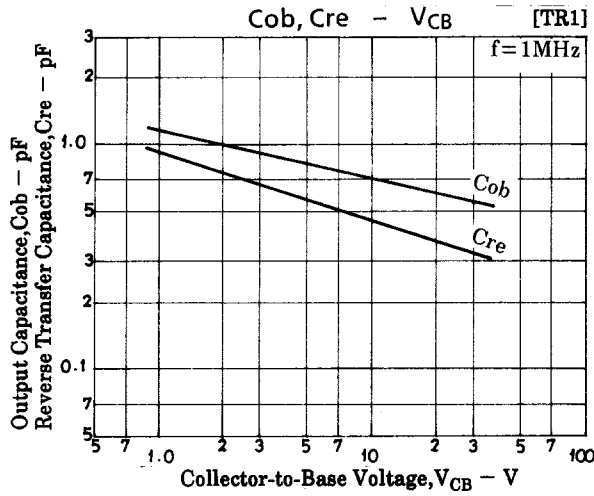
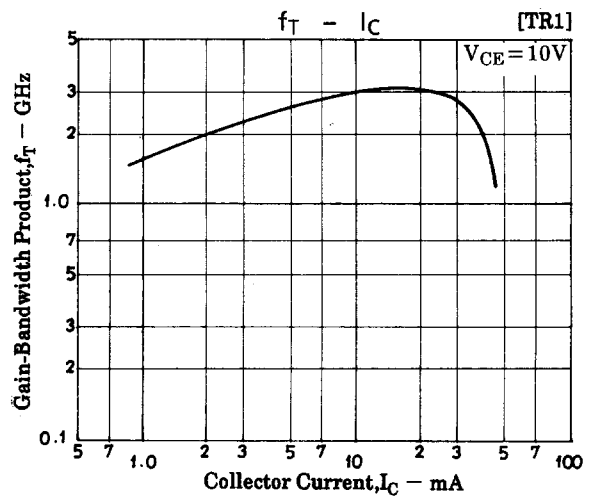
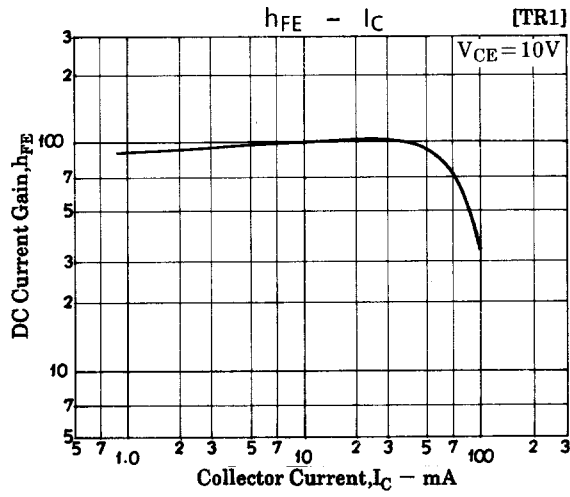

FC154

S parameter [TR1]

S11e: $V_{CE} = 10V$

$f = 100MHz, 200$ to $1200MHz$ (200MHz step)

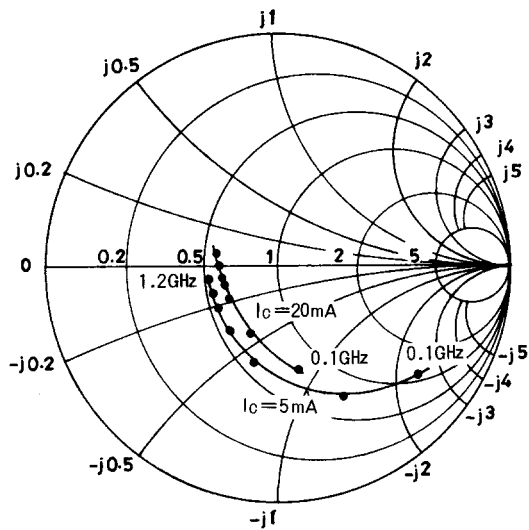

S12e: $V_{CE} = 10V$

$f = 100MHz, 200$ to $1200MHz$ (200MHz step)

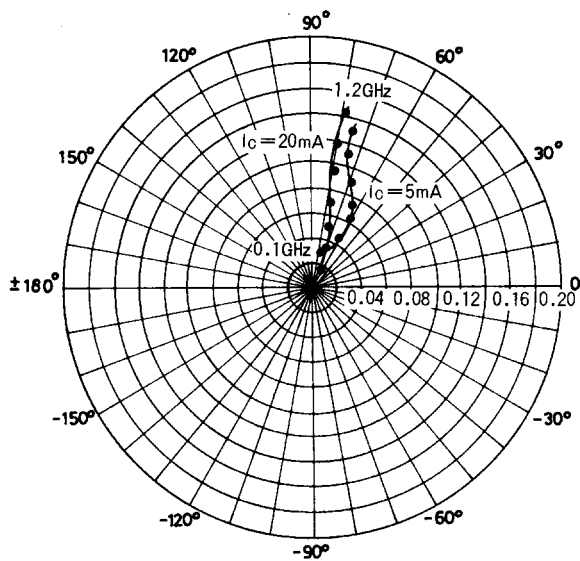

S21e: $V_{CE} = 10V$

$f = 100MHz, 200$ to $1200MHz$ (200MHz step)

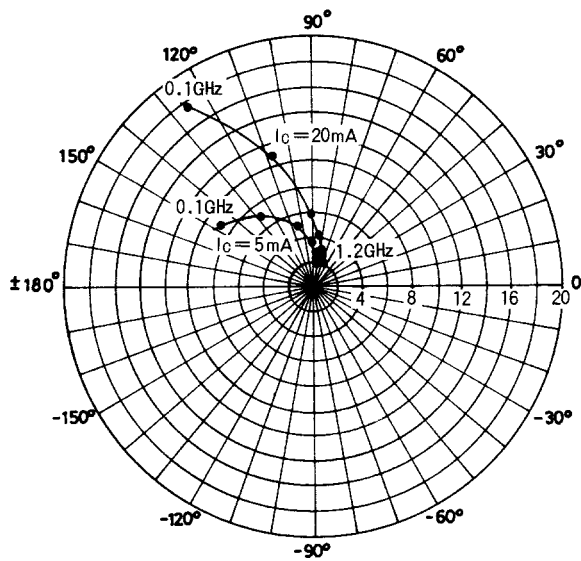

S22e: $V_{CE} = 10V$

$f = 100MHz, 200$ to $1200MHz$ (200MHz step)

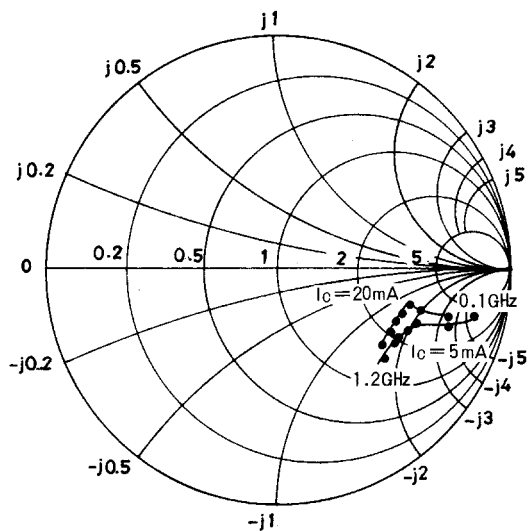

FC154

S parameter (Common emitter) [TR1]

$V_{CE} = 10V, I_C = 5mA, Z_0 = 50\Omega$

Freq (MHz)	$ S_{11} $	$\angle S_{11}$	$ S_{21} $	$\angle S_{21}$	$ S_{12} $	$\angle S_{12}$	$ S_{22} $	$\angle S_{22}$
100	0.771	-35.1	8.763	147.2	0.027	69.3	0.890	-14.2
200	0.613	-64.7	7.004	127.6	0.043	59.8	0.780	-19.7
400	0.429	-110.7	4.882	103.1	0.061	58.1	0.660	-22.8
600	0.361	-133.5	3.471	90.5	0.075	63.1	0.625	-25.1
800	0.355	-148.4	2.693	81.6	0.091	68.1	0.612	-28.6
900	0.331	-153.7	2.450	78.9	0.100	70.5	0.609	-29.9
1000	0.328	-158.9	2.236	75.5	0.110	72.5	0.607	-31.6
1200	0.326	-167.9	1.932	69.9	0.130	74.7	0.608	-35.7

$V_{CE} = 10V, I_C = 20mA, Z_0 = 50\Omega$

Freq (MHz)	$ S_{11} $	$\angle S_{11}$	$ S_{21} $	$\angle S_{21}$	$ S_{12} $	$\angle S_{12}$	$ S_{22} $	$\angle S_{22}$
100	0.447	-78.1	17.728	125.0	0.020	66.0	0.752	-18.5
200	0.338	-113.2	10.936	107.5	0.031	66.5	0.639	-18.5
400	0.290	-146.6	5.773	91.4	0.052	72.1	0.580	-18.5
600	0.281	-159.3	3.956	83.0	0.074	75.7	0.571	-21.1
800	0.285	-168.8	2.982	76.2	0.095	77.6	0.566	-25.2
900	0.289	-171.3	2.703	74.0	0.106	78.6	0.563	-26.7
1000	0.291	-174.4	2.454	71.3	0.118	79.4	0.565	-28.6
1200	0.297	-178.1	2.116	66.5	0.140	79.0	0.569	-33.1

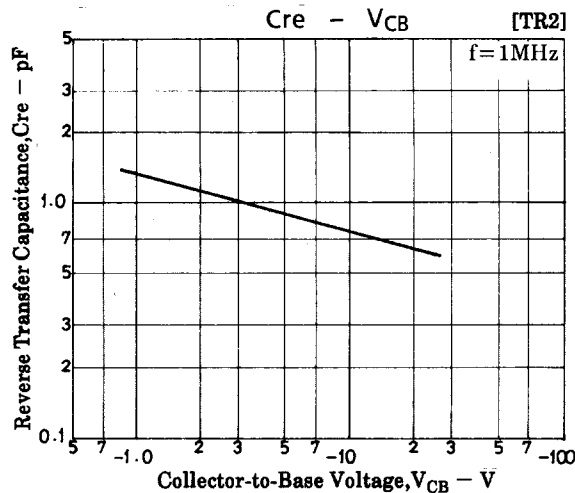
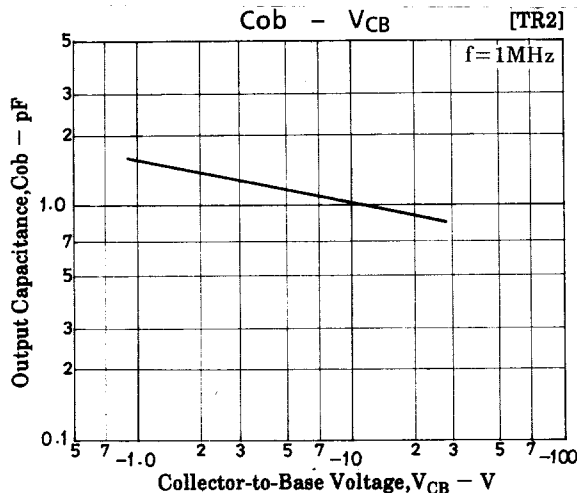
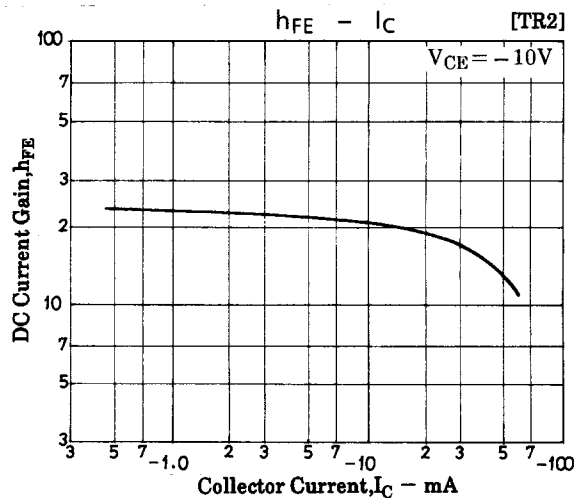
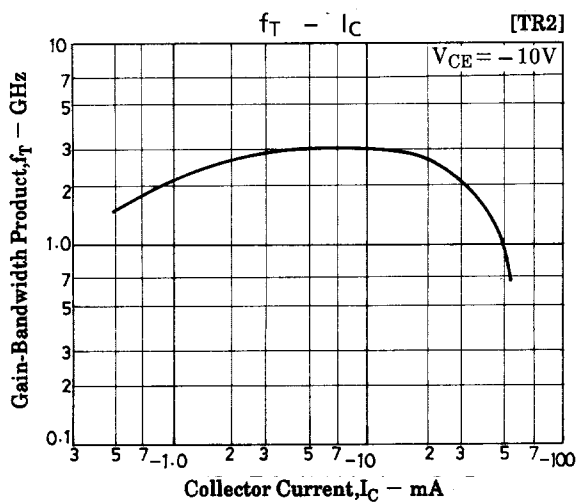

FC154

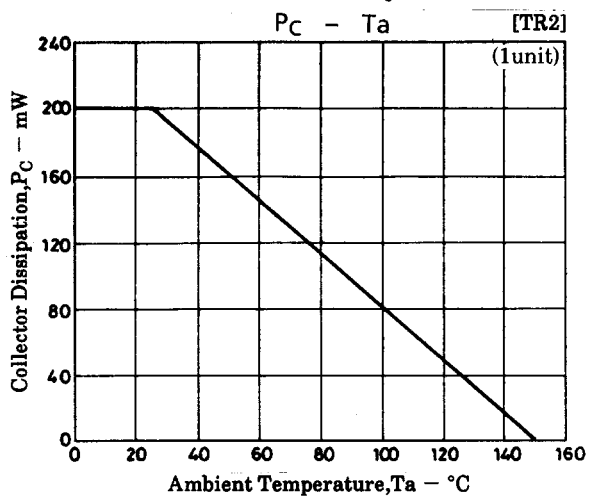
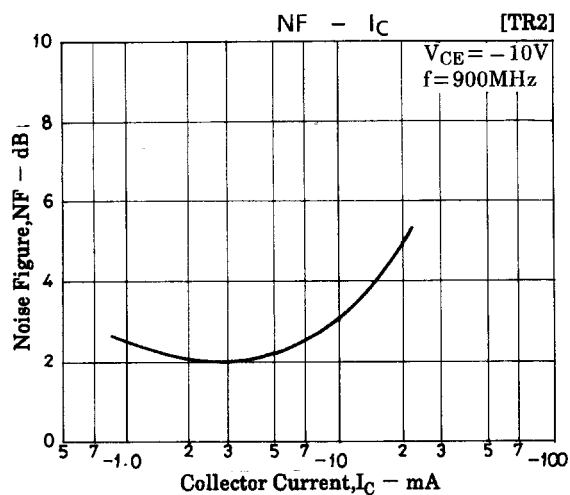
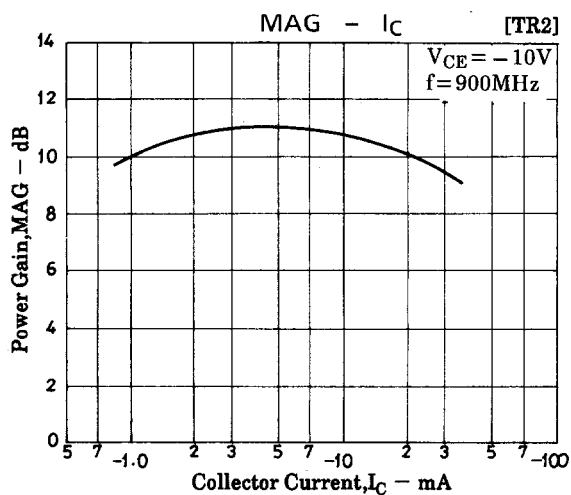

S parameter [TR2]

S11e: $V_{CE} = -10V$
 $f = 100MHz, 200$ to $1200MHz$ (200MHz step)

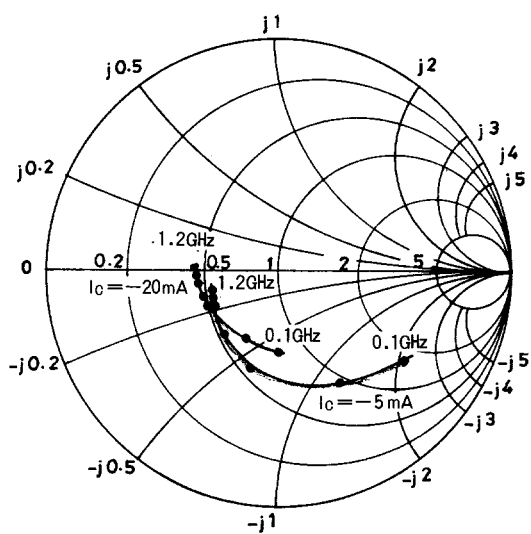

S12e: $V_{CE} = -10V$
 $f = 100MHz, 200$ to $1200MHz$ (200MHz step)

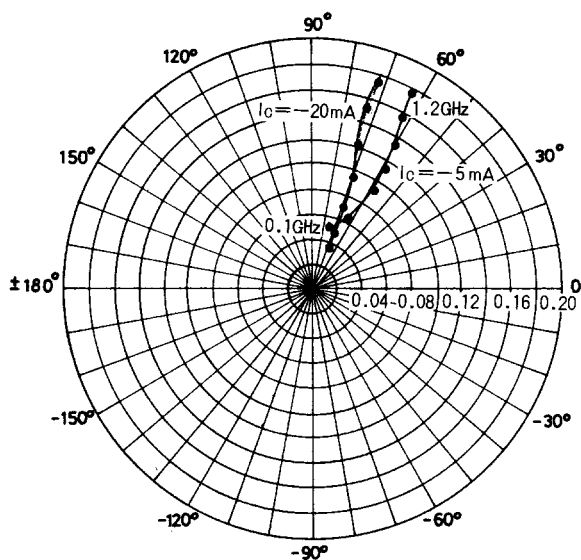

FC154

**S21e : $V_{CE} = -10V$
f = 100MHz, 200 to 1200MHz (200MHz step)**

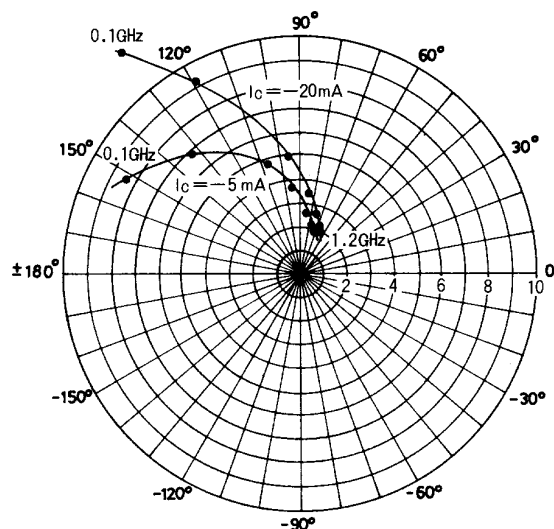

**S22e : $V_{CE} = -10V$
f = 100MHz, 200 to 1200MHz (200MHz step)**

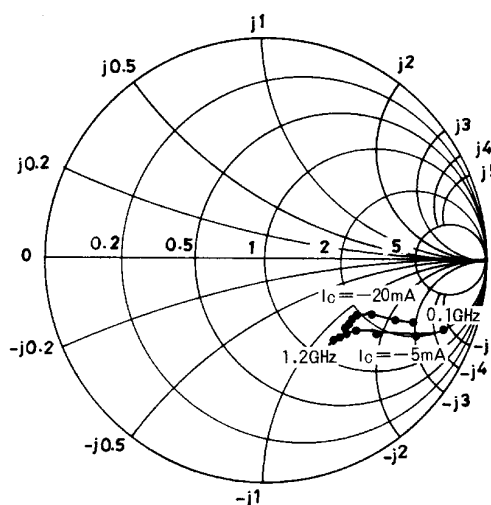

S parameter (Common emitter) [TR2]

$V_{CE} = -10V, I_C = -5mA, Z_0 = 50\Omega$

Freq (MHz)	S ₁₁	∠S ₁₁	S ₂₁	∠S ₂₁	S ₁₂	∠S ₁₂	S ₂₂	∠S ₂₂
100	0.707	-33.1	8.215	151.1	0.043	68.6	0.856	-19.8
200	0.589	-60.3	6.763	132.2	0.059	62.0	0.761	-25.4
400	0.435	-104.7	4.810	106.5	0.089	56.4	0.584	-34.2
600	0.373	-128.1	3.503	93.2	0.110	57.3	0.508	-36.6
800	0.349	-144.4	2.728	83.4	0.130	59.5	0.474	-39.0
900	0.346	-150.1	2.492	80.0	0.142	60.9	0.464	-40.3
1000	0.344	-155.4	2.266	76.8	0.154	61.4	0.459	-41.7
1200	0.340	-163.6	1.971	70.6	0.176	62.1	0.452	-45.2

$V_{CE} = -10V, I_C = -20mA, Z_0 = 50\Omega$

Freq (MHz)	S ₁₁	∠S ₁₁	S ₂₁	∠S ₂₁	S ₁₂	∠S ₁₂	S ₂₂	∠S ₂₂
100	0.348	-92.8	12.039	129.4	0.031	67.3	0.727	-22.9
200	0.330	-116.7	9.073	118.2	0.041	66.0	0.634	-24.8
400	0.350	-151.2	4.962	95.1	0.068	67.7	0.510	-26.5
600	0.353	-164.5	3.408	84.4	0.093	69.9	0.481	-28.1
800	0.360	-172.9	2.591	76.4	0.118	71.6	0.470	-31.1
900	0.366	-176.2	2.346	73.3	0.131	72.0	0.467	-32.9
1000	0.371	-178.4	2.142	70.8	0.146	71.8	0.467	-34.8
1200	0.379	176.2	1.851	65.2	0.171	71.1	0.466	-39.1

■ No products described or contained herein are intended for use in surgical implants, life-support systems, aerospace equipment, nuclear power control systems, vehicles, disaster/crime-prevention equipment and the like, the failure of which may directly or indirectly cause injury, death or property loss.

■ Anyone purchasing any products described or contained herein for an above-mentioned use shall:

- ① Accept full responsibility and indemnify and defend SANYO ELECTRIC CO., LTD., its affiliates, subsidiaries and distributors and all their officers and employees, jointly and severally, against any and all claims and litigation and all damages, cost and expenses associated with such use:
- ② Not impose any responsibility for any fault or negligence which may be cited in any such claim or litigation on SANYO ELECTRIC CO., LTD., its affiliates, subsidiaries and distributors or any of their officers and employees jointly or severally.

■ Information (including circuit diagrams and circuit parameters) herein is for example only; it is not guaranteed for volume production. SANYO believes information herein is accurate and reliable, but no guarantees are made or implied regarding its use or any infringements of intellectual property rights or other rights of third parties.

This catalog provides information as of May, 1998. Specifications and information herein are subject to change without notice.