

### HIGH-PERFORMANCE PRODUCTS

#### Description

The SK10/100E016 is a high-speed synchronous, presettable, cascadable 8-bit binary counter.

The counter features internal feedback of TC\*, gated by the TCLD (terminal count load) pin. When TCLD is LOW (or left open, in which case it is pulled LOW by the internal pull-downs), the TC\* feedback is disabled, and counting proceeds continuously, with TC\* going LOW to indicate an all-one state. When TCLD is HIGH, the TC\* feedback causes the counter to automatically reload upon TC\* = LOW, thus functioning as a programmable counter. The Qn outputs do not need to be terminated for the count function to operate properly. To minimize noise and power, unused Q outputs should be left unterminated.

#### Features

- 700 MHz Min Count Frequency
- 1000 ps CLK to Q, TC\*
- Internal TC\* Feedback (Gated)
- 8-Bit
- Fully Synchronous Counting and TC\* Generation
- Asynchronous Master Reset
- Internal 75 kΩ Input Pulldown Resistors
- Extended 100E V<sub>EE</sub> Range of -4.2V to -5.46V
- Fully Compatible with MC10/100E016
- Available in 28-Pin PLCC Package
- ESD Protection of >4000V

### Functional Block Diagram

8 Bit Binary Counter - Logic Counter

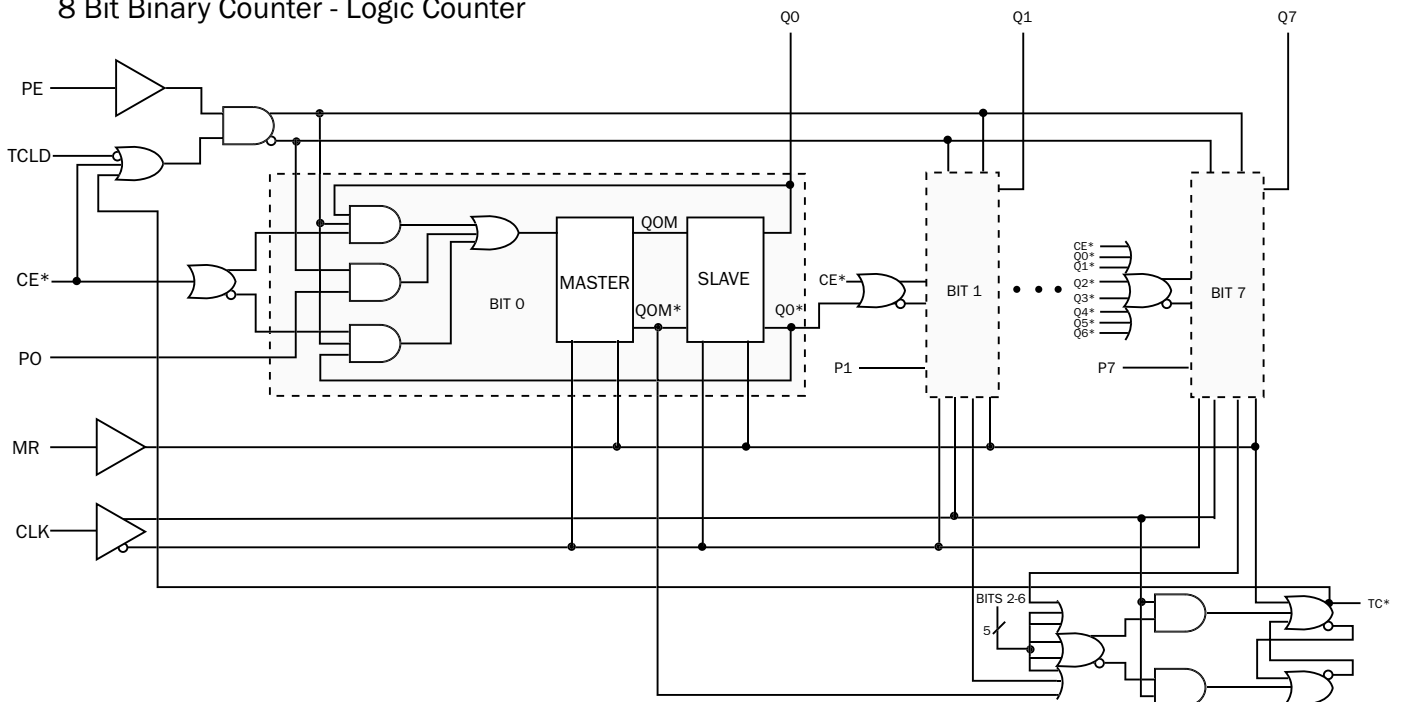

Note that this diagram is provided for understanding of logic operation only. It should not be used for propagation delays as many gate functions are achieved internally without incurring a full gate delay.

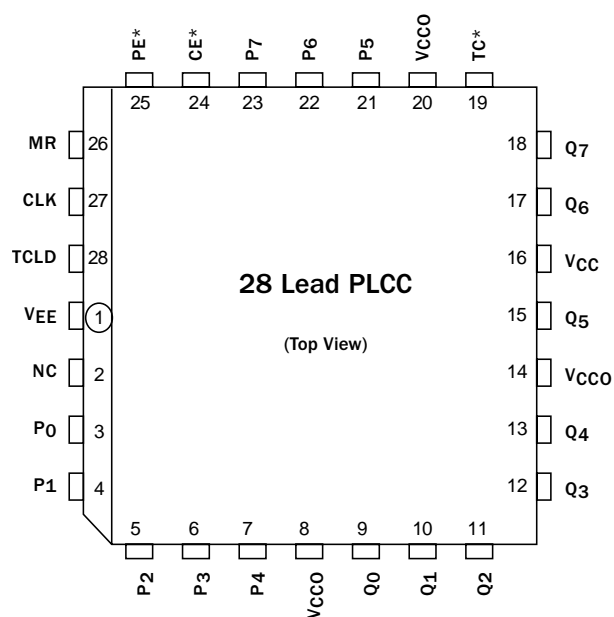
**Pinout**

**Function Table**

CE*	PE*	TCLD	MR	CLK	Function
X	L	X	L	Z	Load Parallel (P <sub>n</sub> to Q <sub>n</sub> )
L	H	L	L	Z	Continuous Count
L	H	H	L	Z	Count; Load Parallel on TC* = LOW
H	H	X	L	Z	Hold
X	X	X	L	ZZ	Masters Respond, Slaves Hold
X	X	X	H	X	Reset (Q <sub>n</sub> : = LOW, TC*: = HIGH)

**Pin Names**

Pin	Function
P0 - P7	Parallel Data (Preset) Inputs
Q0 - Q7	Data Outputs
CE*	Count Enable Control Input
PE*	Parallel Load Enable Control Input
MR	Master Reset
CLK	Clock
TC*	Terminal Count Output
TCLD	TC-Load Control Input

**Function Table**

Function	PE*	CE*	MR	TCLD	CLK	P7-P4	P3	P2	P1	P0	Q7-Q4	Q3	Q2	Q1	Q0	TC
Load	L	X	L	X	Z	H	H	H	L	L	H	H	H	L	L	H
Count	H	L	L	L	Z	X	X	X	X	X	H	H	H	L	H	H
	H	L	L	L	Z	X	X	X	X	X	H	H	H	H	L	H
	H	L	L	L	Z	X	X	X	X	X	H	H	H	H	H	L
	H	L	L	L	Z	H	H	H	L	L	H	H	H	L	L	H
Load	L	X	L	X	Z	H	H	H	L	L	H	H	H	L	L	H
Hold	H	H	L	X	Z	X	X	X	X	X	H	H	H	L	L	H
	H	H	L	X	Z	X	X	X	X	X	H	H	H	L	L	H
Load On	H	L	L	H	Z	H	L	H	H	L	H	H	H	L	H	H
Terminal Count	H	L	L	H	Z	H	L	H	H	L	H	H	H	H	L	H
	H	L	L	H	Z	H	L	H	H	L	H	H	H	H	H	L
	H	L	L	H	Z	H	L	H	H	L	H	L	H	H	L	H
	H	L	L	H	Z	H	L	H	H	L	H	L	H	H	H	H
Reset	X	X	H	X	X	X	X	X	X	X	L	L	L	L	L	G

**Cascading Multiple E016 Devices**

For applications which call for larger than 8-bit counters, multiple E016s can be tied together to achieve very wide bit width counters. The active low terminal count (TC\*) output and count enable input (CE\*) greatly facilitate the cascading of E016 devices. Two E016s can be cascaded without the need for external gating; however, for counters wider than 16 bits, external OR gates are necessary for cascade implementations.

Figure 3 below illustrates the cascading of 4 E016s to build a 32-bit high frequency counter. Note that the E101 gates are used to OR the terminal count outputs of the lower order E016s to control the counting operation of the higher order bits. When the terminal count of the preceding device (or devices) goes low (the counter reaches an all 1s state), the more significant E016 is set in its count mode and will count one binary digit upon the next positive clock transition. In addition, the preceding devices will also count one bit, sending their terminal count outputs back to a high state, disabling the count operation of the more significant counters, and placing them back into hold modes. Therefore, for an E016 in the chain to count,

all of the lower order terminal count outputs must be in the low state. The bit width of the counter can be increased or decreased by simply adding or subtracting E016 devices from Figure 3 and maintaining the logic pattern illustrated in the same figure.

The maximum frequency of operation for the cascaded counter chain is set by the propagation delay of the TC\* output, the necessary setup time of the CE\* input, and the propagation delay through the OR gate controlling it (for 16-bit counters the limitation is only the TC\* propagation delay and the CE\* setup time). Figure 3 shows EL01 gates used to control the count enable inputs; however, if the frequency of operation is lower, a lower ECL OR gate can be used. Using the worst case guarantees for these parameters, the maximum count frequency for a greater than 16-bit counter is 500 MHz, and for a 16-bit counter is 625 MHz. Note that this assumes the trace delay between the TC\* outputs and the CE\* inputs are negligible. If this is not the case, estimates of these delays need to be added to the calculations.

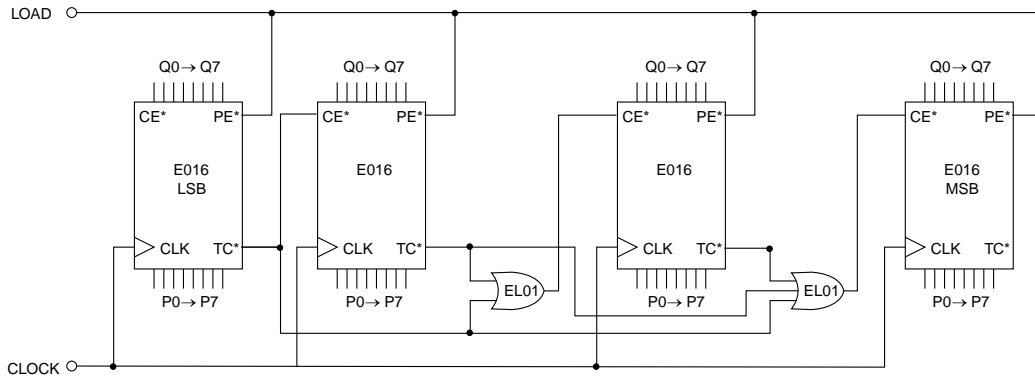

**Figure 3. 32-Bit Cascaded E016 Counter**

### Programmable Divider

The E016 has been designed with a control pin which makes it ideal for use as an 8-bit programmable divider. The TCLD pin (load on terminal count) when asserted reloads the data present at the parallel input pin (Pn's) upon reaching terminal count (an all 1s state on the outputs). Because this feedback is built internal to the chip, the programmable division operation will run at very nearly the same frequency as the maximum counting frequency of the device. Figure 4 below illustrates the input conditions necessary for utilizing the E016 as a programmable divider set up to divide by 113.

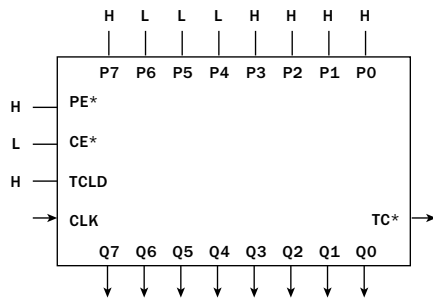

**Figure 4. Mod 2 to 256 Programmable Divider**

To determine what value to load into the device to accomplish the desired division, the designer simply subtracts the binary equivalent of the desired divide ratio from the binary value for 256. As an example for a divide ratio of 113:

$$Pn's = 256 - 113 = 8F_{16} = 1000\ 1111$$

where:  
 P0 = LSB and P7 = MSB

Forcing this input condition as per the setup in Figure 4 will result in the waveforms of Figure 5. Note that the TC\* output is used as the divide output and the pulse duration is equal to a full clock period. For even divide ratios, twice the desired divide ratio can be loaded into the E016, and the TC\* output can feed the clock input of a toggle flip-flop to create a signal divided as desired with a 50% duty cycle.

Divide Ratio	Preset Data Inputs							
	P7	P6	P5	P4	P3	P2	P1	P0
2	H	H	H	H	H	H	H	L
3	H	H	H	H	H	H	L	H
4	H	H	H	H	H	H	L	L
5	H	H	H	H	H	L	H	H
•	•	•	•	•	•	•	•	•
•	•	•	•	•	•	•	•	•
112	H	L	L	H	L	L	L	L
113	H	L	L	L	H	H	H	H
114	H	L	L	L	H	H	H	L
•	•	•	•	•	•	•	•	•
•	•	•	•	•	•	•	•	•
254	L	L	L	L	L	L	H	L
255	L	L	L	L	L	L	L	H
256	L	L	L	L	L	L	L	L

A single E016 can be used to divide by any ratio from 2 to 256 inclusive. If divide ratios of greater than 256 are needed, multiple E016s can be cascaded in a manner similar to that already discussed. When E016s are cascaded to build larger dividers, the TCLD pin will no longer provide a means for loading on terminal count. Because one does not want to reload the counters until all of the devices in the chain have reached terminal count, external gating of the TC\* pins must be used for multiple E016 divider chains.

Figure 6 shows a typical block diagram of a 32-bit divider chain. Once again, to maximize the frequency of operation, EL01 OR gates were used. For lower frequency applications, a slower OR gate could replace the EL01. Note that for a 16-bit divider, the OR function feeding the PE\* (program enable) input CANNOT be placed by a wire OR tie as the TC\* output of the least significant E016 must also feed the CE\* input of the most significant E016. If the two TC\* outputs were OR tied, the cascaded count operation would not operate properly. Because, in the cascaded form, the PE\* feedback is external and requires external gating, the maximum frequency of operation will be significantly less than the same operation in a single device.

### Maximizing E016 Count Frequency

The E016 device produces 9 fast transitioning single-ended outputs, thus VCC noise can become significant in situations where all of the outputs switch simultaneously in the same direction. This VCC noise can negatively impact the maximum frequency of operation of the device. Since the device does not need to have the Q outputs terminated to count properly, it is recommended that if the outputs are not going to be used in the rest of the system, they should be terminated. Not terminating the unused outputs will not only cut down the VCC noise generated, but will also save in total system power dissipation. Following these guidelines will allow designers to either be more aggressive in their designs or provide them with an extra margin to the published databook specifications.

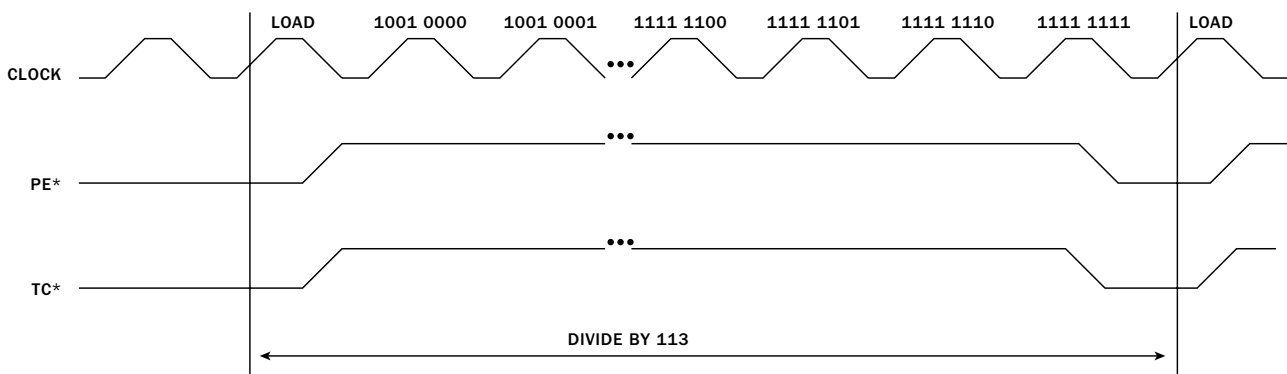

**Figure 5. Divide by 113 E016 Programmable Divider Waveforms**

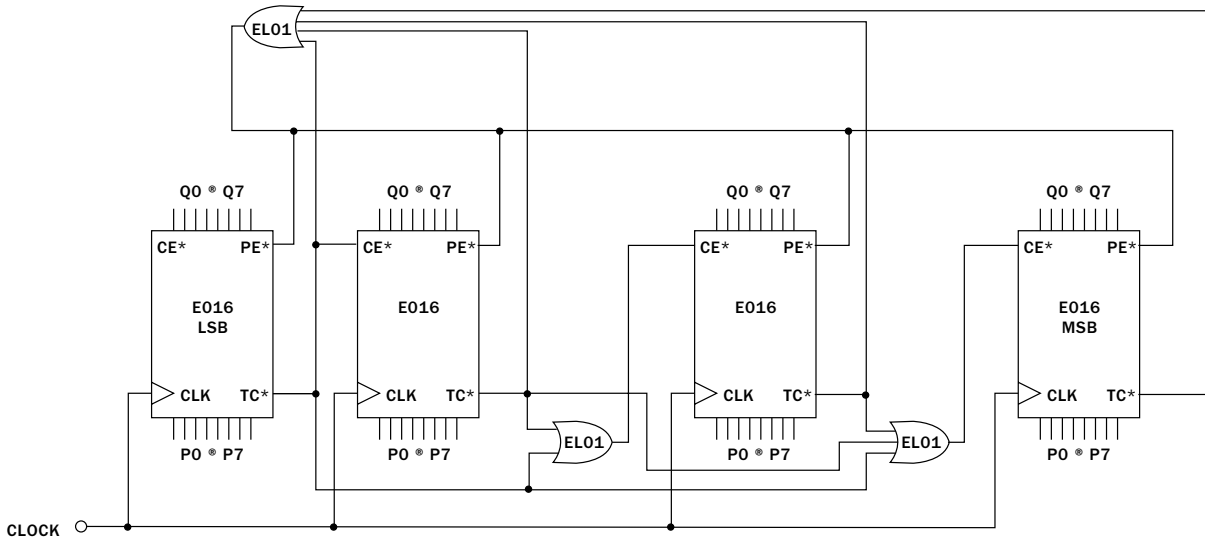

**Figure 6. 32-Bit Cascaded E016 Programmable Divider**

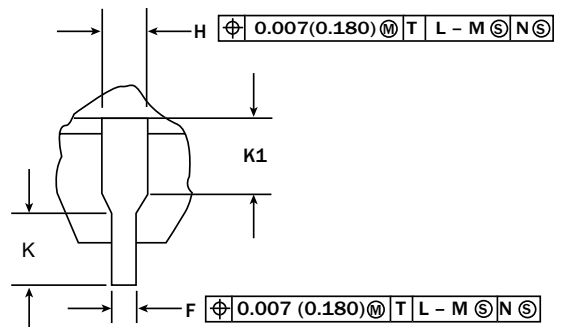
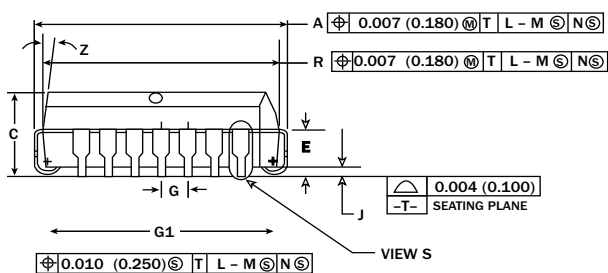
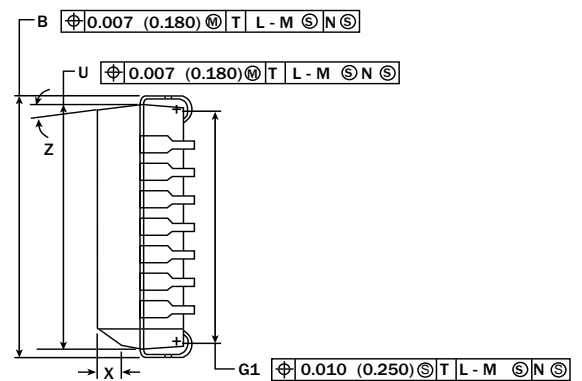
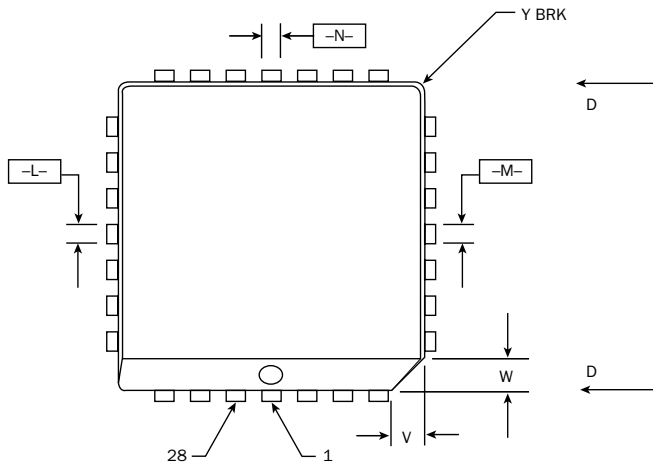
**NOTES:**

- Datums -L-, -M-, and -N- determined where top of lead shoulder exits plastic body at mold parting line.
- DIM G1, true position to be measured at Datum -T-, Seating Plane.
- DIM R and U do not include mold flash. Allowable mold flash is 0.010 (0.250) per side.
- Dimensioning and tolerancing per ANSI Y14.5M, 1982.
- Controlling Dimension: Inch.
- The package top may be smaller than the package bottom by up to 0.012 (0.300). Dimensions R and U are determined at the outermost extremes of the plastic body exclusive of mold flash, tie bar burrs, gate burrs and interlead flash, but including any mismatch between the top and bottom of the plastic body.
- Dimension H does not include Dambar protrusion or intrusion. The Dambar protrusion(s) shall not cause the H dimension to be greater than 0.037 (0.940). The Dambar intrusion(s) shall not cause the H dimension to be smaller than 0.025 (0.635).

DIM	INCHES		MILLIMETERS	
	MIN	MAX	MIN	MAX
A	0.485	0.495	12.32	12.57
B	0.485	0.495	12.32	12.57
C	0.165	0.180	4.20	4.57
E	0.090	0.110	2.29	2.79
F	0.013	0.019	0.33	0.48
G	0.050 BSC		1.27 BSC	
H	0.026	0.032	0.66	0.81
J	0.020	-	0.51	-
K	0.025	-	0.64	-
R	0.450	0.456	11.43	11.58
U	0.450	0.456	11.43	11.58
V	0.042	0.048	1.07	1.21
W	0.042	0.048	1.07	1.21
X	0.042	0.056	1.07	1.42
Y	-	0.020	-	0.50
Z	2°	10°	2°	10°
G1	0.410	0.430	10.42	10.92
K1	0.040	-	1.02	-

**HIGH-PERFORMANCE PRODUCTS**
**DC Characteristics**
**SK10/100E016 DC Electrical Characteristics (Notes 1, 2)**
**( $V_{CC} - V_{EE} = 4.2V$  to  $5.5V$ ;  $V_{CC} = V_{CC0}$ ;  $V_{OUT}$  Loaded  $50\Omega$  to  $V_{CC} - 2.0V$ )**

Symbol	Characteristic	TA = -40°C			TA = 0°C			TA = +25°C			TA = +85°C			Unit
		Min	Typ	Max	Min	Typ	Max	Min	Typ	Max	Min	Typ	Max	
I <sub>IH</sub>	Input HIGH Current			150			150			150			150	μA
I <sub>EE</sub>	Power Supply Current													
	10E		151	174		151	174		151	174		151	174	mA
	100E		151	185		151	185		151	185		151	185	mA

**AC Characteristics**
**SK10/100E016 AC Electrical Characteristics**
**( $V_{CC} - V_{EE} = 4.2V$  to  $5.5V$ ;  $V_{CC} = V_{CC0}$ ;  $V_{OUT}$  Loaded  $50\Omega$  to  $V_{CC} - 2.0V$ )**

Symbol	Characteristic	TA = -40°C			TA = 0°C			TA = +25°C			TA = +85°C			Unit
		Min	Typ	Max	Min	Typ	Max	Min	Typ	Max	Min	Typ	Max	
f <sub>COUNT</sub>	Maximum Count Frequency	700	900		700	900		700	900		700	900		MHz
t <sub>PLH</sub> t <sub>PHL</sub>	Propagation Delay to Output													
	CLK to Q	726	855	948	726	855	948	726	855	948	726	855	948	ps
	MR to Q	666	775	876	666	775	876	666	775	876	666	775	876	ps
	CLK to TC*	743	775	926	743	775	926	743	775	926	743	775	926	ps
	MR to TC*	656	738	820	656	738	820	656	738	820	656	738	820	ps
t <sub>s</sub>	Setup Time													
	Pn	150	-30		150	-30		150	-30		150	-30		ps
	CE*	600	400		600	400		600	400		600	400		ps
	PE*	600	400		600	400		600	400		600	400		ps
	TCLD	500	300		500	300		500	300		500	300		ps
t <sub>h</sub>	Hold Time													
	Pn	350	100		350	100		350	100		350	100		ps
	CE*	0	-400		0	-400		0	-400		0	-400		ps
	PE*	0	-400		0	-400		0	-400		0	-400		ps
	TCLD	100	-300		100	-300		100	-300		100	-300		ps
t <sub>RR</sub>	Reset Recovery Time	900	700		900	700		900	700		900	700		ps
t <sub>PW</sub>	Minimum Pulse Width CLK, MR	400			400			400			400			ps
t <sub>r</sub> , t <sub>f</sub>	Rise/Fall Times (20 - 80%)	231	306	559	231	306	559	235	318	526	244	330	460	ps

**Notes:**

- 10E circuits are designed to meet the DC specifications shown in the table after thermal equilibrium has been established. The circuit is in a test socket or mounted on a printed circuit board and transverse airflow greater than 500 lfpm is maintained.
- The same DC parameter values apply across the full V<sub>EE</sub> range of -4.2 to -5.5V. 100E circuits are designed to meet the DC specifications shown in the table where transverse airflow greater than 500 lfpm is maintained.
- For standard ECL DC specifications, refer to the ECL Logic Family Standard DC Specifications Data Sheet.
- For part ordering descriptions, see HPP Part Ordering Information Data Sheet.



**HIGH-PERFORMANCE PRODUCTS****Ordering Information**

<b>Ordering Code</b>	<b>Package ID</b>	<b>Temperature Range</b>
SK10E016PJ	28-PLCC	Industrial
SK10E016PJT	28-PLCC	Industrial
SK100E016PJ	28-PLCC	Industrial
SK100E016PJT	28-PLCC	Industrial

**Contact Information**

Division Headquarters  
10021 Willow Creek Road  
San Diego, CA 92131  
Phone: (858) 695-1808  
FAX: (858) 695-2633

**Semtech Corporation**  
**High-Performance Products Division**

Marketing Group  
1111 Comstock Street  
Santa Clara, CA 95054  
Phone: (408) 566-8776  
FAX: (408) 727-8994