

HIGH-PERFORMANCE PRODUCTS

Description

The SK10/100E116 is a quint differential line receiver designed for use in new, high-performance ECL systems.

The receiver design features clamp circuitry to cause a defined output state if both the inverting and non-inverting inputs are left open; in this case the Q output goes low, while the Q* output goes high. This feature makes the device ideal for twisted pair applications.

If both inverting and non-inverting inputs are at an equal potential of $>-2.9V$, the receiver does *not* go to a defined state, but rather shares current in normal differential amplifier fashion, producing output voltage levels midway between high and low. This may even cause the device to oscillate.

The SK10/100E116 provides VBB output for either single-ended use or as a DC bias for AC coupling to the device. The VBB output pin should be used only as a DC bias for the E116 as its current sink/source capability is limited. Whenever used, the VBB pin should be bypassed to VCC via a 0.01 μF capacitor.

Functional Block Diagram

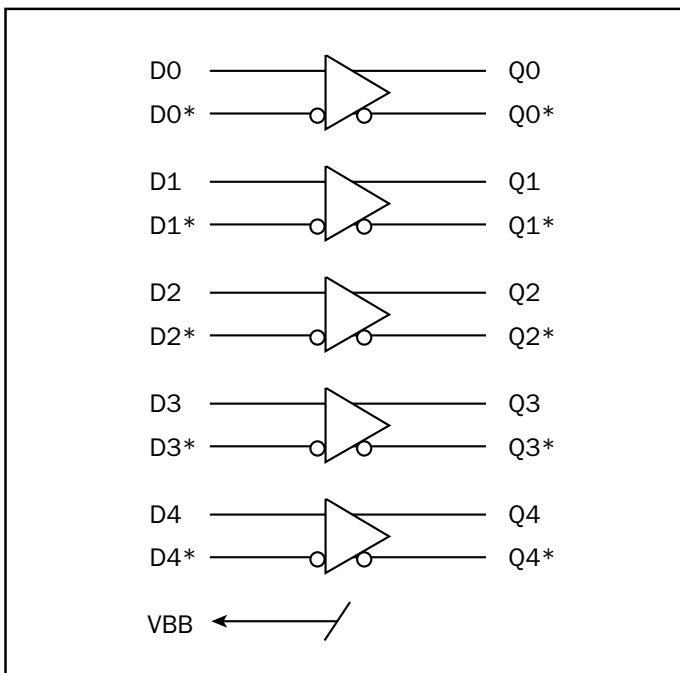

Features

- 500 ps Maximum Propagation Delay
- Extended VEE Range of $-4.2V$ to $-5.5V$
- VBB Output for Single-Ended Reception
- Internal $75K\Omega$ Input Pull-Down Resistors
- ESD Protection of $>4000V$
- Fully Compatible with MC10E/100E116
- Specified Over Industrial Temperature Range: $-40^\circ C$ to $+85^\circ C$
- Available in 28-Pin PLCC Package

PIN Description

Pin	Function
D0, D0*-D4, D4*	Differential Input Pairs
Q0, Q0*-Q4, Q4*	Differential Output Pairs
VBB	Reference Voltage Output
VCC0	VCC to Output

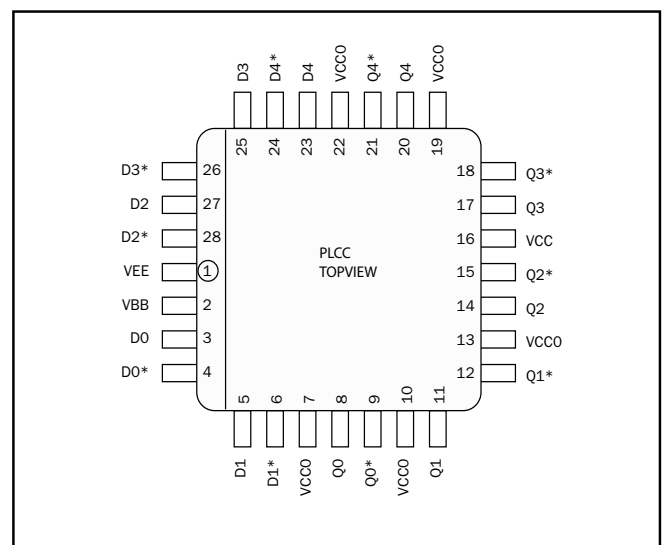

28-Pin PLCC Package

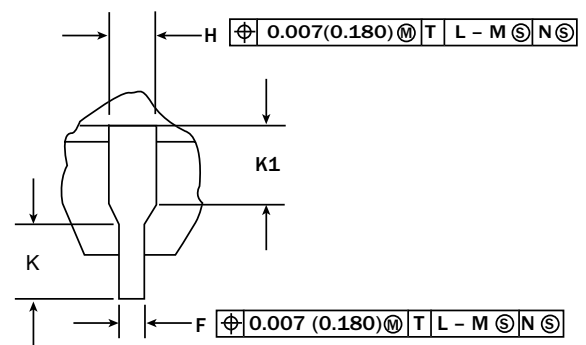
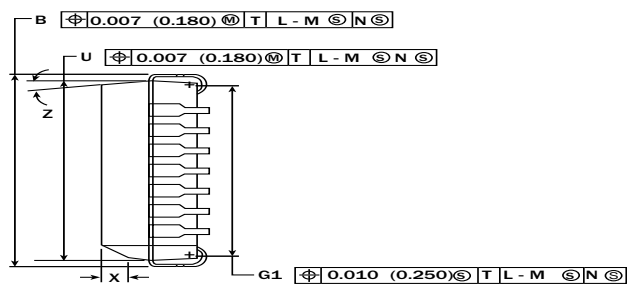
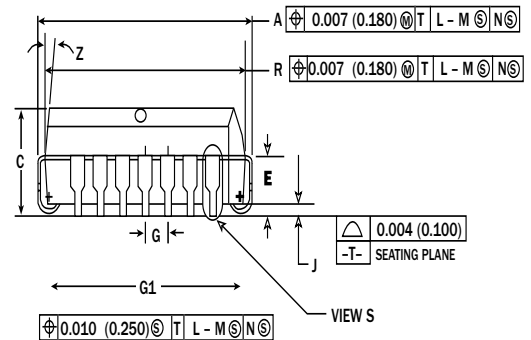
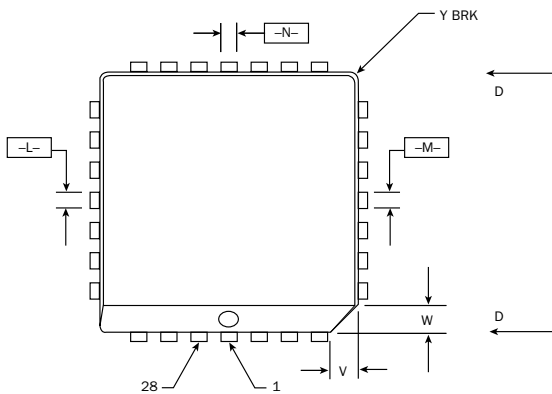

NOTES:

1. Datums -L-, -M-, and -N- determined where top of lead shoulder exits plastic body at mold parting line.
2. DIM G1, true position to be measured at Datum -T-, Seating Plane.
3. DIM R and U do not include mold flash. Allowable mold flash is 0.010 (0.250) per side.
4. Dimensioning and tolerancing per ANSI Y14.5M, 1982.
5. Controlling Dimension: Inch.
6. The package top may be smaller than the package bottom by up to 0.012 (0.300). Dimensions R and U are determined at the outermost extremes of the plastic body exclusive of mold flash, tie bar burrs, gate burrs and interlead flash, but including any mismatch between the top and bottom of the plastic body.
7. Dimension H does not include Dambar protrusion or intrusion. The Dambar protrusion(s) shall not cause the H dimension to be greater than 0.037 (0.940). The Dambar intrusion(s) shall not cause the H dimension to be smaller than 0.025 (0.635).

DIM	INCHES		MILLIMETERS	
	MIN	MAX	MIN	MAX
A	0.485	0.495	12.32	12.57
B	0.485	0.495	12.32	12.57
C	0.165	0.180	4.20	4.57
E	0.090	0.110	2.29	2.79
F	0.013	0.019	0.33	0.48
G	0.050	BSC	1.27	BSC
H	0.026	0.032	0.66	0.81
J	0.020	-	0.51	-
K	0.025	-	0.64	-
R	0.450	0.456	11.43	11.58
U	0.450	0.456	11.43	11.58
V	0.042	0.048	1.07	1.21
W	0.042	0.048	1.07	1.21
X	0.042	0.056	1.07	1.42
Y	-	0.020	-	0.50
Z	2°	10°	2°	10°
G1	0.410	0.430	10.42	10.92
K1	0.040	-	1.02	-

HIGH-PERFORMANCE PRODUCTS
DC Characteristics
SK10/100E116 DC Electrical Characteristics (Notes 1, 2)

 (V_{CC} - V_{EE} = 4.2V to 5.5V; V_{OUT} loaded 50Ω to V_{CC} - 2.0V)

Symbol	Characteristic	TA = -40°C			TA = 0°C			TA = +25°C			TA = +85°C			Unit
		Min	Typ	Max	Min	Typ	Max	Min	Typ	Max	Min	Typ	Max	
V _{BB}	Output Reference Voltage ⁹	10E	-1.43	-1.30	-1.38	-1.27	-1.35	-1.25	-1.31	-1.19	V			
		100E	-1.38	-1.26	-1.38	-1.26	-1.38	-1.26	-1.38	-1.26	V			
I _{IN}	Input Current	-200	200	-200	200	-200	200	-200	200	μA				
I _{EE}	Power Supply Current	10EL	35	35	35	35	35	35	35	mA				
		100EL	35	35	35	35	35	35	35	mA				
V _{CC} - V _{EE}	Power Supply Voltage	4.2	5.5	4.2	5.5	4.2	5.5	4.2	5.5	V				

AC Characteristics
SK10/100EL116 AC Electrical Characteristics

 (V_{CC} - V_{EE} = +4.2V to +5.5V ; V_{OUT} loaded 50Ω to V_{CC} - 2.0V)

Symbol	Characteristic	TA = -40°C			TA = 0°C			TA = +25°C			TA = +85°C			Unit
		Min	Typ	Max	Min	Typ	Max	Min	Typ	Max	Min	Typ	Max	
t _{PLH} t _{PHL}	Propagation Delay to Output D	365	445	385	505	310	530	315	495	ps				
t _{skew}	Within-Device Skew ⁶ DN to Qn, Qn*	50	50	50	50	ps								
t _{skew}	Duty Cycle Skew ⁷ t _{PLH} - t _{PHL}	±10	±10	±10	±10	ps								
V _{PP}	Minimum Input Swing CLK ³	150	1000	150	1000	150	1000	150	1000	mV				
t _r , t _f	Output Rise/Fall Times (20% to 80%)	190	580	210	580	210	580	210	580	ps				
V _{CMR}	Common Mode Range ⁴	V _{CC} - 2.0	V _{CC} - 0.6	V _{CC} - 2.0	V _{CC} - 0.6	V _{CC} - 2.0	V _{CC} - 0.6	V _{CC} - 2.0	V _{CC} - 0.6	V				

HIGH-PERFORMANCE PRODUCTS**AC Characteristics (continued)**

Notes:

1. 10EL circuits are designed to meet the DC specifications shown in the table after thermal equilibrium has been established. The circuit is in a test socket or mounted on a printed circuit board and transverse airflow greater than 500 lfpm is maintained. Outputs are terminated through a 50Ω resistor to $V_{CC}-2.0V$.
2. 100K circuits are designed to meet the DC specification shown in the table where transverse airflow greater than 500 lfpm is maintained.
3. Minimum input swing for which AC parameters guaranteed.
4. CMR range is referenced to the most positive side of the differential input signal. Normal operation is obtained if the high level falls within the specified range and the peak-to-peak voltage lies between $V_{PP(min)}$ and 1V. The lower end of the CMR range varies 1:1 with V_{CC} and is equal to $V_{CC} - 2.0V$.
5. Voltages referenced to $V_{CC} = 0V$ (ECL mode).
6. Within device skew is defined as identical transition on similar path through a device.
7. Duty cycle is defined only for differential operation when the delays are measured from the crosspoint of the inputs to the crosspoints of the outputs.
8. For standard ECL DC Specifications, refer to the ECL Logic Family Standard DC Specifications Data Sheet.
9. Voltages are referenced to $V_{CC} = 0V$ (ECL Mode).
10. For part ordering description, see HPP Part Ordering Information Data Sheet.

Ordering Information

Ordering Code	Package ID	Temperature Range
SK10E116PJ	28-PLCC	Industrial
SK10E116PJT	28-PLCC	Industrial
SK100E116PJ	28-PLCC	Industrial
SK100E116PJT	28-PLCC	Industrial

Contact Information

Division Headquarters
10021 Willow Creek Road
San Diego, CA 92131
Phone: (858) 695-1808
FAX: (858) 695-2633

Semtech Corporation
High-Performance Products Division

Marketing Group
1111 Comstock Street
Santa Clara, CA 95054
Phone: (408) 566-8776
FAX: (408) 727-8994