

HIGH-PERFORMANCE PRODUCTS

Description

The SK10E/100E142 is a 9-bit shift register, designed with byte-parity applications in mind. The E142 performs serial/parallel in and serial/parallel out, shifting in one direction. The nine inputs D0 – D8 accept parallel input data, while S-IN accepts serial input data. The Qn outputs do not need to be terminated for the shift operation to function. To minimize noise and power, any Q output not used should be left unterminated.

The SEL (Select) input pin is used to switch between the two modes of operation – SHIFT and LOAD. The shift direction is from bit 0 to bit 8. Input data is accepted by the registers at set-up time before the positive going edge of CLK1 or CLK2. Shifting is also accomplished on the positive clock edge. A HIGH on the Master Reset pin (MR) asynchronously resets all the registers to zero.

Features

- 700 MHz Minimum Shift Frequency
- 9-Bit for Byte-Parity Applications
- Asynchronous Master Reset
- Dual Clocks
- Extended 100E VEE Range of –4.2 to –5.5V
- 75KΩ Internal Input Pulldown Resistors
- Fully Compatible with MC10E142 and MC100E142
- Specified over Industrial Temperature Range: –40°C to 85°C
- ESD Protection of >4000V
- Available in 28-pin PLCC Package

Functional Block Diagram

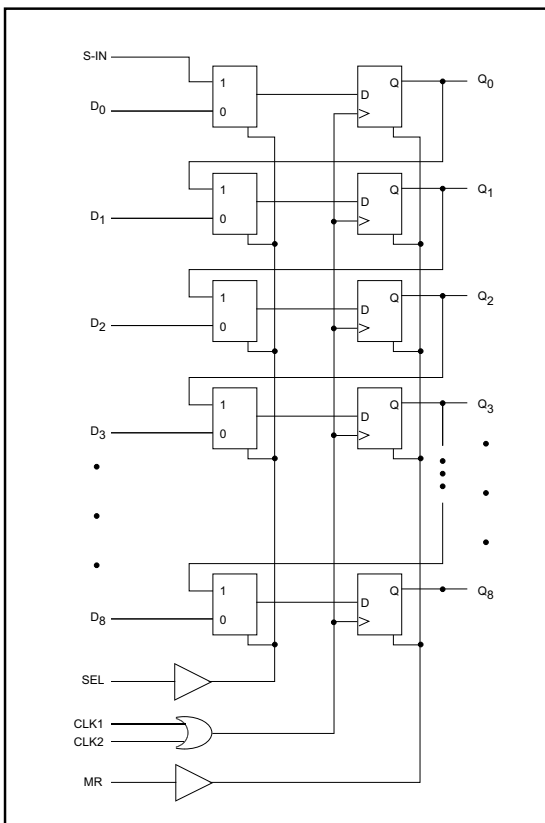

PIN Description

Pin Names

Pin	Function
D0 - D8	Parallel Data Inputs
S-IN	Serial Data Input
SEL	Mode Select Input
CLK1, CLK2	Clock Inputs
MR	Master Reset
Q0 - Q8	Data Outputs

Pinout

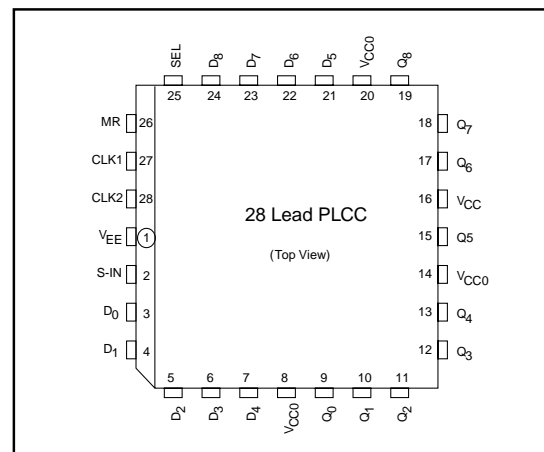

Functions

SEL	Mode
L	Load
H	Shift

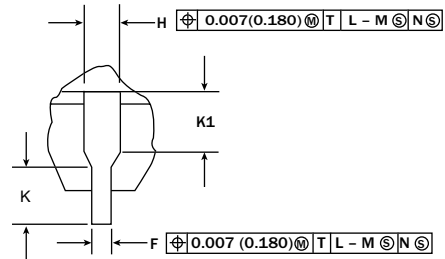
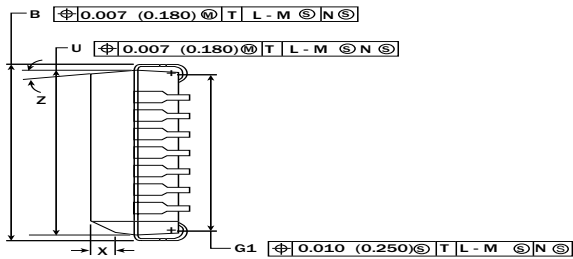
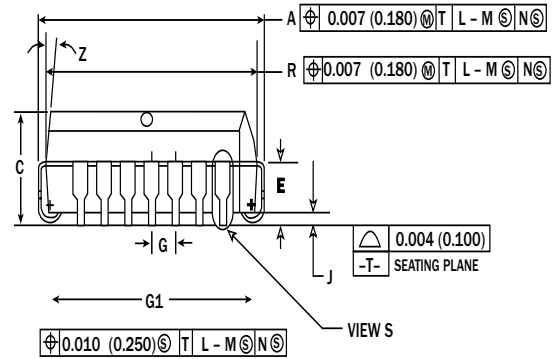
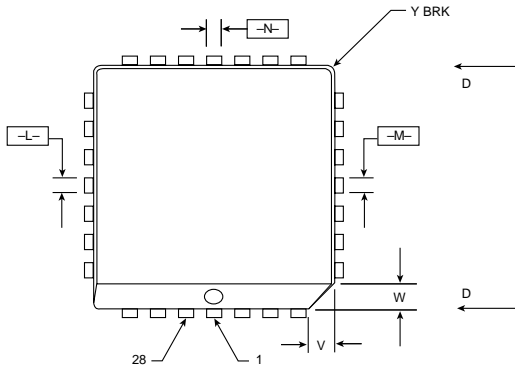
HIGH-PERFORMANCE PRODUCTS
Package Information

View S

NOTES:

- Datums -L-, -M-, and -N- determined where top of lead shoulder exits plastic body at mold parting line.
- DIM G1, true position to be measured at Datum -T-, Seating Plane.
- DIM R and U do not include mold flash. Allowable mold flash is 0.010 (0.250) per side.
- Dimensioning and tolerancing per ANSI Y14.5M, 1982.
- Controlling Dimension: Inch.
- The package top may be smaller than the package bottom by up to 0.012 (0.300). Dimensions R and U are determined at the outermost extremes of the plastic body exclusive of mold flash, tie bar burrs, gate burrs and interlead flash, but including any mismatch between the top and bottom of the plastic body.
- Dimension H does not include Dambar protrusion or intrusion. The Dambar protrusion(s) shall not cause the H dimension to be greater than 0.037 (0.940). The Dambar intrusion(s) shall not cause the H dimension to be smaller than 0.025 (0.635).

DIM	INCHES		MILLIMETERS	
	MIN	MAX	MIN	MAX
A	0.485	0.495	12.32	12.57
B	0.485	0.495	12.32	12.57
C	0.165	0.180	4.20	4.57
E	0.090	0.110	2.29	2.79
F	0.013	0.019	0.33	0.48
G	0.050 BSC		1.27 BSC	
H	0.026	0.032	0.66	0.81
J	0.020	-	0.51	-
K	0.025	-	0.64	-
R	0.450	0.456	11.43	11.58
U	0.450	0.456	11.43	11.58
V	0.042	0.048	1.07	1.21
W	0.042	0.048	1.07	1.21
X	0.042	0.056	1.07	1.42
Y	-	0.020	-	0.50
Z	2°	10°	2°	10°
G1	0.410	0.430	10.42	10.92
K1	0.040	-	1.02	-

HIGH-PERFORMANCE PRODUCTS
DC Characteristics
SK10/100E142 DC Electrical Characteristics (Notes 1, 2)
 $V_{CC} - V_{EE} = 4.2V$ to $5.5V$; V_{OUT} Loaded 50Ω to $V_{CC} - 2.0V$)

Symbol	Characteristic	TA = -40°C		TA = 0°C		TA = +25°C		TA = +85°C		Unit
		Min	Max	Min	Max	Min	Max	Min	Max	
I _{IH}	Input HIGH Current		150		150		150		150	μA
I _{EE}	Power Supply Current									
	10E	67	108	70	112	71	114	74	119	mA
	100E	69	112	74	120	78	125	86	138	mA

AC Characteristics
SK10/100E142 AC Electrical Characteristics
 $V_{CC} - V_{EE} = 4.2V$ to $5.5V$; V_{OUT} Loaded 50Ω to $V_{CC} - 2.0V$)

Symbol	Characteristic	TA = -40°C			TA = 0°C			TA = +25°C			TA = +85°C			Unit
		Min	Typ	Max	Min	Typ	Max	Min	Typ	Max	Min	Typ	Max	
f _{SHIFT}	Max. Shift Frequency	700	900		700	900		700	900		700	900		MHz
t _{PLH} t _{PHL}	Propagation Delay to Output													
	CLK	788		1053	795		1043	800		1037	813		1023	ps
	MR	831		989	836		994	840		987	851		976	ps
t _s	Setup Time													
	D	50			50			50			50			ps
	SEL	300			300			300			300			ps
t _H	Hold Time													
	D	300			300			300			300			ps
	SEL	75			75			75			75			ps
t _{RR}	Reset Recovery Time	900			900			900			900			ps
t _{PW}	Minimum Pulse Width													
	CLK, MR	400			400			400			400			ps
t _{SKEW}	Within Device Skew ³		50			50			50			50		ps
t _r t _f	Rise/Fall Times													
	(20% - 80%)	255		574	266		566	270		525	282		428	ps

HIGH-PERFORMANCE PRODUCTS**AC Characteristics (continued)***Notes:*

1. 10E circuits are designed to meet the DC specifications shown in the table after thermal equilibrium has been established. The circuit is in a test socket or mounted on a printed circuit board and transverse airflow greater than 500 lfpm is maintained. Outputs are terminated through a 50 Ω resistor to VCC-2.0V.
2. 100K circuits are designed to meet the DC specification shown in the table where transverse airflow greater than 500 lfpm is maintained.
3. Within device skew is defined as identical transitions on similar paths through a device.
4. For standard ECL DC specifications, refer to the ECL Logic Family Standard DC Specifications Data Sheet.
5. For part ordering description, see HPP Part Ordering Information Data Sheet.

Ordering Information

Ordering Code	Package ID	Temperature Range
SK10E142PJ	28-PLCC	Industrial
SK10E142PJT	28-PLCC	Industrial
SK100E142PJ	28-PLCC	Industrial
SK100E142PJT	28-PLCC	Industrial

Contact Information

Division Headquarters
10021 Willow Creek Road
San Diego, CA 92131
Phone: (858) 695-1808
FAX: (858) 695-2633

Semtech Corporation
High-Performance Products Division

Marketing Group
1111 Comstock Street
Santa Clara, CA 95054
Phone: (408) 566-8776
FAX: (408) 727-8994