

October 25, 1999

TEL:805-498-2111 FAX:805-498-3804 WEB:http://www.semtech.com

DESCRIPTION

The SC1172/3 combines a synchronous voltage mode controller with a low-dropout linear regulator providing most of the circuitry necessary to implement two DC/DC converters for powering advanced microprocessors such as Pentium® II (Klamath) or Deschutes.

The SC1172/3 switching section features an integrated 5 bit D/A converter, pulse by pulse current limiting, integrated power good signaling, and logic compatible shutdown. The SC1172/3 switching section operates at a fixed frequency of 200kHz, providing an optimum compromise between size, efficiency and cost in the intended application areas. The integrated D/A converter provides programmability of output voltage from 2.0V to 3.5V in 100mV increments and 1.30V to 2.05V in 50mV increments with no external components.

The SC1172/3 linear section is a high performance positive voltage regulator design for either the GTL bus supply at 1.5V (SC1172) or an adjustable output (SC1173).

The output of the linear regulator can provide up to 5A or more with the appropriate external MOSFET.

FEATURES

- Synchronous design, enables no heatsink solution
- 95% efficiency (switching section)
- 5 bit DAC for output programmability
- On chip power good function
- Designed for Intel Pentium® II VRM8.1 requirements
- 1.5V or Adj. @ 1% for linear section

APPLICATIONS

- Pentium® II or Deschutes microprocessor supplies
- Flexible motherboards
- 1.3V to 3.5V microprocessor supplies
- Programmable dual power supplies

ORDERING INFORMATION

Part Number ⁽¹⁾	Package	Linear Voltage	Temp. Range (T _J)
SC1172CSW	SO-24	1.5V	0° to 125°C
SC1173CSW	SO-24	Adj.	0° to 125°C

Note:

(1) Add suffix 'TR' for tape and reel.

PIN CONFIGURATION

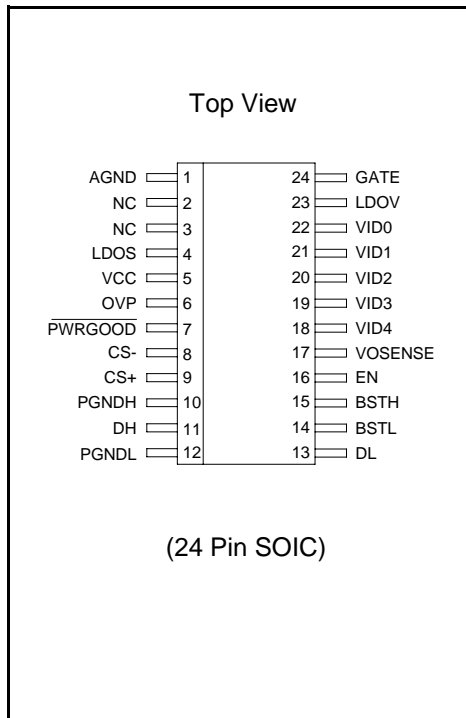

BLOCK DIAGRAM

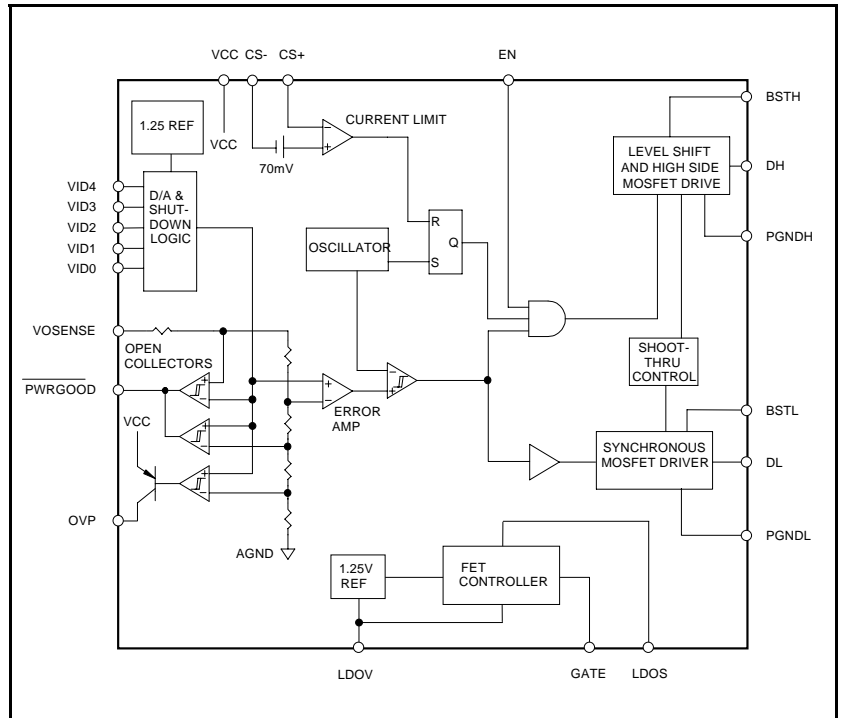



October 25, 1999

ABSOLUTE MAXIMUM RATINGS

Parameter	Symbol	Maximum	Units
V _{CC} to GND	V _{IN}	-0.3 to +7	V
PGND to GND		± 1	V
BST to GND		-0.3 to +15	V
Operating Temperature Range	T _A	0 to +70	°C
Junction Temperature Range	T _J	0 to +125	°C
Storage Temperature Range	T _{STG}	-65 to +150	°C
Lead Temperature (Soldering) 10 seconds	T _L	300	°C
Thermal Impedance Junction to Ambient	θ _{JA}	80	°C/W
Thermal Impedance Junction to Case	θ _{JC}	25	°C/W

ELECTRICAL CHARACTERISTICS

Unless specified: V_{CC} = 4.75V to 5.25V; GND = P_{GND} = 0V; V_{OSENSE} = V_O; 0mV < (CSp-CSm) < 60mV; LDOV = 11.4V to 12.6V; T_A = 25°C

PARAMETER	CONDITIONS	MIN	TYP	MAX	UNITS
Switching Section					
Output Voltage	I _O = 2A	See Note 1.			
Supply Voltage	V _{CC}	4.2		7	V
Supply Current	V _{CC} = 5.0		8	15	mA
Load Regulation	I _O = 0.8A to 15A		1		%
Line Regulation			0.5		%
Minimum operating voltage				4.2	V
Current Limit Voltage		60	70	80	mV
Oscillator Frequency		180	200	220	kHz
Oscillator Max Duty Cycle		90	95		%
DH Sink/Source Current	BSTH-DH = 4.5V, DH-PGNDH = 2V	1			A
DL Sink/Source Current	BSTL-DL = 4.5V, DL-PGNDL = 2V	1			A
Output Voltage Tempco			30	100	ppm/°C
Gain (A _{OL})	V _{OSENSE} to V _O		35		dB
OVP threshold voltage			120		%
OVP source current	V _{OVP} = 3.0V	10			mA
Power good threshold voltage		88		112	%
Dead time		50	100		ns
Linear Section					
Quiescent current	LDOV = 12V			5	mA
Output Voltage (SC1172)		1.485	1.500	1.515	V
Reference Voltage (SC1173)		1.252	1.265	1.278	V
Feedback Pin Bias Current (SC1173)				10	uA
Gain (A _{OL})	LDOS to GATE		90		dB
Load Regulation	I _O = 0 to 8A ⁽²⁾			0.3	%
Line Regulation				0.3	%
Output Impedance			200		Ω

Notes: (1) See Output Voltage table
(2) In application circuit

October 25, 1999

PIN DESCRIPTION

Pin	Pin Name	Pin Function
1	AGND	Small Signal Analog and Digital Ground
2	NC	No connection
3	NC	No Connection
4	LDOS	Sense Input for LDO
5	VCC	Input Voltage
6	OVP	High Signal out if $V_o > \text{setpoint} + 20\%$
7	PWRGOOD ⁽¹⁾	Open collector logic output, high if V_o within 10% of setpoint
8	CS-	Current Sense Input (negative)
9	CS+	Current Sense Input (positive)
10	PGNDH	Power Ground for High Side Switch
11	DH	High Side Driver Output
12	PGNDL	Power Ground for Low Side Switch
13	DL	Low Side Driver Output
14	BSTL	Supply for Low Side Driver
15	BSTH	Supply for High Side Driver
16	EN ⁽¹⁾	Logic low shuts down the converter; High or open for normal operation.
17	VOSENSE	Top end of internal feedback chain
18	VID4 ⁽¹⁾	Programming Input (MSB)
19	VID3 ⁽¹⁾	Programming Input
20	VID2 ⁽¹⁾	Programming Input
21	VID1 ⁽¹⁾	Programming Input
22	VID0 ⁽¹⁾	Programming Input (LSB)
23	LDOV	+12V for LDO section
24	GATE	Gate Drive Output LDO

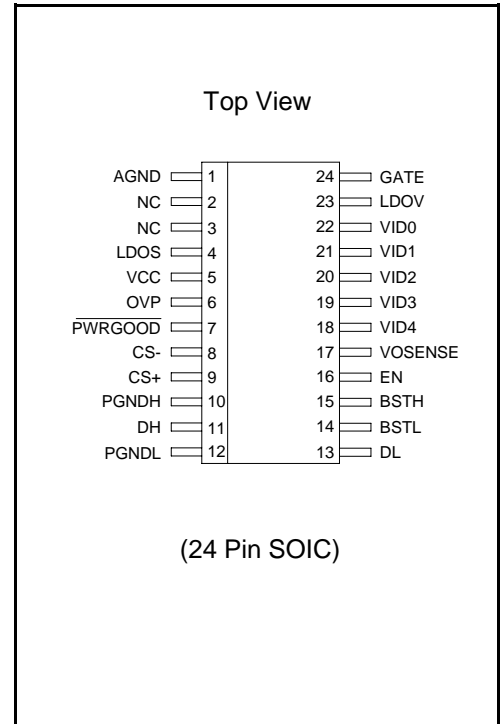

Note:

(1) All logic level inputs and outputs are open collector TTL compatible.



October 25, 1999

OUTPUT VOLTAGE

Unless specified: $V_{CC} = 4.75V$ to $5.25V$; $GND = PGND = 0V$; $V_{OSENSE} = V_O$; $0mV < (C_{Sp}-C_{Sm}) < 60mV$; $T_A = 25^{\circ}C$

PARAMETER	CONDITIONS	VID	MIN	TYP	MAX	UNITS
Output Voltage	$I_o = 2A$ in Application Circuit	43210				
		01111	1.287	1.300	1.313	V
		01110	1.336	1.350	1.364	
		01101	1.386	1.400	1.414	
		01100	1.435	1.450	1.465	
		01011	1.485	1.500	1.515	
		01010	1.534	1.550	1.566	
		01001	1.584	1.600	1.616	
		01000	1.633	1.650	1.667	
		00111	1.683	1.700	1.717	
		00110	1.732	1.750	1.768	
		00101	1.782	1.800	1.818	
		00100	1.831	1.850	1.869	
		00011	1.881	1.900	1.919	
		00010	1.930	1.950	1.970	
		00001	1.980	2.000	2.020	
		00000	2.029	2.050	2.071	
		11111	1.980	2.000	2.020	
		11110	2.079	2.100	2.121	
		11101	2.178	2.200	2.222	
		11100	2.277	2.300	2.323	
		11011	2.376	2.400	2.424	
		11010	2.475	2.500	2.525	
		11001	2.574	2.600	2.626	
		11000	2.673	2.700	2.727	
		10111	2.772	2.800	2.828	
		10110	2.871	2.900	2.929	
		10101	2.970	3.000	3.030	
		10100	3.069	3.100	3.131	
		10011	3.168	3.200	3.232	
		10010	3.267	3.300	3.333	
		10001	3.366	3.400	3.434	
10000	3.465	3.500	3.535			

October 25, 1999

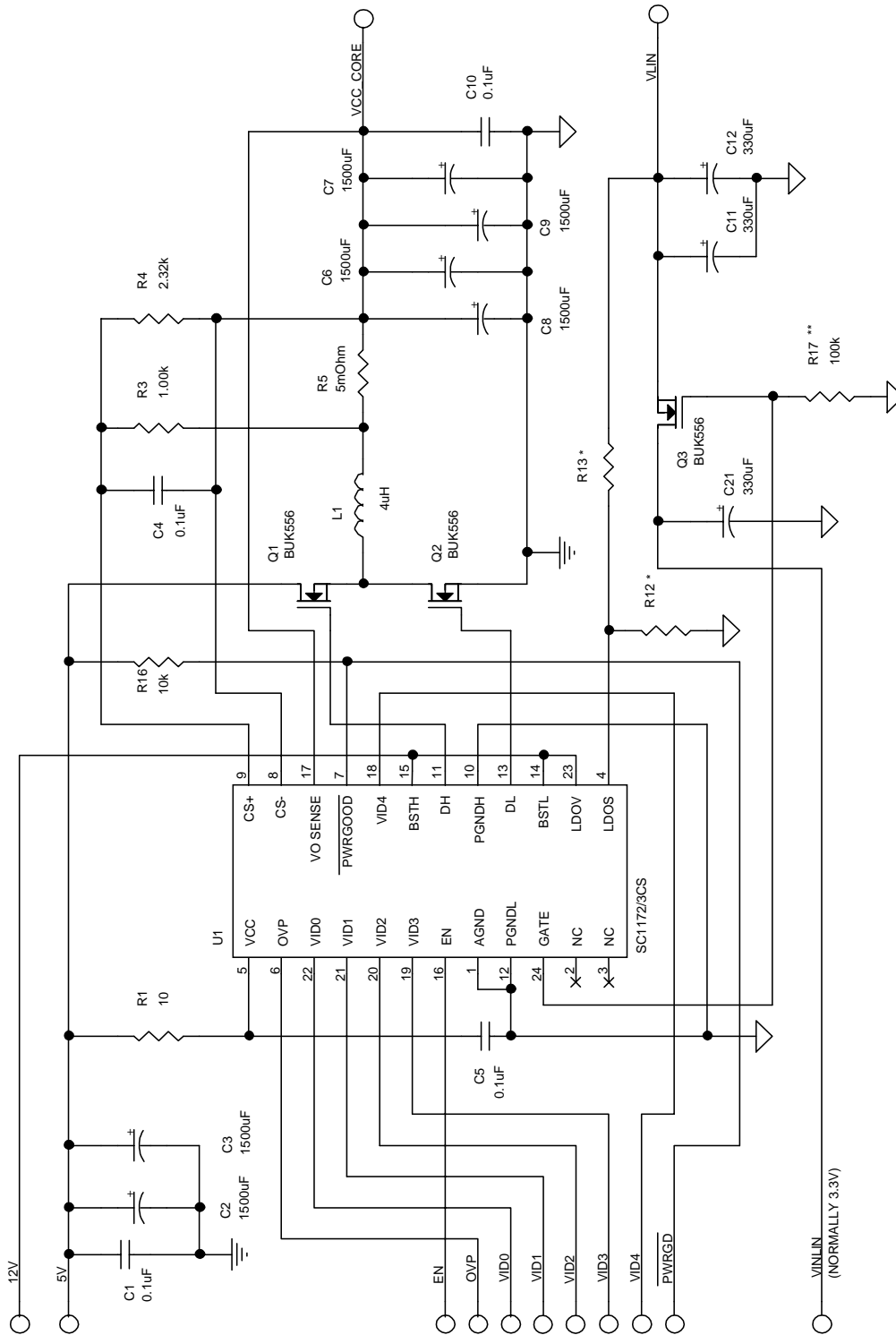
APPLICATION CIRCUIT

NOTE: FOR SC1172, R12 AND R13 ARE NOT REQUIRED.
 CONNECT LDOS (PIN4) DIRECTLY TO VLIN TO
 GENERATE 1.5V TO OUTPUT.
 * SEE "SETTING LDO OUTPUT VOLTAGE" TABLE.
 ** R17 REQUIRED IF VLIN CAN BE PRESENT
 WITHOUT 12V BEING PRESENT.

October 25, 1999

MATERIALS LIST

Qty.	Reference	Part/Description	Vendor	Notes
4	C1,C5,C13,C18	0.1µF Ceramic	Various	
6	C2,C3,C14-C17	1500µF/6.3V	SANYO	MV-GX or equiv. Low ESR
3	C11,C12,C21	330µF/6.3V	Various	
1	L1	4µH		8 Turns 16AWG on MICROMETALS T50-52D core
3	Q1,Q2,Q3	See notes	See notes	FET selection requires trade-off between efficiency and cost. Absolute maximum $R_{DS(ON)} = 22 \text{ m}\Omega$ for Q1,Q2
1	R4	5mΩ	IRC	OAR-1 Series
1	R5	2.32kΩ, 1%, 1/8W	Various	
1	R6	1kΩ, 1%, 1/8W	Various	
1	R1	10Ω, 5%, 1/8W	Various	
1	R12	1%, 1/8W	Various	See Table (Not required for SC1172)
1	R13	1%, 1/8W	Various	See Table (Not required for SC1172)
1	R17	100K, 5% 1/8W	Various	
1	U1	SC1172/3CSW	SEMTECH	

SETTING LDO OUTPUT VOLTAGE

	R_B	R_A
V_O LDO	R12	R13
3.45V	105Ω	182Ω
3.30V	105Ω	169Ω
3.10V	102Ω	147Ω
2.90V	100Ω	130Ω
2.80V	100Ω	121Ω
2.50V	100Ω	97.6Ω
1.50V	100Ω	18.7Ω

$$V_{OUT} = \frac{1.265 \cdot (R_A + R_B)}{R_B} + (I_{FB} \cdot R_A)$$

Where :

 I_{FB} = Feedback pin bias current

 R_A = Top feedback resistor

 R_B = Bottom feedback resistor

See layout diagram for clarification

 R_A and R_B must be low enough so that the $(I_{FB} \cdot R_A)$ term does not cause significant error

October 25, 1999

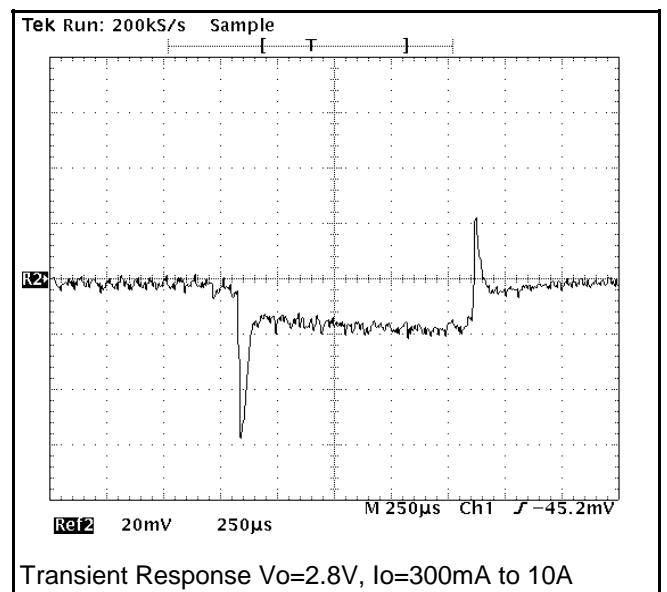
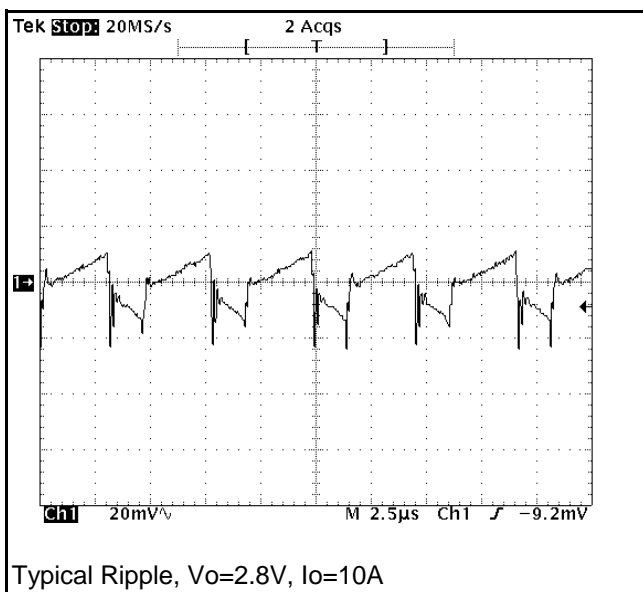
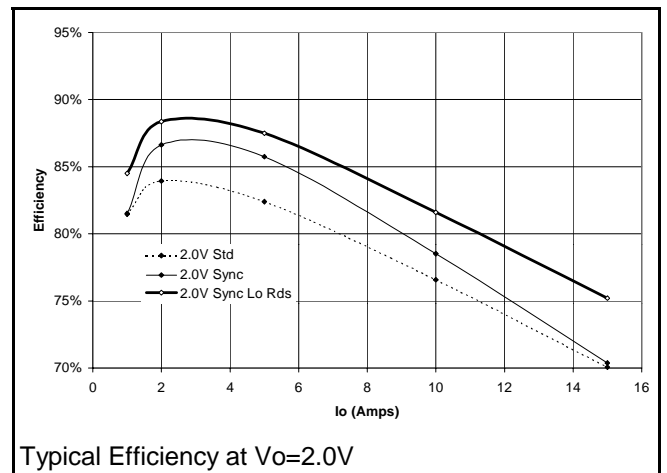
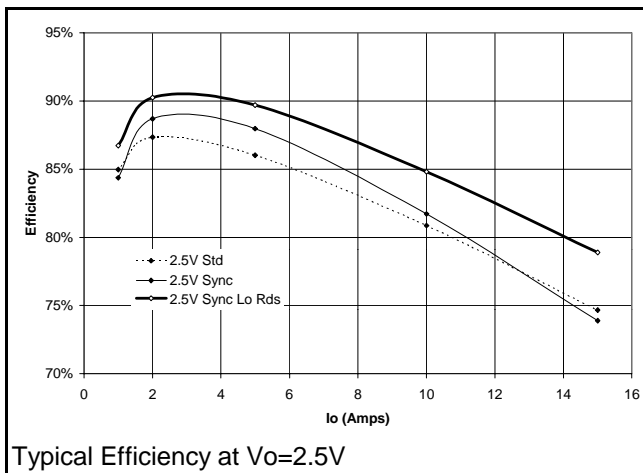
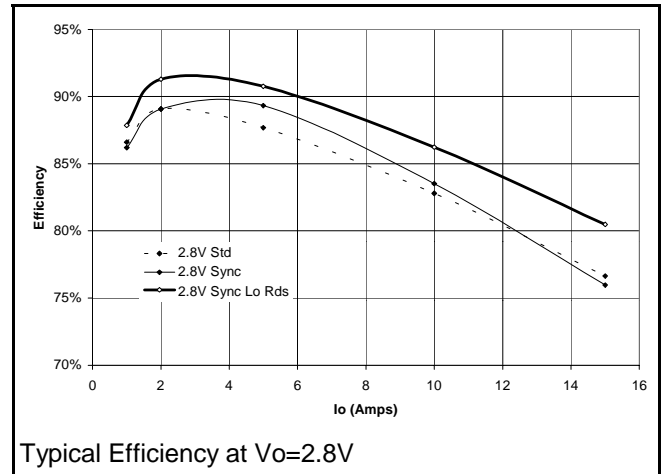
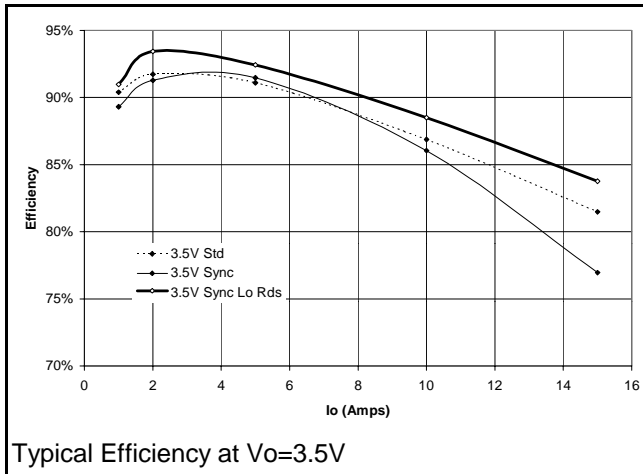

October 25, 1999

LAYOUT GUIDELINES

Careful attention to layout requirements are necessary for successful implementation of the SC1172/3 PWM controller. High currents switching at 200kHz are present in the application and their effect on ground plane voltage differentials must be understood and minimized.

1). The high power parts of the circuit should be laid out first. A ground plane should be used, the number and position of ground plane interruptions should be such as to not unnecessarily compromise ground plane integrity. Isolated or semi-isolated areas of the ground plane may be deliberately introduced to constrain ground currents to particular areas, for example the input capacitor and bottom FET ground.

2). The loop formed by the Input Capacitor(s) (Cin), the Top FET (Q1) and the Bottom FET (Q2) must be kept

as small as possible. This loop contains all the high current, fast transition switching. Connections should be as wide and as short as possible to minimize loop inductance. Minimizing this loop area will a) reduce EMI, b) lower ground injection currents, resulting in electrically "cleaner" grounds for the rest of the system and c) minimize source ringing, resulting in more reliable gate switching signals.

3). The connection between the junction of Q1, Q2 and the output inductor should be a wide trace or copper region. It should be as short as practical. Since this connection has fast voltage transitions, keeping this connection short will minimize EMI. The connection between the output inductor and the sense resistor should be a wide trace or copper area, there are no fast voltage or current transitions in this connection and length is not so important, however adding unnecessary impedance will reduce efficiency.

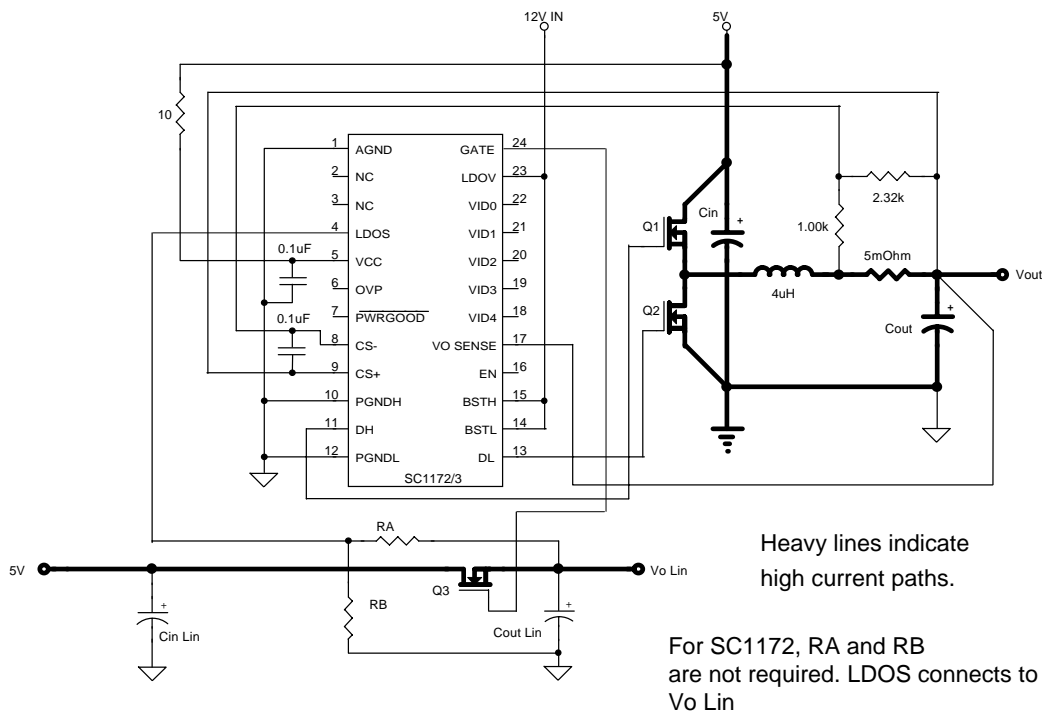

Layout diagram for the SC1172/3

October 25, 1999

4) The Output Capacitor(s) (C_{out}) should be located as close to the load as possible, fast transient load currents are supplied by C_{out} only, and connections between C_{out} and the load must be short, wide copper areas to minimize inductance and resistance.

5) The SC1172/3 is best placed over a quite ground plane area, avoid pulse currents in the C_{in} , Q1, Q2 loop flowing in this area. PGNDH and PGNDL should be returned to the ground plane close to the package. The AGND pin should be connected to the ground side of (one of) the output capacitor(s). If this is not possible, the AGND pin may be connected to the ground path between the Output Capacitor(s) and the C_{in} , Q1, Q2 loop. Under no circumstances should AGND be returned to a ground inside the C_{in} , Q1, Q2 loop.

6) V_{cc} for the SC1172/3 should be supplied from the

5V supply through a 10Ω resistor, the V_{cc} pin should be decoupled directly to AGND by a $0.1\mu F$ ceramic capacitor, trace lengths should be as short as possible.

7) The Current Sense resistor and the divider across it should form as small a loop as possible, the traces running back to CS+ and CS- on the SC1172/3 should run parallel and close to each other. The $0.1\mu F$ capacitor should be mounted as close to the CS+ and CS- pins as possible.

8) Ideally, the ground for the LDO section should be returned to the ground side of (one of) the switching section output capacitor(s).

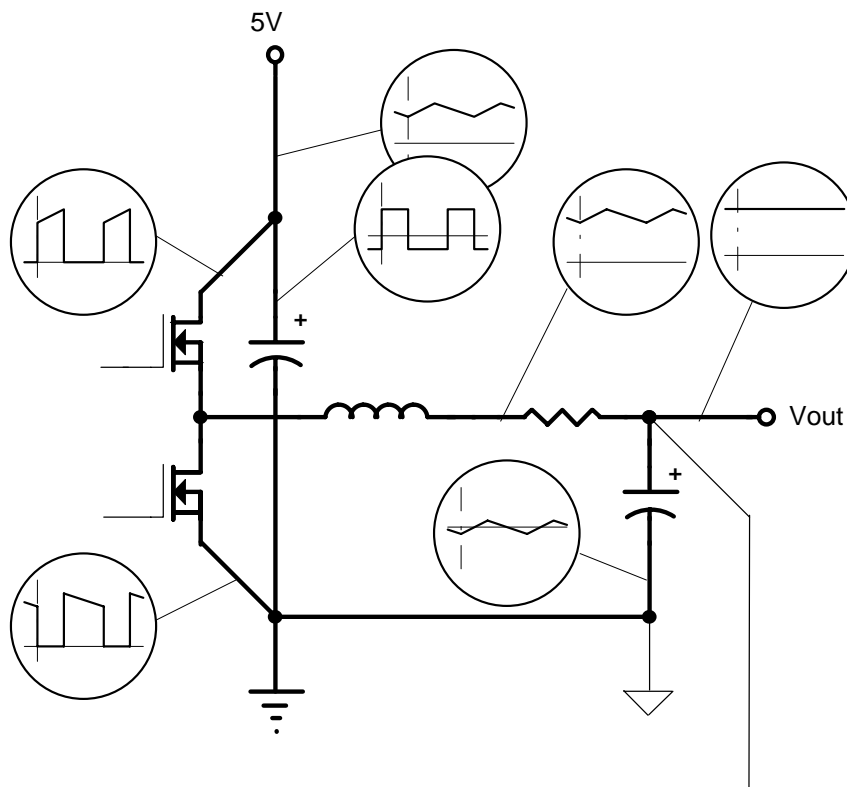

Currents in various parts of the power section

October 25, 1999

COMPONENT SELECTION

SWITCHING SECTION

OUTPUT CAPACITORS - Selection begins with the most critical component. Because of fast transient load current requirements in modern microprocessor core supplies, the output capacitors must supply all transient load current requirements until the current in the output inductor ramps up to the new level. Output capacitor ESR is therefore one of the most important criteria. The maximum ESR can be simply calculated from:

$$R_{ESR} \leq \frac{V_t}{I_t}$$

Where

V_t = Maximum transient voltage excursion

I_t = Transient current step

For example, to meet a 100mV transient limit with a 10A load step, the output capacitor ESR must be less than 10mΩ. To meet this kind of ESR level, there are three available capacitor technologies:

Technology	Each Capacitor		Qty. Rqd.	Total	
	C (μF)	ESR (mΩ)		C (μF)	ESR (mΩ)
Low ESR Tantalum	330	60	6	2000	10
OS-CON	330	25	3	990	8.3
Low ESR Aluminum	1500	44	5	7500	8.8

The choice of which to use is simply a cost /performance issue, with Low ESR Aluminum being the cheapest, but taking up the most space.

INDUCTOR - Having decided on a suitable type and value of output capacitor, the maximum allowable value of inductor can be calculated. Too large an inductor will produce a slow current ramp rate and will cause the output capacitor to supply more of the transient load current for longer - leading to an output voltage sag below the ESR excursion calculated above. The maximum inductor value may be calculated from:

$$L \leq \frac{R_{ESR} C}{I_t} (V_{IN} - V_O)$$

The calculated maximum inductor value assumes 100% duty cycle, so some allowance must be made. Choosing an inductor value of 50 to 75% of the calculated maximum will guarantee that the inductor current will ramp

fast enough to reduce the voltage dropped across the ESR at a faster rate than the capacitor sags, hence ensuring a good recovery from transient with no additional excursions.

We must also be concerned with ripple current in the output inductor and a general rule of thumb has been to allow 10% of maximum output current as ripple current. Note that most of the output voltage ripple is produced by the inductor ripple current flowing in the output capacitor ESR. Ripple current can be calculated from:

$$I_{RIPPLE} = \frac{V_{IN}}{4 \cdot L \cdot f_{OSC}}$$

Ripple current allowance will define the minimum permitted inductor value.

POWER FETS - The FETs are chosen based on several criteria with probably the most important being power dissipation and power handling capability.

TOP FET - The power dissipation in the top FET is a combination of conduction losses, switching losses and bottom FET body diode recovery losses.

a) Conduction losses are simply calculated as:

$$P_{COND} = I_O^2 \cdot R_{DS(on)} \cdot \delta$$

where

$$\delta = \text{duty cycle} \approx \frac{V_O}{V_{IN}}$$

b) Switching losses can be estimated by assuming a switching time, if we assume 100ns then:

$$P_{SW} = I_O \cdot V_{IN} \cdot 10^{-2}$$

or more generally,

$$P_{SW} = \frac{I_O \cdot V_{IN} \cdot (t_r + t_f) \cdot f_{OSC}}{4}$$

c) Body diode recovery losses are more difficult to estimate, but to a first approximation, it is reasonable to assume that the stored charge on the bottom FET body diode will be moved through the top FET as it starts to turn on. The resulting power dissipation in the top FET will be:

$$P_{RR} = Q_{RR} \cdot V_{IN} \cdot f_{OSC}$$

To a first order approximation, it is convenient to only consider conduction losses to determine FET suitability. For a 5V in; 2.8V out at 14.2A requirement, typical FET losses would be:

October 25, 1999

FET type	R _{DS(on)} (mΩ)	P _D (W)	Package
BUK556H	22	2.48	TO220
IRL2203	7.0	0.79	D ² PAK
Si4410	13.5	1.53	SO-8

BOTTOM FET - Bottom FET losses are almost entirely due to conduction. The body diode is forced into conduction at the beginning and end of the bottom switch conduction period, so when the FET turns on and off, there is very little voltage across it, resulting in low switching losses. Conduction losses for the FET can be determined by:

$$P_{COND} = I_O^2 \cdot R_{DS(on)} \cdot (1 - \delta)$$

For the example above:

FET type	R _{DS(on)} (mΩ)	P _D (W)	Package
BUK556H	22	1.95	TO220
IRL2203	7.0	0.62	D ² PAK
Si4410	13.5	1.20	SO-8

Each of the package types has a characteristic thermal impedance, for the TO-220 package, thermal impedance is mostly determined by the heatsink used. For the surface mount packages on double sided FR4, 2 oz printed circuit board material, thermal impedances of 40°C/W for the D²PAK and 80°C/W for the SO-8 are readily achievable. The corresponding temperature rise is detailed below:

FET type	Temperature rise (°C)	
	Top FET	Bottom FET
BUK556H	49.6 ⁽¹⁾	39.0 ⁽¹⁾
IRL2203	31.6	24.8
Si4410	122.4	96
(1) With 20°C/W Heatsink		

It is apparent that single SO-8 Si4410 are not adequate for this application, but by using parallel pairs in each position, power dissipation will be approximately halved and temperature rise reduced by a factor of 4.

INPUT CAPACITORS - since the RMS ripple current in the input capacitors may be as high as 50% of the output current, suitable capacitors must be chosen accordingly. Also, during fast load transients, there may be restrictions on input di/dt. These restrictions require useable energy storage within the converter circuitry, either as extra output capacitance or, more usually, additional input capacitors. Choosing low ESR input capacitors will help maximize ripple rating for a given size.

October 25, 1999

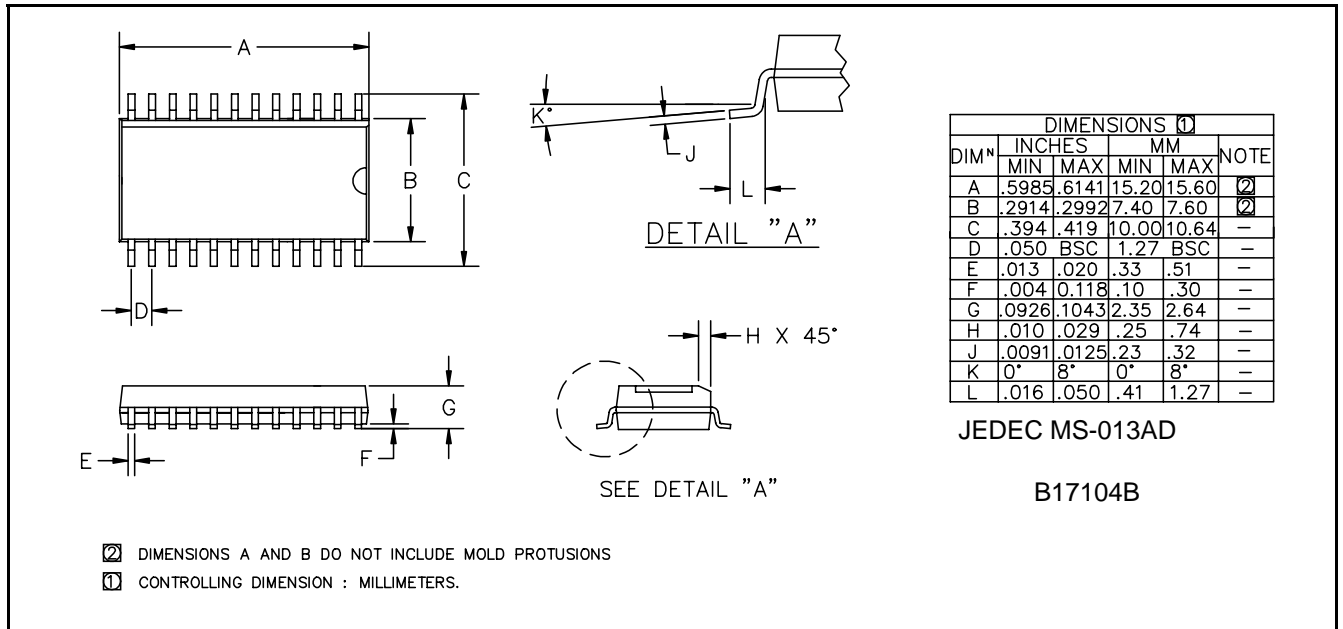
OUTLINE DRAWING

ECN99-667