

March 17, 1998

 TEL:805-498-2111 FAX:805-498-3804 WEB:<http://www.semtech.com>

DESCRIPTION

The LP2951A is an improved version of the LP2951 and features tighter tolerance on the output voltage and reference voltage specifications. Both the LP2951 and LP2951A feature 150mA output current capability. The LP2951 series of low power voltage regulators have low quiescent current and low dropout voltage. The quiescent current increases minimally during dropout conditions thereby extending battery life.

Available in the eight lead SOIC package, the LP2951 series includes features such as shutdown and low output voltage detect (typically due to low battery conditions). This function may also be used as a power on reset function when triggered by CMOS or TTL inputs. The circuit can be used as a fixed voltage 5 volt regulator or adjusted between 1.24 volts and 29 volts using external resistor pairs.

FEATURES

- Guaranteed 150mA current
- Adjustable output voltage - 1.24V to 29V
- Accurate 5V output @ 150mA
- Low dropout voltage - 450mV @ 150mA
- Regulator or reference functions
- Direct replacement for LP2951AC, MIC2951-02, AS2951AC

APPLICATIONS

- Microcontroller supplies
- Linear regulators
- Adjustable supplies
- Switching power supplies - post-regulation
- Portable modems
- Battery powered systems
- Cellular telephones
- Voltage references

BLOCK DIAGRAM

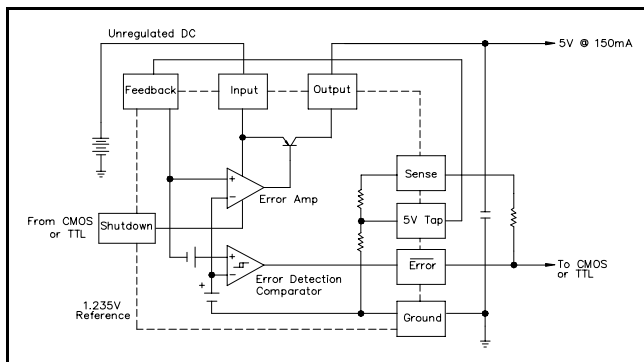

PIN CONFIGURATION

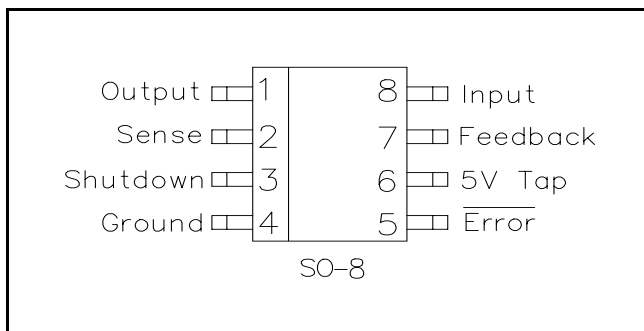

ORDERING INFORMATION

DEVICE ⁽¹⁾	V _{OUT} VOLTS	PACKAGE
LP2951ACM	ADJ	SO-8

Note:

(1) Add suffix 'TR' for tape and reel.

ABSOLUTE MAXIMUM RATINGS

Parameter	Symbol	Maximum	Units
Supply Voltage	V _{IN}	-0.3 to 30	V
Shutdown Input Voltage		-0.3 to 30	V
Error Comp. Output Voltage		-0.3 to 30	V
Power Dissipation	P _D	Internally Limited	W
Operating Junction Temperature Range	T _J	-40 to 125	°C
Storage Temperature Range	T _{STG}	-65 to 150	°C
Lead Temperature (Soldering) 5 Sec	T _{LEAD}	260	°C

March 17, 1998

ELECTRICAL CHARACTERISTICS

 Unless specified, limits are over operating temperature range ($T_J = T_A$), $V_{IN} = V_{OUT(NOM)} + 1V$, $I_L = 100\mu A$, $C_L = 1\mu F$

Parameter	Symbol	Conditions	Min	Typ	Max	Units
Output Voltage	V_{OUT}	$T_J = 25^\circ C$, $I_L = 100\mu A$	4.975	5.000	5.025	V
Temp Coefficient ⁽¹⁾	T_C	$0^\circ C \leq T_J \leq 70^\circ C$		20	120	ppm/ $^\circ C$
Line Regulation	$REG_{(LINE)}$	$6V \leq V_{IN} \leq 30V$		0.1	0.5	%
Load Regulation	$REG_{(LOAD)}$	$100\mu A \leq I_L \leq 150mA$		0.1	0.4	%
Dropout Voltage	V_D	$I_L = 100\mu A$		80	150	mV
		$I_L = 150mA$		380	600	
Ground Current	I_{GND}	$I_L = 100\mu A$		120	160	μA
		$I_L = 150mA$		8	14	mA
Dropout Ground Current	$I_{GND(D)}$	$V_{IN} = 4.5V$, $I_L = 100\mu A$		110	250	μA
Current Limit	I_{CL}	$V_{OUT} = 0$		200	250	mA
Reference Voltage	V_{REF}	$V_{REF} \leq V_{OUT} \leq (V_{IN} - 1V)$, $T_J = 25^\circ C$, $100\mu A \leq I_L \leq 100mA$	1.22	1.235	1.25	V
Feedback Bias Current	I_{FB}			20	60	nA
Error Comparator						
Output High Leakage Current		$V_{OH} = 30V$			2	μA
Output Low Voltage		$V_{IN} = 4.5V$, $I_{OL} = 400\mu A$		150	400	mV
Threshold Voltage		Upper	25	60		mV
		Lower		75	140	
Hysteresis				15		mV
Shutdown Input						
Input Logic Voltage	V_{SD}	Low			0.6	V
		High	2.0			V
Input Current	I_{SD}	$V_{SHUTDOWN} = 2.4V$			100	μA
		$V_{SHUTDOWN} = 30V$			750	
Regulator Shutdown Output Current	$I_{O(SD)}$	$V_{SHUTDOWN} \geq 2V$, $V_{IN} \leq 30V$, $V_{OUT} = 0$, Feedback pin to Tap 5V			20	μA

NOTES:

(1) Temperature coefficient is defined as the worst case voltage change divided by total temperature range.

March 17, 1998

PRINCIPLES OF OPERATION (LP2951 AND LP2951A)

Setting the Output Voltage

The LP2951(A) can be set to deliver any output voltage from 1.24V to 30V by using an external voltage divider. In addition, an internal voltage divider is provided if a 5V output is desired. To use the internal voltage divider, simply connect the sense pin to the output and the tap pin to the feedback pin (see block diagram). When using an external divider the sense and tap pins are left open, and the divider is installed from the output to ground, with its center connected to the feedback pin (see Adjustable Regulator figure below). When using an external voltage divider, resistances can be calculated from the following formula:

$$V_{OUT} = \left[\left(\frac{1.235}{R2} + 20 \times 10^{-9} \right) \times R1 \right] + 1.235 \text{ V}$$

An upper limit of values for R2 occurs at ~1.2MΩ if the regulator is to be operated when completely unloaded, as this allows the feedback divider to provide the 1μA minimum load recommended for the LP2951(A). If the regulator always has a load of 1μA or more connected externally, higher resistor values can be used, but attention must be paid to the -20nA (typical) bias current required by the feedback pin. Using a 1.2MΩ resistor for R2, this bias current will already cause a 2% shift in output voltage between full load and no load. Larger values of R2 exacerbate the problem. Using a 120KΩ resistor for R2 reduces the error caused by feedback bias current to 0.2% while still only requiring 10μA to feed the divider string.

Output Filtering

An output filter capacitor is always necessary with the LP2951(A) in order to assure output stability. The size of this capacitor varies with output voltage (smaller at higher output voltages) and output current (smaller at lower output currents). For 5V operation 1μF is sufficient. For regulator operation at a minimum output voltage, (1.24V) and output currents of 100mA, the required filter increases to 3.3μF. Any type of capacitor may be used, although if aluminum electrolytics are chosen, the equivalent series resistance (ESR) should be held to 5Ω or less. For small load currents the capacitance can be reduced. 0.33μF will be satisfactory for output currents of 10mA or less, and 0.1μF will work if output current is below 1mA.

Theoretically, it is also possible for the regulator to become unstable if very large capacitances (>10,000μF)

are connected to the output, but this has not been observed in practice. It is also important that the capacitance be mounted close (1cm or less) to the output pin of the regulator.

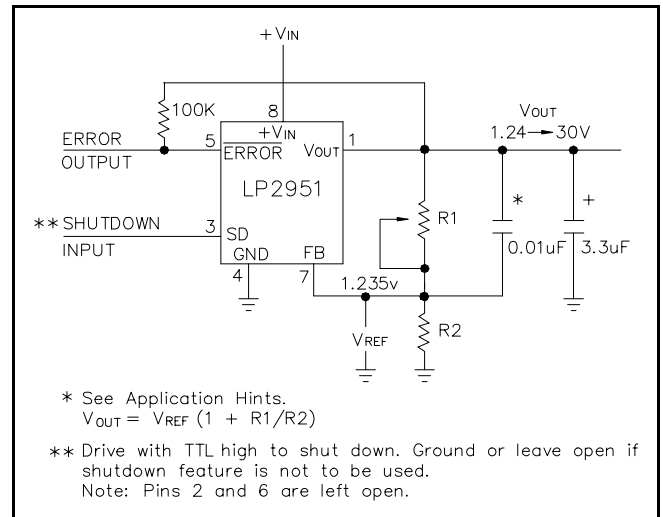

Adjustable Regulator

If the lead inductance between the input of the LP2951(A) and its power source exceeds ~500nH (approximately 10"/25cm of 0.031"/0.78mm trace) it may also be necessary to add a filter capacitor between the input terminal and ground. A 1μF tantalum or aluminum capacitor is usually sufficient. Lower values can be used if load currents are small. Noise injection into the feedback terminal of the LP2951(A) from nearby noise sources can also upset the output. Generally this can be cured by the addition of 100pF or so from the feedback terminal to the output.



March 17, 1998

PRINCIPLES OF OPERATION (LP2951 and LP2951A) (cont.)

Reducing Output Noise

In ultra-quiet systems, or when the LP2951(A) is being used as a reference, it may be desirable to perform additional output filtering to reduce noise. While this can be done simply using larger capacitors on the output, that solution tends to be bulky and expensive, and eventually, with huge capacitors (>1,000µF) may cause instability in the regulator. Generally, it is more cost-effective to let the regulator regulate output noise away. This can be done by bypassing the upper resistor in the feedback divider with a small capacitor to provide a more direct path for AC feedback. The size of this capacitor can be calculated from the formula:

$$C_{\text{BYPASS}} = \frac{1}{2\pi R_1 f_{\text{corner}}}$$

where R1 is the upper resistor of the feedback divider and f_{corner} is the frequency above which the increased AC feedback is to become active. Because the gain of the error amplifier in the LP2951(A) begins to roll off at about 300 Hz, this is generally an optimum choice for corner frequency.

The reduction of the output noise will be proportional to the ratio of the two resistors in the feedback divider,

$$\frac{R1}{R1 + R2}$$

and will increase 20 dB per decade at frequencies above the corner frequency chosen, up to the frequency where the error amplifier's gain has rolled off to 1 (≈100KHz). In order to maintain regulator stability when using a noise-reducing bypass capacitor, it will also be necessary to increase the size of the output filter capacitor by the ratio

$$\frac{R1}{R1 + R2}$$

March 17, 1998

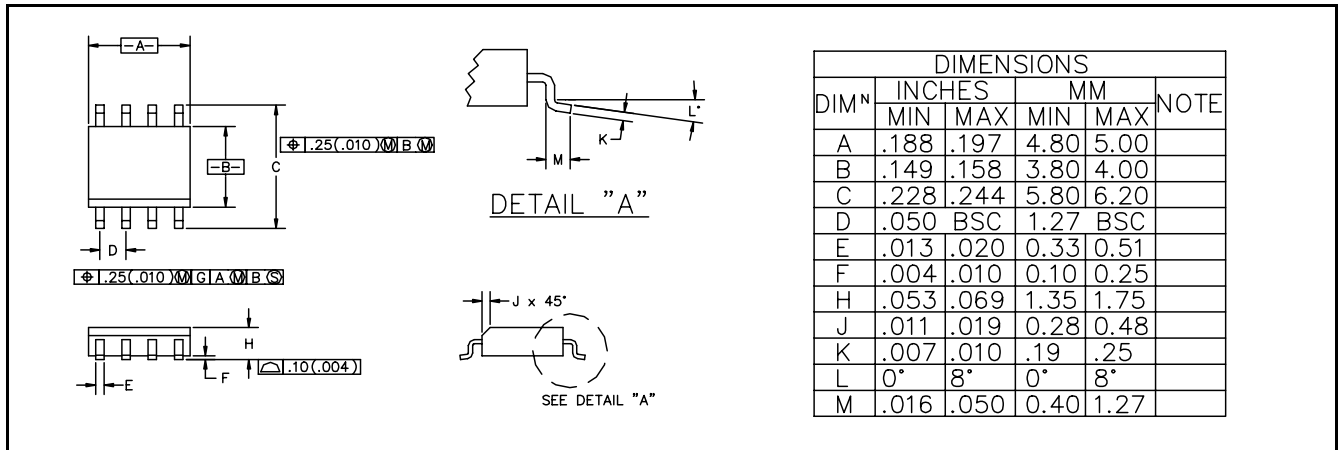
OUTLINE DRAWING SO-8

LAND PATTERN SO-8
