

PRELIMINARY - November 3, 1997

TEL:805-498-2111 FAX:805-498-3804 WEB:<http://www.semtech.com>

DESCRIPTION

The MP60G series of power modules are highly efficient synchronous switching DC/DC converters with an integral connector conforming to Intel Corporation's Voltage Regulator Module specification (VRM 8.1 DC-DC Converter Specification). The modules have additional monitoring functions for Power Good Signal, Output Enable and optional Over Voltage Protection.

A five bit voltage identification code (VID) programs the output voltage between 1.8V and 3.5V to support existing and future versions of the Pentium® II processor. The MP60G is available in several options to provide superior cost/performance tradeoff. The MP60G-5N, -5P and -NH modules convert 5V to the programmed VID output. The N designation signifies no Over Voltage Protection (OVP) while the P represents OVP. The NH module does not provide OVP and does not have heat sinks.

The MP60G-12XX modules are intended for 12V server applications. Again, the N and P designations denote the OVP option. The MP60G-12A will work from either 5V or 12V input on the 5Vin pins (Pins 1A, 2A, 3A, 1B and 2B).

MODULE DIAGRAM

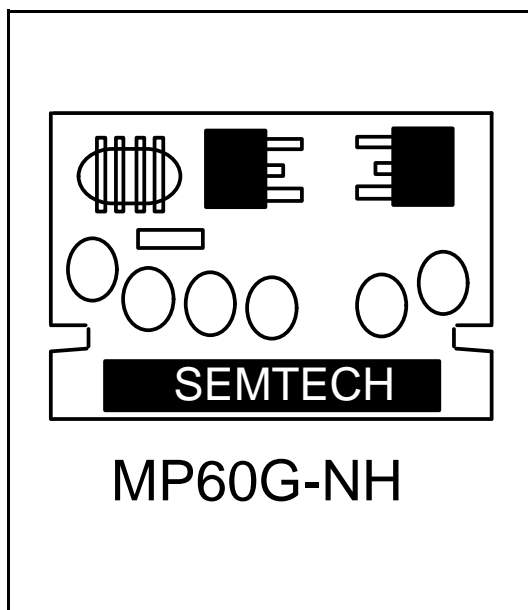

FEATURES

- Integral 40-pin header connector
- Programmable output voltage to suit processor (by VID code); adjustable from 1.8 to 3.5V
- Maximum output current 16A
- Efficiency >85% at full load
- Fast transient response

APPLICATIONS

- Intel Pentium® II Power Supply
- Deschutes Power Supply
- Deschutes Memory Power Supply

ORDERING INFORMATION

DEVICE	V _{CONTROL}	V _{IN}	OVP
MP60G-5N	12V	5V	No
MP60G-5P	12V	5V	Yes
MP60G-12N	12V	12V	No
MP60G-12P	12V	12V	Yes
MP60G-12AN	12V	12 or 5V	No
MP60G-12AP	12V	12 or 5V	Yes
MP60G-NH	12V	5V	No

SIMPLIFIED BLOCK DIAGRAM

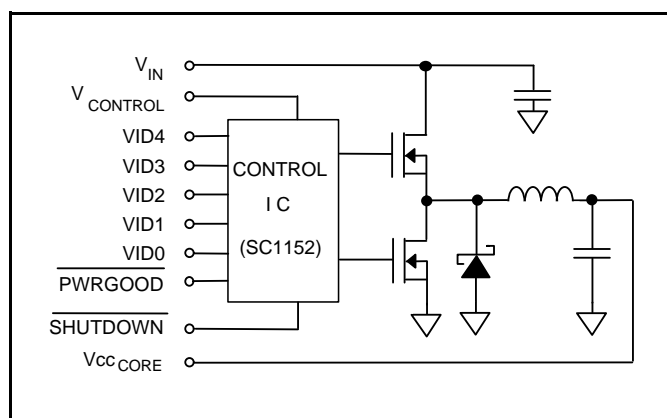

PRELIMINARY - November 3, 1997

ELECTRICAL CHARACTERISTICS

Conditions: $V_O = VID$, $V_{IN} = 4.75 - 12.6V$, $I_O = 10A$, unless otherwise stated.

PARAMETER	SYMBOL	MIN	TYP	MAX	UNITS
Output Voltage	V_O	$0.95IV_{OI}$	V_O	$1.05IV_{OI}$	V
Output Current MP60G-NH, 5X	I_O	0.3		15	A
Output Current MP60G-12X, 12AX	I_O	0.3		15	A
Current Surge Limit MP60G-NH, 5X	I_S	15.5			A
Current Surge Limit MP60G-12X, 12AX	I_S	15.5			A
Output Over Voltage Protection	OVP	Setpoint + 20%			V
Output Slew Rate		30			A/ μ s
Quiescent Current	I_Q		15		mA
Temperature Coefficient	T_C		TBD		%/ $^{\circ}$ C
Temperature Stability	T_S		TBD		%
Operating Efficiency (full load)	η		85		%
Switching Frequency	f_{SW}		200		kHz
DC Output Ripple Voltage				50	mV _{p-p}
Operating Temperature Range	T_J	0		70	$^{\circ}$ C

VOLTAGE IDENTIFICATION CODE					
Input Pins					$V_{CC_{CORE}}$
VID4	VID3	VID2	VID1	VID0	(VDC)
0	0	1	0	1	1.80
0	0	1	0	0	1.85
0	0	0	1	1	1.90
0	0	0	1	0	1.95
0	0	0	0	1	2.00
0	0	0	0	0	2.05
1	1	1	1	1	2.0
1	1	1	1	0	2.1
1	1	1	0	1	2.2
1	1	1	0	0	2.3
1	1	0	1	1	2.4
1	1	0	1	0	2.5
1	1	0	0	1	2.6
1	1	0	0	0	2.7
1	0	1	1	1	2.8
1	0	1	1	0	2.9
1	0	1	0	1	3.0
1	0	1	0	0	3.1
1	0	0	1	1	3.2
1	0	0	1	0	3.3
1	0	0	0	1	3.4
1	0	0	0	0	3.5

0 = processor pin connected to V_{SS} , 1 = open

PRELIMINARY - November 3, 1997

INPUT AND OUTPUT CONNECTIONS			
Pin No.	Row A	Row B	Pin No.
1	5V in	5V in	1
2	5V in	5V in	2
3	5V in	Reserved	3
4	12V in	12V in	4
5	Reserved	Reserved	5
6	Reserved	OUTEN	6
7	VID0	VID1	7
8	VID2	VID3	8
9	VID4	PWRGD	9
10	V _{CC} CORE	V _{SS}	10
11	V _{SS}	V _{CC} CORE	11
12	V _{CC} CORE	V _{SS}	12
13	V _{SS}	V _{CC} CORE	13
14	V _{CC} CORE	V _{SS}	14
15	V _{SS}	V _{CC} CORE	15
16	V _{CC} CORE	V _{SS}	16
17	V _{SS}	V _{CC} CORE	17
18	V _{CC} CORE	V _{SS}	18
19	V _{SS}	V _{CC} CORE	19
20	V _{CC} CORE	V _{SS}	20

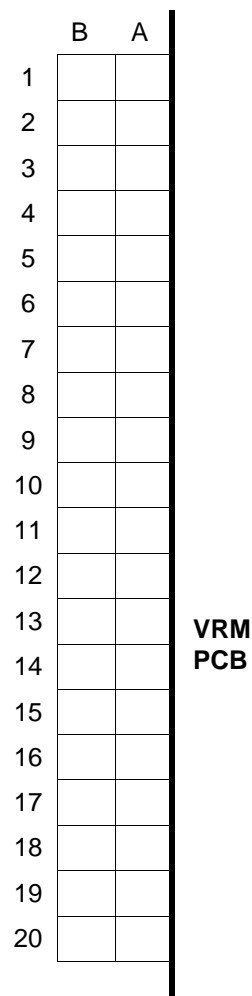

End view of VRM connector
(viewed from motherboard side)

VOLTAGE REGULATOR MODULE CONNECTOR PIN REFERENCE

Pin Name	Pin Function
PWRGD	Power Good: When the output voltage is not within specifications (nominal or selected voltage $\pm 7\%$) this signal will be in the low state. The PWRGD signal will change to the proper state within 5ms of the output coming into or going out of specification.
OUTEN	Output Enable: A low state disables the output voltage. When disabled, the PWRGD signal shall be in the low state.
V _{CC} CORE	Microprocessor core voltage programmed with VID inputs
V _{SS}	System Ground
VID[0:4]	Voltage Identification: The module will accept five open collector signals, used to indicate the voltage required by the processor, as defined by Intel
5V in	Main power input for regulation.
12V in	Must also be connected (input for control circuits only)

PRELIMINARY - November 3, 1997

MECHANICAL DIMENSIONS

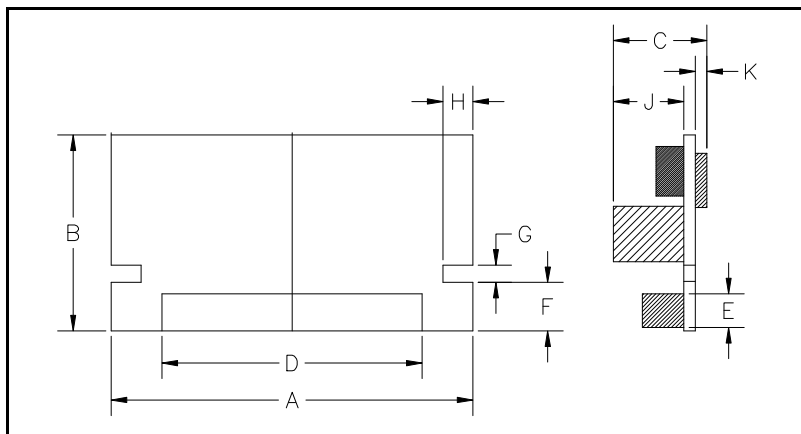

Component size and location for illustration only

Dimension	mm	inch	
A	79.7	3.14	Max
B	38.1	1.50	Max
C	24.4	0.96	Max
D	57.4	2.26	Typ
E	8.13	0.32	Typ
F	10.67 ± 0.13	0.42 ± 0.005	Typ
G	3.81	0.15	Typ
H	6.50	0.26	Min
J	21.6	0.85	Max
K	3.6	0.14	Max