

POWER MANAGEMENT

Description

The LM2575/6 series switching regulators are monolithic integrated circuits designed for use in “buck” or “buck/boost” regulator applications requiring accurate output voltages over combined variations of line, load and temperature. This unique series greatly simplifies switching power supply design. The LM2575 has a maximum output current of 1A and the LM2576 is rated for 3A.

The LM2575/6 series miniconverters include a switching regulator and compensation network all within the same package. Just add a choke, catch diode and two capacitors to obtain an efficient DC-to-DC converter. The current limit and thermal shutdown features of the LM2575/6 series fully protect the device against overstress conditions.

The LM2575/6 series offers an alternative to popular 3 terminal linear regulators by providing higher efficiency with reduced heatsink size. In many applications a heat sink will not be required.

Features

- ◆ Pin for pin replacement for National's LM2575/6 series
- ◆ DC-to-DC buck or buck/boost converter requiring only 4 support components
- ◆ Fixed or adjustable voltages
- ◆ Preset output voltages of 3.3V, 5V and 12V
- ◆ Wide output voltage range, 1.23V to 35V
- ◆ 82% typical efficiency @ 5V out
- ◆ Wide input voltage range, 4V to 40V
- ◆ Inhibit/enable control pin
- ◆ Industrial temperature range
- ◆ TO-220 and TO-263 packages

Applications

- ◆ Micro controller power supplies
- ◆ Medical equipment
- ◆ Industrial power supplies
- ◆ Instrumentation power supplies

Typical Application Circuits

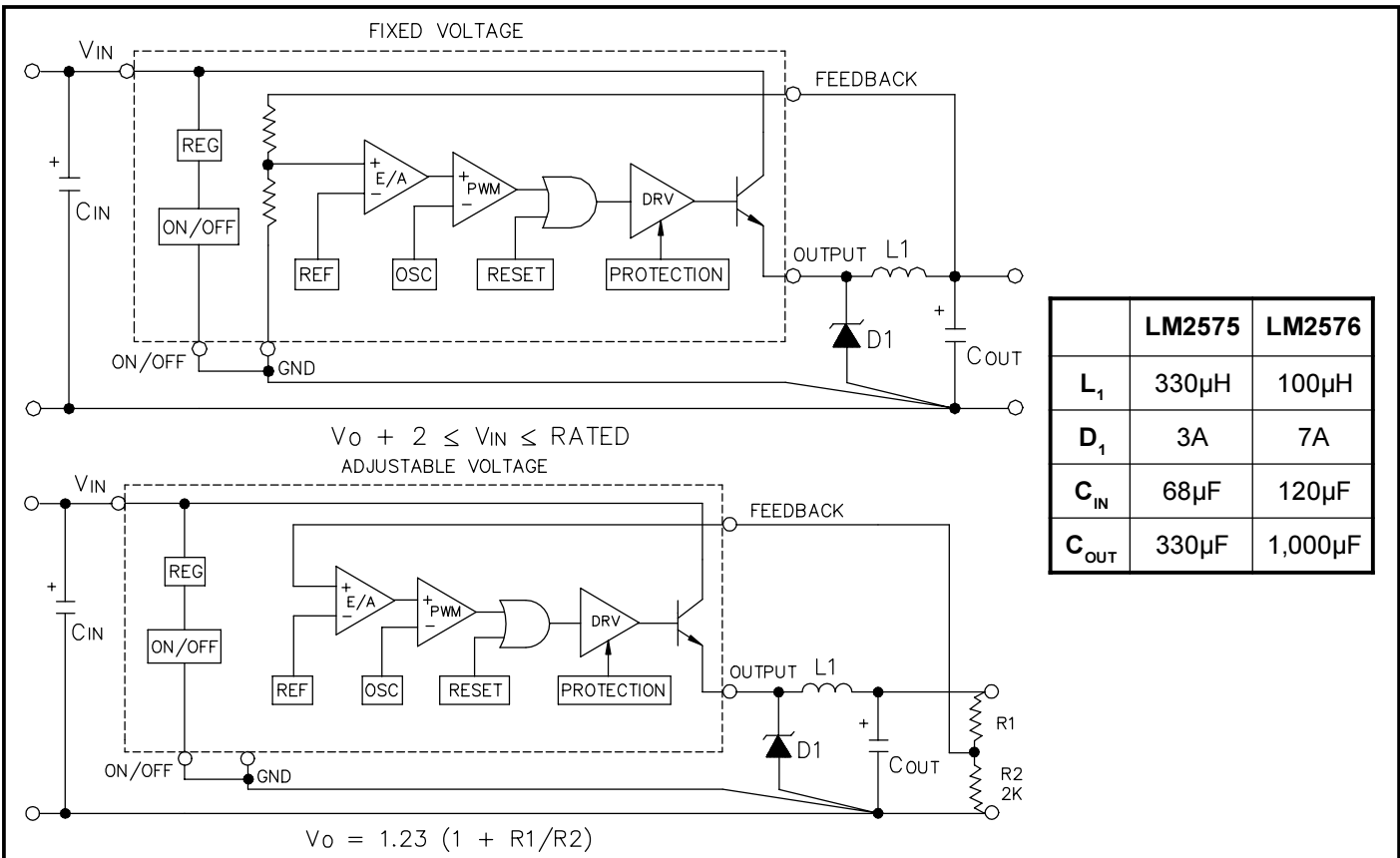

POWER MANAGEMENT

Absolute Maximum Ratings

Parameter	Symbol	Maximum	Units
Input Voltage	V_{IN}	45	V
On/Off Pin Input Voltage	$V_{ON/OFF}$	$-0.3 \leq V_{ON/OFF} \leq V_{IN}$	V
Output Voltage to Common (Steady State)		-1	V
Power Dissipation	P_D	Internally Limited	W
Thermal Resistance Junction to Ambient TO-220 TO-263	θ_{JA}	55 60	$^{\circ}C/W$
Thermal Resistance Junction to Case TO-220 TO-263	θ_{JC}	2.0 2.0	$^{\circ}C/W$
Operating Junction Temperature Range	T_J	-40 to +125	$^{\circ}C$
Storage Temperature Range	T_{STG}	-65 to +150	$^{\circ}C$
Lead Temperature (Soldering) 10 Sec.	T_{LEAD}	300	$^{\circ}C$
ESD Rating (Human Body Model)	V_{ESD}	2	kV

Electrical Characteristics

Unless otherwise specified: $V_{IN} = 12V$ for 3.3V, 5V and ADJ options and 25V for 12V option; $V_{OUT} = 5V$ for ADJ option; $T_A = 25^{\circ}C$; V_{IN} rated = 40V; $I_o = 0.5$ to 3A (LM2576), 0.2 to 1A (LM2575). Values in **bold** apply over full operating temperature range.

Parameter	Symbol	Test Conditions	Min	Typ	Max	Units
Output Voltage LM2576-3.3	V_o	$I_o = 0.5A$	3.23	3.30	3.37	V
		8V to V_{IN} Rated	3.20		3.40	
			3.14		3.47	
Output Voltage LM2576-5	V_o	$I_o = 0.5A$	4.90	5.00	5.10	V
		8V to V_{IN} Rated	4.85		5.15	
			4.75		5.25	
Output Voltage LM2576-12	V_o	$I_o = 0.5A$	11.76	12.00	12.24	V
		15V to V_{IN} Rated	11.52		12.48	
			11.40		12.60	
Feedback Voltage LM2576-ADJ, $V_o = 5V$	V_{FB}	$I_o = 0.5A$	1.217	1.230	1.243	V
		8V to V_{IN} Rated	1.193		1.267	
			1.180		1.280	
Feedback Bias Current LM2576-ADJ	I_B	$V_{IN} = 12V, I_o = 0.5A$		50	100	nA
					500	

POWER MANAGEMENT
Electrical Characteristics (Cont.)

Unless otherwise specified: $V_{IN} = 12V$ for 3.3V, 5V and ADJ options and 25V for 12V option; $V_{OUT} = 5V$ for ADJ option; $T_A = 25^\circ C$; V_{IN} rated = 40V; $I_O = 0.5$ to 3A (LM2576), 0.2 to 1A (LM2575). Values in **bold** apply over full operating temperature range.

Parameter	Symbol	Test Conditions	Min	Typ	Max	Units
Output Voltage LM2575-3.3	V_O	$I_O = 0.2A$	3.23	3.30	3.37	V
		8V to V_{IN} Rated	3.20		3.40	
			3.14		3.47	
Output Voltage LM2575-5	V_O	$I_O = 0.2A$	4.90	5.00	5.10	V
		8V to V_{IN} Rated	4.85		5.15	
			4.75		5.25	
Output Voltage LM2575-12	V_O	$I_O = 0.2A$	11.76	12.00	12.24	V
		15V to V_{IN} Rated	11.52		12.48	
			11.40		12.60	
Feedback Voltage LM2575-ADJ, $V_O = 5V$	V_{FB}	$I_O = 0.2A$	1.217	1.230	1.243	V
		8V to V_{IN} Rated	1.193		1.267	
			1.180		1.280	
Feedback Bias Current LM2575-ADJ	I_B	$V_{IN} = 12V, I_O = 0.2A$		50	100	nA
					500	
Efficiency/Option 3.3V 5V 12V ADJ, $V_O = 5V$	η	$V_{IN} = 12V, I_O = 1A$ (LM2575, 3A for LM2576)		77		%
				82		
		$V_{IN} = 15V, I_O = 1A$ (LM2575, 3A for LM2576)		88		
			$V_{IN} = 12V, I_O = 1A$ (LM2575, 3A for LM2576)		82	
Switching Frequency	f_{SX}		47	52	58	kHz
			43		62	
Saturation Voltage ⁽¹⁾	V_{SAT}	LM2575, $I_O = 1A$		0.9	1.2	V
		LM2576, $I_O = 3A$		0.9	1.4	
Max. Duty Cycle (On) ⁽³⁾	DC		93	98		%
Peak Current LM2575 ⁽¹⁾	I_{CL}		1.7	2.2	3.0	A
			1.3		3.2	
Peak Current LM2576 ⁽¹⁾	I_{CL}		4.2	5.8	6.9	A
			3.5		7.5	

POWER MANAGEMENT
Electrical Characteristics (Cont.)

Unless otherwise specified: $V_{IN} = 12V$ for 3.3V, 5V and ADJ options and 25V for 12V option; $V_{OUT} = 5V$ for ADJ option; $T_A = 25^\circ C$; V_{IN} rated = 40V; $I_o = 0.5$ to 3A (LM2576), 0.2 to 1A (LM2575). Values in **bold** apply over full operating temperature range.

Parameter	Symbol	Test Conditions	Min	Typ	Max	Units
Output Leakage Current ⁽²⁾	I_L	$V_{IN} = V_{IN}$ Rated			2	mA
Output = 0V				7.5	30	
Output = -1V						
Quiescent Current ⁽²⁾	I_Q			5	10	mA
Standby Quiescent Current (On/Off Pin = 5V)	I_{STBY}			50		μA
On/Off Pin Logic Input Level	V_{IH}		2.2	1.4		V
			2.4			
	V_{IL}			1.2	1.0	V
On/Off Pin Input Current	I_{IH}	$V_{ON/OFF} = 5V$ (Off)		12	30	μA
	I_{IL}	$V_{ON/OFF} = 0V$ (On)		0	10	

Notes:

- (1) Output sourcing current, resistive load, no inductor or capacitor.
- (2) Feedback = $V_o + 1.0V$.
- (3) Feedback = 0V.

POWER MANAGEMENT

Pin Configurations

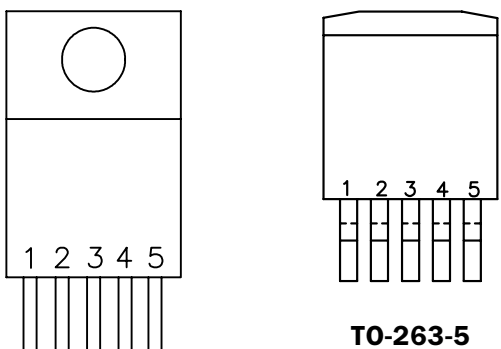

LM2575, LM2576	
Pin	Function
1	V_{IN}
2	OUTPUT
3	COMMON
4	FEEDBACK
5	ON/OFF
TAB is COMMON	

Ordering Information

Device ⁽¹⁾	Package	Current
LM2575T-XX	TO-220-5 ⁽²⁾⁽³⁾	1A
LM2575S-XX.TR	TO-263-5 ⁽⁴⁾	
LM2576T-XX	TO-220-5 ⁽²⁾⁽³⁾	3A
LM2576S-XX.TR	TO-263-5 ⁽⁴⁾	

Notes:

(1) -XX = Voltage Option. Available voltages are 3.3V (-3.3), 5V (-5.0), 12V (-12), and ADJ (-ADJ), which is adjustable between 1.23V and 35V.

(2) Lead bend options for TO-220-5 are: T-XX = Straight in-line; T-XX-V = Vertical Staggered; T-XX-H = Horizontal Staggered. Please refer to outline drawings at the end of this datasheet.

(3) Only available in tube packaging. A tube contains 50 devices.

(4) Only available in tape and reel packaging. A reel contains 800 devices.

Block Diagram

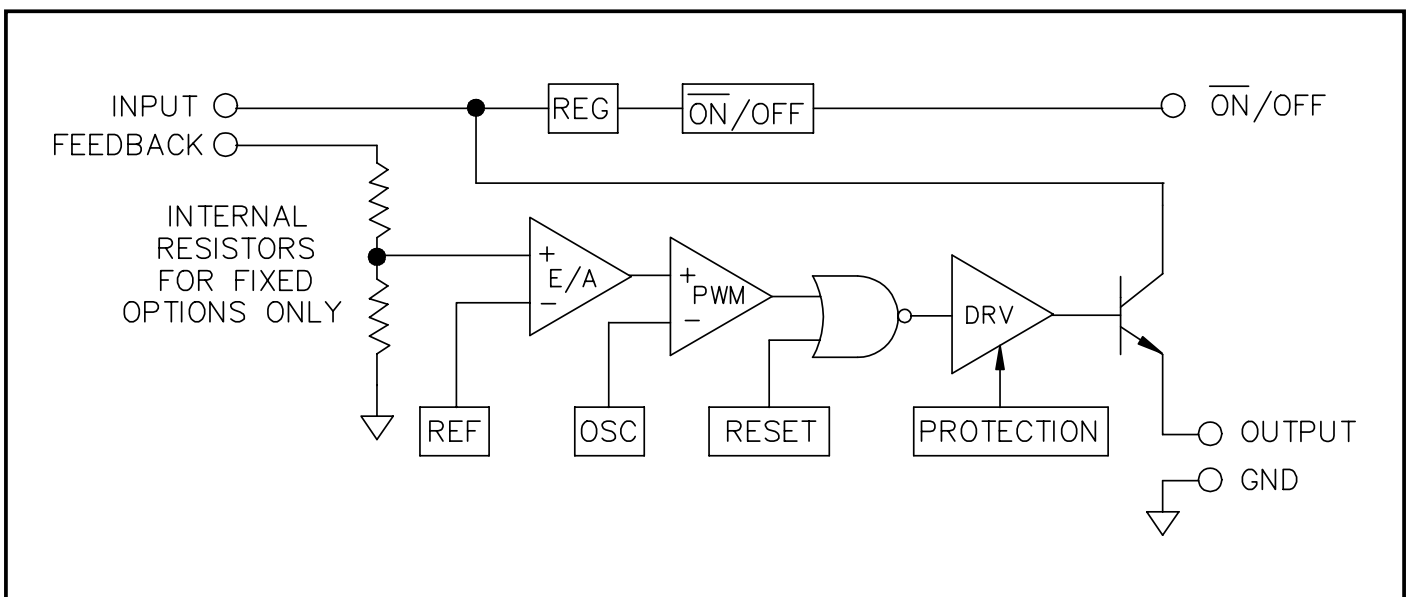

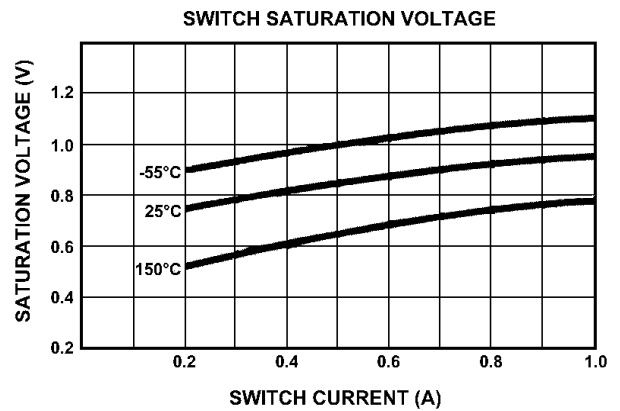
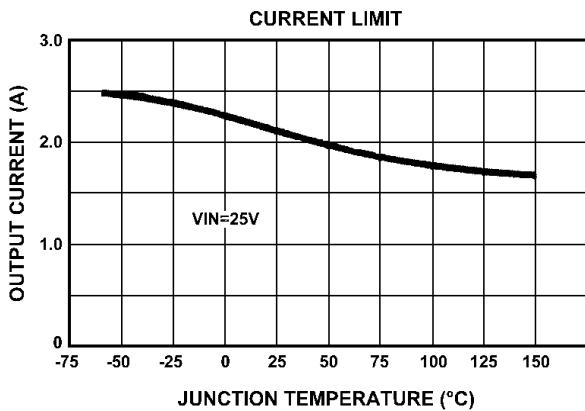
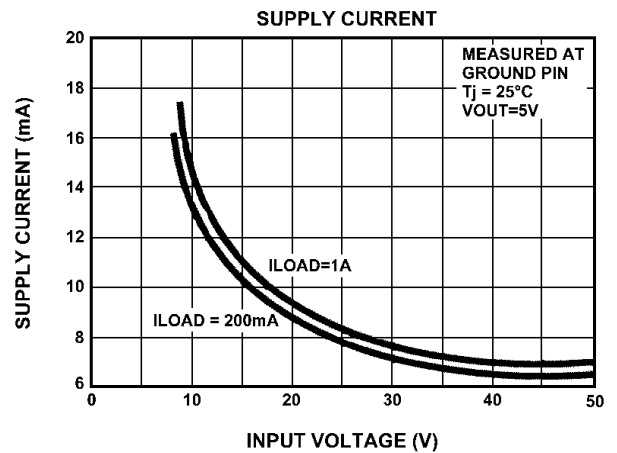
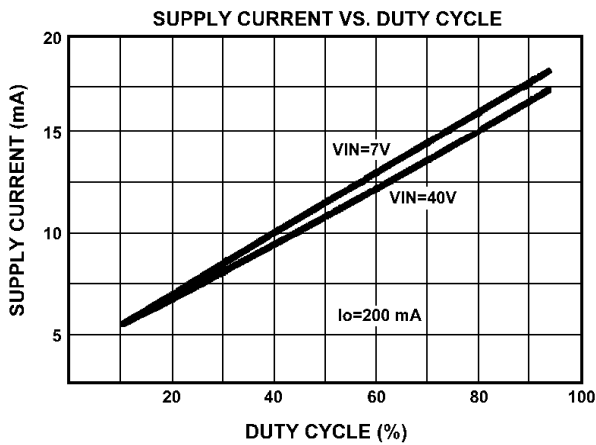
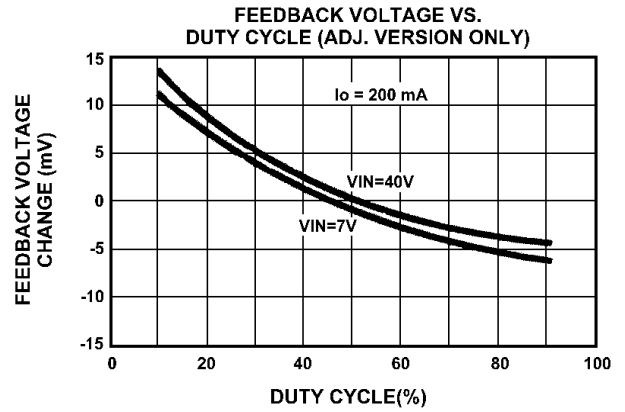
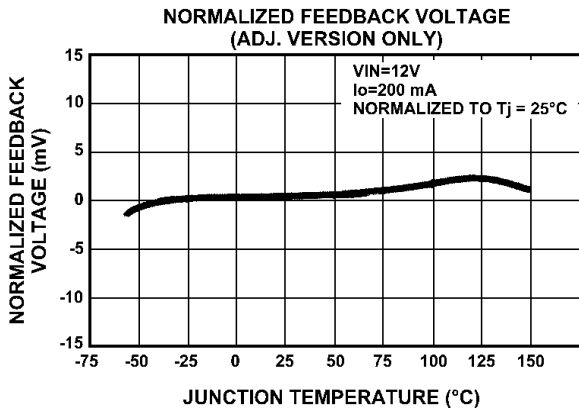
POWER MANAGEMENT
Typical Characteristics - LM2575

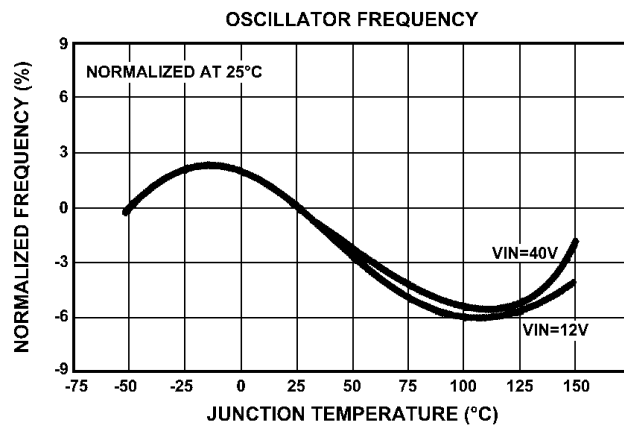
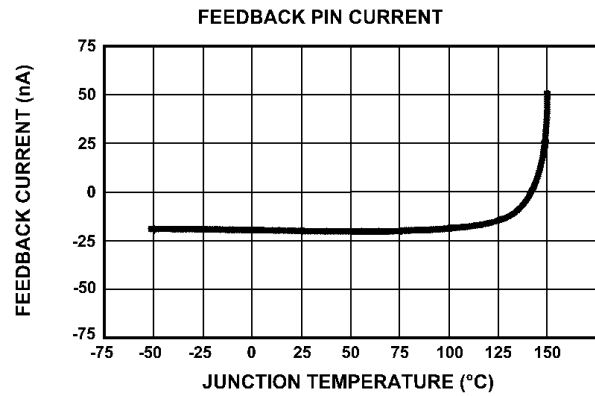
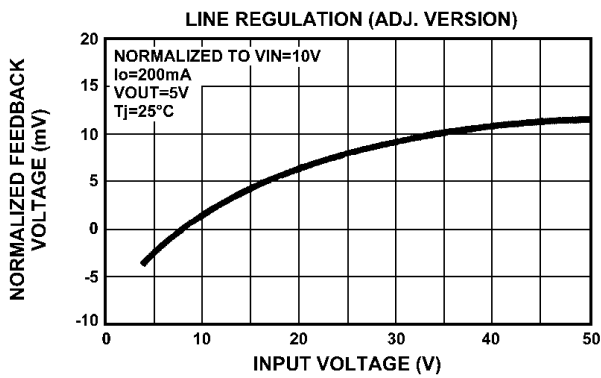
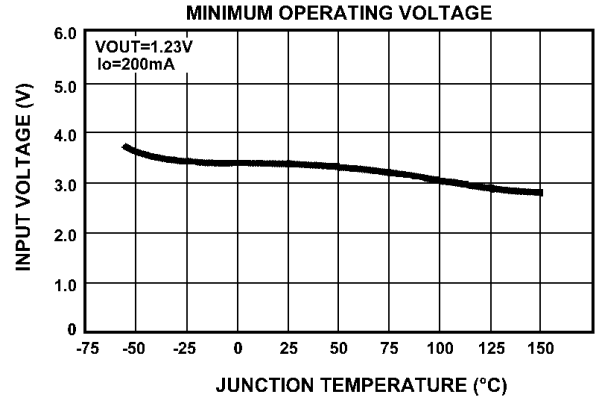
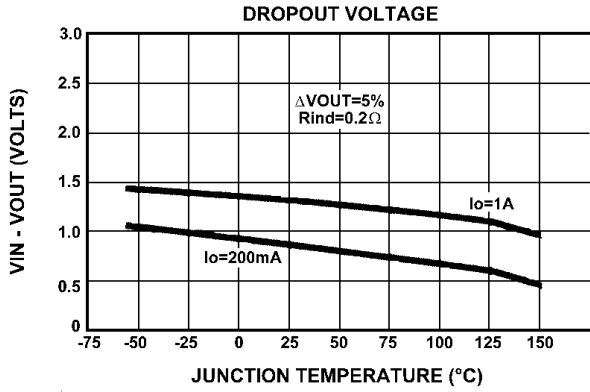
POWER MANAGEMENT
Typical Characteristics - LM2575 (Cont.)

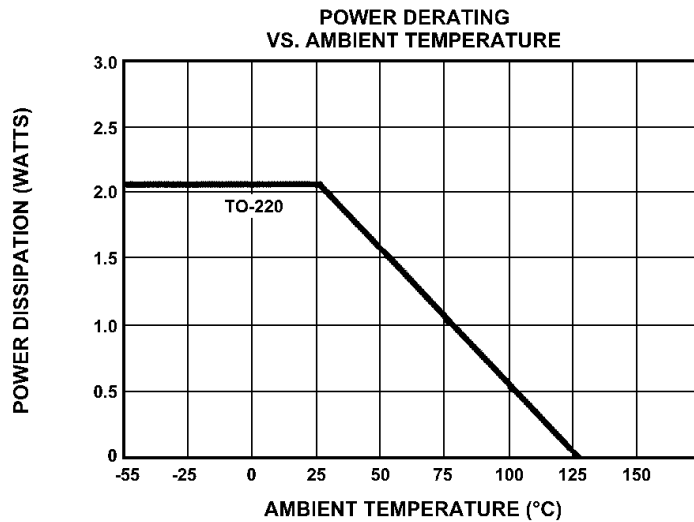
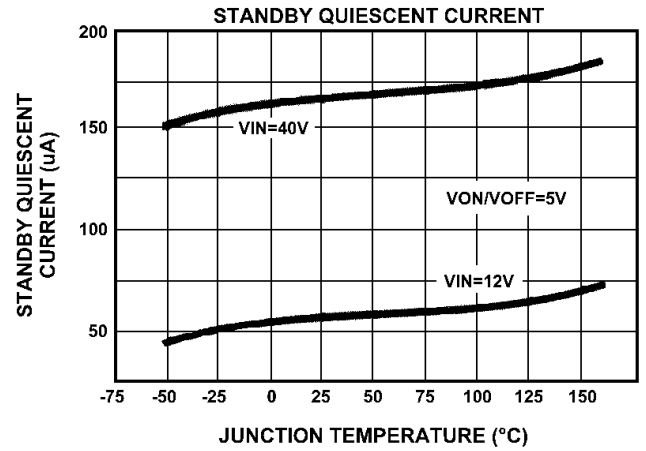
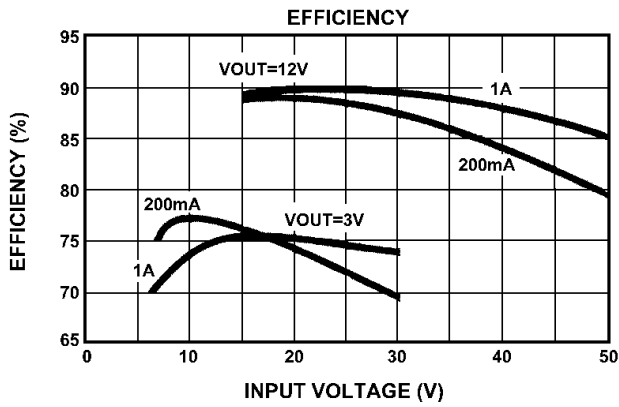
POWER MANAGEMENT
Typical Characteristics - LM2575 (Cont.)

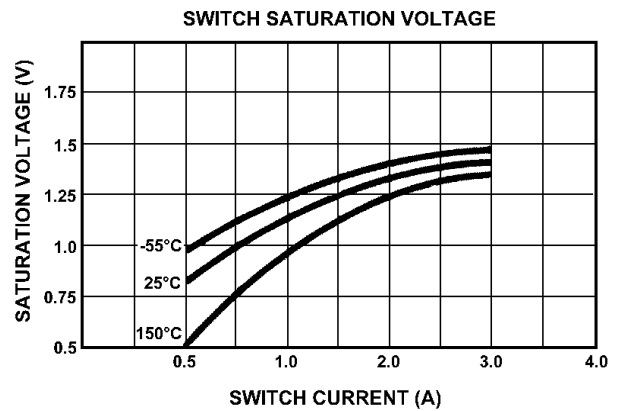
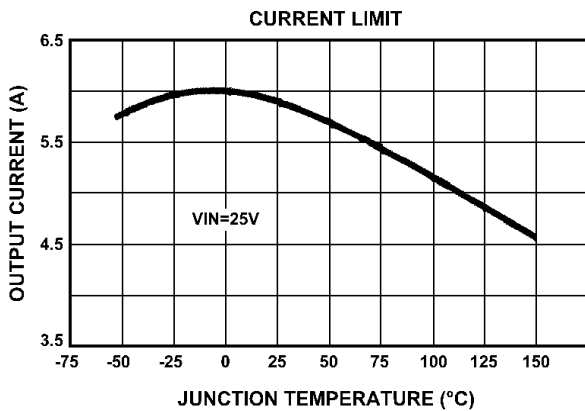
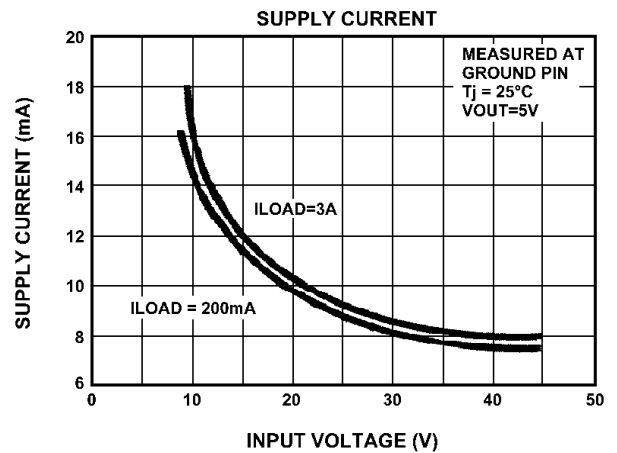
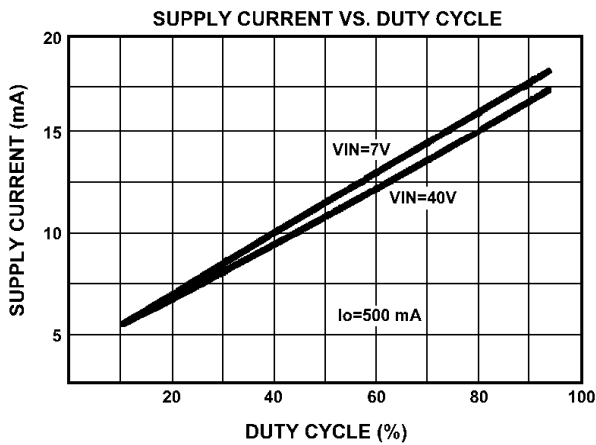
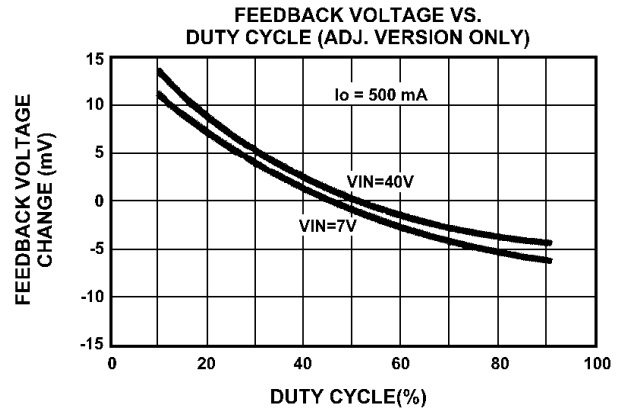
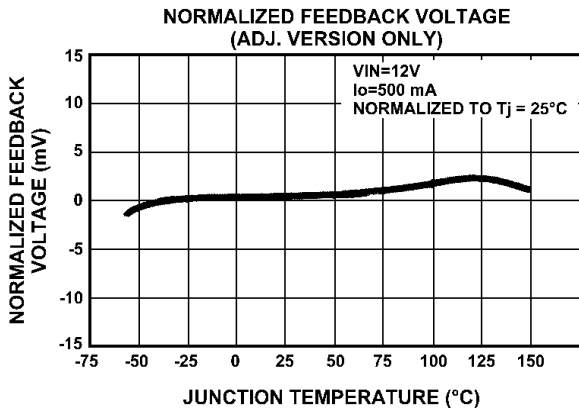
POWER MANAGEMENT
Typical Characteristics - LM2576

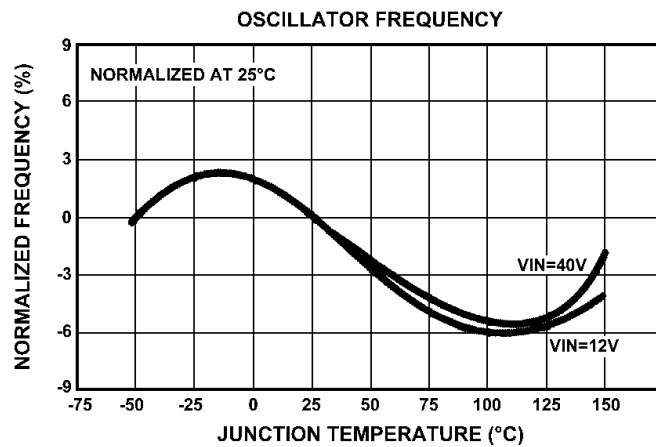
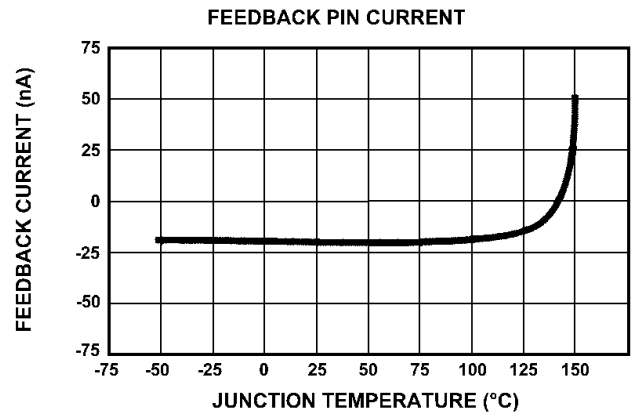
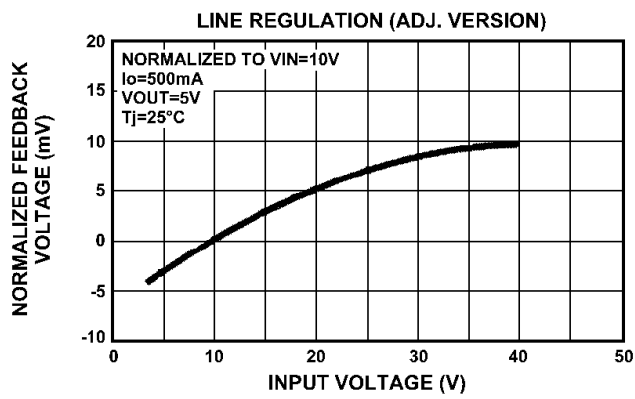
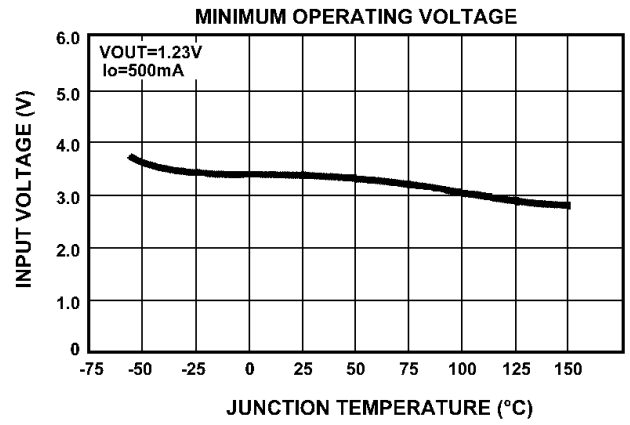
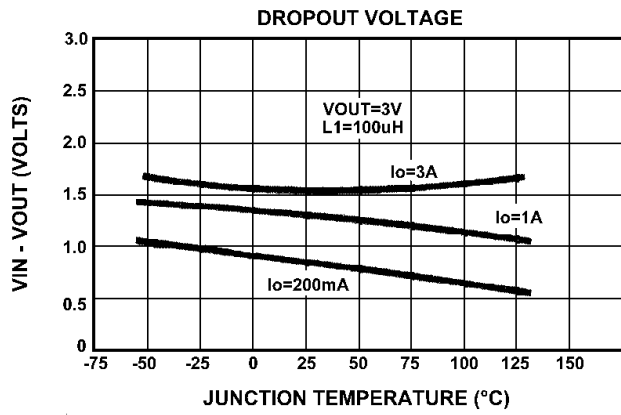
POWER MANAGEMENT
Typical Characteristics - LM2576 (Cont.)

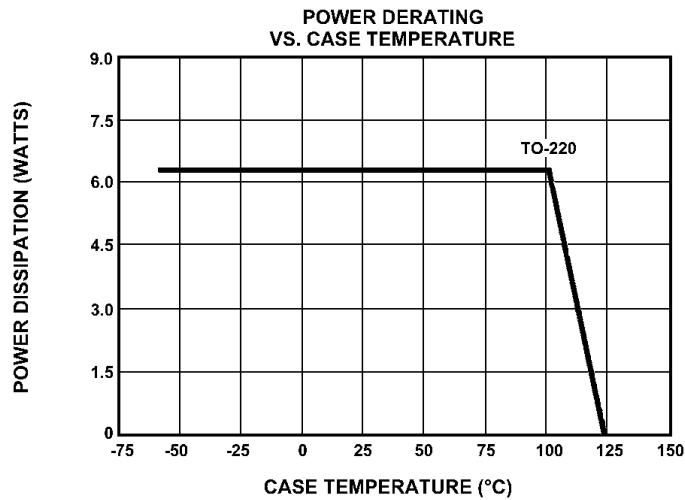
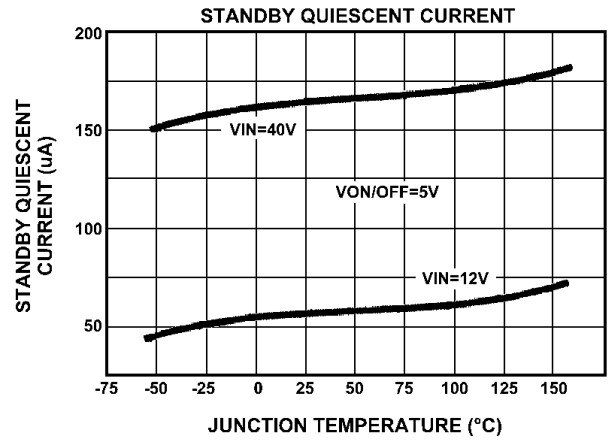
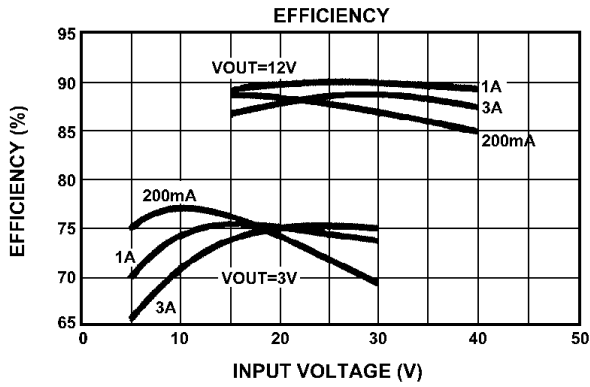
POWER MANAGEMENT
Typical Characteristics - LM2576 (Cont.)

POWER MANAGEMENT

Applications Information - Buck Mode

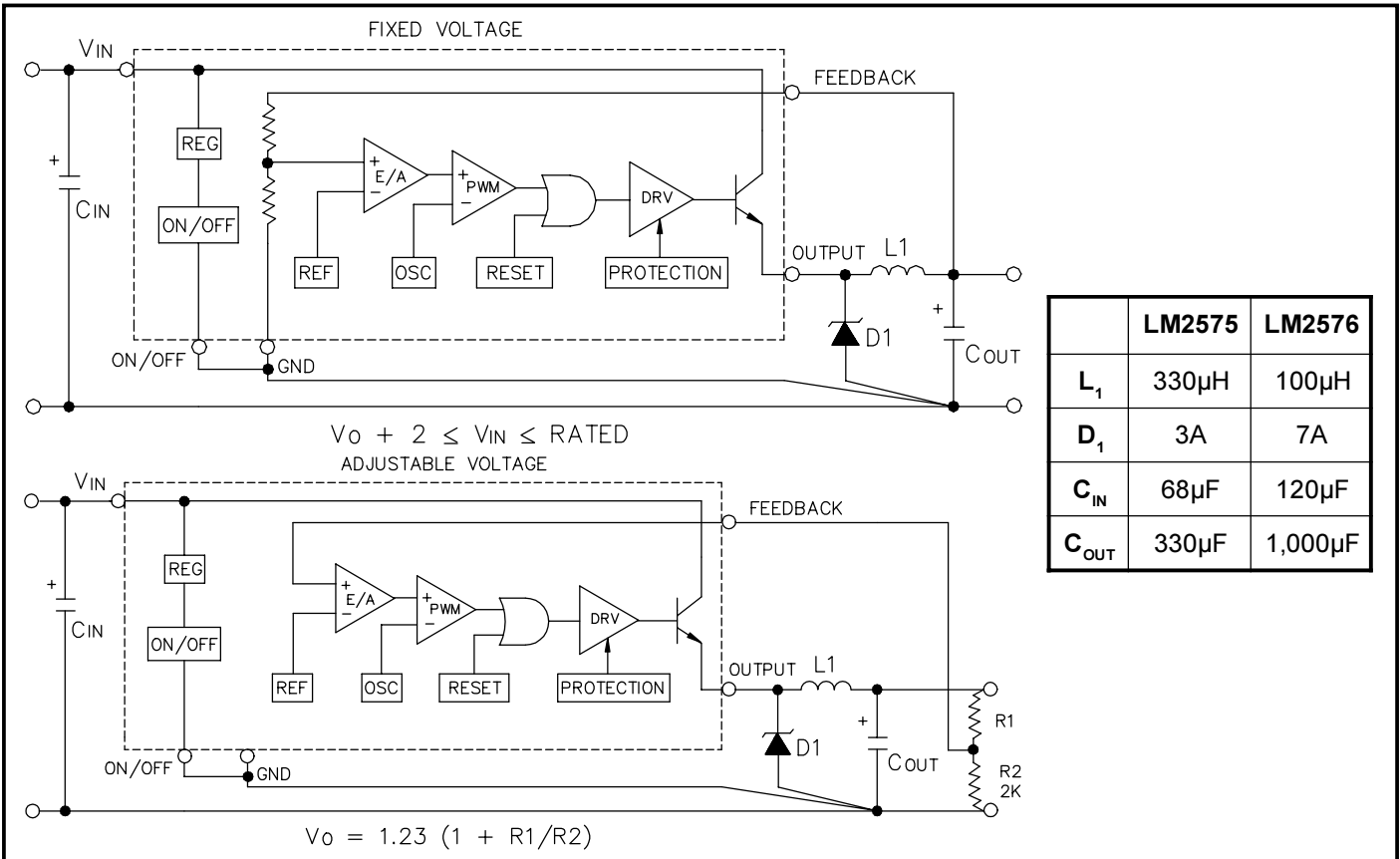

The above component selections will be adequate for most applications for output currents from 250mA to 3A (LM2576) or 150mA to 1A (LM2575). Applications with V_{OUT} below 5V or above 24V may require component adjustment for maximum performance; please contact factory for application assistance.

1. Device Selection. Select an appropriate device from the "Ordering Information" guide based upon voltage option and package.

2. Thermal Conditions. Most applications will not require a heatsink for the TO-220 package. Approximate power dissipation is:

$$P = \frac{V_O I_O V_{SAT}}{V_{IN}} + 0.02 V_{IN} \frac{|V_O|}{V_{IN}}$$

3. Catch Diode. If the output must be capable of a sustained short, the I_F rating must be above 3A for the LM2575 and 7A for the LM2576. The use of an ultra fast diode with soft recovery characteristics or a Schottky will be adequate. The major impact on the selection of a

Schottky versus an ultra fast diode is efficiency. Schottkys will provide approximately 4% to 5% improvement for V_{OUTS} below 12V, whereas above 12V the difference will become less significant. Breakdown rating must be in excess of V_{IN} for margin.

4. Input Capacitor. The value shown will be adequate for most applications. Ripple voltage at the switching frequency is caused by the input capacitor supplying load current during the on time of the power switch. The use of a low ESR switching type capacitor will minimize ripple to an acceptable level.

5. Layout. Use short connections with a central point ground to prevent improper operation caused by stray inductance and ground loops.

6. Output Capacitor. Ripple voltage on V_{OUT} is directly related to the value of C_{OUT} and the internal resistance ESR of C_{OUT} . Output noise can be lowered by increasing C_{OUT} or by selecting a capacitor with a lower ESR. ESR must be a minimum of 0.03 Ω for the LM2576 or 0.07 Ω for the LM2575 to maintain stability, otherwise raise the value of C_{OUT} .

POWER MANAGEMENT

Applications Information (Cont.)

7. Switching Spikes. Switching spikes will also occur due to distributive capacitance across turns of the inductor when combined with output capacitor series inductance (ESL). Reduction to a level at or below the switching ripple can be achieved by using a post filter as shown below.

Switching Spike Reduction

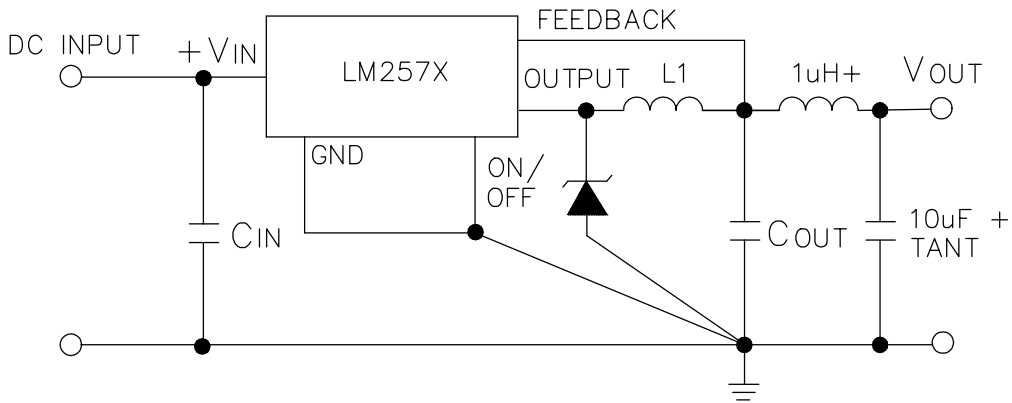

Typical Buck Shutdown

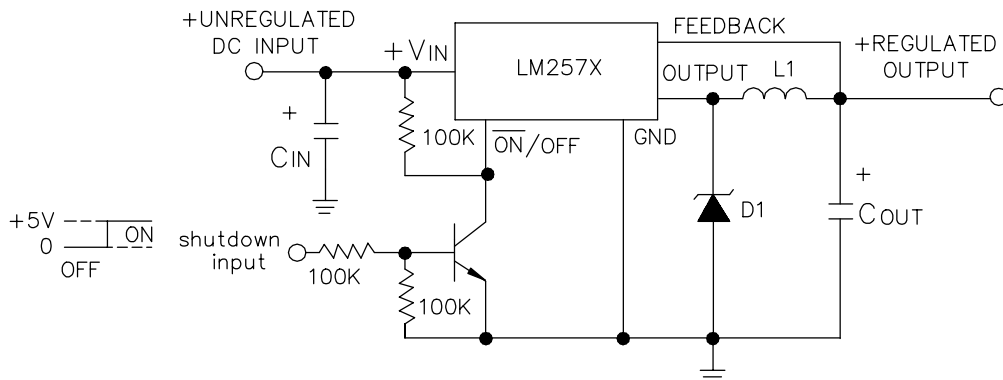
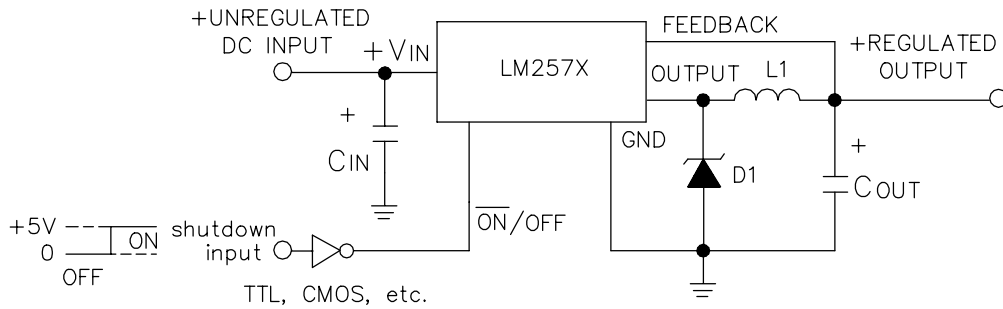

Turn-On Delay

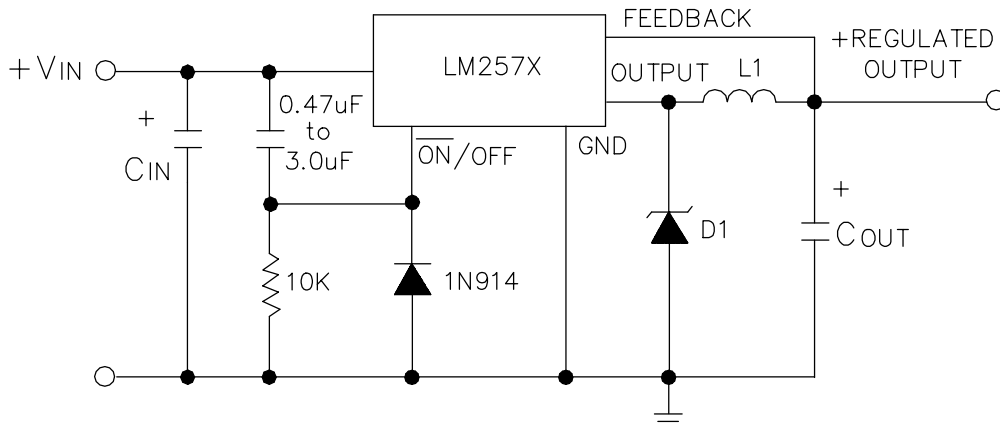

Circuit allows for C_{IN} to be fully charged before start-up, provides C_{IN} to supply hi-peak current instead of input supply.

Under Voltage Lockout

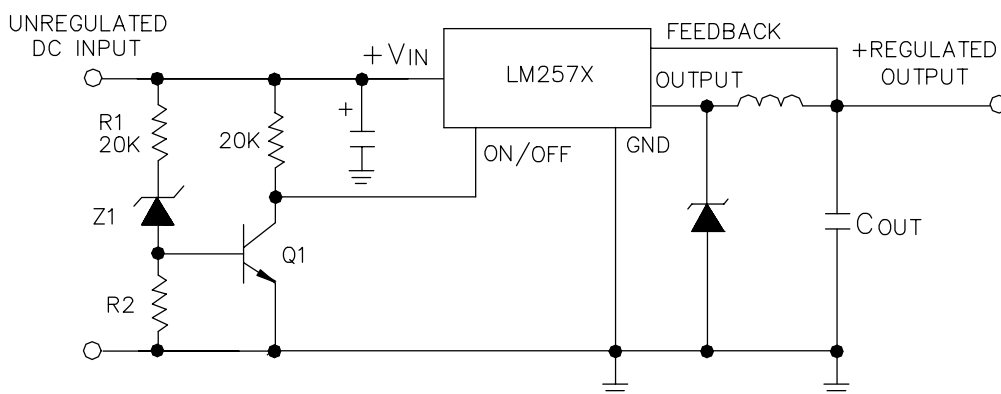

Regulator will be off until a V_{IN} set point is reached.

$$V_{IN} (ON) \cong V_z + 3V_{BE Q1}$$

Turn-On Delay With Spike Filter

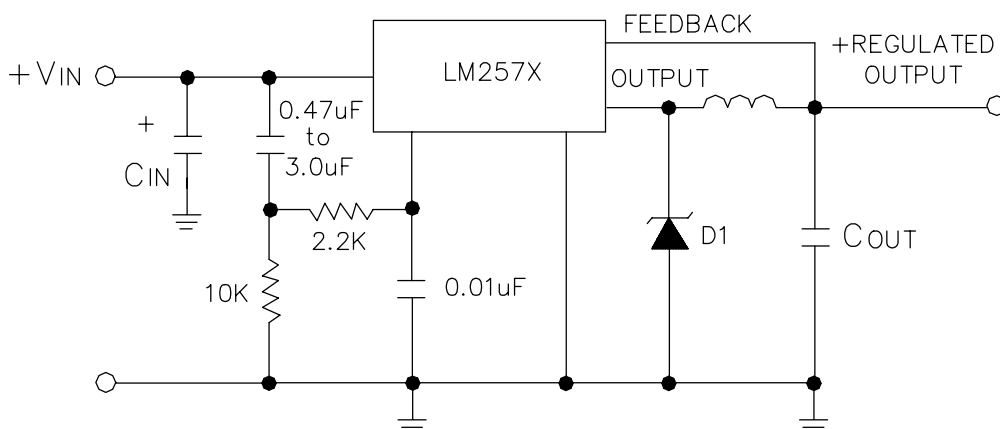

Spike filter reduces input noise, causing false triggering of delay.

POWER MANAGEMENT

Applications Information - Inverting Buck/Boost

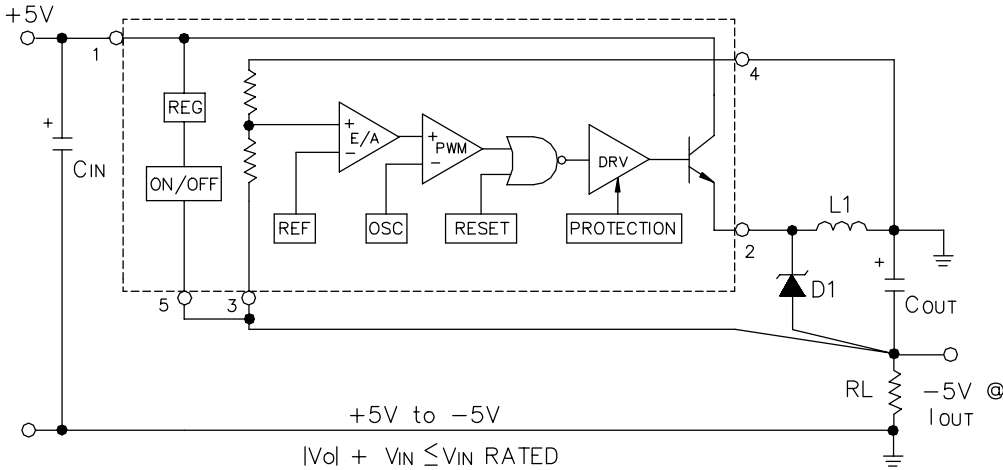

	LM2575	LM2576
C_{IN}	47 μ F	100 μ F
$D1$	3A	7A
$L1$	100 μ H	68 μ H
C_{OUT}	2,700 μ F	6,800 μ F
I_{OUT}	250mA	500mA

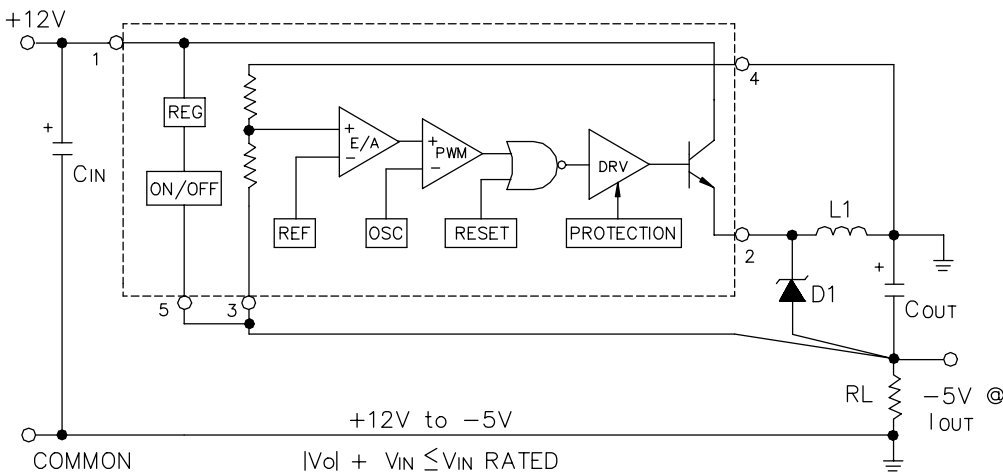

	LM2575	LM2576
C_{IN}	47 μ F	100 μ F
$D1$	3A	7A
$L1$	100 μ H	68 μ H
C_{OUT}	470 μ F	2,700 μ F
I_{OUT}	100mA	750mA

Inverting buck/boost operation is a different topology of operation than buck. This difference reduces the output current capability of the device, in that the inductor must supply all of the load current during the time the power switch is off. Maximum output current is approximately:

$$I_{OUT} \approx \frac{3.5}{2 \left(1 + \frac{|V_O|}{V_{IN}} \right)} \quad (\text{LM2576})$$

$$I_{OUT} \approx \frac{1.3}{2 \left(1 + \frac{|V_O|}{V_{IN}} \right)} \quad (\text{LM2575})$$

Component stress requirements are very similar to the buck with a few exceptions:

(1) catch diode breakdown V_{BR} must be greater than $V_{IN} + |V_{OUT}|$

(2) input capacitor is larger due to the increased peak current during switch turn on. Power dissipation is approximately:

$$P_D \approx \left(\frac{|V_O|}{|V_O| + V_{IN}} \right) I_O \left(1 + \frac{|V_O|}{V_{IN}} \right) V_{SAT} + 0.02 V_{IN} \frac{|V_O|}{V_{IN}}$$

Please contact factory for additional assistance when using the buck/boost topology.

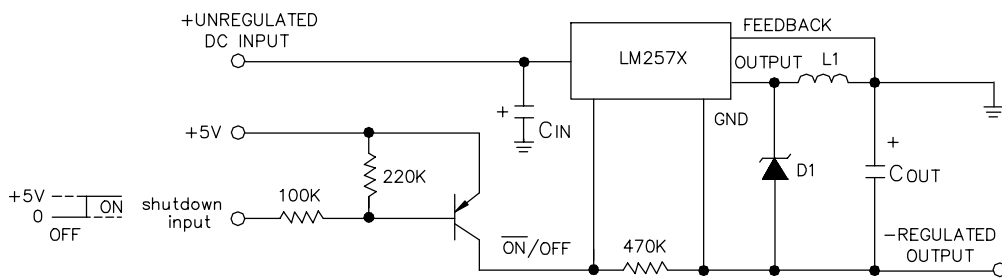
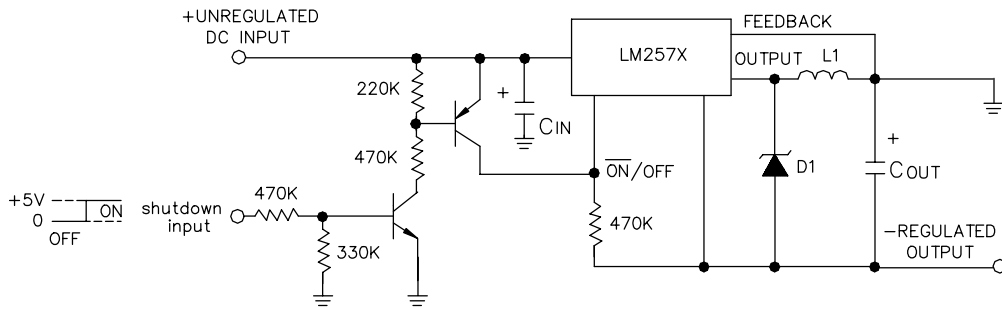
Inverting Buck/Boost Shutdown

POWER MANAGEMENT**Support Components Information****Pre-Wound Inductors:**

Hurricane Electronics Lab
P.O. Box 1280
Hurricane Industrial Park
Hurricane, UT 84737
(801) 635-2003

Core Source:

Micro Metals, Inc.
1190 N. Hawk Circle
Anaheim, CA 92807
(714) 630-7420

Capacitors:

VPR Series
Mallory Capacitor Co.
4760 Kentucky Avenue
Indianapolis, IN 46241
(317) 856-3731

511D & 673 Series
Sprague Electric Co.
North Adams, MA
(413) 664-4411

HFQ, HFZ Series
Panasonic Industrial Co.
2 Panasonic Way
Secaucus, NJ 07094
(201) 392-6142

PF, PL Series
Nichicon Corp.
927 E. State Pkwy.
Schaumburg, IL 60195
(708) 843-7600

LXF Series
United Chemi-con
9801 West Higgins Road
Rosemont, IL 60018
(708) 696-2000

Heat Sinks:

AAVID Engineering Co.
P.O.Box 400
One Kool Path
Laconia, NH 03247
(603) 528-3400

Thermalloy, Inc.
2021 W. Valley View Lane
Dallas, TX 76381
(214) 243-4321

Diodes - Catch:

Ultra Fast/Soft Recovery
Semtech Corporation
652 Mitchell Road
Newbury Park, CA 91320
(805) 498-2111

Diodes - Schottky:

Fuji/Collmer Semiconductor
14368 Proton Road
Dallas, TX 76244
(800) 527-0521

Micro Quality
1000 N. Shiloh
Garland, TX 76046
(214) 272-7811

POWER MANAGEMENT

Outline Drawing - TO-220-5 (T-XX Option)

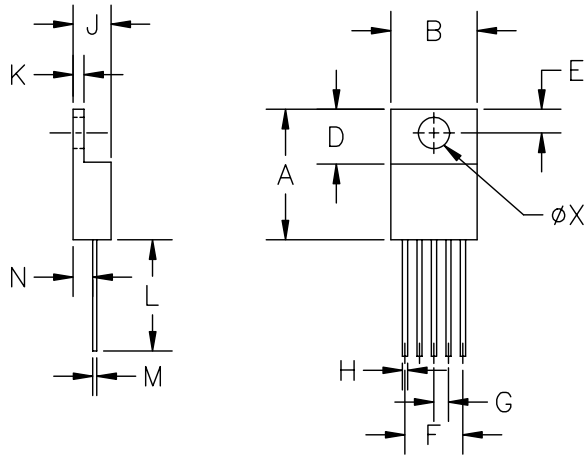

DIM ^N	INCHES		MM		NOTE
	MIN	MAX	MIN	MAX	
A	.560	.650	14.22	16.51	—
B	.380	.420	9.65	10.67	—
D	.230	.260	5.84	6.60	—
E	.100	.135	2.54	3.43	—
F	.263	.273	6.68	6.94	—
G	.062	.072	1.57	1.83	—
H	.025	.040	.63	1.02	—
J	.140	.190	3.55	4.83	—
K	.045	.055	1.14	1.40	—
L	.540	.560	13.72	14.22	—
M	.014	.022	.35	.56	—
N	.080	.120	2.03	3.05	—
φX	.139	.161	3.53	4.09	—

JEDEC TO-220

Outline Drawing - TO-220-5 (T-XX-H Option)

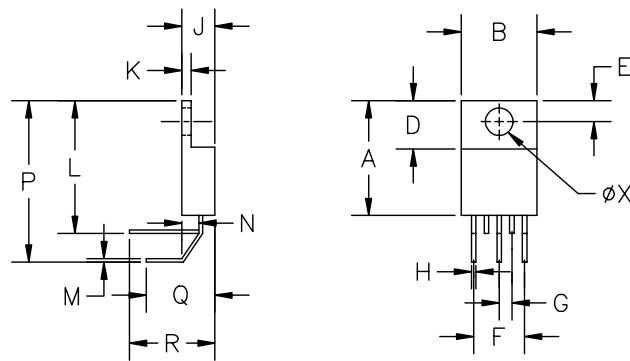

DIM ^N	INCHES		MM		NOTE
	MIN	MAX	MIN	MAX	
A	.560	.650	14.22	16.51	—
B	.380	.420	9.65	10.67	—
D	.230	.260	5.84	6.60	—
E	.100	.135	2.54	3.43	—
F	.263	.273	6.68	6.94	—
G	.062	.072	1.57	1.83	—
H	.025	.040	.63	1.02	—
J	.140	.190	3.55	4.83	—
K	.045	.055	1.14	1.40	—
L	.540	.560	13.72	14.22	—
M	.014	.022	.35	.56	—
N	.080	.120	2.03	3.05	—
P	.835	.865	21.21	21.97	—
Q	.332	.392	8.43	9.96	—
R	.420	.480	10.67	12.19	—
φX	.139	.161	3.53	4.09	—

JEDEC TO-220 (BODY ONLY)

Outline Drawing - TO-220-5 (T-XX-V Option)

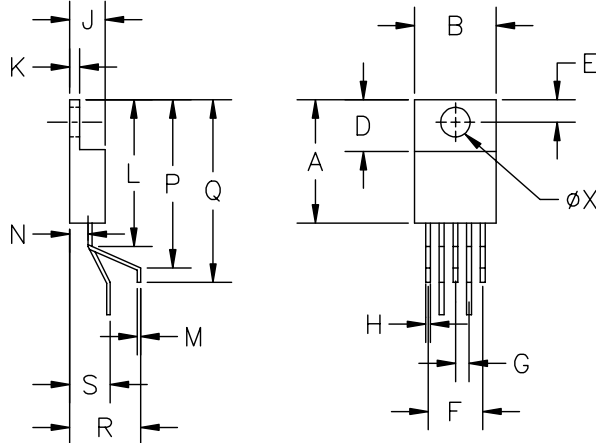

DIM ^N	INCHES		MM		NOTE
	MIN	MAX	MIN	MAX	
A	.560	.650	14.22	16.51	—
B	.380	.420	9.65	10.67	—
D	.230	.260	5.84	6.60	—
E	.100	.135	2.54	3.43	—
F	.263	.273	6.68	6.94	—
G	.062	.072	1.57	1.83	—
H	.025	.040	.63	1.02	—
J	.140	.190	3.55	4.83	—
K	.045	.055	1.14	1.40	—
L	.710	.730	18.03	18.54	—
M	.014	.022	.35	.56	—
N	.080	.120	2.03	3.05	—
P	.800	.850	20.32	21.59	—
Q	.876	.916	22.25	23.27	—
R	.330	.370	8.38	9.40	—
S	.180	.220	4.57	5.59	—
φX	.139	.161	3.53	4.09	—

JEDEC TO-220 (BODY ONLY)

POWER MANAGEMENT

Outline Drawing - TO-263-5

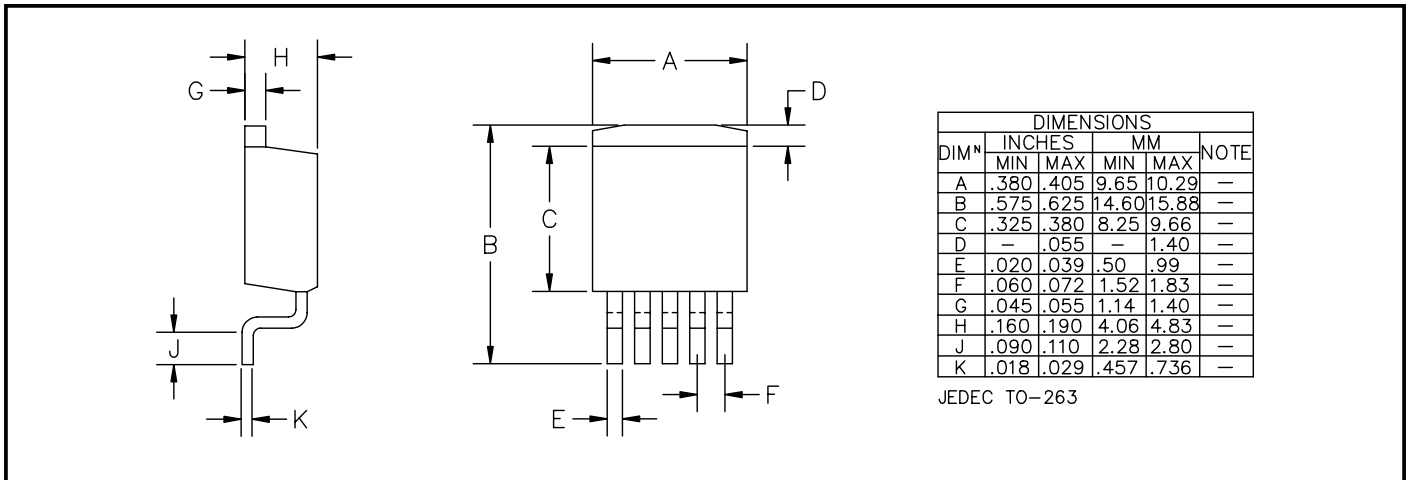

Minimum Land Pattern - TO-263-5

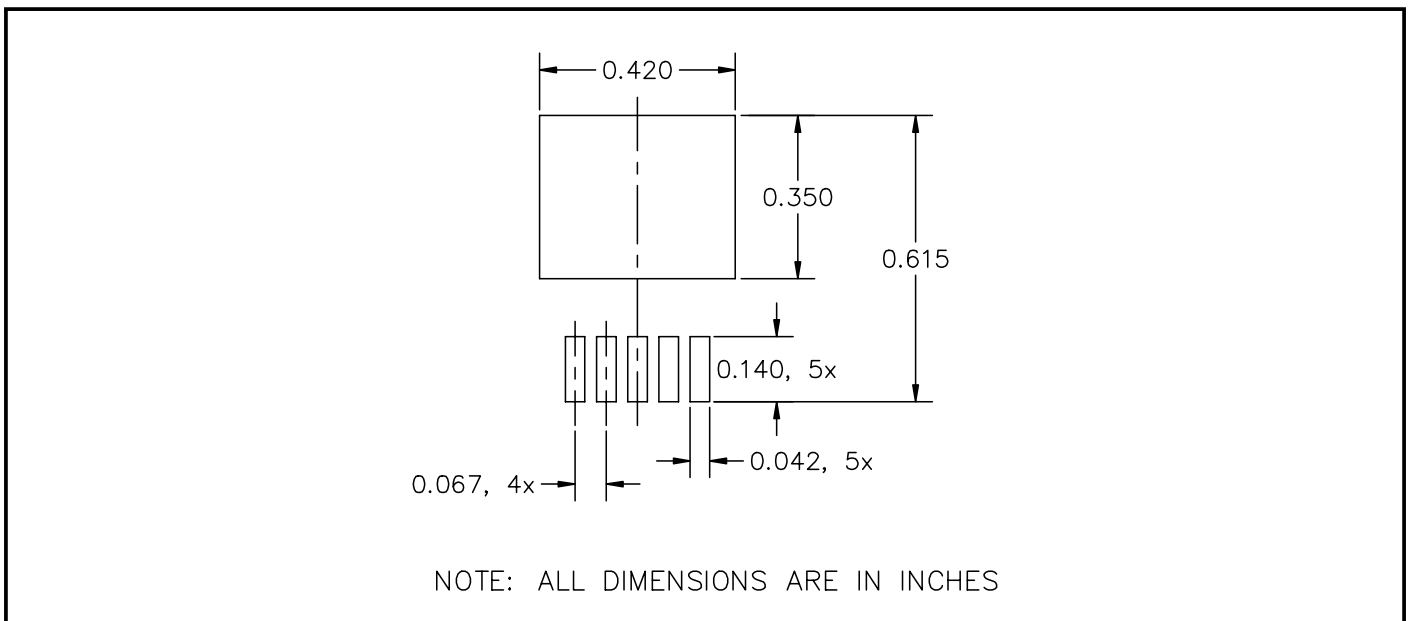

Contact Information

Semtech Corporation
 Power Management Products Division
 652 Mitchell Rd., Newbury Park, CA 91320
 Phone: (805)498-2111 FAX (805)498-3804