

POWER MANAGEMENT

Description

The EZ55Z3L voltage regulators are monolithic integrated circuits designed for use in applications requiring a well regulated positive output voltage with low input-to-output differential voltage requirements.

Outstanding features include full power usage up to 250mA of load current, internal current limiting and thermal shutdown. Safe area protection on the die is also included, providing protection of the series pass transistor under most operating conditions. TO-92 and SOT-223 packages are available for cost effective applications.

Features

- ◆ External capacitor not required for stability
- ◆ Low dropout performance
- ◆ Five fixed voltage options: 3.3V, 5V, 9V, 12V, 24V
- ◆ Adjustable output down to 1.25V
- ◆ Line regulation typically 0.015%
- ◆ Load regulation typically 0.1%
- ◆ TO-92 and SOT-223 packages

Typical Application Circuits

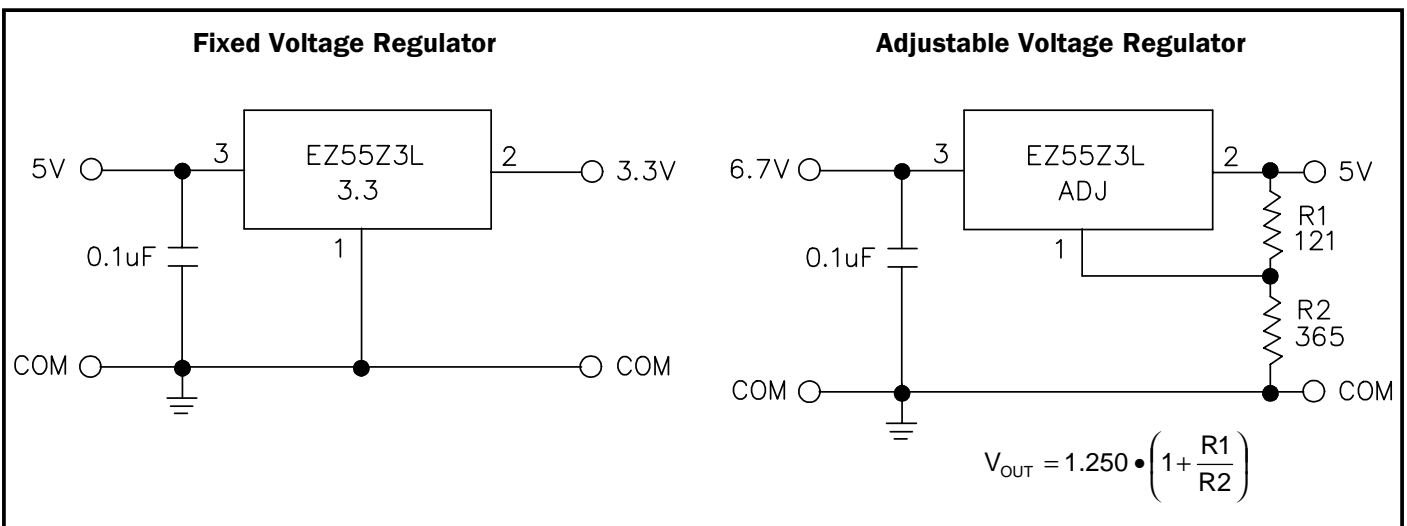

POWER MANAGEMENT
Absolute Maximum Ratings

Parameter	Symbol	Maximum	Units
Operating Input Voltage	V_{IN}	$V_{OUT} + 10$	V
Power Dissipation ⁽¹⁾	P_D	2.5	W
Thermal Resistance Junction to Ambient SOT-223 TO-92	θ_{JA}	62.3 132	°C/W
Thermal Resistance Junction to Case SOT-223 TO-92	θ_{JC}	15 66	°C/W
Operating Junction Temperature Range	T_J	0 to 125	°C
Storage Temperature Range	T_{STG}	-65 to 150	°C
Lead Temperature (Soldering) 10 Sec.	T_{LEAD}	300	°C
ESD Rating (Human Body Model)	V_{ESD}	2	kV

Note:

(1) Specifications are applicable for a power dissipation of 2.5W and are only achievable over a limited range of $V_{IN} - V_{OUT}$.

Electrical Characteristics

Unless otherwise specified: ($V_{IN} - V_{OUT}$) = 1.45V to 10V and $I_{OUT} = 10mA$ to 250mA. Values in **bold** apply over the full operating temperature range.

Parameter	Symbol	Conditions ⁽¹⁾	Min	Typ	Max	Units
Output Voltage ⁽²⁾	V_{OUT}	$V_{IN} = V_{OUT} + 3V, I_{OUT} = 10mA$	-3%	V_{OUT}	+3%	V
Fixed Voltage Version			-4%		+4%	
Reference Voltage ⁽²⁾	V_{REF}	$V_{IN} = V_{OUT} + 3V, I_{OUT} = 10mA$	1.213	1.250	1.288	V
Adj. Voltage Version			1.200		1.300	
Line Regulation ⁽²⁾	$REG_{(LINE)}$	$I_{OUT} = 10mA$		0.015	0.2	%
			0.035	0.2		
Load Regulation ⁽²⁾	$REG_{(LOAD)}$	$V_{IN} = 3V$		0.1	0.3	%
			0.2	0.4		
Dropout Voltage	V_D			1.3	1.5	V
$\Delta V_{OUT}, \Delta V_{REF} = 1\%$						
Surge Current Limit	I_S			0.5		A
Quiescent Current	I_Q	$V_{IN} = 10V$		10	15	mA
Thermal Regulation ⁽³⁾	$REG_{(THERM)}$			0.002	0.01	%/W

POWER MANAGEMENT
Electrical Characteristics (Cont.)

Unless otherwise specified: ($V_{IN} - V_{OUT}$) = 1.45V to 10V and I_{OUT} = 10mA to 250mA. Values in **bold** apply over the full operating temperature range.

Parameter	Symbol	Conditions ⁽¹⁾	Min	Typ	Max	Units
Adjust Pin Current	I_{ADJ}			55		μ A
					120	
Adjust Pin Current Change	ΔI_{ADJ}			0.2	5	μ A
Temperature Stability	T_S	$V_{IN} = 5V, I_{OUT} = 250mA$		0.5		%
Minimum Load Current	I_{OUT}	$V_{IN} = 10V$		5	10	mA
RMS Output Noise ⁽⁴⁾	V_N			0.003		% V_{OUT}
Ripple Rejection Ratio ⁽⁵⁾	R_A	$V_{IN} = 5V, I_{OUT} = 250mA$	60	72		dB

Notes:

(1) Specifications are applicable for a power dissipation of 2.5W and are only achievable over a limited range of $V_{IN} - V_{OUT}$.

(2) Low duty cycle pulse testing with Kelvin connections required. Changes in output voltage due to heating effects are covered under the specification for thermal regulation.

(3) 30ms pulse.

(4) Bandwidth of 10Hz to 10kHz

(5) 120Hz input ripple, 1 dB less for each volt increase above 3.3V Min.; C_{OUT} & C_{ADJ} (for ADJ) = 25 μ F.

POWER MANAGEMENT

Pin Configurations

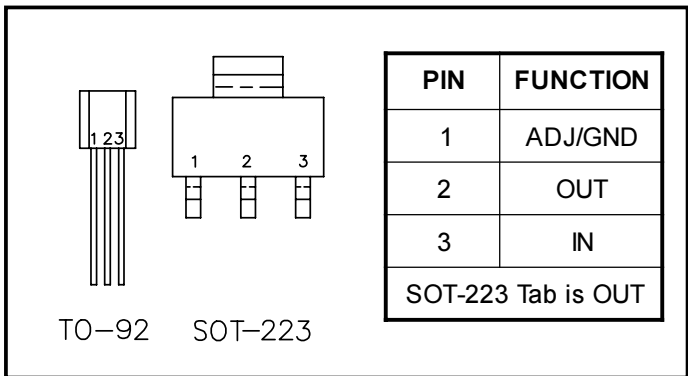

PIN	FUNCTION
1	ADJ/GND
2	OUT
3	IN

SOT-223 Tab is OUT

Ordering Information

Device ⁽¹⁾	Package
EZ55Z3L-SX.TR ⁽²⁾	SOT-223
EZ55Z3L-ZX.TR ⁽³⁾	TO-92

Notes:

- (1) Where X denotes voltage options. Available voltages are: 3.3V, 5V, 9V, 12V and 24V. Replace X with "ADJ" for adjustable version (1.25 to 24V).
- (2) Only available in tape and reel packaging. A reel contains 2500 devices.
- (3) Available in tape and reel packaging (a reel contains 3000 devices) or ammo pack (suffix TA, an ammo pack contains 2000 devices).

Block Diagram

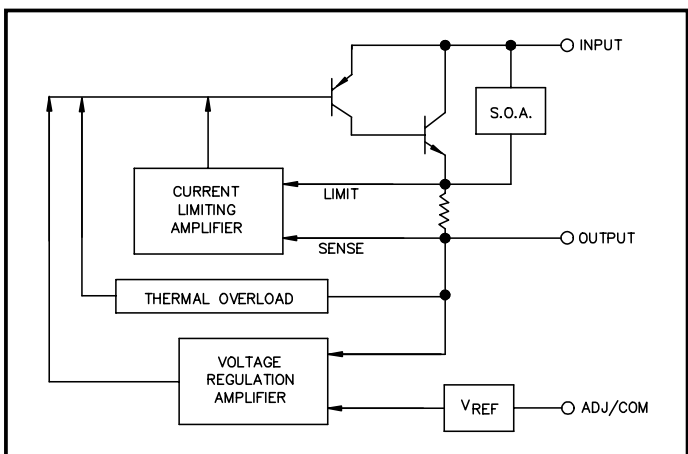

POWER MANAGEMENT

Outline Drawing - SOT-223

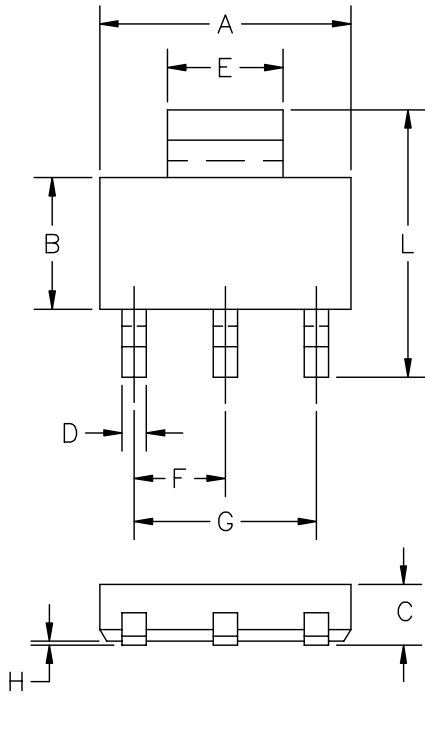

DIM ^N	INCHES		MM		NOTE
	MIN	MAX	MIN	MAX	
A	.248	.264	6.30	6.70	—
B	.13	.146	3.30	3.70	—
C	.060	.071	1.52	1.80	—
D	.024	.031	.60	.80	—
E	.114	.122	2.90	3.10	—
F	—	.090	—	2.30	BSC
G	—	.181	—	4.60	BSC
H	.001	.004	.020	.100	—
J	.164	.215	4.16	5.46	—
K	.036	.05	.91	1.27	—
L	.264	.287	6.70	7.30	—
M	.009	.013	.24	.32	—

CONTROLLING DIMENSIONS: MILLIMETERS.

Land Pattern - SOT-223

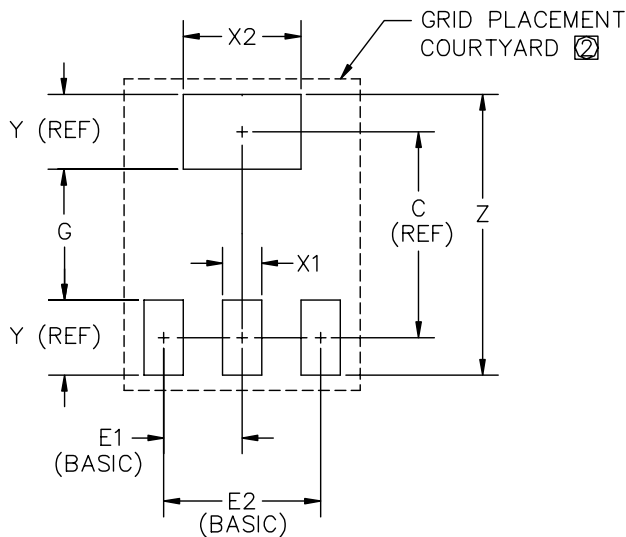

DIM ^N	INCHES		MM		NOTE
	MIN	MAX	MIN	MAX	
C	—	.24	—	6.20	—
E1	—	.09	—	2.30	—
E2	—	.18	—	4.60	—
G	.15	.16	4.00	4.20	—
X1	.03	.04	1.00	1.20	—
X2	.13	.14	3.40	3.60	—
Y	—	.09	—	2.20	—
Z	.32	.33	8.20	8.40	—

② GRID PLACEMENT COURTYARD IS 18 X 14 ELEMENTS (9 mm X 7mm) IN ACCORDANCE WITH THE INTERNATIONAL GRID DETAILED IN IEC PUBLICATION 97.

① CONTROLLING DIMENSION: MILLIMETERS

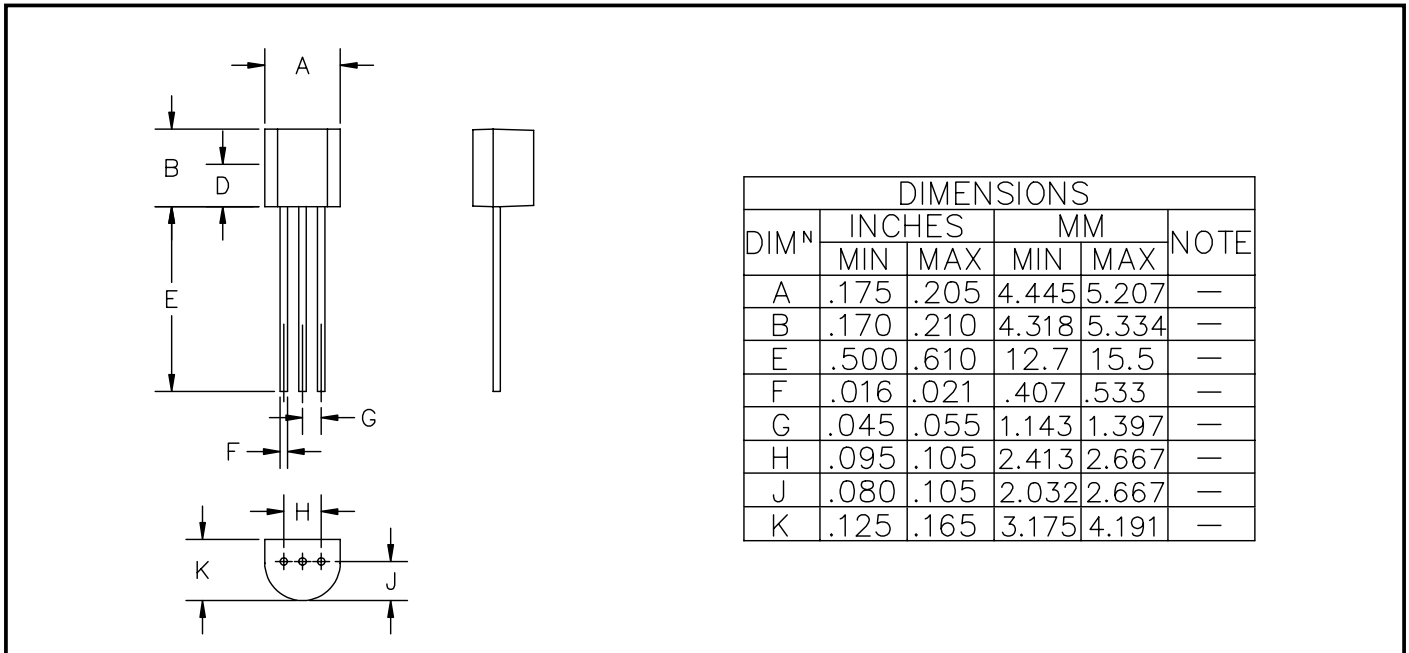
POWER MANAGEMENT
Outline Drawing - TO-92

Contact Information

Semtech Corporation
 Power Management Products Division
 652 Mitchell Rd., Newbury Park, CA 91320
 Phone: (805)498-2111 FAX (805)498-3804