

January 30, 1998

 TEL:805-498-2111 FAX:805-498-3804 WEB:<http://www.semtech.com>

## DESCRIPTION

The SC1630 is a DC-DC converter designed to drive an external power switch for more flexibility, especially in higher voltage and larger power applications. Typically six components are required to set up a step-up configuration easily achieving an efficiency beyond 80%. A few more components are required to set up a step down configuration delivering 4A load current with 83% typical efficiency, 86% at 2A load, and 300 $\mu$ A quiescent current.

The output voltage can be internally set to 5V or externally set to an arbitrary value below breakdown voltage of the power switch. Logic-controlled shutdown mode is provided for power-saving. The low battery detector can also be configured as a linear regulator.

A 120kHz switching rate reduces the inductor size. Inductors of 25 $\mu$ H to 50 $\mu$ H inductance are recommended for most applications.

## APPLICATIONS

- Palmtop and notebook computers
- Battery charger supply
- Cellular telephones
- LCD contrast supply
- Flash memory programmer
- Battery backup supplies
- Portable instruments

## PIN CONFIGURATION

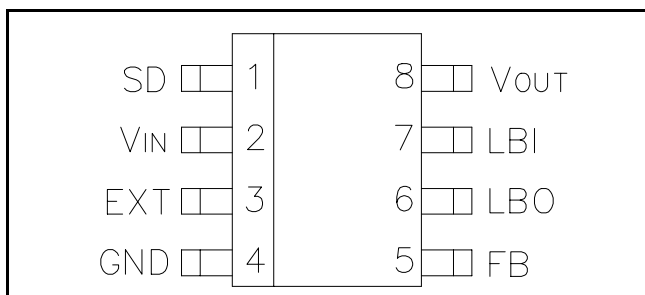

## FEATURES

- Default +5V output voltage
- Adjustable output voltage with two resistors
- Power-saving shutdown mode (7 $\mu$ A typical)
- 120kHz switching rate
- On-chip low battery detector

## BLOCK DIAGRAM

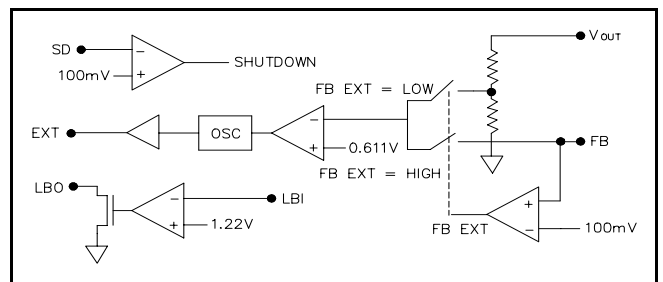

## ORDERING INFORMATION

DEVICE <sup>(1)</sup>	PACKAGE
SC1630CS	SO-8

Note:

(1) Add suffix 'TR' for tape and reel.

## ABSOLUTE MAXIMUM RATINGS

Parameter	Symbol	Maximum	Units
Supply Voltage	V <sub>IN</sub>	7.0	V
Operating Temperature Range	T <sub>A</sub>	0 to 70	°C
Storage Temperature Range	T <sub>STG</sub>	-65 to 125	°C

January 30, 1998

**ELECTRICAL CHARACTERISTICS**

 Unless otherwise specified,  $T_A = 25^\circ\text{C}$ ,  $V_{IN} = 3.0\text{V}$ 

Parameter	Conditions	Min	Typ	Max	Units
Input Voltage		1.8		7.0	V
Default Output Voltage	$I_L = 200\text{mA}$	4.80	5.00	5.20	V
Switch Off Current			105	140	$\mu\text{A}$
Shutdown Mode Current			7	15	$\mu\text{A}$
Recovery Time from Shutdown	$V_{IN} = 2.5\text{V}, I_L = 200\text{mA}$		0.4		ms
Efficiency	$I_L = 300\text{mA}$ (5V Output Step-Up Converter)		85		%
Line Regulation	$V_{IN} = 2.2 - 3.3\text{V}$ $V_{OUT} = 5\text{V}, I_L = 100\text{mA}$		0.6		$\%V_{OUT}$
Load Regulation	$I_L = 10\text{mA} - 500\text{mA}$ $V_{OUT} = 5\text{V}$		2.5		$\%V_{OUT}$
Oscillator Frequency		90	120	150	kHz
LBI Pin Trip Point			1.22		V
EXT Pin Driving Capabilities	Pin 8 = 5V, Pin 3 = 0.85V Sourcing Sinking		80 50		mA mA
LBO "ON Resistance"	$V_{IN} = 2\text{V}$		45		$\Omega$
Input Pin Bias Current				10	nA/Pin
Output Pin Leakage				10	nA/Pin

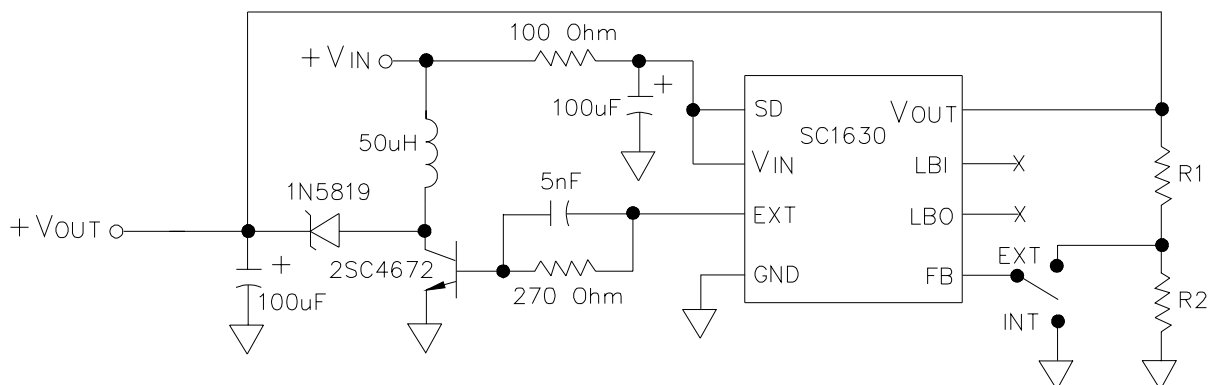
**TYPICAL APPLICATIONS**

January 30, 1998

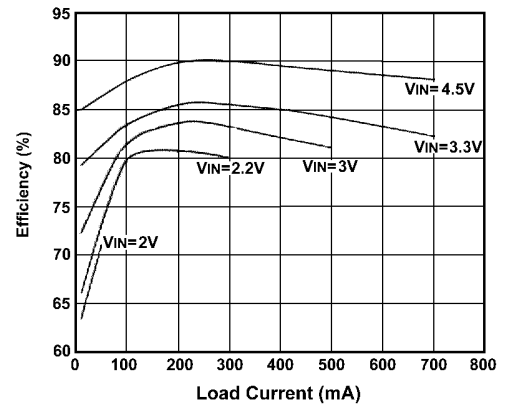
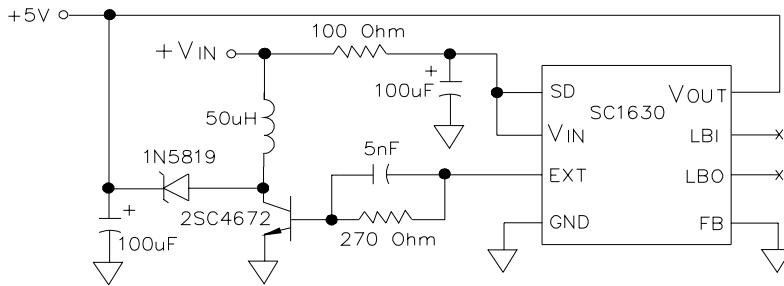
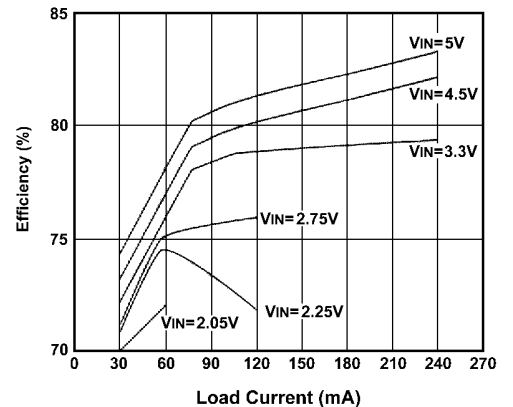
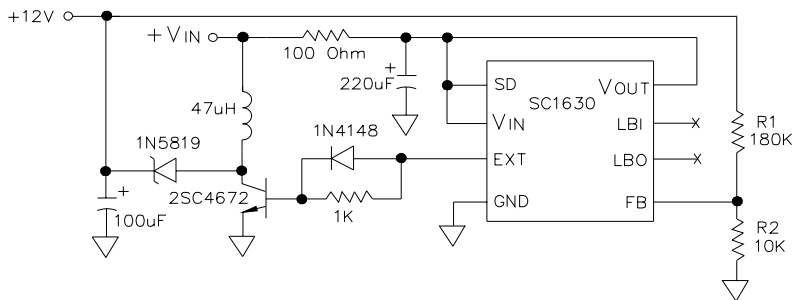
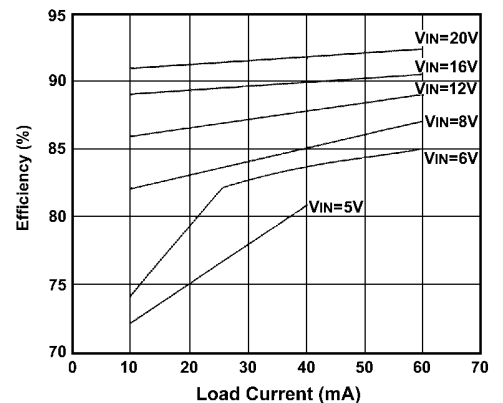
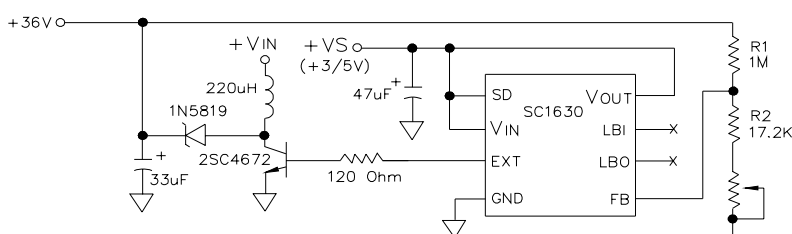
**TYPICAL APPLICATIONS (cont.)**
**5V Output Step-Up Converter**

**12V Output Step-Up Converter for Flash Memory**

**36V Output Step-Up Converter for Color LCD**

January 30, 1998

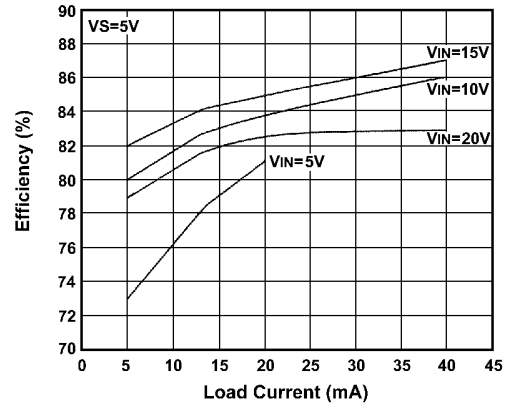
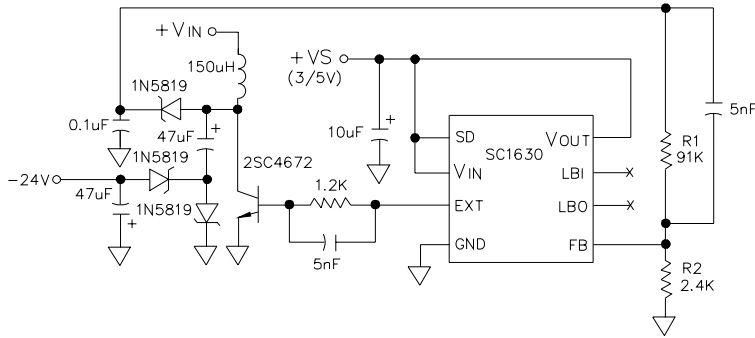
**TYPICAL APPLICATIONS (cont.)**

**-24V Output Inverting Converter for LCD**



**2V Input 20mA Load -24V Output Inverting Converter for LCD**

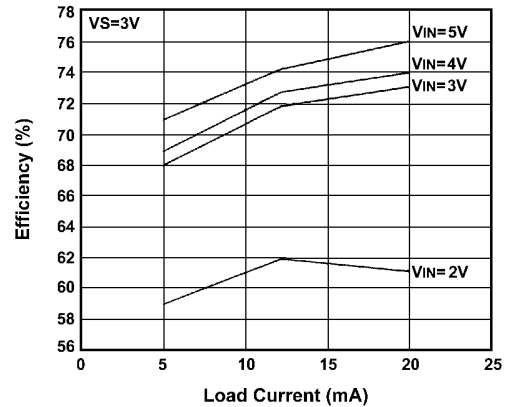
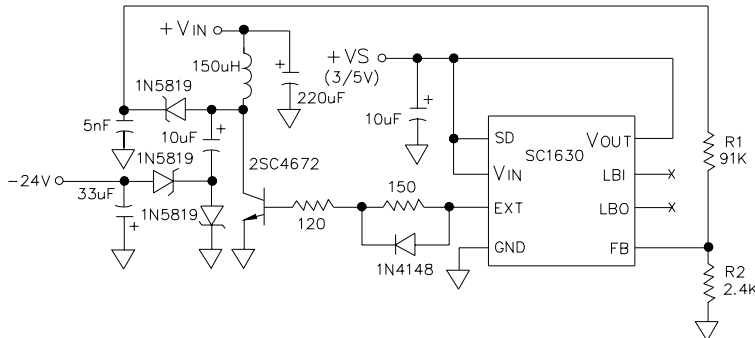

**±12V Dual Output Converter for Computer Interfacing**

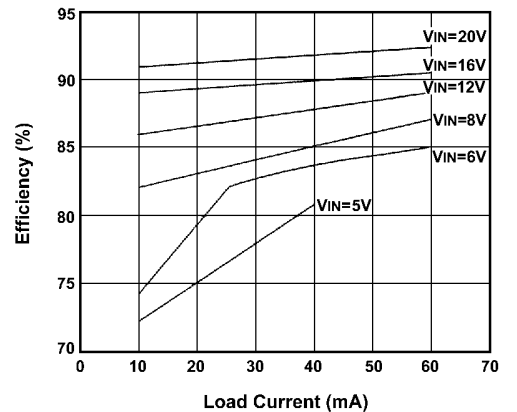
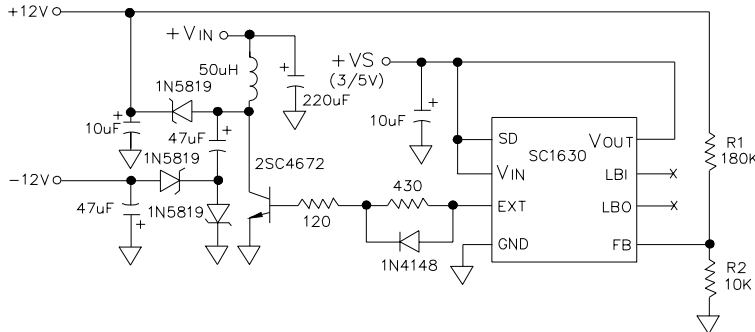

January 30, 1998

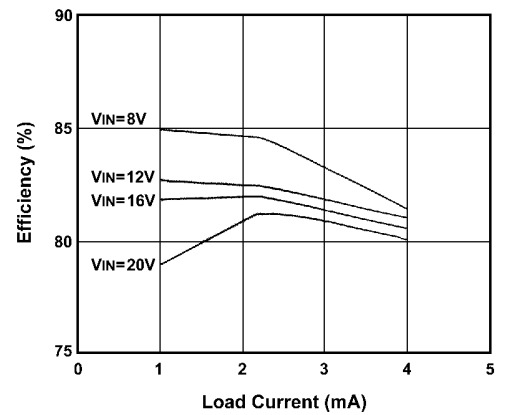
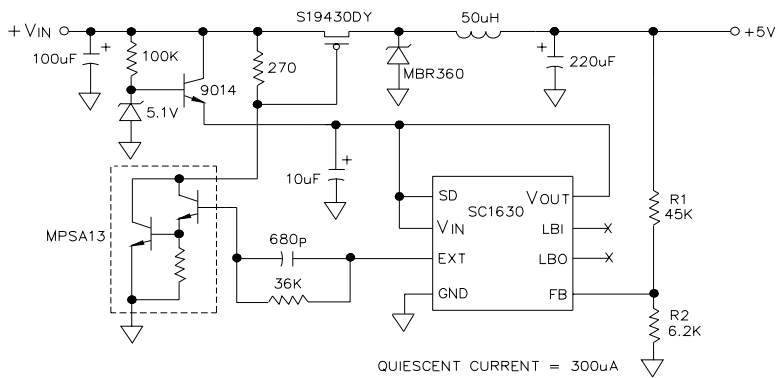
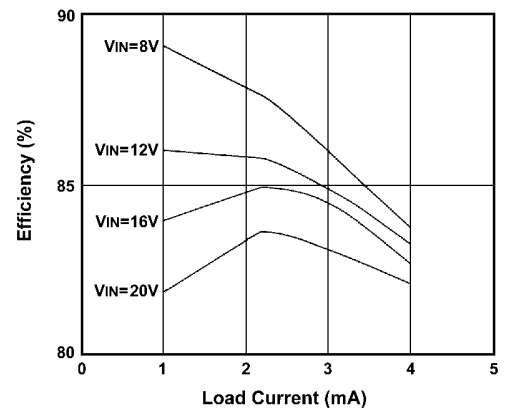
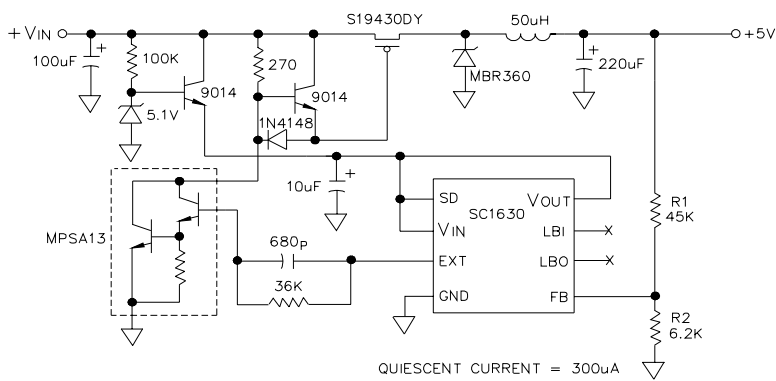
**TYPICAL APPLICATIONS (cont.)**
**5V Output Step-Down Converter - 1**

**5V Output Step-Down Converter - 2**

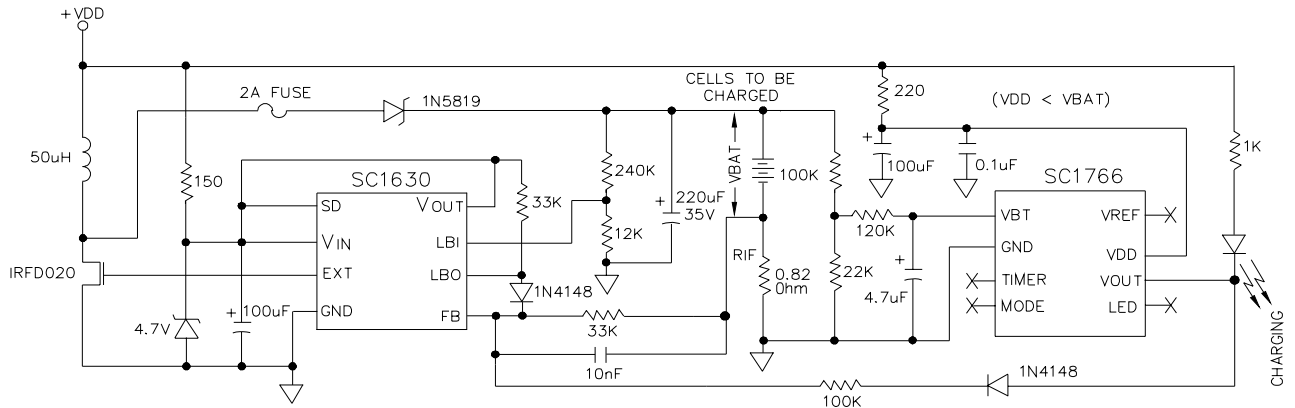
January 30, 1998

**TYPICAL APPLICATIONS (cont.)**
**Step-Up Rechargeable Battery Charger**

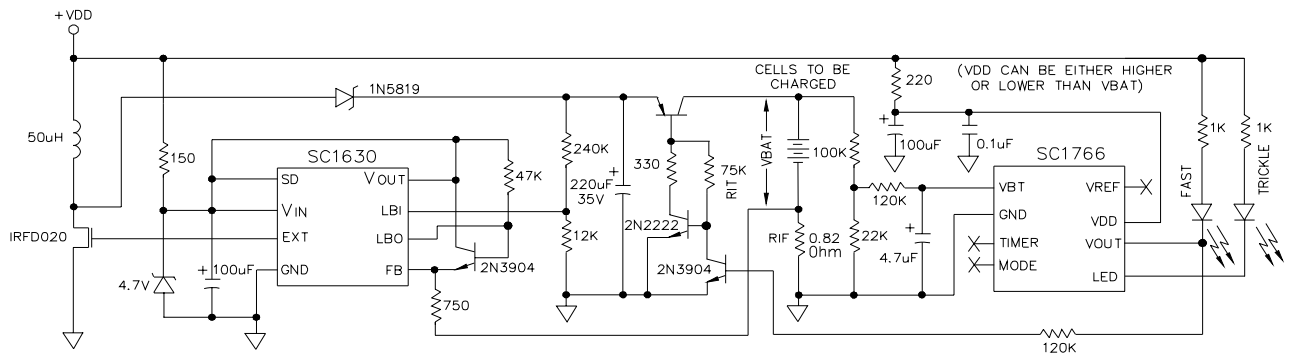
- Charging current = 0.8A, Auto Cut-Off at 0.25% -Delta-V point and fault conditions (RIF sets the charging current).
- VDD must be lower than VBAT.
- Short circuit condition is protected with a 2A fuse.

**Step-Up/Step-Down Rechargeable Battery Charger**

- Fast charge current = 0.8A when  $VDD < VBAT$ , =  $(VDD - VBAT - 0.5) / 0.82$  when  $VDD > VBAT$ .
- Trickle charge current = 30mA (RIF sets fast charge current, RIT sets trickle charge current).
- Typical efficiency = 75%.
- With short circuit protection.

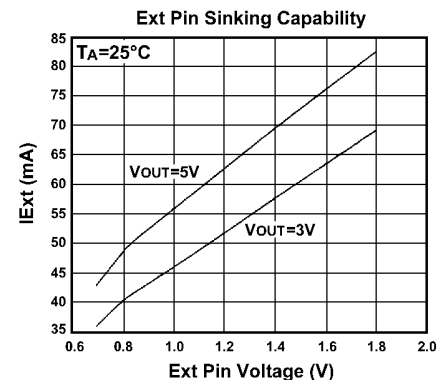
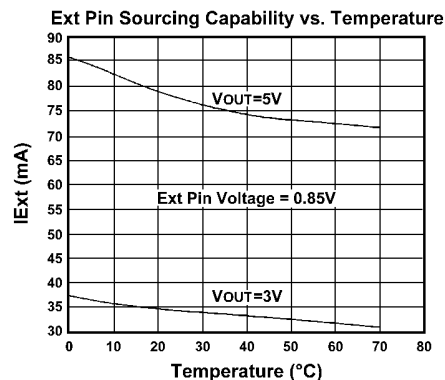
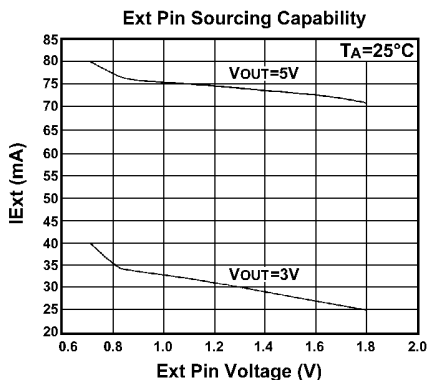
**TYPICAL PERFORMANCE CHARACTERISTICS**

January 30, 1998

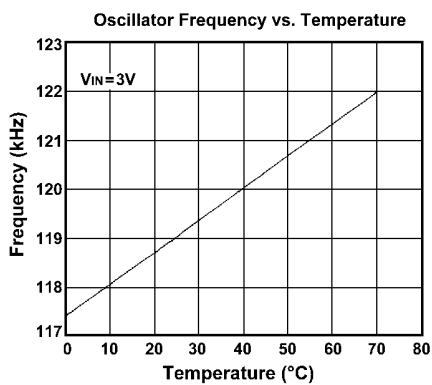
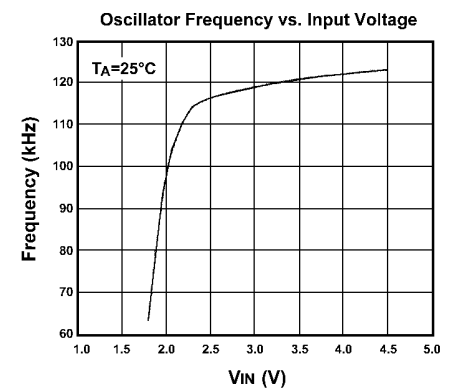
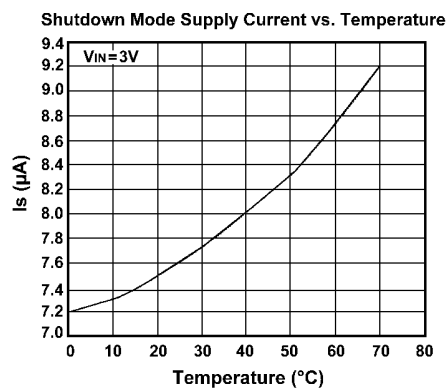
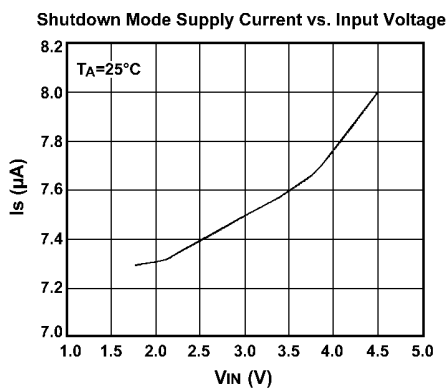
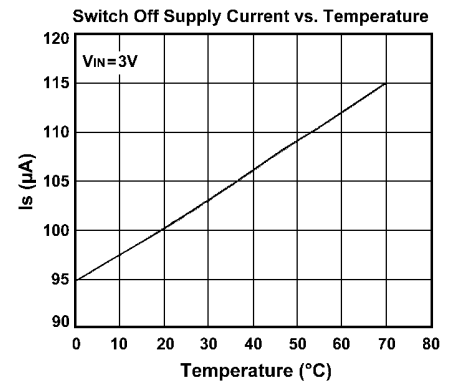
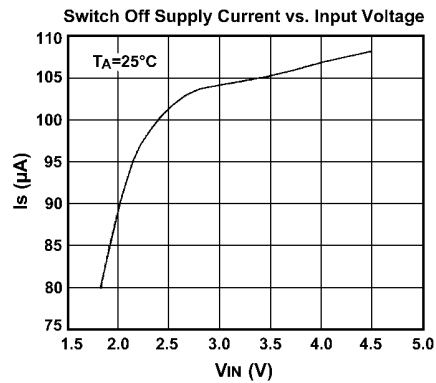
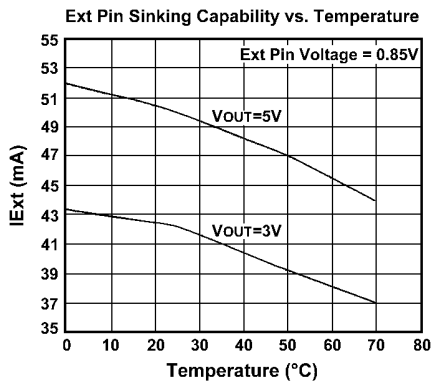
**TYPICAL PERFORMANCE CHARACTERISTICS (cont.)**

January 30, 1998

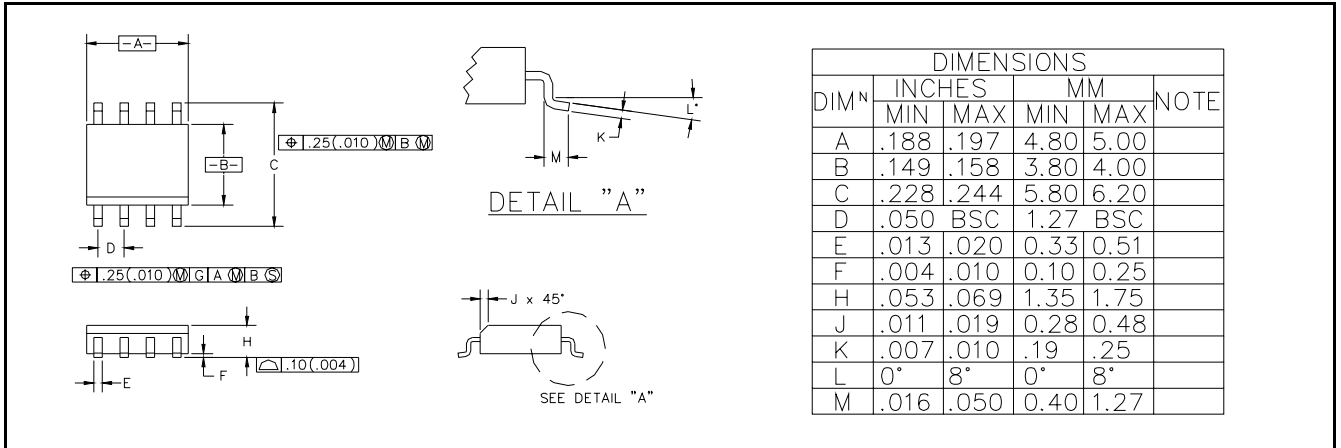
**DEVICE OUTLINE - SO-8**

**PIN DESCRIPTIONS**

- PIN 1: SD** The SC1630 goes into shutdown mode and consumes less than 10µA when the SD pin is pulled to ground, and it goes into normal operating mode when the SD pin is pulled to a positive voltage above 100mV.
- PIN 2: V<sub>IN</sub>** Input supply.
- PIN 3: EXT** Push-Pull driver output to drive external power switch.
- PIN 4: GND** Ground.
- PIN 5: FB** The output voltage can either be internally set to 5 volts by grounding the FB pin, or it can be externally set to an arbitrary voltage by applying to the FB pin the divider voltage of two external divider resistors. V<sub>OUT</sub> voltage is given by the following equation:

$$V_{OUT} = 0.611 \left( 1 + \frac{R_1}{R_2} \right)$$

- Where: R1= Resistor connected between FB Pin and V<sub>OUT</sub> pin.  
 R2= Resistor connected between FB Pin and ground.  
 V<sub>OUT</sub> = Output voltage to be set.

- PIN 6: LBO** Open drain output of the battery low detector, with 45 Ohm "On Resistance" at V<sub>IN</sub>=2V. It is pulled low when the voltage on LBI pin is below 1.22 volts.
- PIN 7: LBI** The inverting input of the battery low detector, of which the non-inverting input is internally connected to the 1.22V voltage reference.
- PIN 8: V<sub>OUT</sub>** The output voltage feeds back to the IC through this pin for internally set 5V operation. If the output voltage is externally set, the V<sub>OUT</sub> pin can be tied to any low impedance node with voltage between the external power switch threshold and 7 volts.

**PIN CONFIGURATION**
