

PRELIMINARY - April 13, 1998

 TEL:805-498-2111 FAX:805-498-3804 WEB:<http://www.semtech.com>
**DESCRIPTION**

The SC4041 is a two terminal precision voltage reference with thermal stability guaranteed over temperature. The very low fixed output voltage of 1.225 V is ideal for use with today's low voltage integrated circuits. The SC4041 has a typical dynamic output impedance of 0.25Ω. Active output circuitry provides a very sharp turn on characteristic - the minimum operating current is 60μA, with a maximum of 20mA.

Available with five voltage tolerances (0.1%, 0.2%, 0.5%, 1.0% and 2.0%) and three package outlines (SOT-23, SO-8 and TO-92), this part allows the designer the opportunity to select the optimum combination of cost and performance for their application.

**FEATURES**

- Low voltage operation (1.225V)
- Trimmed bandgap design (0.1%)
- Wide operating current range 60μA to 20mA
- Low dynamic impedance (0.25Ω)
- Available in SOT-23, TO-92 and SO-8

**APPLICATIONS**

- Cellular telephones
- Portable computers
- Instrumentation
- Automotive

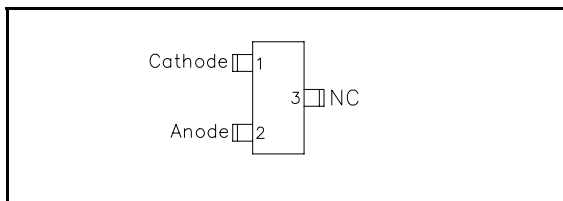
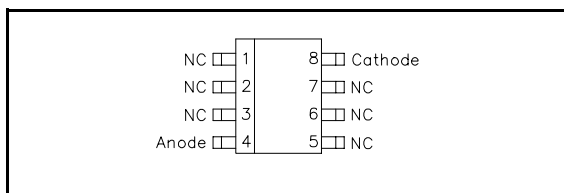
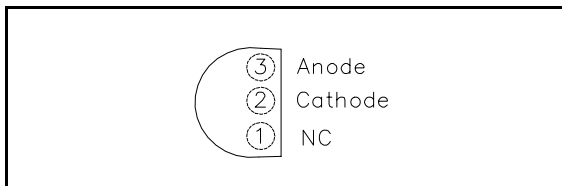
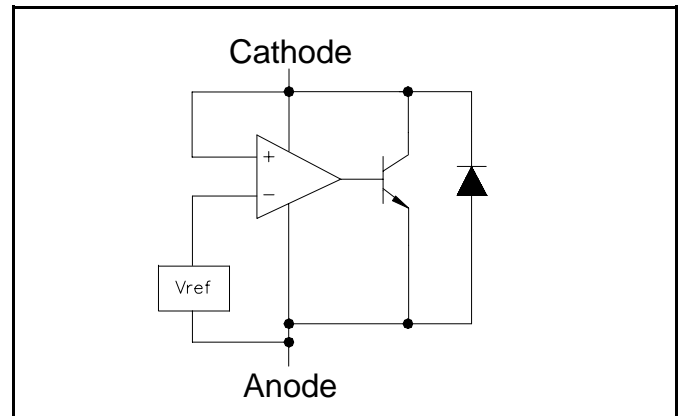
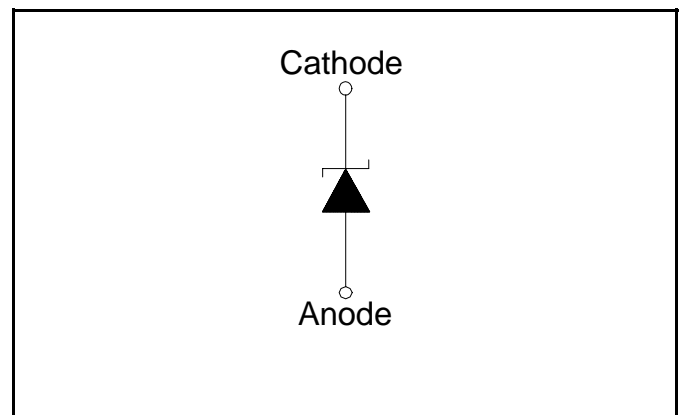
**PIN CONFIGURATIONS**
**SOT-23-3 Lead (Top View)**

**SO-8 Lead (Top View)**

**TO-92 (Top View)**

**BLOCK DIAGRAM**

**SYMBOL DIAGRAM**

PRELIMINARY - April 13, 1998

**ABSOLUTE MAXIMUM RATINGS**

Parameter	Symbol	Maximum	Units
Reverse Current		60 $\mu$ A to 20	mA
Operating Temperature Range	$T_A$	-40 to +85	$^{\circ}$ C
Operating Junction Temperature Range	$T_J$	-40 to +150	$^{\circ}$ C
Storage Temperature Range	$T_{STG}$	-65 to +150	$^{\circ}$ C
Lead Temperature (Soldering) 10 seconds	$T_{LEAD}$	260	$^{\circ}$ C
ESD Rating	ESD	2	kV

**ORDERING INFORMATION**

PACKAGE	TOLERANCE					T/R Quantity
	0.1%	0.2%	0.5%	1.0%	2.0%	
SOT-23-3L <sup>(1)</sup>	SC4041ASK	SC4041BSK	SC4041CSK	SC4041DSK	SC4041ESK	3K
SO-8 <sup>(1)</sup>	SC4041AS	SC4041BS	SC4041CS	SC4041DS	SC4041ES	2.5K
TO-92 <sup>(1)(2)</sup>	SC4041AZ	SC4041BZ	SC4041CZ	SC4041DZ	SC4041EZ	TR=3K, TA=2K

Notes:

(1) Add suffix 'TR' for Tape &amp; Reel.

(2) Add suffix 'TA' for Tape Ammo.

PRELIMINARY - April 13, 1998

**ELECTRICAL CHARACTERISTICS**

T <sub>A</sub> = 25°C unless otherwise specified.				SC4041A (0.1%)			SC4041B (0.2%)			
Parameter	Symbol	Condition		MIN	TYP	MAX	MIN	TYP	MAX	UNITS
Reverse Breakdown Voltage	V <sub>Z</sub>	I <sub>Z</sub> = 100µA	T <sub>A</sub> = 25°C	1.2238	1.2250	1.2262	1.2226	1.2250	1.2274	V
			T <sub>A</sub> = -40 to +85°C	1.2158	1.2250	1.2342	1.2146	1.2250	1.2354	V
Minimum Operating Current	I <sub>Z(min)</sub>				30	60		30	60	µA
Reverse Breakdown Voltage Temperature Coefficient	$\frac{\Delta V_Z}{\Delta T}$	I <sub>Z</sub> = 10mA I <sub>Z</sub> = 1mA I <sub>Z</sub> = 100µA	T <sub>A</sub> = -40 to +85°C			±100			±100	ppm/°C
Ratio of Change in V <sub>Z</sub> to Change in I <sub>Z</sub>	$\frac{\Delta V_Z}{\Delta I_Z}$	I <sub>Z(min)</sub> ≤ I <sub>Z</sub> ≤ 1mA	T <sub>A</sub> = 25°C			1.5			1.5	mV
			T <sub>A</sub> = -40 to +85°C			2.0			2.0	mV
		1mA ≤ I <sub>Z</sub> ≤ 12mA	T <sub>A</sub> = 25°C			6.0			6.0	mV
			T <sub>A</sub> = -40 to +85°C			8.0			8.0	mV
Reverse Dynamic Impedance	Z <sub>R</sub>	I <sub>Z</sub> = 1mA, f = 120 Hz, I <sub>AC</sub> = 0.1 I <sub>Z</sub>			0.25	1.5		0.25	1.5	Ω
Wideband Noise (RMS)	e <sub>N</sub>	I <sub>Z</sub> = 100µA 10Hz ≤ f ≤ 10kHz			20			20		µV
Long Term Stability of Reverse Breakdown Voltage	ΔV <sub>Z</sub>	t = 1000 hours T = 25°C ± 0.1°C I <sub>Z</sub> = 100µA			120			120		ppm

T <sub>A</sub> = 25°C unless otherwise specified.				SC4041C (0.5%)			SC4041D (1.0%)			
Parameter	Symbol	Condition		MIN	TYP	MAX	MIN	TYP	MAX	UNITS
Reverse Breakdown Voltage	V <sub>Z</sub>	I <sub>Z</sub> = 100µA	T <sub>A</sub> = 25°C	1.219	1.225	1.231	1.213	1.225	1.237	V
			T <sub>A</sub> = -40 to +85°C	1.211	1.225	1.239	1.201	1.225	1.249	V
Minimum Operating Current	I <sub>Z(min)</sub>				30	60		30	60	µA
Reverse Breakdown Voltage Temperature Coefficient	$\frac{\Delta V_Z}{\Delta T}$	I <sub>Z</sub> = 10mA I <sub>Z</sub> = 1mA I <sub>Z</sub> = 100µA	T <sub>A</sub> = -40 to +85°C			±100			±150	ppm/°C
Ratio of Change in V <sub>Z</sub> to Change in I <sub>Z</sub>	$\frac{\Delta V_Z}{\Delta I_Z}$	I <sub>Z(min)</sub> ≤ I <sub>Z</sub> ≤ 1mA	T <sub>A</sub> = 25°C			1.5			2.0	mV
			T <sub>A</sub> = -40 to +85°C			2.0			2.5	mV
		1mA ≤ I <sub>Z</sub> ≤ 12mA	T <sub>A</sub> = 25°C			6.0			8.0	mV
			T <sub>A</sub> = -40 to +85°C			8.0			10.0	mV
Reverse Dynamic Impedance	Z <sub>R</sub>	I <sub>Z</sub> = 1mA, f = 120 Hz, I <sub>AC</sub> = 0.1 I <sub>Z</sub>			0.25	1.5		0.25	2.0	Ω
Wideband Noise (RMS)	e <sub>N</sub>	I <sub>Z</sub> = 100µA 10Hz ≤ f ≤ 10kHz			20			20		µV
Long Term Stability of Reverse Breakdown Voltage	ΔV <sub>Z</sub>	t = 1000 hours T = 25°C ± 0.1°C I <sub>Z</sub> = 100µA			120			120		ppm

PRELIMINARY - April 13, 1998

**ELECTRICAL CHARACTERISTICS**

T <sub>A</sub> = 25°C unless otherwise specified.				SC4041E (2.0%)			
Parameter	Symbol	Condition		MIN	TYP	MAX	UNITS
Reverse Breakdown Voltage	V <sub>Z</sub>	I <sub>Z</sub> = 100µA	T <sub>A</sub> = 25°C	1.200	1.225	1.250	V
			T <sub>A</sub> = -40 to +85°C	1.189	1.225	1.261	V
Minimum Operating Current	I <sub>Z(min)</sub>				30	60	µA
Reverse Breakdown Voltage Temperature Coefficient	$\frac{\Delta V_Z}{\Delta T}$	I <sub>Z</sub> = 10mA I <sub>Z</sub> = 1mA I <sub>Z</sub> = 100µA	T <sub>A</sub> = -40 to +85°C			±150	ppm/°C
Ratio of Change in V <sub>Z</sub> to Change in I <sub>Z</sub>	$\frac{\Delta V_Z}{\Delta I_Z}$	I <sub>Z(min)</sub> ≤ I <sub>Z</sub> ≤ 1mA	T <sub>A</sub> = 25°C			2.0	mV
			T <sub>A</sub> = -40 to +85°C			2.5	mV
		1mA ≤ I <sub>Z</sub> ≤ 12mA	T <sub>A</sub> = 25°C			8.0	mV
			T <sub>A</sub> = -40 to +85°C			10.0	mV
Reverse Dynamic Impedance	Z <sub>R</sub>	I <sub>Z</sub> = 1mA, f = 120 Hz, I <sub>AC</sub> = 0.1 I <sub>Z</sub>			0.25	2.0	Ω
Wideband Noise (RMS)	e <sub>N</sub>	I <sub>Z</sub> = 100µA 10Hz ≤ f ≤ 10kHz			20		µV
Long Term Stability of Reverse Breakdown Voltage	ΔV <sub>Z</sub>	t = 1000 hours T = 25°C ± 0.1°C I <sub>Z</sub> = 100µA			120		ppm

PRELIMINARY - April 13, 1998

**OUTLINE DRAWING SOT-23-3L**

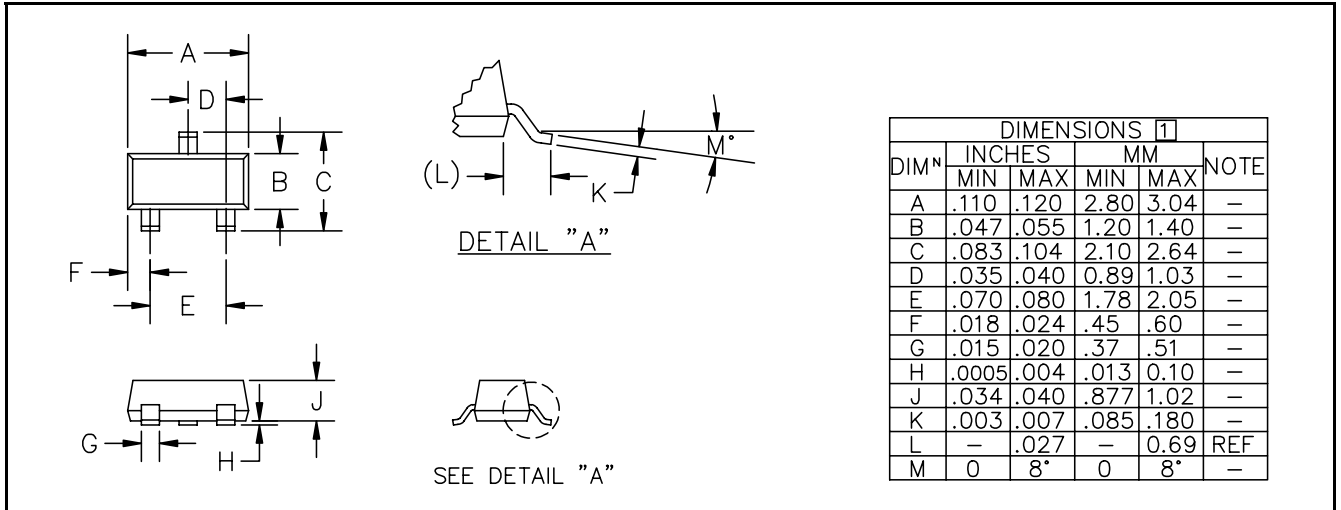

**LAND PATTERN SOT-23-3L**

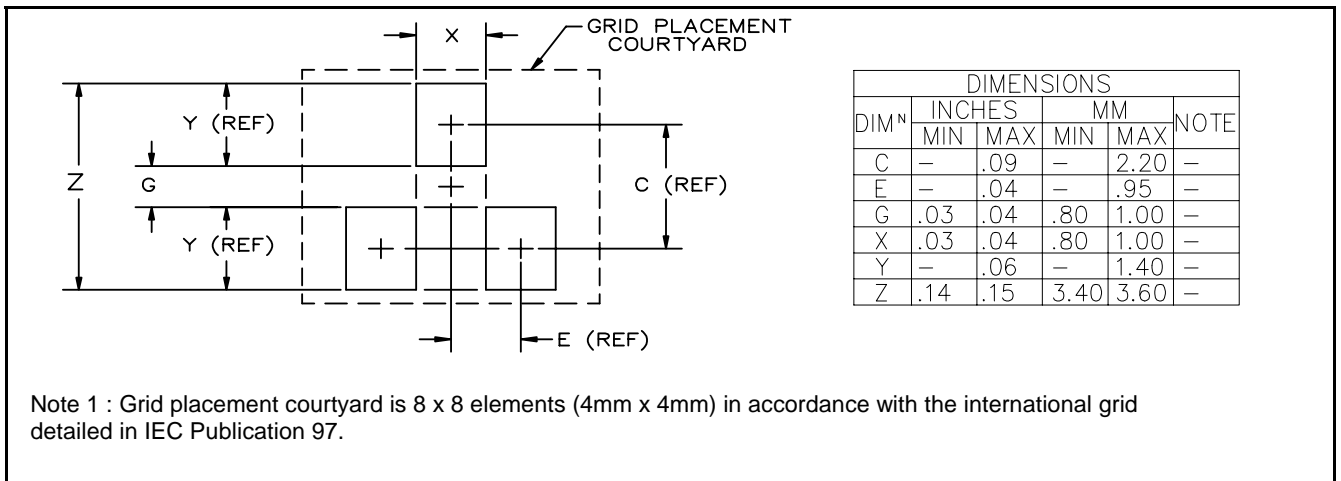

PRELIMINARY - April 13, 1998

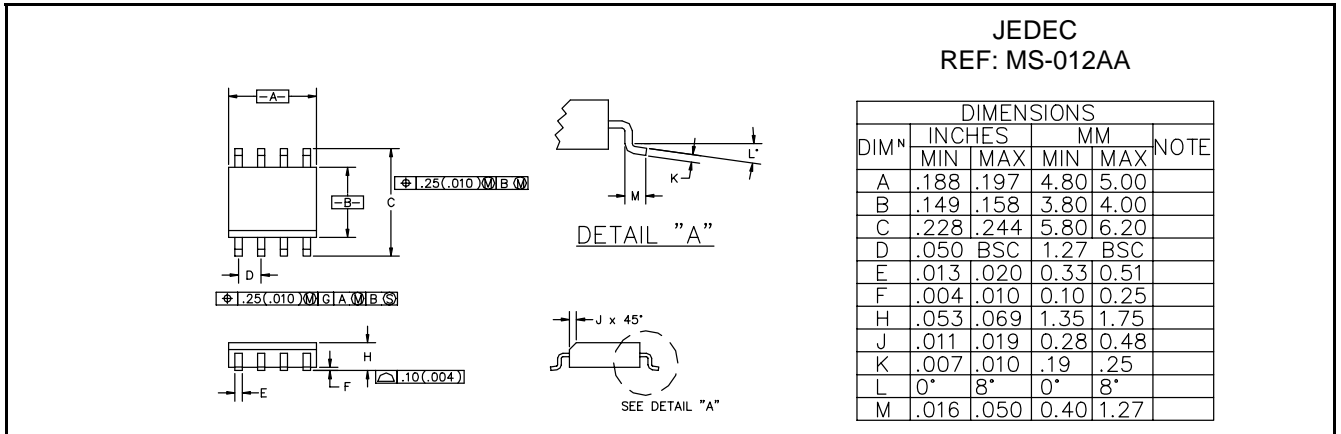
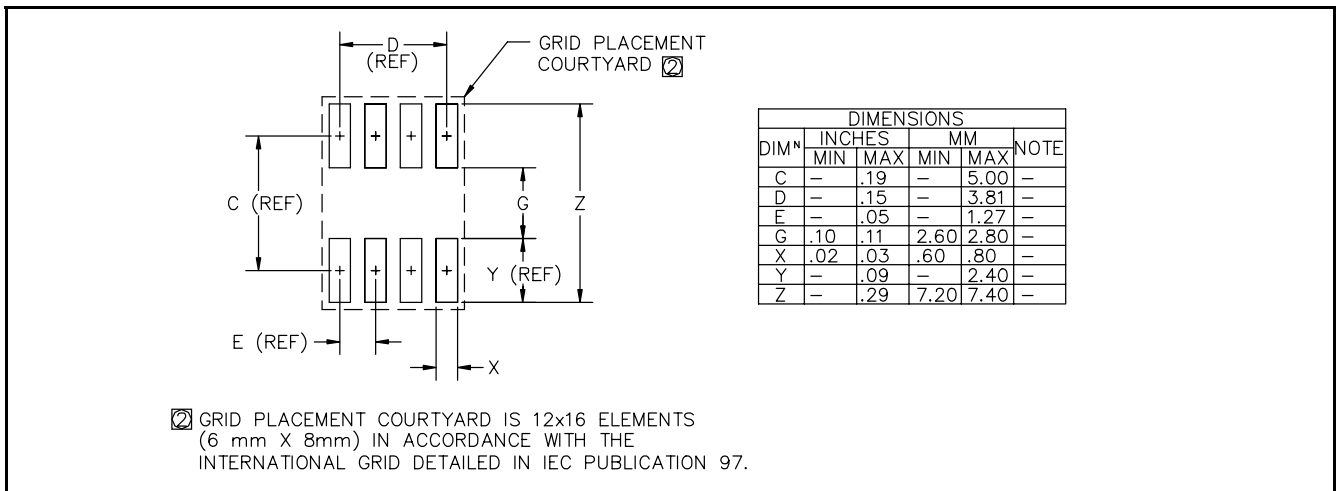
**OUTLINE DRAWING SO-8**

**LAND PATTERN SO-8**

**OUTLINE DRAWING TO-92**
