

April 13, 1998

 TEL:805-498-2111 FAX:805-498-3804 WEB:<http://www.semtech.com>

DESCRIPTION

The SC431 is a three terminal adjustable shunt regulator with thermal stability guaranteed over temperature. The output voltage can be adjusted to any value from 2.5V (V_{REF}) to 36V with two external resistors. The SC431 has a typical dynamic output impedance of 0.25Ω . Active output circuitry provides a very sharp turn on characteristic, making the SC431 an excellent replacement for zener diodes.

The SC431 shunt regulator is available in three voltage tolerances (0.5%, 1.0% and 2.0%) and three package options (SOT-23-3, SO-8 and TO-92). The three voltage tolerances allow the designer the opportunity to select the proper cost/tolerance for their application.

FEATURES

- Wide operating current range 100 μ A to 150mA
- Low dynamic output impedance 0.25Ω typ.
- Trimmed bandgap design $\pm 0.5\%$
- Alternate for TL431, LM431 & AS431

APPLICATIONS

- Linear Regulators
- Adjustable Supplies
- Switching Power Supplies
- Battery Operated Computers
- Instrumentation
- Computer Disk Drives

PIN CONFIGURATIONS

SOT-23 -3 Lead (Top View)

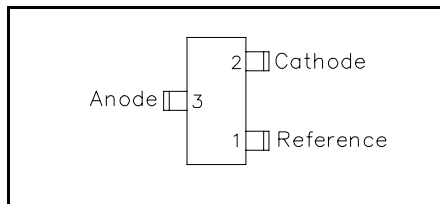

SOIC 8 Lead (Top View)

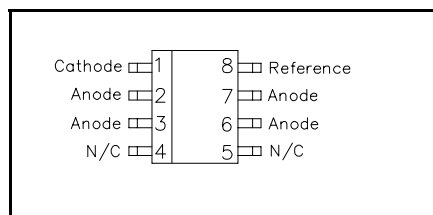

TO-92 (Top View)

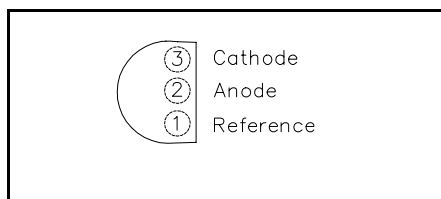

BLOCK DIAGRAM

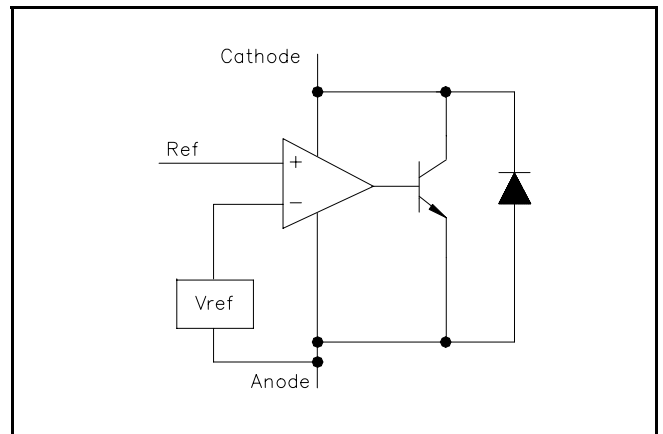

SYMBOL DIAGRAM

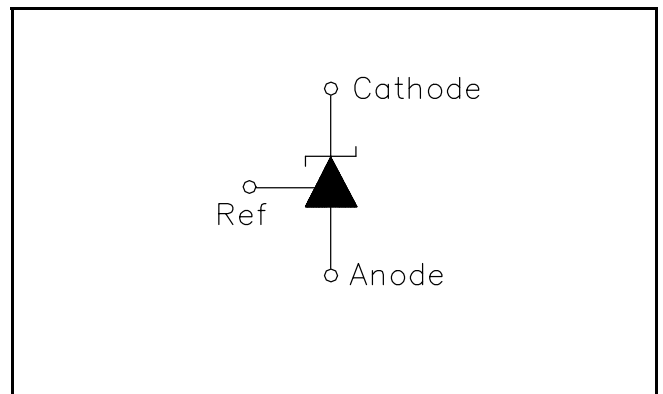

April 13, 1998

ABSOLUTE MAXIMUM RATINGS

Parameter	Symbol	Maximum	Units
Cathode Voltage	V_Z	37	V
Continuous Cathode Current	I_Z	150	mA
Reference Input Current	I_{REF}	10	mA
Operating Junction Temperature Range	T_J	-40 to +150	°C
Storage Temperature Range	T_{STG}	-65 to +150	°C
Thermal Resistance TO-92 SO-8 SOT-23	θ_{JA}	160 175 410	°C/W
Power Dissipation at $T_A = 25^\circ\text{C}$ TO-92 SO-8 SOT-23	P_D	0.78 0.71 0.30	W
Lead Temperature (Soldering) 10 seconds	T_{LEAD}	260	°C

ORDERING INFORMATION

PACKAGE	TOLERANCE			T/R Quantity
	0.5%	1.0%	2.0%	
SO-8 ⁽¹⁾	SC431CS - .5	SC431CS - 1	SC431CS - 2	2.5K
SOT-23 ⁽¹⁾	SC431CSK - .5	SC431CSK - 1	SC431CSK - 2	3K
TO-92 ⁽¹⁾⁽²⁾	SC431CZ - .5	SC431CZ - 1	SC431CZ - 2	TR=3K, TA=2K

Notes:

- (1) Add suffix 'TR' for Tape & Reel.
 (2) Add suffix 'TA' for Tape Ammo.

April 13, 1998

ELECTRICAL CHARACTERISTICS

 Unless specified, $T_A = 25^\circ\text{C}$

Parameter	Symbol	Condition	SC431 0.5%			SC431 1%			SC431 2%			UNITS
			MIN	TYP	MAX	MIN	TYP	MAX	MIN	TYP	MAX	
Reference Voltage	V_{REF}	$V_Z = V_{REF}$ $I_Z = 10\text{mA}$ (test circuit 1)	2.482	2.495	2.507	2.470	2.495	2.520	2.445	2.495	2.545	V
V_{REF} Temp Deviation	V_{DEV}	$T_A = -40$ to $+85^\circ\text{C}$, $V_Z = V_{REF}$ (test circuit 1) $I_Z = 10\text{mA}$		8	17		8	25		15	30	mV
Ratio of Change in V_{REF} to Change in Cathode Voltage	$\frac{\Delta V_{REF}}{\Delta V_Z}$	$I_Z = 10\text{mA}$, $\Delta V_Z = 10\text{V}$ to V_{REF}		-0.5	-2.7		-0.5	-2.7		-0.5	-2.7	mV/V
		$I_Z = 10\text{mA}$, $\Delta V_Z = 36\text{V}$ to 10V		-1.0	-2.0		-1.0	-2.0		-1.0	-2.0	
Reference Input Current	I_{REF}	$R1 = 10\text{k}\Omega$, $R2 = \infty$, $I_Z = 10\text{mA}$ (test circuit 2)		0.5	4		0.5	4		0.5	4	μA
I_{REF} Temp Deviation	$I_{REF(DEV)}$	$T_A = -40$ to $+85^\circ\text{C}$, $R1 = 10\text{k}\Omega$, $R2 = \infty$, $I_Z = 10\text{mA}$ (test circuit 2)		0.4	1.2		0.4	1.2		0.4	1.2	μA
Off State Cathode Current	$I_{Z(off)}$	$V_{REF} = 0\text{V}$, $V_Z = 36\text{V}$ (test circuit 3)		0.04	0.5		0.04	0.5		0.04	0.5	μA
Dynamic Output Impedance	r_z	$f < 1\text{kHz}$, $V_Z = V_{REF}$ $I_Z = 100\mu\text{A}$ to 100mA (test circuit 1)		0.25	0.5		0.25	0.5		0.25	0.5	Ω
Minimum Operating Current	$I_{Z(min)}$	$V_Z = V_{REF}$ (test circuit 1)			100			100			100	μA

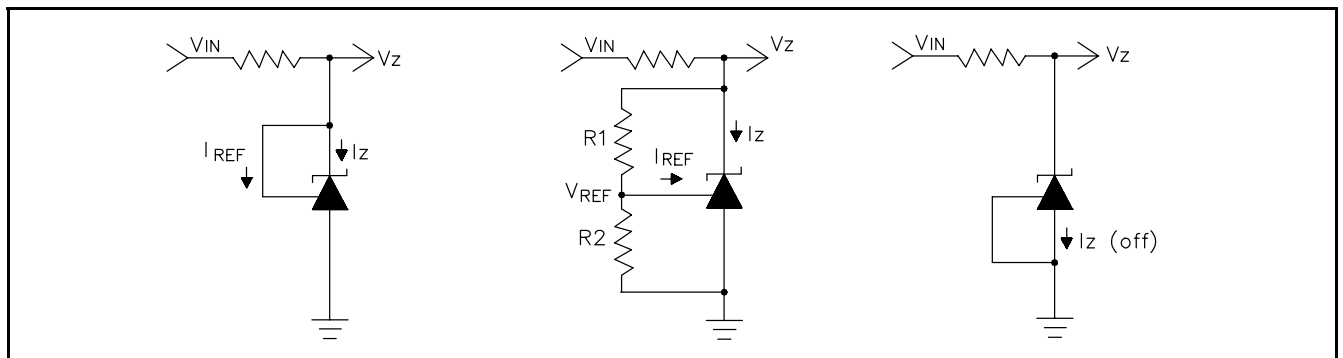
TEST CIRCUITS

Test Circuit 1:
 $V_Z = V_{REF}$
Test Circuit 2:
 $V_Z > V_{REF}$
Test Circuit 3:
 Off State Current

RECOMMENDED OPERATING CONDITIONS

	Min	Max	Symbol
Cathode Voltage, V_Z	V_{REF}	36	V
Cathode Current, I_Z	0.1	150	mA

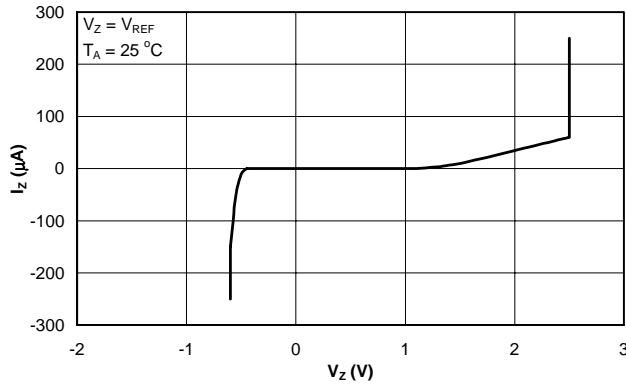
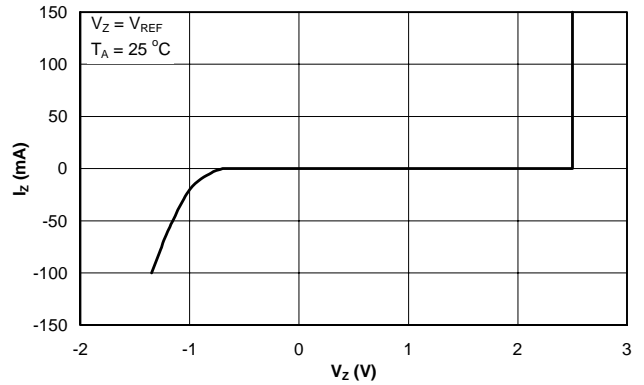
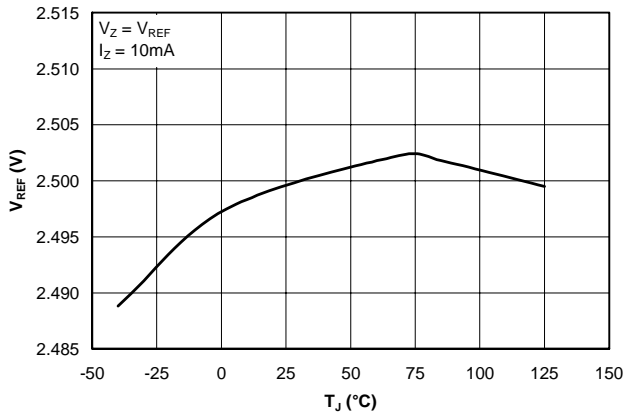
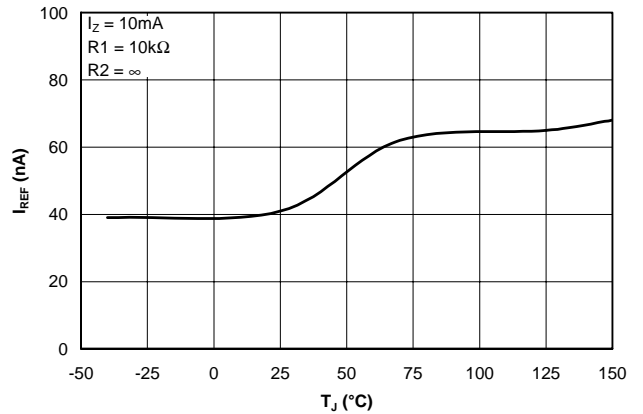
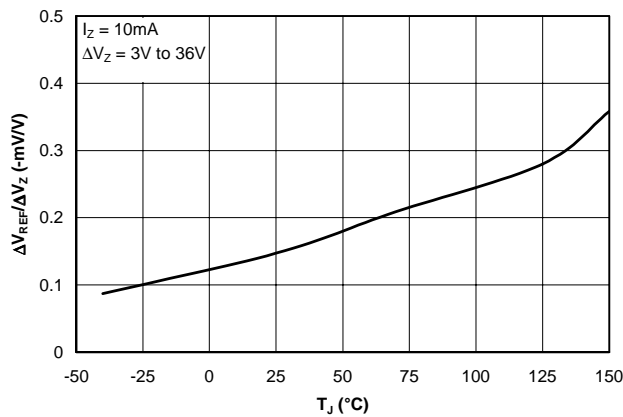
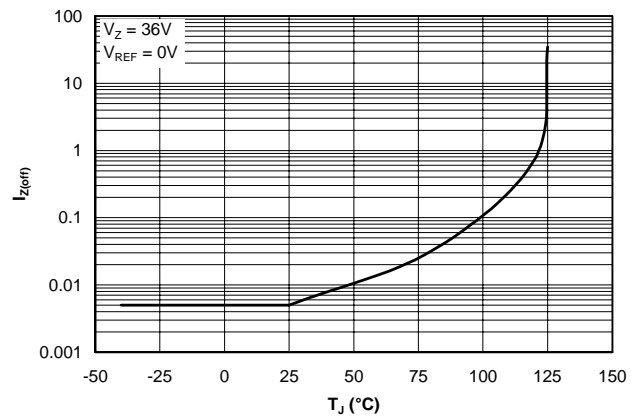
April 13, 1998

TYPICAL CHARACTERISTICS
Cathode Current vs. Cathode Voltage

Cathode Current vs. Cathode Voltage

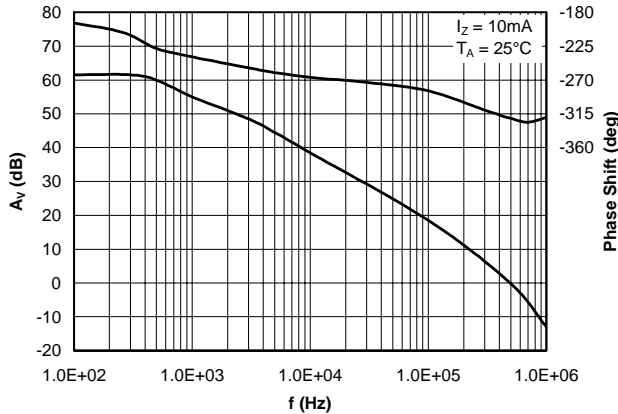
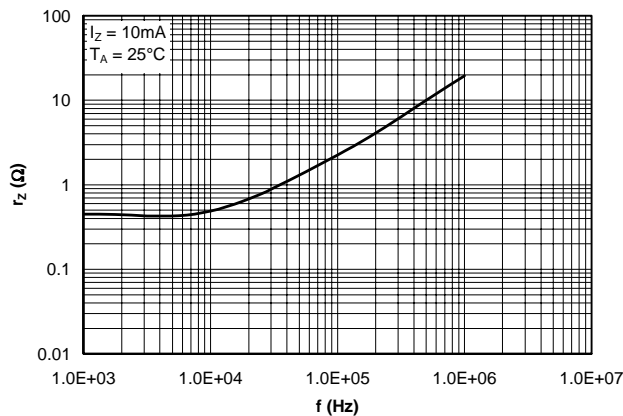
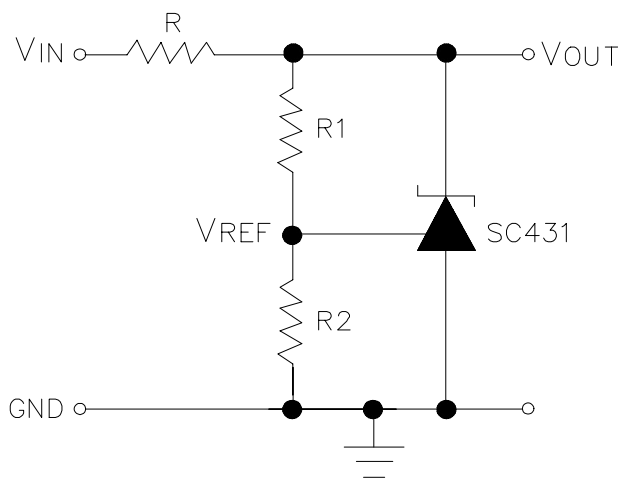
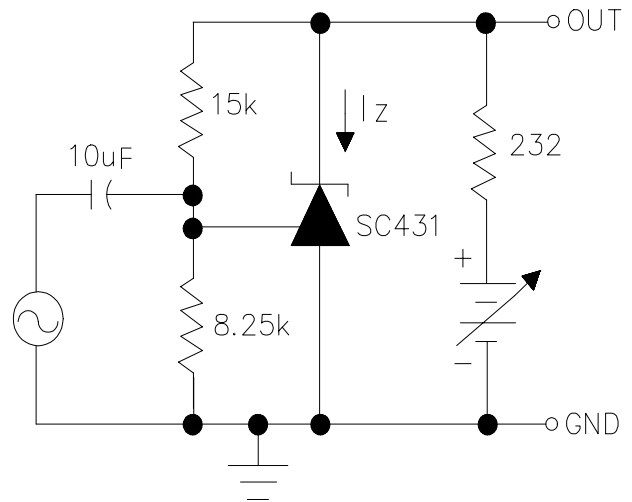
Reference Voltage vs. Junction Temperature

Reference Input Current vs. Junction Temperature

Ratio of Delta Reference Voltage to Delta Cathode Voltage vs. Junction Temperature

Off-State Cathode Current vs. Junction Temperature

April 13, 1998

TYPICAL CHARACTERISTICS (Cont.)
Small-Signal Gain and Phase Shift vs. Frequency

Reference Impedance vs. Frequency

APPLICATION CIRCUIT

Test Circuit For Small-Signal Gain and Phase Shift

Notes for Application Circuit:

 1) Set V_{OUT} according to the following equation:

$$V_{OUT} = V_{REF} \left(1 + \frac{R1}{R2} \right) + I_{REF} R1$$

2) Choose the value for R as follows:

- The maximum limit for R should be such that the cathode current, I_Z , is greater than the minimum operating current ($100\mu A$) at $V_{IN(min)}$.
- The minimum limit for R should be such that I_Z does not exceed 150mA under all load conditions, and the instantaneous turn-on value for I_Z does not exceed 200mA. Both of the following conditions must be met:

$$R_{min} \geq \frac{V_{IN(max)}}{200 \text{ mA}} \quad (\text{to limit instantaneous turn-on } I_Z)$$

$$R_{min} \geq \frac{V_{IN(max)} - V_{OUT}}{I_{OUT(min)} + 150 \text{ mA}} \quad (\text{to limit } I_Z \text{ under normal operating conditions})$$

April 13, 1998

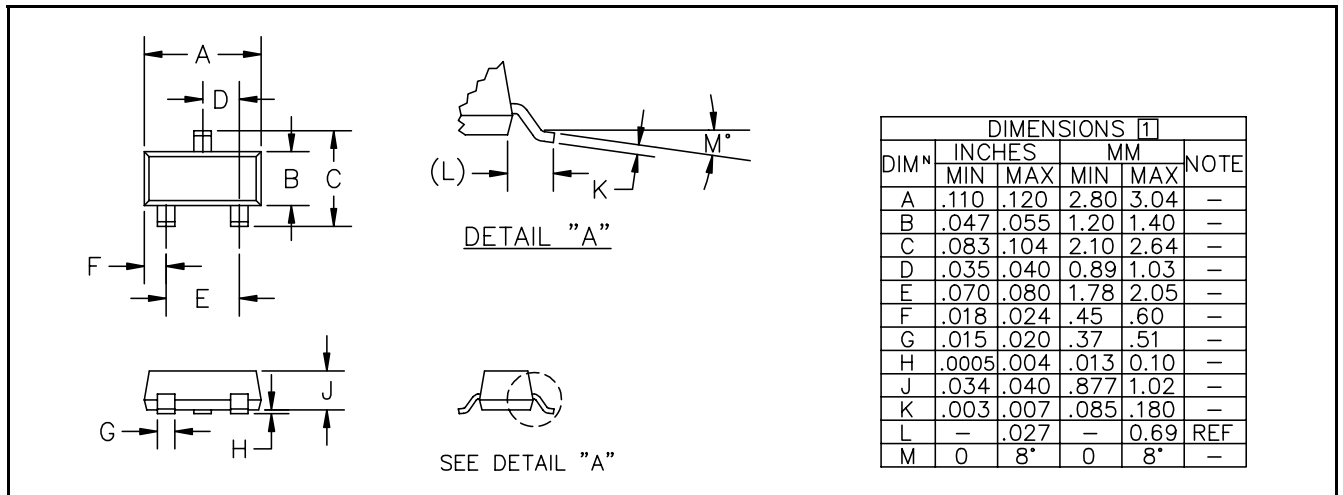
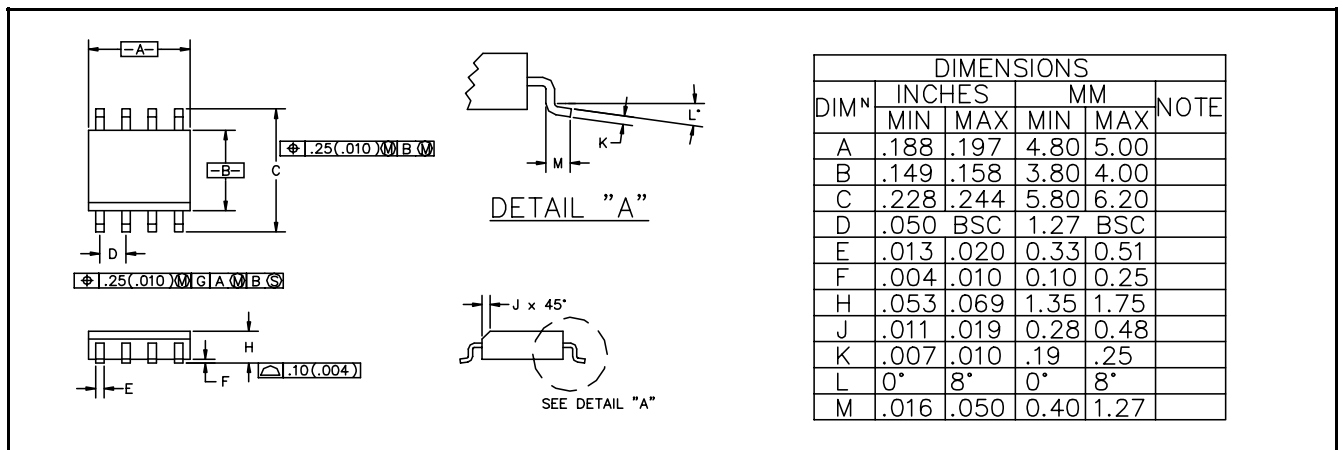
OUTLINE DRAWING SOT-23

OUTLINE DRAWING SO-8

OUTLINE DRAWING TO-92
