

# LT9526□ series

ø20mm, Dome Type, Colored Diffusion, High-luminosity, Large LED Lamps for Indoor Use

## Outline Dimensions

(Unit : mm)

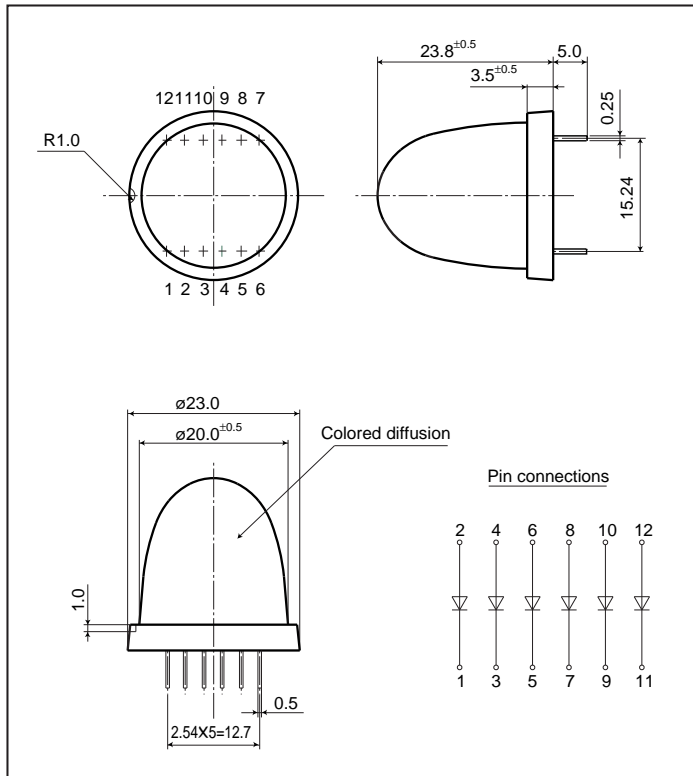

## Absolute Maximum Ratings

(Ta=25°C)

Model No.	Radiation color	Radiation material	Power dissipation P*1 (mW)	Forward current IF*2 (mA)	Peak forward current IFM*2*3 (mA)	Derating factor (mA/°C)*2		Reverse voltage VR*2 (V)	Operating temperature Topr (°C)	Storage temperature Tstg (°C)	Soldering temperature Tsol*4 (°C)
						DC	Pulse				
LT9526D	Red	GaAsP on GaP	1 010	60	100	1.09	1.82	5	-25 to +70	-30 to +80	260
LT9526H	Yellow	GaAsP on GaP	1 010	60	100	1.09	1.82	5	-25 to +70	-30 to +80	260
LT9526E	Yellow-green	GaP	1 010	60	100	1.09	1.82	5	-25 to +70	-30 to +80	260

\*1 Per chip

\*2 Per lamp(6 chips/lamp)

\*3 Duty ratio=1/10, Pulse width=0.1ms

\*4 5s(At the position of 1.6mm or more from the bottom face of resin package)

## Electro-optical Characteristics\*5

(Ta=25°C)

Lens type	Model No.	Forward voltage VF(V)		Peak emission wavelength λp(nm)		Luminous intensity Iv(mcd)		Spectrum radiation bandwidth Δλ(nm)		Reverse current IR(μA)		Terminal capacitance Ci(pF)		Page for characteristics diagrams
		TYP	MAX	TYP	IF (mA)	TYP	IF (mA)	TYP	IF (mA)	MAX	VR (V)	TYP	(MHz)	
Colored diffusion	LT9526D	2.0	2.8	635	40	250	40	35	40	10	4	30	1	→
	LT9526H	2.0	2.8	585	40	250	40	35	40	10	4	30	1	→
	LT9526E	2.2	2.8	565	40	250	40	30	40	10	4	30	1	→

\*5 Per chip

\*6 Luminous intensity per lamp at IF=40mA/chip(6 chips/lamp)

HD series

Forward Current Derating Curve

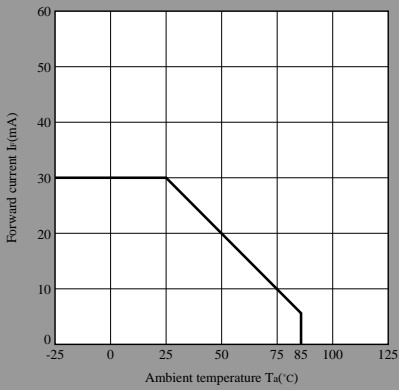

Forward Current vs. Forward Voltage(Note)

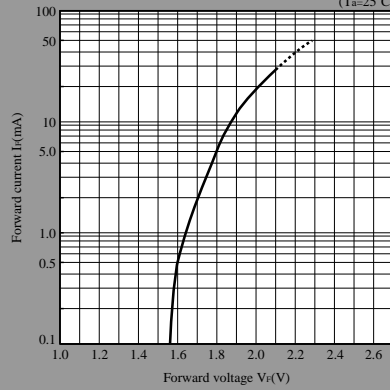

Luminous Intensity vs. Ambient Temperature(Note)

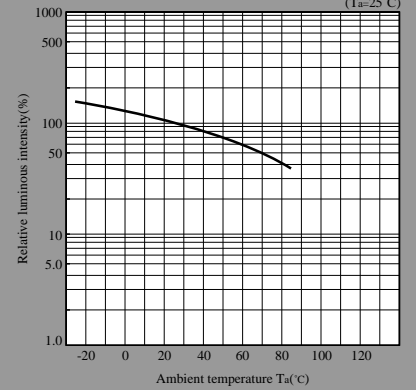

Peak Forward Current Derating Curve

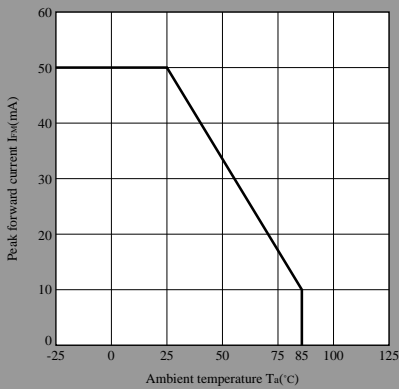

Luminous Intensity vs. Forward Current(Note)

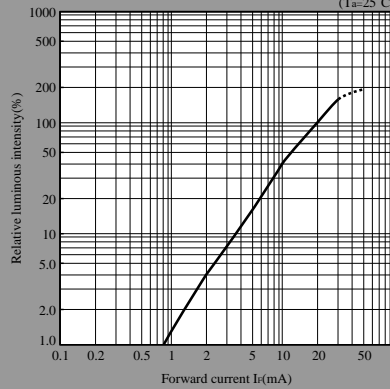

Duty Ratio vs. Peak Forward Current

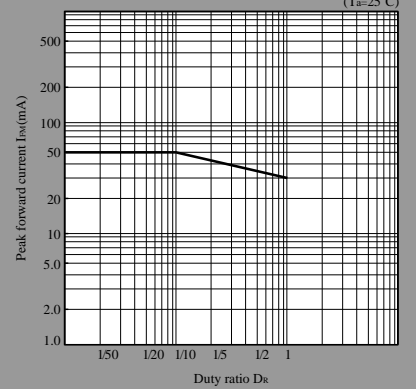

Note) Characteristics shown in diagrams are typical values. (not assurance value)

**HY series**

Forward Current Derating Curve

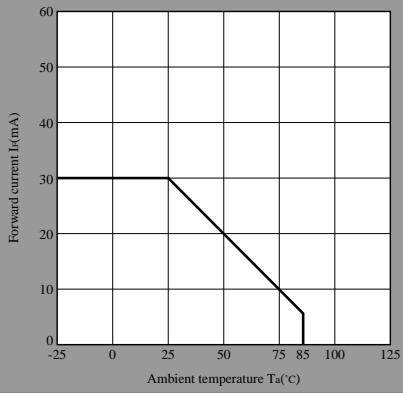

Forward Current vs. Forward Voltage(Note)

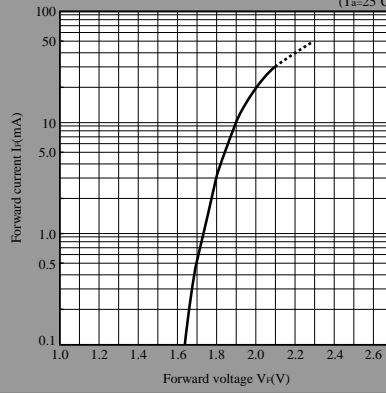

Luminous Intensity vs. Ambient Temperature(Note)

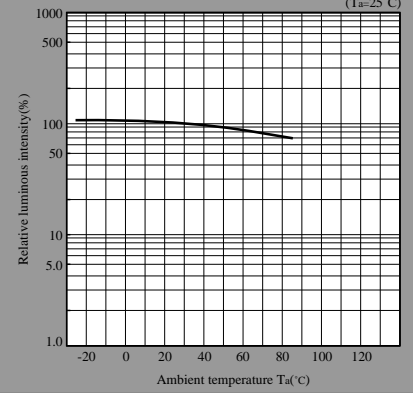

Peak Forward Current Derating Curve

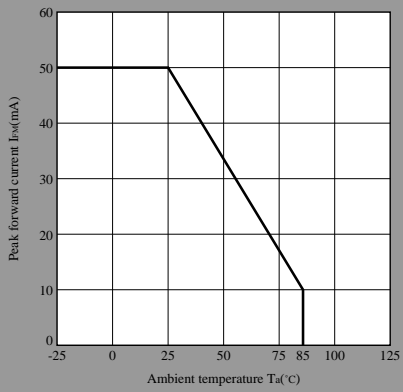

Luminous Intensity vs. Forward Current(Note)

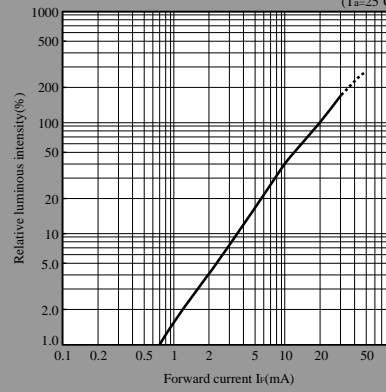

Duty Ratio vs. Peak Forward Current

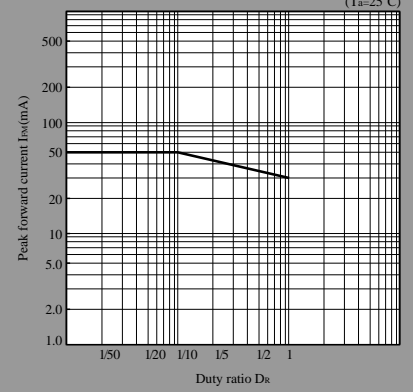

Note) Characteristics shown in diagrams are typical values. (not assurance value)

EG series

Forward Current Derating Curve

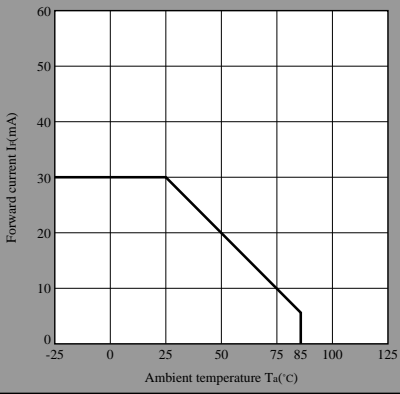

Forward Current vs. Forward Voltage(Note)

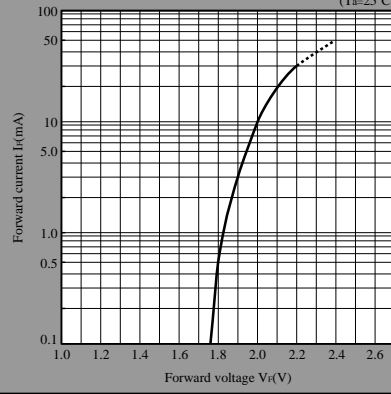

Luminous Intensity vs. Ambient Temperature(Note)

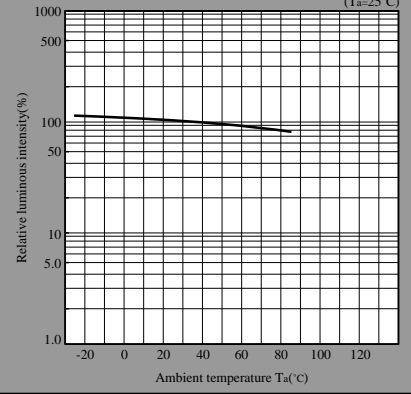

Peak Forward Current Derating Curve

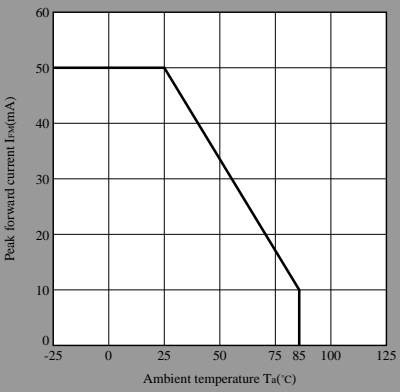

Luminous Intensity vs. Forward Current(Note)

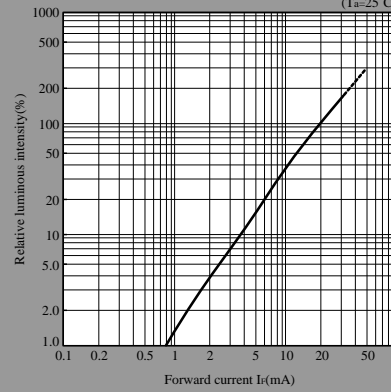

Duty Ratio vs. Peak Forward Current

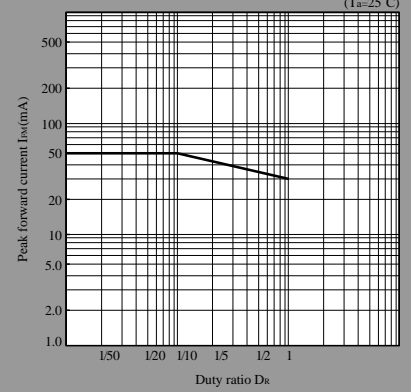

Note) Characteristics shown in diagrams are typical values. (not assurance value)