

PREPARED BY: <i>M. Mitsui Sep. 30, 1998</i>	DATE:	SHARP ELECTRONIC COMPONENTS GROUP SHARP CORPORATION SPECIFICATION	SPEC. No. ED-97123A
APPROVED BY: <i>J. Yoshikawa Sep 30 1998</i>	DATE:		ISSUE September 30, 1998
			PAGE 13 pages
		REPRESENTATIVE DIVISION OPTO-ELECTRONIC DEVICES DIV.	

DEVICE SPECIFICATION FOR
PHOTOCOUPLER

MODEL No. **PC3H7**

Business dealing name	
PC3H7	PC3H7AB
PC3H7A	PC3H7BC
PC3H7B	PC3H7CD
PC3H7C	PC3H7AC
PC3H7D	PC3H7BD
	PC3H7AD

- These specification sheets include materials protected under copyright of Sharp Corporation ("Sharp"). Please do not reproduce or cause anyone to reproduce them without Sharp's consent.
- When using this product, please observe the absolute maximum ratings and the instructions for use outlined in these specification sheets, as well as the precautions mentioned below. Sharp assumes no responsibility for any damage resulting from use of the product which does not comply with the absolute maximum ratings and the instructions included in these specification sheets, and the precautions mentioned below.

(Precautions)

 - This product is designed for use in the following application areas ;

• OA equipment	• Audio visual equipment	• Home appliances
• Telecommunication equipment (Terminal)	• Measuring equipment	
• Tooling machines	• Computers	

If the use of the product in the above application areas is for equipment listed in paragraphs (2) or (3), please be sure to observe the precautions given in those respective paragraphs.
 - Appropriate measures, such as fail-safe design and redundant design considering the safety design of the overall system and equipment, should be taken to ensure reliability and safety when this product is used for equipment which demands high reliability and safety in function and precision, such as ;

• Transportation control and safety equipment (aircraft, train, automobile etc.)		
• Traffic signals	• Gas leakage sensor breakers	• Rescue and security equipment
• Other safety equipment		
 - Please do not use this product for equipment which require extremely high reliability and safety in function and precision, such as ;

• Space equipment	• Telecommunication equipment (for trunk lines)
• Nuclear power control equipment	• Medical equipment
 - Please contact and consult with a Sharp sales representative if there are any questions regarding interpretation of the above three paragraphs.
- Please contact and consult with a Sharp sales representative for any questions about this product.

CUSTOMER'S APPROVAL

DATE _____

BY _____

DATE PRESENTED BY

T. Matsumura

T. Matsumura,
Department General Manager of
Engineering Dept.,II
Opto-Electronic Devices Div.
ELECOM Group
SHARP CORPORATION

1. Application

This specification applies to the outline and characteristics of photocoupler;
Model No. PC3H7.

2. Outline

Refer to the attached drawing No. CY8375K02.

3. Ratings and characteristics

Refer to the attached sheet, page 4 to 6.

4. Reliability

Refer to the attached sheet, page 7.

5. Incoming inspection

Refer to the attached sheet, page 8.

6. Supplement

6.1 Isolation voltage shall be measured in the following method.

- (1) Short between anode and cathode on the primary side and between collector and emitter on the secondary side.
- (2) The dielectric withstand tester with zero-cross circuit shall be used.
- (3) The wave form of applied voltage shall be a sine wave.

6.2 This product is not designed against irradiation.

This product is assembled with electrical input and output.

This product incorporates non-coherent light emitting diode.

6.3 Packaging specifications

Refer to the attached sheet, page 9 to 11.

6.4 Collector current (I_c) Delivery rank table

("○" mark indicates business dealing name of ordered product)

Ordered product	Business dealing name	Rank mark	I_c (mA)	Test conditions
	PC3H7	A, B, C, D or no mark	0.2 to 4.0	$I_F=1\text{mA}$ $V_{CE}=5\text{V}$ $T_a=25^\circ\text{C}$
	PC3H7A	A	0.35 to 0.7	
	PC3H7B	B	0.5 to 1.0	
	PC3H7C	C	0.8 to 1.6	
	PC3H7D	D	1.2 to 2.4	
	PC3H7AB	A or B	0.35 to 1.0	
	PC3H7BC	B or C	0.5 to 1.6	
	PC3H7CD	C or D	0.8 to 2.4	
	PC3H7AC	A, B or C	0.35 to 1.6	
	PC3H7BD	B, C or D	0.5 to 2.4	
	PC3H7AD	A, B, C or D	0.35 to 2.4	

6.5 ODS materials

This product shall not contain the following materials.

Also, the following materials shall not be used in the production process for this product.

Materials for ODS : CFC_s, Halon, Carbon tetrachloride,

1.1.1-Trichloroethane (Methylchloroform)

6.6 Brominated flame retardants

Specific brominated flame retardants such as the PBBO_s and PBB_s are not used in this device at all.

7. Notes

Refer to the attached sheet-1-1, 2.

2. Outline

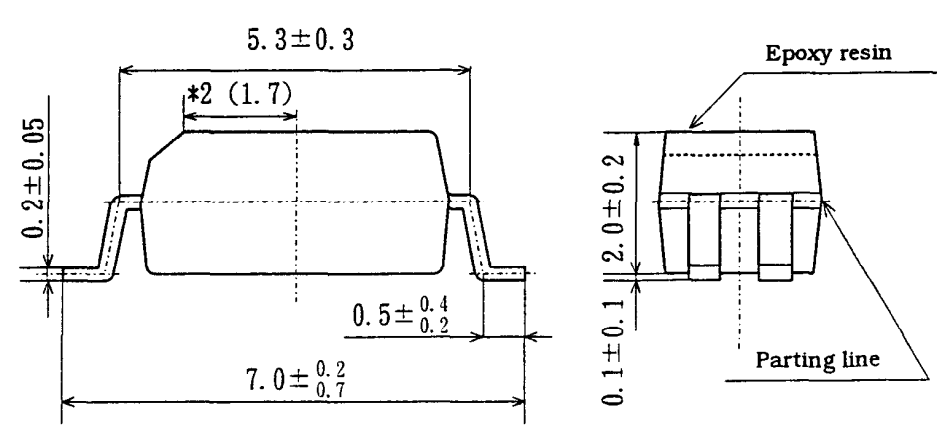
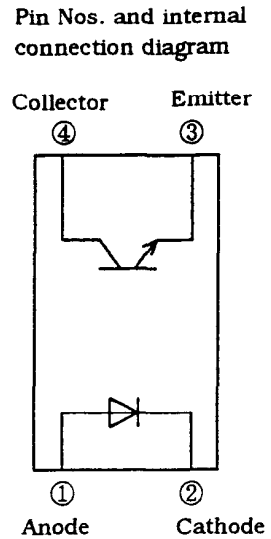
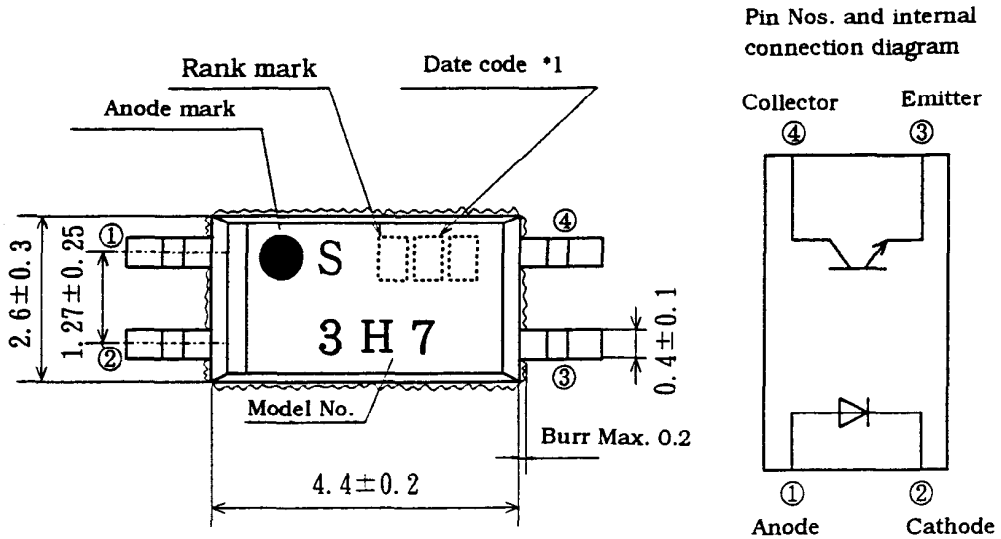

Product mass : Approx. 0.05g

- *1) 2-digit number shall be marked according to DIN standard.
- *2) Dimensions in parenthesis are shown for reference.
- *3) Marking is laser marking

UNIT : 1/1 mm	
Name	PC3H7 Outline Dimensions (Business dealing name : PC3H7)
Drawing No.	CY8375K02

3. Ratings and characteristics

3.1 Absolute maximum ratings

Ta=25°C

Parameter		Symbol	Rating	Unit
Input	*1 Forward current	I_F	50	mA
	*2 Peak forward current	I_{FM}	1	A
	Reverse voltage	V_R	6	V
	*1 Power dissipation	P	70	mW
Output	Collector-emitter voltage	V_{CEO}	70	V
	Emitter-collector voltage	V_{ECO}	6	V
	Collector current	I_C	50	mA
	*1 Collector power dissipation	P_C	150	mW
*1 Total power dissipation		P_{tot}	170	mW
Operating temperature		T_{opr}	-30 to +100	°C
Storage temperature		T_{stg}	-40 to +125	°C
*3 Isolation voltage		V_{iso}	2.5	kVrms
*4 Soldering temperature		T_{sol}	260	°C

*1 The derating factors of absolute maximum ratings due to ambient temperature are shown in Fig. 1 to 4.

*2 Pulse width $\leq 100 \mu s$, Duty ratio : 0.001 (Refer to Fig. 5)

*3 AC for 1 min, 40 to 60%RH, f=60Hz

*4 For 10 s

3.2 Electro-optical characteristics

Ta=25°C

Parameter		Symbol	Conditions	MIN.	TYP.	MAX.	Unit
Input	Forward voltage	V_F	$I_F=20\text{mA}$	-	1.2	1.4	V
	Reverse current	I_R	$V_R=4\text{V}$	-	-	10	μA
	Terminal capacitance	C_t	$V=0, f=1\text{kHz}$	-	30	250	pF
Output	Dark current	I_{CEO}	$V_{CE}=50\text{V}, I_F=0$	-	-	100	nA
	Collector-emitter breakdown voltage	BV_{CEO}	$I_c=0.1\text{mA}$ $I_F=0$	70	-	-	V
	Emitter-collector breakdown voltage	BV_{ECO}	$I_E=10\mu\text{A}, I_F=0$	6	-	-	V
Transfer characteristics	Collector current	I_c	$I_F=1\text{mA}, V_{CE}=5\text{V}$	0.2	-	4	mA
	Collector-emitter saturation voltage	$V_{CE(sat)}$	$I_F=20\text{mA}$ $I_c=1\text{mA}$	-	0.1	0.2	V
	Isolation resistance	Riso	DC500V 40 to 60%RH	5×10^{10}	10^{11}	-	Ω
	Floating capacitance	C_f	$V=0, f=1\text{MHz}$	-	0.6	1.0	pF
	Response time (Rise)	t_r	$V_{CE}=2\text{V}$ $I_c=2\text{mA}$	-	4	18	μs
	Response time (Fall)	t_f	$R_L=100\Omega$	-	3	18	μs

(Fig. 1) Forward current vs. ambient temperature

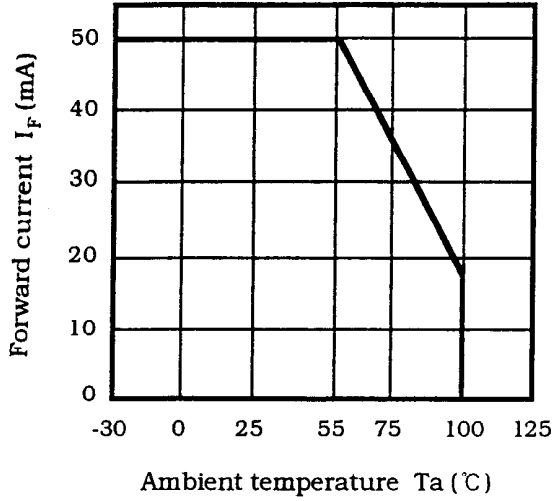

(Fig. 2) Diode power dissipation vs. ambient temperature

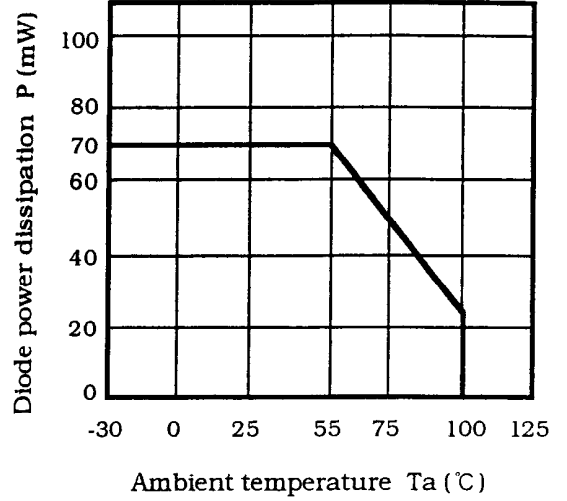

(Fig. 3) Collector power dissipation vs. ambient temperature

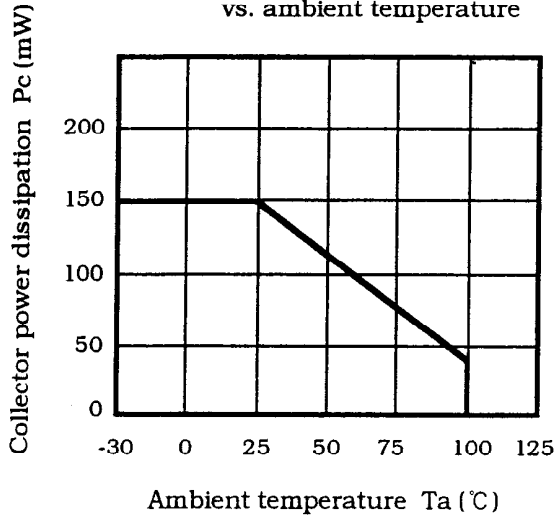

(Fig. 4) Total power dissipation vs. ambient temperature

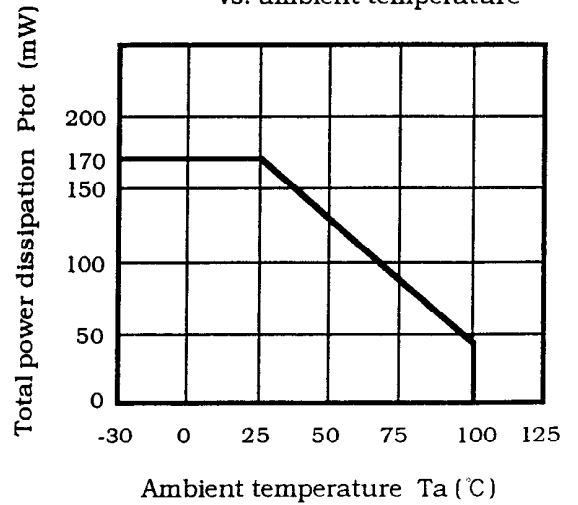

(Fig. 5) Peak forward current vs. duty ratio

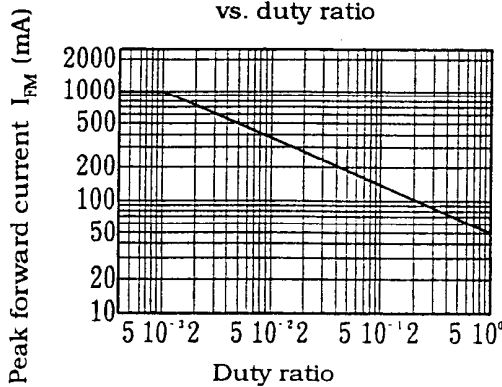

Pulse width ≤ 100 μs
Ta = 25°C

4. Reliability

The reliability of products shall satisfy items listed below.

Confidence level : 90%
LTPD : 10%/20%

Test Items	Test Conditions *1	Failure Judgement Criteria	Samples (n)
			Defective(C)
Solderability *2	230°C, 5 s	—	n=11, C=0
Soldering heat *3	260°C, 10 s	$V_F > U \times 1.2$	n=11, C=0
Terminal strength (Bending) *4	Weight : 1N 1 time/each terminal	$I_R > U \times 2$	n=11, C=0
Mechanical shock	15000m/s ² , 0.5ms 3 times/ ±X, ±Y, ±Z direction	$I_{CEO} > U \times 2$ $I_C < L \times 0.7$	n=11, C=0
Variable frequency vibration	100 to 2000 to 100Hz/4min 200m/s ² 4 times/ X, Y, Z direction	$V_{CE(sat)} > U \times 1.2$	n=11, C=0
Temperature cycling	1 cycle -40°C to +125°C (30min) (30min) 20 cycles test	U : Upper specification limit L : Lower specification limit	n=22, C=0
High temp. and high humidity storage	+85°C, 85%RH, 500h		n=22, C=0
High temp. storage	+125°C, 1000h		n=22, C=0
Low temp. storage	-40°C, 1000h		n=22, C=0
Operation life	$I_F = 50mA$, $P_{tot} = 170mW$ $T_a = 25°C$, 1000h		n=22, C=0

*1 Test method, conforms to JIS C 7021.

*2 Solder shall adhere at the area of 95% or more of immersed portion of lead, and pin hole or other holes shall not be concentrated on one portion.

*3 The lead pin depth dipped into solder shall be 0.2mm away from the root of lead pins.

*4 Terminal bending direction is shown below.

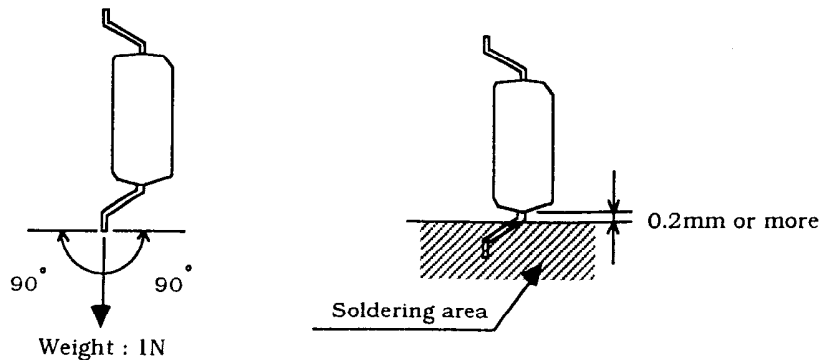

5. Incoming inspection

5.1 Inspection items

(1) Electrical characteristics

 $V_F, I_R, I_{CEO}, V_{CE(sat)}, I_C, R_{iso}, V_{iso}$

(2) Appearance

5.2 Sampling method and Inspection level

A single sampling plan, normal inspection level II based on ISO 2859 is applied. The AQL according to the inspection items are shown below.

Defect	Inspection item	AQL (%)
Major defect	Electrical characteristics Unreadable marking	0.1
Minor defect	Appearance defect except the above mentioned.	0.4

6.3 Package specifications

6.3.1 Taping conditions

- (1) Tape structure and Dimensions (Refer to the attached sheet, Page 10)

The tape shall have a structure in which a cover tape is sealed heat-pressed on the carrier tape.

- (2) Reel structure and Dimensions (Refer to the attached sheet, Page 11)

The taping reel shall be of plastic with its dimensions as shown in the attached drawing.

- (3) Direction of product insertion (Refer to the attached sheet, Page 11)

Product direction in carrier tape shall direct to the anode mark at the hole side on the tape.

- (4) Joint of tape

The cover tape and carrier tape in one reel shall be jointless.

- (5) The way to repair taped failure devices

The way to repair taped failure devices cut a bottom of carrier tape with a cutter, and after replacing to good devices, the cut portion shall be sealed with adhesive tape.

6.3.2 Adhesiveness of cover tape

- The exfoliation force between carrier tape and cover tape shall be 0.2N to 0.7N for the angle from 160° to 180°.

6.3.3 Rolling method and quantity

- Wind the tape back on the reel so that the cover tape will be outside the tape. Attach more than 20cm of blank tape to the trailer and the leader of the tape and fix the both ends with adhesive tape. One reel shall contain 3000pcs.

6.3.4 Marking

- The outer packaging case shall be marked with following information.
 - * Model No.
 - * Number of pieces delivered
 - * Production date

6.3.5 Storage condition

- Taped products shall be stored at the temperature 5 to 30°C and the humidities lower than 70%RH.

6.3.6 Safety protection during shipping

- There shall be no deformation of component or degradation of electrical characteristics due to shipping.

Carrier tape structure and Dimensions

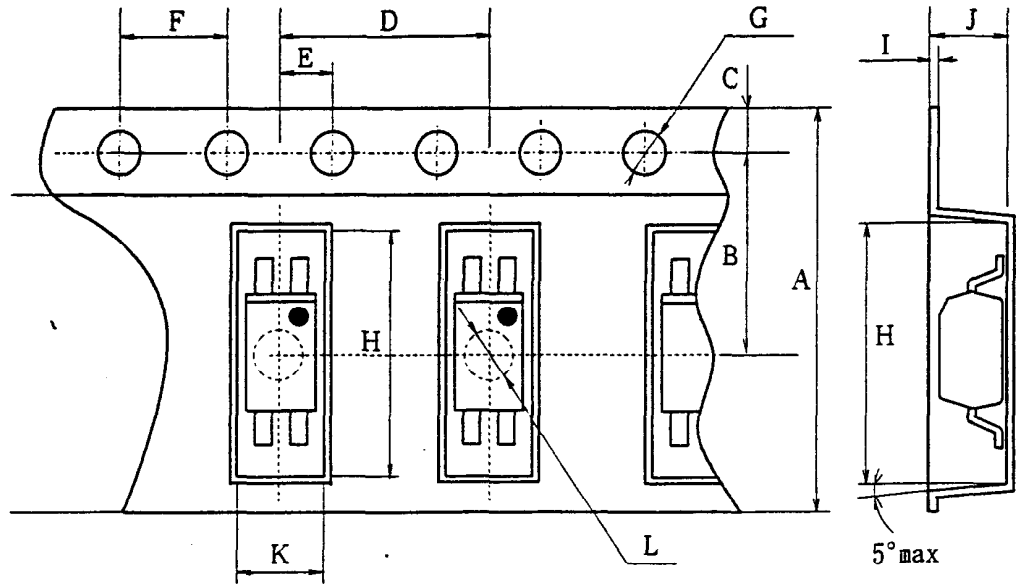

Symbol	A	B	C	D	E	F
Unit						
mm	± 0.3 12.0	± 0.1 5.5	± 0.1 1.75	± 0.1 8.0	± 0.1 2.0	± 0.1 4.0

Symbol	G	H	I	J	K	L
Unit						
mm	$\begin{matrix} +0.1 \\ -0.0 \end{matrix}$ ϕ 1.5	± 0.1 7.5	± 0.05 0.3	± 0.1 2.3	± 0.1 3.1	$\begin{matrix} +0.1 \\ -0.0 \end{matrix}$ ϕ 1.6

Reel structure and Dimensions

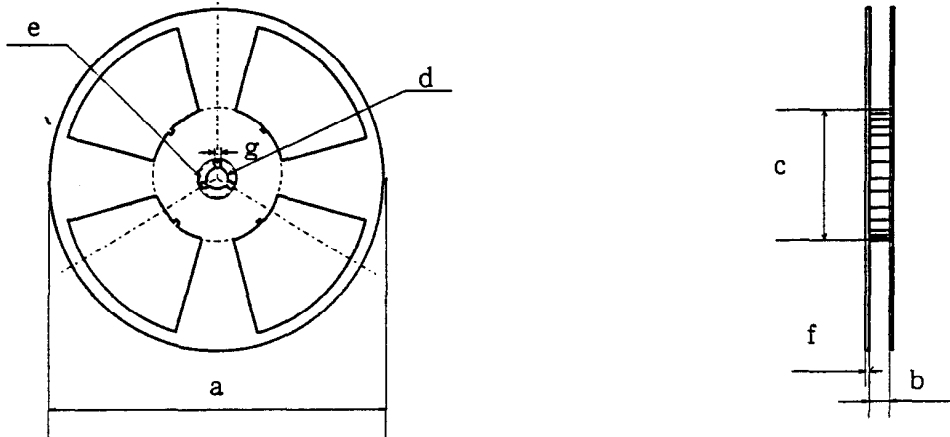

Symbol Unit	Check word						
	a	b	c	d	e	f	g
mm	330	13.5±1.5	100±1	13±0.5	23±1	2.0±0.5	2.0±0.5

Direction of product insertion

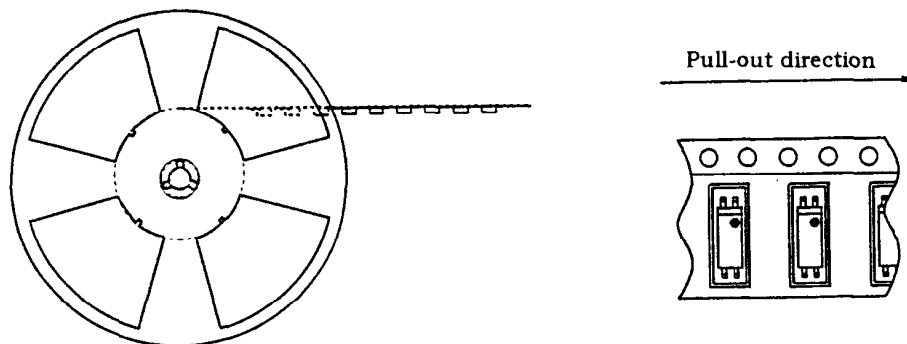

Precautions for Photocouplers

1 For cleaning

- (1) Solvent cleaning : Solvent temperature 45°C or less
Immersion for 3 min or less
- (2) Ultrasonic cleaning : The effect to device by ultrasonic cleaning differs by cleaning bath size, ultrasonic power output, cleaning time, PWB size or device mounting condition etc. Please test it in actual using condition and confirm that doesn't occur any defect before starting the ultrasonic cleaning.
- (3) Applicable solvent : Ethyl alcohol, Methyl alcohol, Isopropyl alcohol

In case when the other solvent is used, there are cases that the packaging resin is eroded. Please use the other solvent after thorough confirmation is performed in actual using condition.

2. The LED used in the Photocoupler generally decreases the light emission power by operation. In case of long operation time, please design the circuit with considering the degradation of the light emission power of the LED. (50%/5years)

3. Precautions for Soldering Photocouplers

(1) If solder reflow :

It is recommended that only one soldering be done at the temperature and the time within the temperature profile as shown in the figure below.

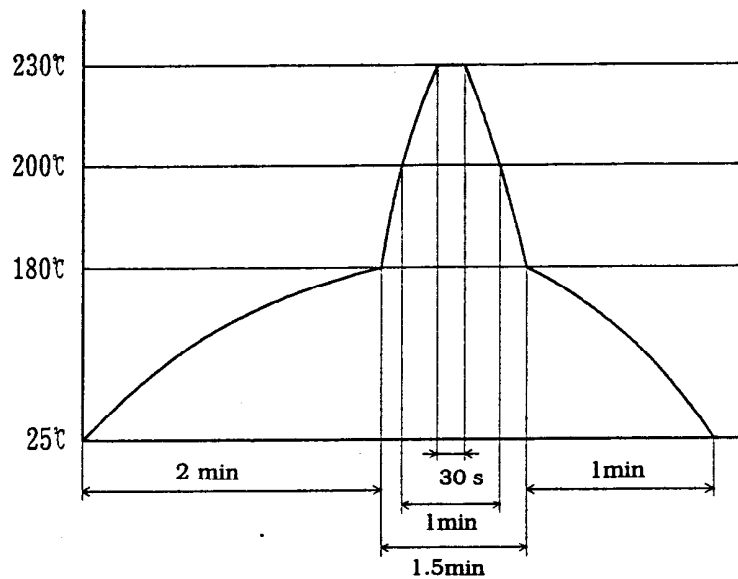

Since, influence to the device is different according to reflow equipment and its condition, please use the device after confirming no damage in the actual using condition.

(2) Other precautions

An infrared lamp used to heat up for soldering may cause a localized temperature rise in the resin. So keep the package temperature within that specified in Item (1). Also avoid immersing the resin part in the solder.