

FEATURES

- Pin-Compatible and Functionally Upwards-Compatible with Sharp LH5420 and LH543601, but Deeper
- **Expanded Control Register that is Fully Readable** as well as Writeable
- Fast Cycle Times: 18/20/25/30/35 ns
- **Improved Input Setup and Flag Out Timing**
- Two **512 × 36-bit** FIFO Buffers (LH543611) or Two **1024 × 36-bit** FIFO Buffers (LH543621)
- Full 36-bit Word Width
- Selectable 36/18/9-bit Word Width on Port B; **Selection May be Changed Without Resetting the BiFIFO**
- **Programmable Byte-Order Reversal – ‘Big-Endian ↔ Little-Endian Conversion’**
- Independently-Synchronized (‘Fully-Asynchronous’) Operation of Port A and Port B
- ‘Synchronous’ Enable-Plus-Clock Control at Both Ports
- R/W, Enable, Request, and Address Control Inputs are Sampled on the Rising Clock Edge
- Synchronous Request/Acknowledge ‘Handshake’ Capability; Use is Optional
- Device Comes Up Into a Known Default State at Reset; Programming is Allowed, but is not Required
- Asynchronous Output Enables
- Five Status Flags per Port: Full, Almost-Full, Half-Full, Almost-Empty, and Empty
- **All Flags are Independently Programmable for Either Synchronous or Asynchronous Operation**
- Almost-Full Flag and Almost-Empty Flag Have Programmable Offsets
- Mailbox Registers with Synchronized Flags
- Data-Bypass Function
- Data-Retransmit Function
- Automatic Byte Parity Checking **with Programmable Parity Flag Latch**
- **Programmable Byte Parity Generation**
- **Programmable Byte, Half-Word, or Full-Word Oriented Parity Operations**
- 8 mA-I_{OL} High-Drive Three-State Outputs with Built-In Series Resistor
- TTL/CMOS-Compatible I/O
- Space-Saving PQFP and TQFP Packages

FUNCTIONAL DESCRIPTION

The LH543611 and LH543621 contain two FIFO buffers, FIFO #1 and FIFO #2. These operate in parallel, but in opposite directions, for bidirectional data buffering. FIFO #1 and FIFO #2 each are organized as 512 or 1024 by 36 bits. The LH543611 and LH543621 are ideal either for wide unidirectional applications or for bidirectional data applications; component count and board area are reduced.

The LH543611 and LH543621 have two 36-bit ports, Port A and Port B. Each port has its own port-synchronous clock, but the two ports may operate asynchronously relative to each other. Data flow is initiated at a port by the rising edge of the appropriate clock; it is gated by the corresponding edge-sampled enable, request, and read/write control signals. At the maximum operating frequency, the clock duty cycle may vary from 40% to 60%. At lower frequencies, the clock waveform may be quite asymmetric, as long as the minimum pulse-width conditions for clock-HIGH and clock-LOW remain satisfied; the LH543611 and LH543621 are fully-static parts.

Conceptually, the port clocks CK_A and CK_B are free-running, periodic ‘clock’ waveforms, used to control other signals which are edge-sensitive. However, there actually is not any absolute requirement that these ‘clock’ waveforms must be periodic. An ‘asynchronous’ mode of operation is possible, in one or both directions, independently, if the appropriate enable and request inputs are continuously asserted, and enough aperiodic ‘clock’ pulses of suitable duration are generated by external logic to cause all necessary actions to occur.

A synchronous request/acknowledge handshake facility is provided at each port for FIFO data access. This request/acknowledge handshake resolves FIFO full and empty boundary conditions, when the two ports are operated asynchronously relative to each other.

FIFO status flags monitor the extent to which each FIFO buffer has been filled. Full, Almost-Full, Half-Full, Almost-Empty, and Empty flags are included for *each* FIFO. Each of these flags may be independently programmed for either synchronous or asynchronous operation. Also, the Almost-Full and Almost-Empty flags are programmable over the entire FIFO depth, but are automatically initialized to eight locations from the respective FIFO boundaries at reset. A data block of 512 (LH543611) or 1024 (LH543621) or fewer words may be retransmitted any desired number of times.

BOLD = Additions over the 5420/3601 feature set

Two mailbox registers provide a separate path for passing control words or status words between ports. Each mailbox has a New-Mail-Alert Flag, which is synchronized to the reading port's clock. This mailbox function facilitates the synchronization of data transfers between asynchronous systems.

Data-bypass mode allows Port A to directly transfer data to or from Port B at reset. In this mode, the device acts as a registered transceiver under the control of Port A. For instance, a master processor on Port A can use the data bypass feature to send or receive initialization or configuration information directly, to or from a peripheral device on Port B, during system startup.

A word-width-select option is provided on Port B for 36-bit, 18-bit, or 9-bit data access. This feature allows word-width matching between Port A and Port B, with no additional logic needed. It also ensures maximum utilization of bus band widths. Subject to meeting timing requirements, the word-width selection may be changed at any time during the operation of an LH543611 or LH543621, without the need either for a reset operation or for passing dummy words through Port B immediately after the

change; except that if the change is not made at a full-word boundary, at least one dummy word must be passed through Port B before any actual data words are transmitted.

A Byte Parity Check Flag at each port monitors data integrity. Control-Register bit 00 (zero) selects the parity mode, odd or even. This bit is initialized for odd data parity at reset; but it may be reprogrammed for even parity, or back again to odd parity, as desired. The parity flags may be programmed to operate either in a latched mode or in a flowthrough mode. The parity checking may be performed over 36-bit full-words, over 18-bit half-words, or over 9-bit single bytes.

Parity generation may be selected as well as parity checking, and may likewise be performed over full-words or half-words or single bytes. In any case, a parity bit of the proper mode is generated over the least-significant eight bits of a byte, and then is stored in the most-significant bit position of the byte as it passes through the LH543611/21, overwriting whatever bit was present in that bit position previously.

PIN CONNECTIONS

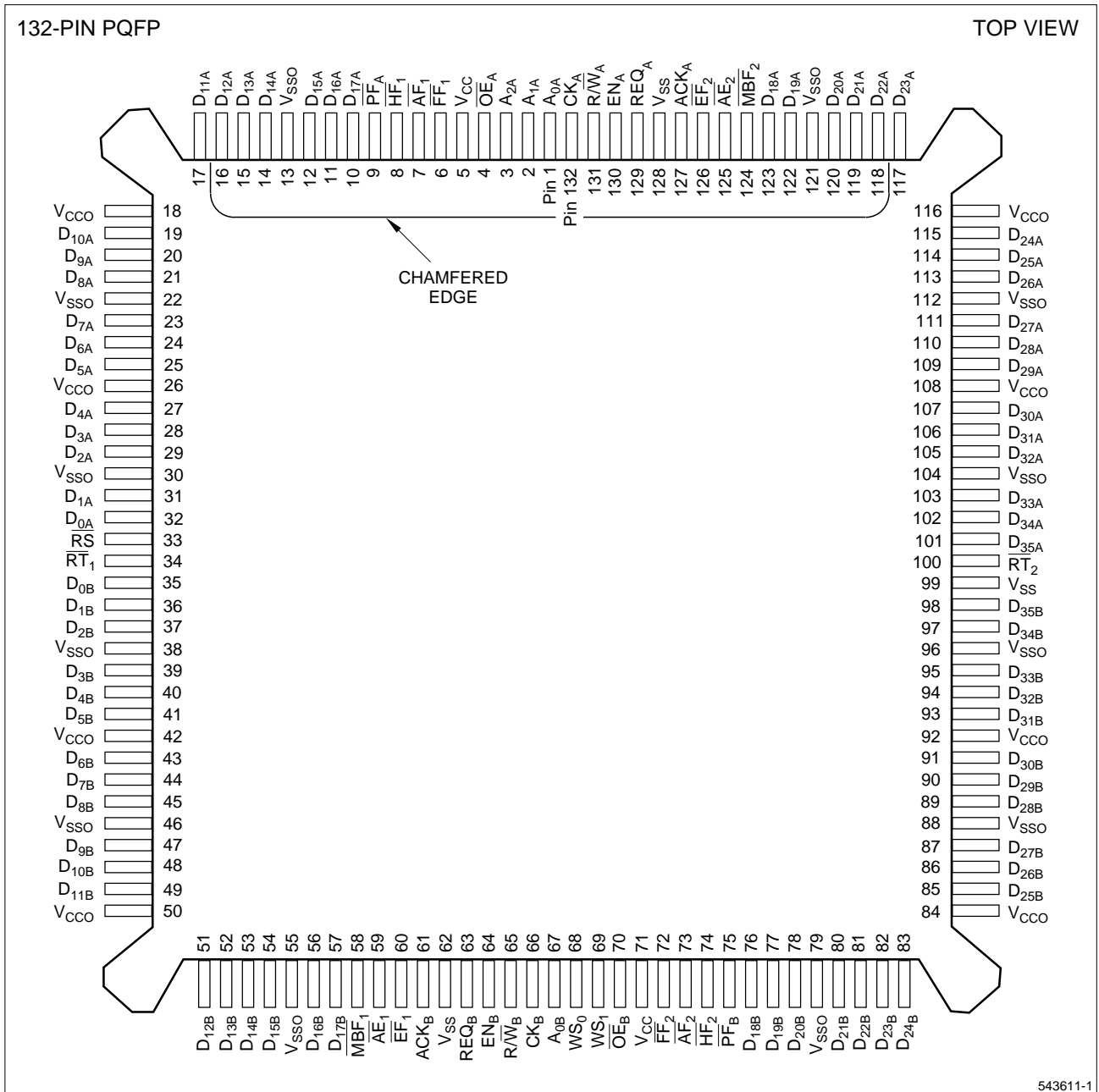

543611-1

Figure 1. Pin Connections for 132-Pin PQFP Package (Top View)

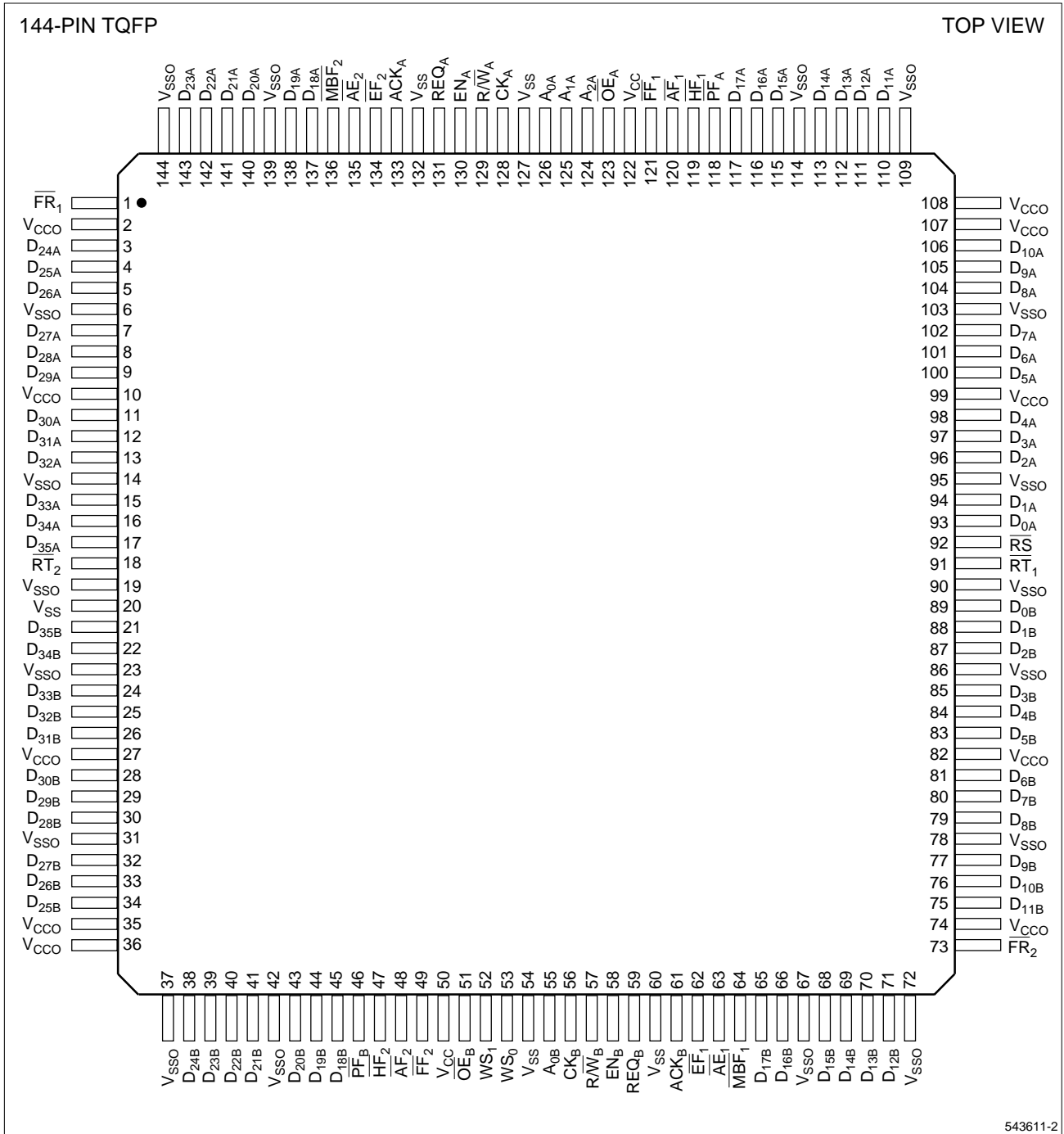

Figure 2. Pin Connections for 144-Pin TQFP Package (Top View)

PIN LIST

SIGNAL NAME	PQFP PIN NO.	TQFP PIN NO.	SIGNAL NAME	PQFP PIN NO.	TQFP PIN NO.	SIGNAL NAME	PQFP PIN122 NO.	TQFP PIN NO.
A _{0A}	1	126	\overline{EF}_1	60	62	D _{20A}	120	140
A _{1A}	2	125	ACK _B	61	61	D _{19A}	122	138
A _{2A}	3	124	REQ _B	63	59	D _{18A}	123	137
\overline{OE}_A	4	123	EN _B	64	58	MBF ₂	124	136
\overline{FF}_1	6	121	R/ \overline{W}_B	65	57	AE ₂	125	135
\overline{AF}_1	7	120	CK _B	66	56	EF ₂	126	134
\overline{HF}_1	8	119	A _{0B}	67	55	ACK _A	127	133
PF _A	9	118	WS ₀	68	53	REQ _A	129	131
D _{17A}	10	117	\overline{WS}_1	69	52	EN _A	130	130
D _{16A}	11	116	\overline{OE}_B	70	51	R/ \overline{W}_A	131	129
D _{15A}	12	115	\overline{FF}_2	72	49	CK _A	132	128
D _{14A}	14	113	\overline{AF}_2	73	48	V _{CC}	5	122
D _{13A}	15	112	\overline{HF}_2	74	47	V _{SSO}	13	114
D _{12A}	16	111	PF _B	75	46	V _{SSO}		109
D _{11A}	17	110	D _{18B}	76	45	V _{CCO}		108
D _{10A}	19	106	D _{19B}	77	44	V _{CCO}	18	107
D _{9A}	20	105	D _{20B}	78	43	V _{SSO}	22	103
D _{8A}	21	104	D _{21B}	80	41	V _{CCO}	26	99
D _{7A}	23	102	D _{22B}	81	40	V _{SSO}	30	95
D _{6A}	24	101	D _{23B}	82	39	V _{SSO}		90
D _{5A}	25	100	D _{24B}	83	38	V _{SSO}	38	86
D _{4A}	27	98	D _{25B}	85	34	V _{CCO}	42	82
D _{3A}	28	97	D _{26B}	86	33	V _{SSO}	46	78
D _{2A}	29	96	D _{27B}	87	32	V _{CCO}	50	74
D _{1A}	31	94	D _{28B}	89	30	V _{CCO}		73
D _{0A}	32	93	D _{29B}	90	29	V _{SSO}		72
\overline{RS}	33	92	D _{30B}	91	28	V _{SSO}	55	67
\overline{RT}_1	34	91	D _{31B}	93	26	V _{SS}	62	60
D _{0B}	35	89	D _{32B}	94	25	V _{SS}		54
D _{1B}	36	88	D _{33B}	95	24	V _{CC}	71	50
D _{2B}	37	87	D _{34B}	97	22	V _{SSO}	79	42
D _{3B}	39	85	D _{35B}	98	21	V _{SSO}		37
D _{4B}	40	84	\overline{RT}_2	100	18	V _{CCO}		36
D _{5B}	41	83	D _{35A}	101	17	V _{CCO}	84	35
D _{6B}	43	81	D _{34A}	102	16	V _{SSO}	88	31
D _{7B}	44	80	D _{33A}	103	15	V _{CCO}	92	27
D _{8B}	45	79	D _{32A}	105	13	V _{SSO}	96	23
D _{9B}	47	77	D _{31A}	106	12	V _{SS}	99	20
D _{10B}	48	76	D _{30A}	107	11	V _{SSO}		19
D _{11B}	49	75	D _{29A}	109	9	V _{SSO}	104	14
D _{12B}	51	71	D _{28A}	110	8	V _{CCO}	108	10
D _{13B}	52	70	D _{27A}	111	7	V _{SSO}	112	6
D _{14B}	53	69	D _{26A}	113	5	V _{CCO}	116	2
D _{15B}	54	68	D _{25A}	114	4	V _{CCO}		1
D _{16B}	56	66	D _{24A}	115	3	V _{SSO}		144
D _{17B}	57	65	D _{23A}	117	143	V _{SSO}	121	139
MBF ₁	58	64	D _{22A}	118	142	V _{SS}	128	132
AE ₁	59	63	D _{21A}	119	141	V _{SS}		127

NOTE:

PINS	COMMENTS	PINS	COMMENTS
V _{CC}	Supply internal logic. Connected to each other.	V _{SS}	Supply internal logic. Connected to each other.
V _{CCO}	Supply output drivers only. Connected to each other.	V _{SSO}	Supply output drivers only. Connected to each other.

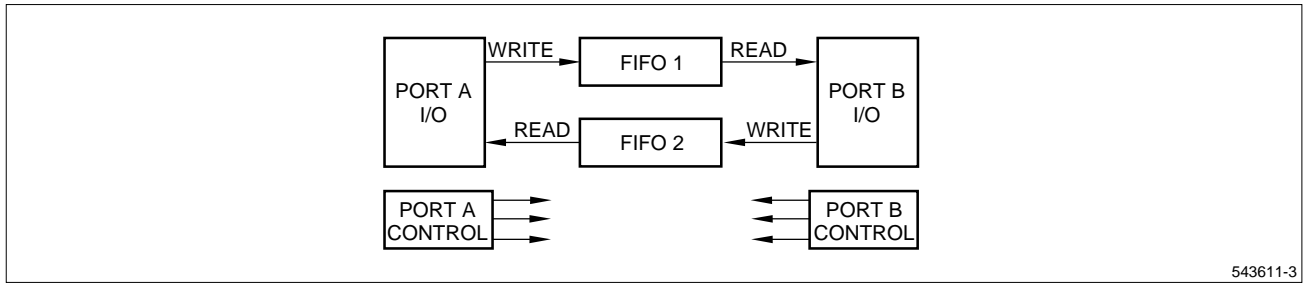

543611-3

Figure 3a. Simplified LH543611/21 Block Diagram

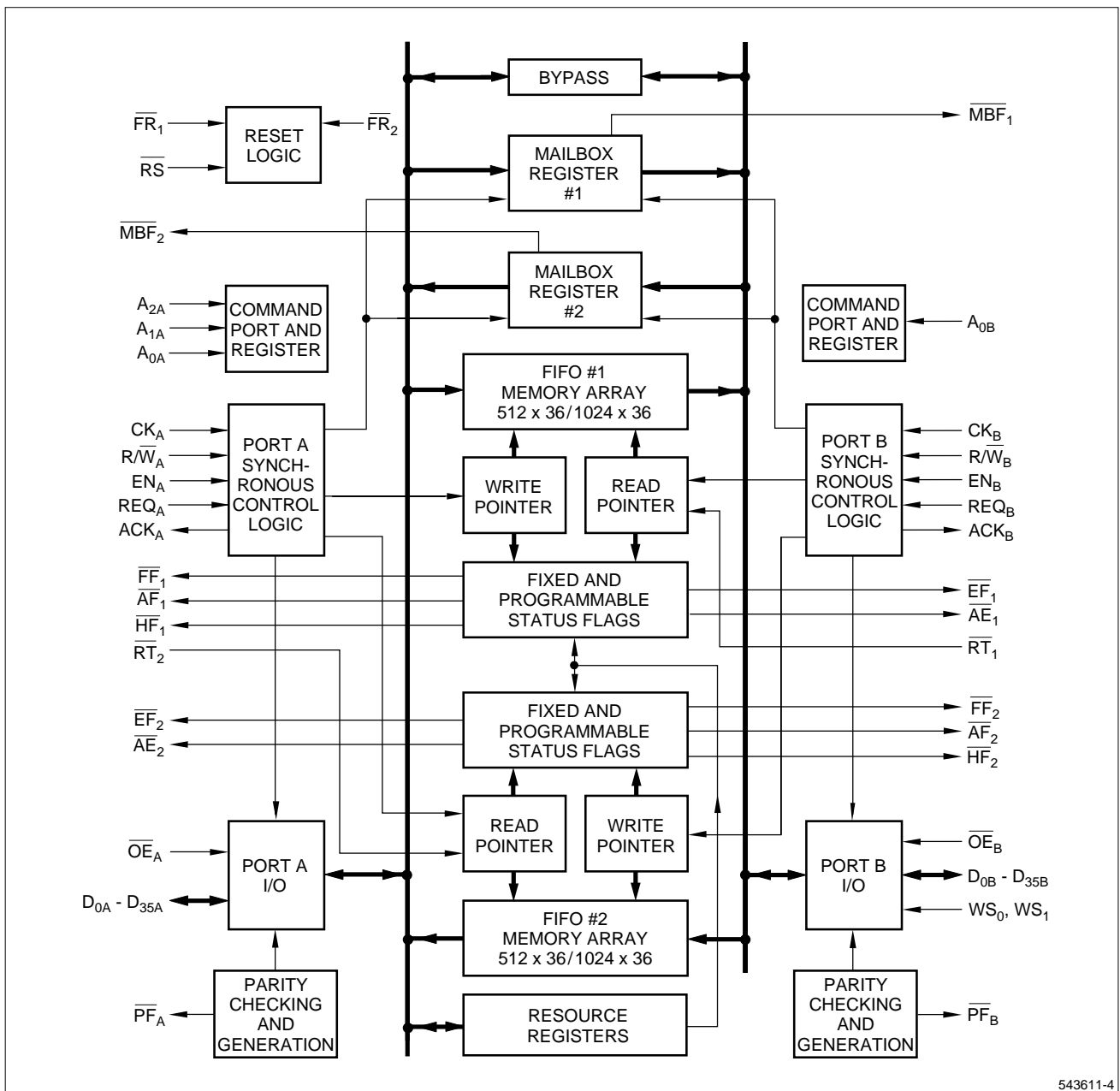

543611-4

Figure 3b. Detailed LH543611/21 Block Diagram

PIN DESCRIPTIONS

PIN	PIN TYPE ¹	DESCRIPTION
GENERAL		
V _{CC} , V _{SS}	V	Power, Ground
$\overline{\text{RS}}$	I	Reset
PORT A		
CK _A	I	Port A Free-Running Clock
$\overline{\text{R}}\overline{\text{W}}_{\text{A}}$	I	Port A Edge-Sampled Read/Write Control
EN _A	I	Port A Edge-Sampled Enable
A _{0A} , A _{1A} , A _{2A}	I	Port A Edge-Sampled Address Pins
$\overline{\text{O}}\overline{\text{E}}_{\text{A}}$	I	Port A Level-Sensitive Output Enable
REQ _A	I	Port A Request/Enable
$\overline{\text{R}}\overline{\text{T}}_2$	I	FIFO #2 Retransmit
D _{0A} – D _{35A}	I/O/Z	Port A Bidirectional Data Bus
$\overline{\text{F}}\overline{\text{F}}_1$	O	FIFO #1 Full Flag (Write Boundary)
$\overline{\text{A}}\overline{\text{F}}_1$	O	FIFO #1 Programmable Almost-Full Flag (Write Boundary)
$\overline{\text{H}}\overline{\text{F}}_1$	O	FIFO #1 Half-Full Flag
$\overline{\text{A}}\overline{\text{E}}_2$	O	FIFO #2 Programmable Almost-Empty Flag (Read Boundary)
$\overline{\text{E}}\overline{\text{F}}_2$	O	FIFO #2 Empty Flag (Read Boundary)
$\overline{\text{M}}\overline{\text{B}}\overline{\text{F}}_2$	O	New-Mail-Alert Flag for Mailbox #2
$\overline{\text{P}}\overline{\text{F}}_{\text{A}}$	O	Port A Parity Flag
ACK _A	O	Port A Acknowledge
PORT B		
CK _B	I	Port B Free-Running Clock
$\overline{\text{R}}\overline{\text{W}}_{\text{B}}$	I	Port B Edge-Sampled Read/Write Control
EN _B	I	Port B Edge-Sampled Enable
A _{0B}	I	Port B Edge-Sampled Address Pin
$\overline{\text{O}}\overline{\text{E}}_{\text{B}}$	I	Port B Level-Sensitive Output Enable
WS ₀ , WS ₁	I	Port B Word-Width Select
REQ _B	I	Port B Request/Enable
$\overline{\text{R}}\overline{\text{T}}_1$	I	FIFO #1 Retransmit
D _{0B} – D _{35B}	I/O/Z	Port B Bidirectional Data Bus
$\overline{\text{F}}\overline{\text{F}}_2$	O	FIFO #2 Full Flag (Write Boundary)
$\overline{\text{A}}\overline{\text{F}}_2$	O	FIFO #2 Programmable Almost-Full Flag (Write Boundary)
$\overline{\text{H}}\overline{\text{F}}_2$	O	FIFO #2 Half-Full Flag
$\overline{\text{A}}\overline{\text{E}}_1$	O	FIFO #1 Programmable Almost-Empty Flag (Read Boundary)
$\overline{\text{E}}\overline{\text{F}}_1$	O	FIFO #1 Empty Flag (Read Boundary)
$\overline{\text{M}}\overline{\text{B}}\overline{\text{F}}_1$	O	New-Mail-Alert Flag for Mailbox #1
$\overline{\text{P}}\overline{\text{F}}_{\text{B}}$	O	Port B Parity Flag
ACK _B	O	Port B Acknowledge

NOTE:

1. I = Input, O = Output, Z = High-Impedance, V = Power Voltage Level

ABSOLUTE MAXIMUM RATINGS¹

PARAMETER	RATING
Supply Voltage to V _{SS} Potential	-0.5 V to 7 V
Signal Pin Voltage to V _{SS} Potential ³	-0.5 V to V _{CC} + 0.5 V
DC Output Current ²	± 40 mA
Storage Temperature Range	-65°C to 150°C
Power Dissipation (Package Limit)	2 Watts (Quad Flat Pack)

NOTES:

- Stresses greater than those listed under 'Absolute Maximum Ratings' may cause permanent damage to the device. This is a stress rating for transient conditions only. Functional operation of the device at these or any other conditions outside those indicated in the 'Operating Range' of this specification is not implied. Exposure to absolute maximum rating conditions for extended periods may affect reliability.
- Outputs should not be shorted for more than 30 seconds. No more than one output should be shorted at any time.
- Negative undershoot of 1.5 V in amplitude is permitted for up to 10 ns, once per cycle.

OPERATING RANGE

SYMBOL	PARAMETER	MIN	MAX	UNIT
T _A	Temperature, Ambient	0	70	°C
V _{CC}	Supply Voltage	4.5	5.5	V
V _{SS}	Supply Voltage	0	0	V
V _{IL}	Logic LOW Input Voltage ¹	-0.5	0.8	V
V _{IH}	Logic HIGH Input Voltage	2.2	V _{CC} + 0.5	V

NOTE:

- Negative undershoot of 1.5 V in amplitude is permitted for up to 10 ns, once per cycle.

DC ELECTRICAL CHARACTERISTICS (OVER OPERATING RANGE)

SYMBOL	PARAMETER	TEST CONDITIONS	MIN	TYP	MAX	UNIT
I _{LI}	Input Leakage Current	V _{CC} = 5.5 V, V _{IN} = 0 V To V _{CC}	-10	-	10	μA
I _{LO}	I/O Leakage Current	$\overline{OE} \geq V_{IH}$, 0 V ≤ V _{OUT} ≤ V _{CC}	-10	-	10	μA
V _{OL}	Logic LOW Output Voltage	I _{OL} = 8.0 mA	-	-	0.4	V
V _{OH}	Logic HIGH Output Voltage	I _{OH} = -8.0 mA	2.4	-	-	V
I _{CC}	Average Supply Current ^{1,2}	Measured at f _{CC} = MAX	-	180	280	mA
I _{CC2}	Average Standby Supply Current ^{1,3}	All Inputs = V _{IHMIN} (Clocks idle)	-	13	25	mA
I _{CC3}	Power-Down Supply Current ¹	All Inputs = V _{CC} - 0.2 V (Clocks idle)	-	0.002	1	mA
I _{CC4}	Power-Down Supply Current ^{1,3}	All Inputs = V _{CC} - 0.2 V (Clocks running at f _{CC} = MAX)	-	10	25	mA

NOTES:

- I_{CC}, I_{CC2}, I_{CC3}, and I_{CC4} are dependent upon actual output loading, and I_{CC}, I_{CC4} are also dependent on cycle rates. Specified values are with outputs open (for I_{CC}: C_L = 0 pF); and, for I_{CC} and I_{CC4}, operating at minimum cycle times.
- I_{CC} (MAX.) using V_{CC} = MAX = 5.5 V and 'worst case' data pattern. I_{CC} (TYP.) using V_{CC} = 5 V and 'average' data pattern.
- I_{CC2} (TYP.) and I_{CC4} (TYP.) using V_{CC} = 5 V and T_A = 25°C.

AC TEST CONDITIONS

PARAMETER	RATING
Input Pulse Levels	V _{SS} to 3 V
Input Rise and Fall Times (10% to 90%)	5 ns
Output Reference Levels	1.5 V
Input Timing Reference Levels	1.5 V
Output Load, Timing Tests	Figure 5

CAPACITANCE ^{1,2}

PARAMETER	RATING
C _{IN} (Input Capacitance)	8 pF
C _{OUT} (Output Capacitance)	8 pF

NOTES:

1. Sample tested only.
2. Capacitances are maximum values at 25°C, measured at 1.0 MHz, with V_{IN} = 0 V.

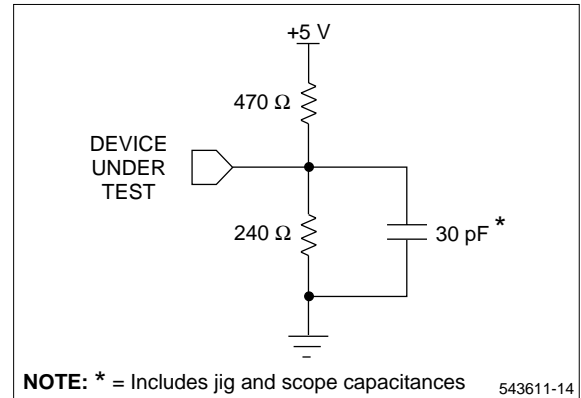

Figure 4. Output Load Circuit

AC ELECTRICAL CHARACTERISTICS ¹ (V_{CC} = 5 V ± +10%, T_A = 0°C to 70°C)

SYMBOL	DESCRIPTION	-18		-20		-25		-30		-35		UNITS
		MIN	MAX	MIN	MAX	MIN	MAX	MIN	MAX	MIN	MAX	
f _{CC}	Clock Cycle Frequency	—	55	—	50	—	40	—	33	—	28.5	MHz
t _{CC}	Clock Cycle Time	18	—	20	—	25	—	30	—	35	—	ns
t _{CH}	Clock HIGH Time	7	—	8	—	10	—	12	—	15	—	ns
t _{CL}	Clock LOW Time	7	—	8	—	10	—	12	—	15	—	ns
t _{DS}	Data Setup Time	7.5	—	7.5	—	9	—	10	—	12	—	ns
t _{DH}	Data Hold Time	0.5	—	0.5	—	0.5	—	0.5	—	0.5	—	ns
t _{ES}	Enable Setup Time	5.5	—	5.5	—	7.5	—	8.5	—	10.5	—	ns
t _{EH}	Enable Hold Time	0.5	—	0.5	—	0.5	—	0.5	—	0.5	—	ns
t _{RWS}	Read/Write Setup Time	5.5	—	5.5	—	7.5	—	8.5	—	10.5	—	ns
t _{RWH}	Read/Write Hold Time	0.5	—	0.5	—	0.5	—	0.5	—	0.5	—	ns
t _{RQS}	Request Setup Time	5.5	—	5.5	—	7.5	—	8.5	—	10.5	—	ns
t _{RQH}	Request Hold Time	0.5	—	0.5	—	0.5	—	0.5	—	0.5	—	ns
t _{AS}	Address Setup Time ²	7.5	—	7.5	—	9	—	10	—	12	—	ns
t _{AH}	Address Hold Time ²	0.5	—	0.5	—	0.5	—	0.5	—	0.5	—	ns
t _{WSS}	Width Select Setup Time	5.5	—	5.5	—	7.5	—	8.5	—	10.5	—	ns
t _{WSH}	Width Select Hold Time ³	0.5	—	0.5	—	0.5	—	0.5	—	0.5	—	ns
t _A	Data Output Access Time	—	13	—	13.8	—	16	—	20	—	25	ns
t _{ACK}	Acknowledge Access Time	—	9.5	—	9.5	—	13	—	16	—	18	ns
t _{OH}	Output Hold Time	4	—	4	—	4	—	4	—	4	—	ns
t _{ZX}	Output Enable Time, \overline{OE} LOW to D ₀ – D ₃₅ Low-Z ³	1.5	—	1.5	—	2	—	3	—	3	—	ns
t _{XZ}	Output Disable Time, \overline{OE} HIGH to D ₀ – D ₃₅ High-Z ³	—	9	—	9	—	12	—	15	—	20	ns
t _{EF}	Clock to \overline{EF} Flag Valid	—	14	—	14.5	—	19	—	22	—	27	ns
t _{FF}	Clock to \overline{FF} Flag Valid	—	14	—	14.5	—	19	—	22	—	27	ns
t _{HF}	Clock to \overline{HF} Flag Valid	—	14	—	14.5	—	19	—	22	—	27	ns
t _{AE}	Clock to \overline{AE} Flag Valid	—	14.5	—	15	—	19	—	22	—	27	ns
t _{AF}	Clock to \overline{AF} Flag Valid	—	14.5	—	15	—	19	—	22	—	27	ns
t _{MBF}	Clock to \overline{MBF} Flag Valid	—	10	—	10	—	13	—	18	—	23	ns
t _{PF}	Data to Parity Flag Valid ⁴	—	14	—	14	—	17	—	20	—	25	ns
t _{RS}	Reset/Retransmit Pulse Width ⁵	18	—	20	—	25	—	30	—	35	—	ns
t _{RSS}	Reset/Retransmit Setup Time ⁶	15	—	16	—	20	—	25	—	30	—	ns
t _{RSH}	Reset/Retransmit Hold Time ⁶	7.2	—	8	—	10	—	15	—	20	—	ns
t _{RF}	Reset LOW to Flag Valid	—	21	—	21	—	25	—	30	—	35	ns
t _{FRL}	First Read Latency ⁷	18	—	20	—	25	—	30	—	35	—	ns
t _{FWL}	First Write Latency ⁸	18	—	20	—	25	—	30	—	35	—	ns
t _{BS}	Bypass Data Setup	8.5	—	8.5	—	10	—	13	—	15	—	ns
t _{BH}	Bypass Data Hold	2	—	2	—	3	—	4	—	5	—	ns
t _{BA}	Bypass Data Access	—	15.5	—	16	—	18	—	23	—	28	ns
t _{SKEW1}	Skew Time Read-to-Write Clock	14	—	14.5	—	19	—	22	—	27	—	ns
t _{SKEW2}	Skew Time Write-to-Read Clock	14	—	14.5	—	19	—	22	—	27	—	ns

NOTES:

- Timing measurements performed at 'AC Test Condition' levels.
- t_{AS}, t_{AH} address setup times and hold times need only be satisfied at clock edges which occur while the corresponding enables are being asserted.
- Values are guaranteed by design; not currently production tested.
- Measured with Parity Flag operating in flowthrough mode.
- When CK_A or CK_B is enabled; t_{RS} = t_{RSS} + t_{CH} + t_{RSH}.
- t_{RSS} and/or t_{RSH} need not be met unless a rising edge of CK_A occurs while EN_A is being asserted, or else a rising edge of CK_B occurs while EN_B is being asserted.
- t_{FRL} is the minimum first-write-to-first-read delay, following an empty condition, which is required to assure valid read data.
- t_{FWL} is the minimum first-read-to-first-write delay, following a full condition, which is required to assure successful writing of data.

OPERATIONAL DESCRIPTION

Reset

The device is reset whenever the asynchronous Reset (\overline{RS}) input is taken LOW, and at least one rising edge and one falling edge of both CK_A and CK_B occur while \overline{RS} is LOW. A reset operation is required after power-up, before the first write operation may occur. The LH543611/21 is fully ready for operation after being reset. No device programming is required if the default states described below are acceptable.

A reset operation initializes the read-address and write-address pointers for FIFO #1 and FIFO #2 to those FIFO's first physical memory locations. If the respective outputs are enabled, the initial contents of these first locations appear at the outputs. FIFO and mailbox status flags are updated to indicate an empty condition. In addition, the programmable-status-flag offset values are initialized to eight. Thus, the $\overline{AE}_1/\overline{AE}_2$ flags get asserted within eight locations of an empty condition, and the $\overline{AF}_1/\overline{AF}_2$ flags likewise get asserted within eight locations of a full condition, for FIFO #1/FIFO #2 respectively.

Bypass Operation

During reset (whenever \overline{RS} is LOW) the device acts as a registered transceiver, bypassing the internal FIFO memories. Port A acts as the master port. A write or read operation on Port A during reset transfers data directly to or from Port B. Port B is considered to be the slave, and cannot perform write or read operations independently on its own during reset.

The direction of the bypass data transmission is determined by the R/\overline{W}_A control input, which does not get overridden by the \overline{RS} input. Here, a 'write' operation means passing data from Port A to Port B, and a 'read' operation means passing data from Port B to Port A.

The bypass capability may be used to pass initialization or configuration data directly between a master processor and a peripheral device during reset.

Address Modes

Address pins select the device resource to be accessed by each port. Port A has three resource-register-select inputs, A_{0A} , A_{1A} , and A_{2A} , which select between FIFO access, mailbox-register access, control-register access, and programmable flag-offset-value-register access. Port B has a single address input, A_{0B} , to select between FIFO access or mailbox-register access.

The status of the resource-register-select inputs is sampled at the rising edge of an enabled clock (CK_A or CK_B). Resource-register select-input address definitions are summarized in Table 1.

Table 1. Resource-Register Addresses

A_{2A}	A_{1A}	A_{0A}	RESOURCE
PORT A			
H	H	H	FIFO
H	H	L	Mailbox
H	L	H	$\overline{AF}_2, \overline{AE}_2, \overline{AF}_1, \overline{AE}_1$ Flag Offsets Register (36-Bit Mode)
H	L	L	Control Register Flag-Synchronization and Parity Operating Mode
L	H	H	\overline{AE}_1 Flag Offset Register
L	H	L	\overline{AF}_1 Flag Offset Register
L	L	H	\overline{AE}_2 Flag Offset Register
L	L	L	\overline{AF}_2 Flag Offset Register
A_{0B}			RESOURCE
PORT B			
H			FIFO
L			Mailbox

Control Register

The eighteen Control-Register bits govern the synchronization mode of the fullness-status flags at each port, the choice of odd or even parity at both ports, the enabling of parity generation for data flow at each port, the optional latching behavior of the parity-error flags at each port, and the selection of a full-word or half-word or single-byte field for parity checking. A reset operation initializes the LH543611/21 Control Register for LH5420/LH543601-compatible operation, but it may be reprogrammed at will at any time during LH543611/21 operation.

FIFO Write

Port A writes to FIFO #1, and Port B writes to FIFO #2. A write operation is initiated on the rising edge of a clock (CK_A or CK_B) whenever: the appropriate enable (EN_A or EN_B) is held HIGH; the appropriate request (REQ_A or REQ_B) is held HIGH; the appropriate Read/Write control (R/\overline{W}_A or R/\overline{W}_B) is held LOW; the FIFO address is selected for the address inputs ($A_{2A} - A_{0A}$ or A_{0B}); and the prescribed setup times and hold times are observed for all of these signals. Setup times and hold times must also be observed on the data-bus pins ($D_{0A} - D_{35A}$ or $D_{0B} - D_{35B}$).

Normally, the appropriate Output Enable signal (\overline{OE}_A or \overline{OE}_B) is HIGH, to disable the outputs at that port, so that the data word present on the bus from external sources gets stored. However, a 'loopback' mode of operation also is possible, in which the data word supplied by the outputs of one internal FIFO is 'turned around' at the port and read back into the other FIFO. In this mode, the outputs at the port are not disabled. To remain within specification for all timing parameters, the Clock Cycle Frequency must be reduced slightly below the value

OPERATIONAL DESCRIPTION (cont'd)

which otherwise would be permissible for that speed grade of LH543611/21.

When a FIFO full condition is reached, write operations are locked out. Following the first read operation from a full FIFO, another memory location is freed up, and the corresponding Full Flag is deasserted ($\overline{FF} = \text{HIGH}$). The first write operation should begin no earlier than a First Write Latency (t_{FWL}) after the first read operation from a full FIFO, to ensure that correct read data are retrieved. (See Figures 33 and 34.)

FIFO Read

Port A reads from FIFO #2, and Port B reads from FIFO #1. A read operation is initiated on the rising edge of a clock (CK_A or CK_B) whenever: the appropriate enable (EN_A or EN_B) is held HIGH; the appropriate request (REQ_A or REQ_B) is held HIGH; the appropriate Read/Write control (R/\overline{W}_A or R/\overline{W}_B) is held HIGH; the FIFO address is selected for the address inputs ($A_{2A} - A_{0A}$ or A_{0B}); and the prescribed setup times and hold times are observed for all of these signals. Read data becomes valid on the data-bus pins ($D_{0A} - D_{35A}$ or $D_{0B} - D_{35B}$) by a time t_A after the rising clock (CK_A or CK_B) edge, provided that the data outputs are enabled.

\overline{OE}_A and \overline{OE}_B are assertive-LOW, asynchronous, Output Enable control input signals. Their effect is only to enable or disable the output drivers of the respective port. Disabling the outputs does *not* disable a read operation; data transmitted to the corresponding output register will remain available later, when the outputs again are enabled, unless it subsequently is overwritten.

When an empty condition is reached, read operations are locked out until a valid write operation(s) has loaded additional data into the FIFO. Following the first write to an empty FIFO, the corresponding empty flag (\overline{EF}) will be deasserted (HIGH). The first read operation should begin no earlier than a First Read Latency (t_{FRL}) after the first write to an empty FIFO, to ensure that correct read data words are retrieved. (See Figures 31 and 32.)

Dedicated FIFO Status Flags

Six dedicated FIFO status flags are included for Full (\overline{FF}_1 and \overline{FF}_2), Half-Full (\overline{HF}_1 and \overline{HF}_2), and Empty (\overline{EF}_1 and \overline{EF}_2). \overline{FF}_1 , \overline{HF}_1 , and \overline{EF}_1 indicate the status of FIFO #1; and \overline{FF}_2 , \overline{HF}_2 , and \overline{EF}_2 indicate the status of FIFO #2.

A Full Flag is asserted following the first subsequent rising clock edge for a write operation which fills the FIFO. A Full Flag is deasserted following the first subsequent falling clock edge for a read operation to a full FIFO. A Half-Full Flag is updated following the first subsequent rising clock edge of a read or write operation to a FIFO which changes its 'half-full' status. An Empty Flag is asserted following the first subsequent rising clock edge for a read operation which empties the FIFO. An Empty Flag is deasserted following the falling clock edge for a write operation to an empty FIFO.

Programmable Status Flags

Four programmable FIFO status flags are provided, two for Almost-Full (\overline{AF}_1 and \overline{AF}_2), and two for Almost-Empty (\overline{AE}_1 and \overline{AE}_2). Thus, each port has two programmable flags to monitor the status of the two internal FIFO buffer memories. The offset values for these flags are initialized to eight locations from the respective FIFO boundaries during reset, but can be reprogrammed over the entire FIFO depth.

An Almost-Full Flag is asserted following the first subsequent rising clock edge after a write operation which has partially filled the FIFO up to the 'almost-full' offset point. An Almost-Full Flag is deasserted following the first subsequent falling clock edge after a read operation which has partially emptied the FIFO down past the 'almost-full' offset point. An Almost-Empty Flag is asserted following the first subsequent rising clock edge after a read operation which has partially emptied the FIFO down to the 'almost-empty' offset point. An Almost-Empty Flag is deasserted following the first subsequent falling clock edge after a write operation which has partially filled the FIFO up past the 'almost-empty' offset point.

Flag offsets may be written or read through the Port A data bus. All four programmable FIFO status flag offsets can be set simultaneously through a single 36-bit status word; or, each programmable flag offset can be set individually, through one of four nine-bit (LH543611) or ten-bit (LH543621) status words. Tables 3a and 3b illustrate the data format for flag-programming words. Note that when all four offsets are set simultaneously in an LH543621, the settings are limited to magnitudes expressible in nine bits; for larger offset values, the individual setting option must be used. (See Figure 3b.)

Also, Tables 4a and 4b define the meaning of each of the five flags, both the dedicated flags and the programmable flags, for the LH543611 and LH543621 respectively.

NOTE: Control inputs which may affect the computation of flag values at a port generally should not change while the clock for that port is HIGH, since some updating of flag values takes place on the *falling* edge of the clock.

Mailbox Operation

Two mailbox registers are provided for passing system hardware or software control/status words between ports. Each port can read its own mailbox and write to the other port's mailbox. Mailbox access is performed on the rising edge of the controlling FIFO's clock, with the mailbox address selected and the enable (EN_A or EN_B) HIGH. That is, writing to Mailbox Register #1, or reading from Mailbox Register #2, is synchronized to CK_A ; and writing to Mailbox Register #2, or reading from Mailbox Register #1, is synchronized to CK_B .

The $R/\overline{W}_{A/B}$ and $\overline{OE}_{A/B}$ pins control the direction and availability of mailbox-register accesses. Each mailbox register has its own New-Mail-Alert Flag (\overline{MBF}_1 and

OPERATIONAL DESCRIPTION (cont'd)

$\overline{\text{MBF}}_2$), which is synchronized to the reading port's clock. These New-Mail-Alert Flags are status indicators only, and cannot inhibit mailbox-register read or write operations.

Request Acknowledge Handshake

A synchronous request-acknowledge handshake feature is provided for each port, to perform boundary synchronization between asynchronously-operated ports. The use of this feature is optional. When it is used, the Request input ($\text{REQ}_{A/B}$) is sampled at a rising clock edge. With $\text{REQ}_{A/B}$ HIGH, $\text{R}/\overline{\text{W}}_{A/B}$ determines whether a FIFO read operation or a FIFO write operation is being requested. The Acknowledge output ($\text{ACK}_{A/B}$) is updated during the following clock cycle(s). $\text{ACK}_{A/B}$ meets the setup and hold time requirements of the Enable input (EN_A or EN_B). Therefore, $\text{ACK}_{A/B}$ may be tied back to the enable input to directly gate FIFO accesses, at a slight decrease in maximum operating frequency.

The assertion of $\text{ACK}_{A/B}$ signifies that $\text{REQ}_{A/B}$ was asserted. However, $\text{ACK}_{A/B}$ does not depend logically on $\text{EN}_{A/B}$; and thus the assertion of $\text{ACK}_{A/B}$ does *not* prove that a FIFO write access or a FIFO read access actually took place. While $\text{REQ}_{A/B}$ and $\text{EN}_{A/B}$ are being held HIGH, $\text{ACK}_{A/B}$ may be considered as a synchronous, predictive boundary flag. That is, $\text{ACK}_{A/B}$ acts as a synchronized predictor of the Almost-Full Flag $\overline{\text{AF}}$ for write operations, or as a synchronized predictor of the Almost-Empty Flag $\overline{\text{AE}}$ for read operations.

Outside the 'almost-full' region and the 'almost-empty' region, $\text{ACK}_{A/B}$ remains continuously HIGH whenever $\text{REQ}_{A/B}$ is held continuously HIGH. Within the 'almost-full' region or the 'almost-empty' region, $\text{ACK}_{A/B}$ occurs only on every *third* cycle, to prevent an overrun of the FIFO's actual full or empty boundaries and to ensure that the t_{FWL} (first write latency) and t_{FRL} (first read latency) specifications are satisfied before $\text{ACK}_{A/B}$ is received.

The 'almost-full region' is defined as 'that region, where the Almost-Full Flag is being asserted'; and the 'almost-empty region' as 'that region, where the Almost-Empty Flag is being asserted.' Thus, the extent of these 'almost' regions depends on how the system has programmed the offset values for the Almost-Full Flags and the Almost-Empty Flags. If the system has *not* programmed them, then these offset values remain at their default values, eight in each case.

If a write attempt is unsuccessful because the corresponding FIFO is full, or if a read attempt is unsuccessful because the corresponding FIFO is empty, $\text{ACK}_{A/B}$ is *not* asserted in response to $\text{REQ}_{A/B}$.

If the REQ/ACK handshake is not used, then the $\text{REQ}_{A/B}$ input may be used as a second enable input, at a possible minor loss in maximum operating speed. In this case, the $\text{ACK}_{A/B}$ output may be ignored.

WARNING: Whether or not the REQ/ACK handshake is being used, the $\text{REQ}_{A/B}$ input for a port *must* be asserted for that port to function at all – for FIFO, mailbox, or data-bypass operation.

Data Retransmit

A retransmit operation resets the read-address pointer of the corresponding FIFO (#1 or #2) back to the first FIFO physical memory location, so that data may be reread. The write pointer is not affected. The status flags are updated; and a block of up to 512 or 1024 data words, which previously had been written into and read from a FIFO, can be retrieved. The block to be retransmitted is bounded by the first FIFO memory location, and the FIFO memory location addressed by the write pointer. FIFO #1 retransmit is initiated by strobing the $\overline{\text{RT}}_1$ pin LOW. FIFO #2 retransmit is initiated by strobing the $\overline{\text{RT}}_2$ pin LOW. Read and write operations to a FIFO should be stopped while the corresponding Retransmit signal is being asserted.

Parity Checking

The Parity Check Flags, $\overline{\text{PF}}_A$ and $\overline{\text{PF}}_B$, are asserted (LOW) whenever there is a parity error in the data word present on the Port A data bus or the Port B data bus respectively. The inputs to the parity-evaluation logic come directly (via isolation transistors) from the data-bus bonding *pads*, in each case. Thus, $\overline{\text{PF}}_A$ and $\overline{\text{PF}}_B$ provide parity-error indications for whatever 36-bit words are present at Port A and Port B respectively, regardless of whether those words originated within the LH543611/21 or in the external system.

The four bytes of a 36-bit data word are grouped as $D_0 - D_8$, $D_9 - D_{17}$, $D_{18} - D_{26}$, and $D_{27} - D_{35}$. The parity of each nine-bit byte is individually checked, and the four single-bit parity indications are logically ORed and inverted to produce the Parity-Flag output.

If the Parity Policy bit (Control-Register bit 09) is HIGH, then parity at Port B will be computed over the field defined by the Word-Width Selection control inputs WS_0 and WS_1 , and then may be for full-words, for half-words, or for single bytes. Otherwise, parity will be computed over full-words regardless of the setting of WS_0 and WS_1 .

Parity checking is initialized for odd parity at reset, but can be reprogrammed for even parity or for odd parity during operation. Control-Register bit 00 (zero) selects the parity mode, odd or even. (See Tables 3, 5, and 6, and Figure 10.)

All nine bits of each byte are treated alike by the parity logic. The byte parity over the nine bits is compared with the Parity Mode bit in the Control Register, to generate a byte-parity-error indication. Then, the four byte-parity-error signals are NORed together, to compute the assertive-LOW parity-flag value. This value may pass through to the output pin on a flowthrough basis, or it may be latched, according to the setting of the Control-Register latching bit for that port (bit 02 or bit 11). (See Figure 6 for an example of parity checking.)

Parity Generation

Unlike parity checking, parity generation at a port operates only when it is explicitly invoked by setting the corresponding Control-Register bit for that port (bit 01 or bit 10) HIGH. The presumed division of words into bytes still remains the same as for parity checking. However, it is no longer true that all nine bits of each byte are treated alike; now, the most-significant bit of each byte is explicitly designated as the parity bit for that byte. The parity-generation process records a new value into that bit position for each byte passing through the port. (See Figure 6 for an example of parity generation.)

If the Parity Policy bit (Control Register bit 09), is HIGH, parity at Port B will be generated for full-words, for half-words, or for single bytes according to the setting of the Word-Width Selection control inputs WS_0 and WS_1 . Otherwise, parity will be generated for full-words regardless of the setting of WS_0 and WS_1 .

The parity bits generated may be even or odd, according to the setting of Control-Register bit 00, which is the same bit that governs their interpretation during parity checking.

Word-Width Selection and Byte-Order Reversal on Port B

The word width of data access on Port B is selected by the WS_0 and WS_1 control inputs. WS_0 and WS_1 both are tied HIGH for 36-bit access; they both are tied LOW for single-byte access. For double-byte access, WS_1 is tied LOW; WS_0 is tied HIGH for straight-through transmission of 36-bit words, or tied LOW for on-the-fly byte-order reversal of the four bytes in the word ('big-endian ↔ little-endian conversion'). (See Table 2a and 2b.)

In the single-byte-access or double-byte-access modes, FIFO write operations on Port B essentially pack the data to form 36-bit words, as viewed from Port A. Similarly, single-byte or double-byte FIFO read operations on Port B essentially unpack 36-bit words through a series of shift operations. FIFO status flags are updated following the last access which forms a complete 36-bit transfer.

Since the values for each status flag are computed by logic directly associated with one of the two FIFO-memory arrays, and not by logic associated with Port B, *the flag values reflect the array fullness situation in terms of complete 36-bit words*, and not in terms of bytes or double bytes.

However, there is no such restriction for switching from writing to reading, or from reading to writing, at Port B. As long as t_{RWS} , t_{DS} , and t_A are satisfied, R/\overline{W}_B may change state after *any* single-byte or double-byte access, and not only after a full 36-bit-word access.

Also, WS_0 and WS_1 may be changed between full-words during FIFO operation, without the need for any reset operation, or for passing any dummy words on through in advance of real data. If such a change is made other than at a full-word boundary, however, at least one dummy word should be used.

Also, the word-width-matching feature continues to operate properly in 'loopback' mode.

Note that the programmable word-width-matching feature is *only* supported for FIFO accesses. Mailbox and Data Bypass operations do *not* support word-width matching between Port A and Port B. Tables 2a and 2b and Figures 7, 8, and 9, summarize word-width selection for Port B.

Table 2a. Port B Word-Width Selection

WS_1	WS_0	PORT B DATA WIDTH
H	H	36-Bit
H	L	36-Bit with Byte-Order Reversal
L	H	18-Bit
L	L	9-Bit

PARITY CHECKING				
			D _{A/B} 35	D _{A/B} 0
Output word:	100111100	000111100	100111000	000111000
Odd parity:	Parity of Bytes = 0110; (1 = Byte Parity Error) \overline{PF} = L			
Even parity:	Parity of Bytes = 1001; (1 = Byte Parity Error) \overline{PF} = L			
PARITY GENERATION				
			D _{A/B} 35	D _{A/B} 0
Input word:	100111100	000111100	100111000	000111000
Output, odd parity:	100111100	100111100	000111000	000111000
Output, even parity:	000111100	000111100	100111000	100111000

Figure 6. Example of Parity Checking and Generation

Table 2b. Bus Funneling/Defunneling *

DA[35:0]						WS = 3 (HH)				WS = 2 (HL)				WS = 1 (LH)				WS = 0 (LL)			
						DB[35:0]				DB[35:0]				DB[35:18]		DB[17:0]		DB[35:9]			DB[8:0]
0	B3	B2	B1	B0	0	B3	B2	B1	B0	B0	B1	B2	B3	B3	B2	B1	B0	B3	B2	B1	B0
1	B7	B6	B5	B4	1	B7	B6	B5	B4	B4	B5	B6	B7	B1	B0	B3	B2	B0	B3	B2	B1
					2									B7	B6	B5	B4	B1	B0	B3	B2
					3									B5	B4	B7	B6	B2	B1	B0	B3
					4													B7	B6	B5	B4

* NOTE: B0, B1, . . . , represent data bytes.

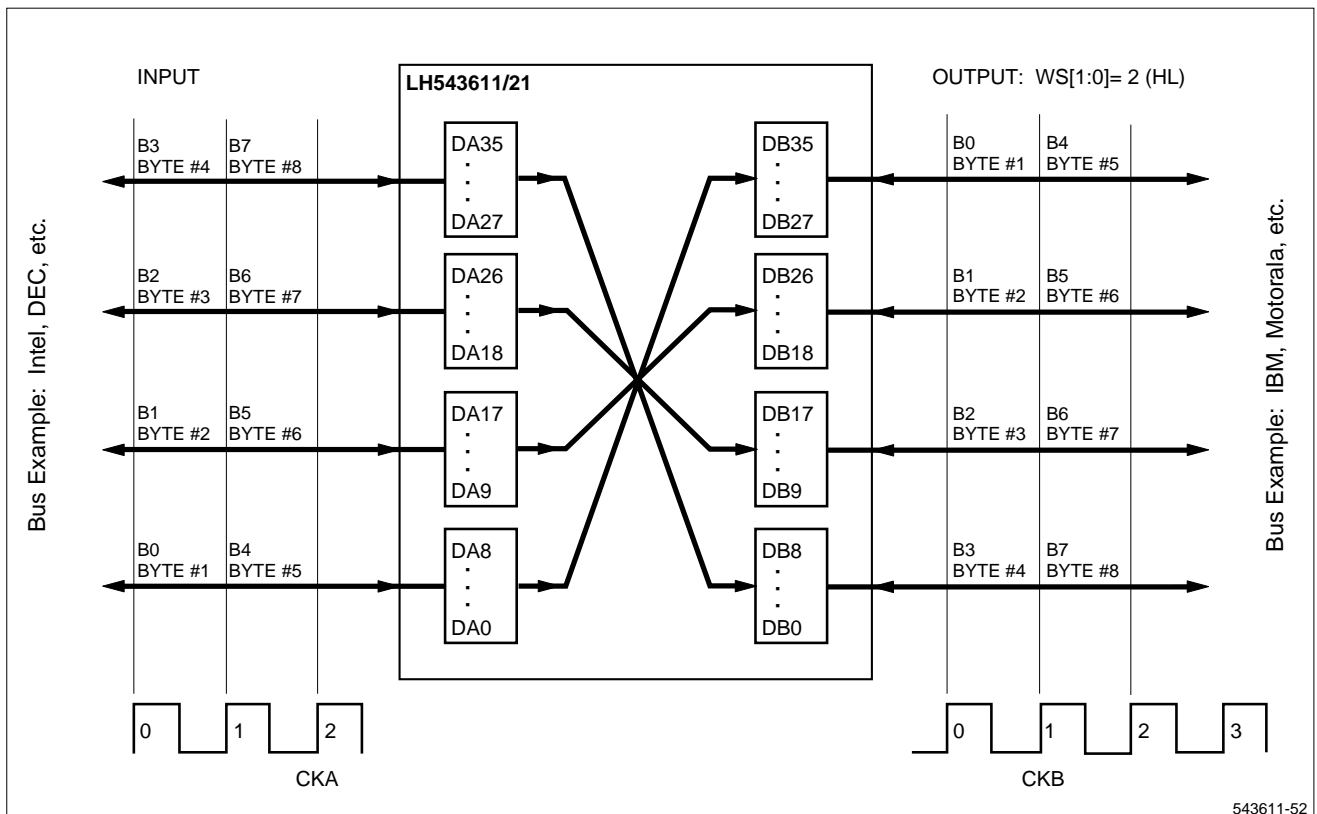

Figure 7. Example of 36-to-36 Byte Order Reversal

PORT B WORD-WIDTH SELECTION

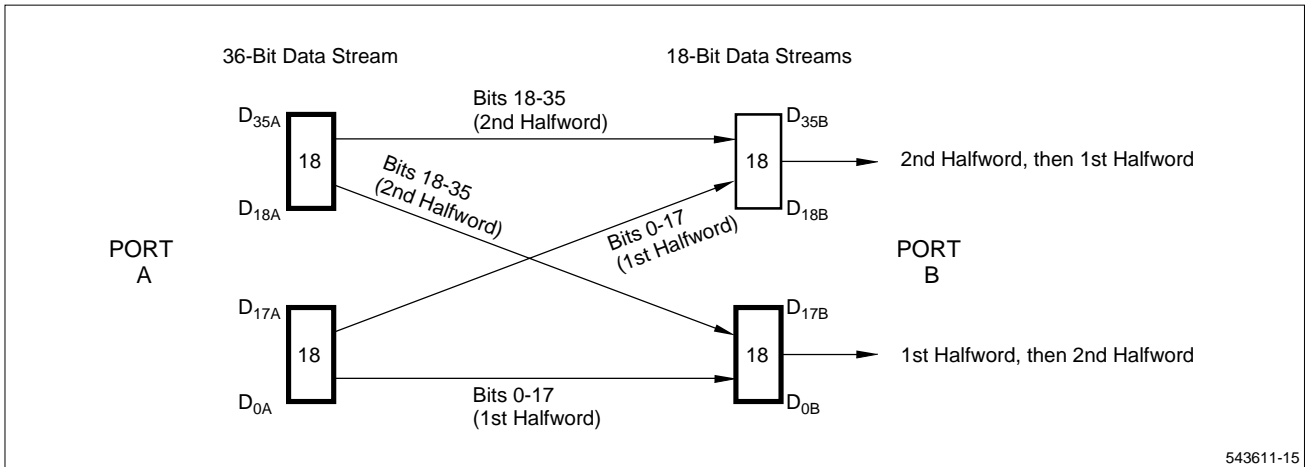

Figure 8a. 36-to-18 Funnelling Through FIFO #1

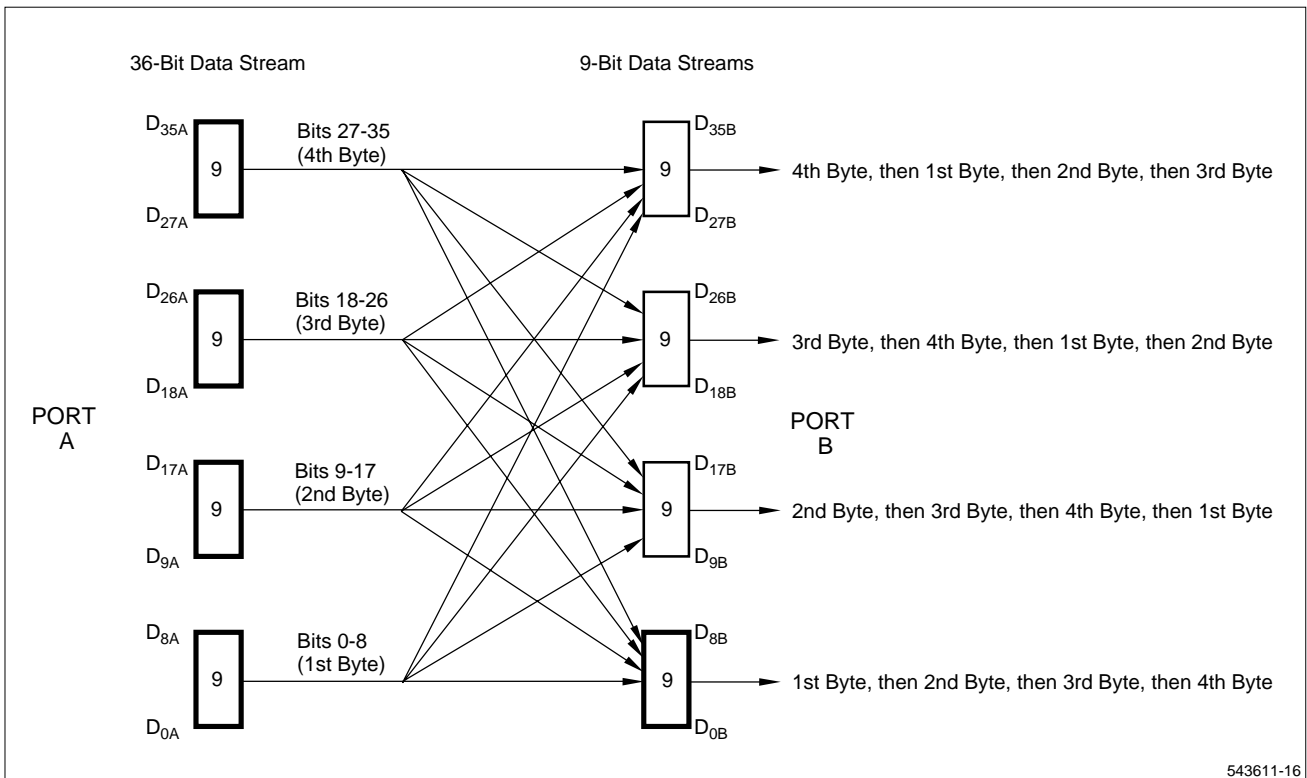

Figure 8b. 36-to-9 Funnelling Through FIFO #1

NOTES:

1. The heavy black borders on register segments indicate the main data path, suitable for most applications. Alternate paths feature a different ordering of bytes within a word, at Port B.
2. The funnelling process does not change the ordering of bits within a byte. Halfwords (Figure 8a) or bytes (Figure 8b) are transferred in parallel form from Port A to Port B.
3. The word-width setting may be changed during system operation; however, two clock intervals should be allowed for these signals to settle, before again attempting to read D_{0B} – D_{35B}. Also, incomplete data words may occur, when the word width is changed from shorter to longer at an inappropriate point in the data block passing through the FIFO.

PORT B WORD-WIDTH SELECTION

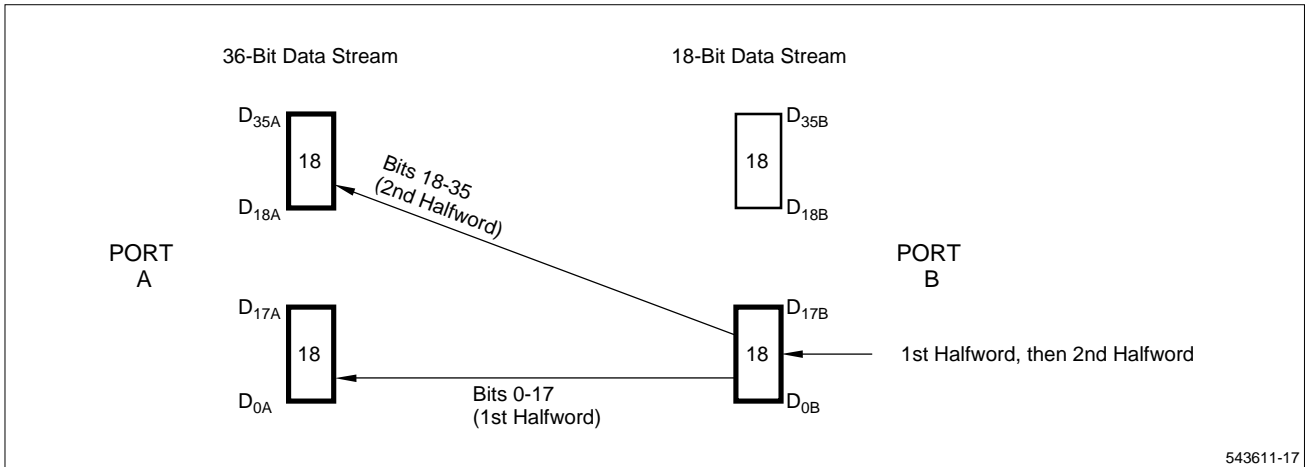

Figure 9a. 18-to-36 Defunneling Through FIFO #2

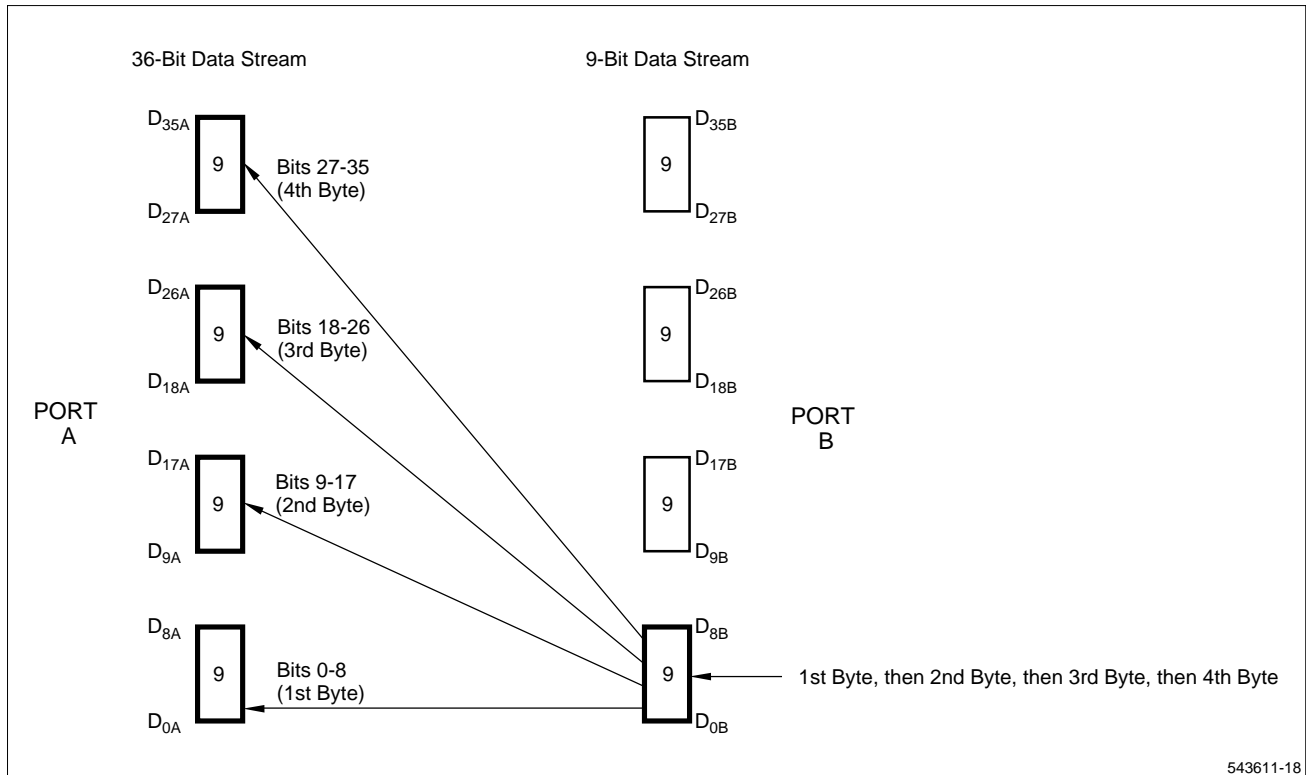

Figure 9b. 9-to-36 Defunneling Through FIFO #2

NOTES:

1. The heavy black borders on register segments indicate the only data paths used. The other byte segments of Port B do not participate in the data path during defunneling.
2. The defunneling process does not change the ordering of bits within a byte. Halfwords (Figure 9a) or bytes (Figure 9b) are transferred in parallel form from Port B to Port A.
3. The word-width setting may be changed during system operation; however, two dock intervals should be allowed for these signals to settle, before again attempting to send data. Also, incomplete data words may occur, when the word width is changed from shorter to longer at an inappropriate point in the data block passing through the FIFO.

Table 3a. LH543611 Resource-Register Programming

RESOURCE-REGISTER ADDRESS			RESOURCE-REGISTER CONTENTS						
A2A	A1A	A0A							
			NORMAL FIFO OPERATION						
H	H	H	D _{35A}				D _{0A}		
			X...				...X		
			MAILBOX						
H	H	L	D _{35A}				D _{0A}		
			X...				...X		
			$\overline{AF}_2, \overline{AE}_2, \overline{AF}_1, \overline{AE}_1$ FLAG REGISTER (36-BIT MODE)						
H	L	H	D _{35A} . . . D _{27A}	D _{26A} . . . D _{18A}	D _{17A} . . . D _{9A}	D _{8A} . . . D _{0A}			
			\overline{AF}_2 Offset ¹	\overline{AE}_2 Offset ¹	\overline{AF}_1 Offset ¹	\overline{AE}_1 Offset ¹			
			CONTROL REGISTER: FLAG SYNCHRONIZATION, PARITY CONFIGURATION						
H	L	L	D _{35A}	D _{18A}	D _{17A}	D _{9A}	D _{8A}	D _{1A}	D _{0A}
			X...	...X	Port B Control ³	Port A Control ³	PM ²		
			9-BIT \overline{AE}_1 FLAG OFFSET REGISTER						
L	H	H	D _{35A}				D _{9A}	D _{8A} . . . D _{0A}	
			X...				...X	\overline{AE}_1 Offset ¹	
			9-BIT \overline{AF}_1 FLAG OFFSET REGISTER						
L	H	L	D _{35A}				D _{9A}	D _{8A} . . . D _{0A}	
			X...				..X	\overline{AF}_1 Offset ¹	
			9-BIT \overline{AE}_2 FLAG OFFSET REGISTER						
L	L	H	D _{35A}				D _{9A}	D _{8A} . . . D _{0A}	
			X...				...X	\overline{AE}_2 Offset ¹	
			9-BIT \overline{AF}_2 FLAG OFFSET REGISTER						
L	L	L	D _{35A}				D _{9A}	D _{8A} . . . D _{0A}	
			X...				...X	\overline{AF}_2 Offset ¹	

NOTES:

1. All four programmable-flag-offset values are initialized to eight (8) during a reset operation.
2. Parity Mode: Odd parity = HIGH; even parity = LOW. The parity mode is initialized to odd during a reset operation.
3. See Tables 5 and 6 and Figure 10 for the detailed format of the Control Register word.

Table 3b. LH543621 Resource-Register Programming

RESOURCE-REGISTER ADDRESS			RESOURCE-REGISTER CONTENTS						
A _{2A}	A _{1A}	A _{0A}							
			NORMAL FIFO OPERATION						
H	H	H	D _{35A}				D _{0A}		
			X...				...X		
			MAILBOX						
H	H	L	D _{35A}				D _{0A}		
			X...				...X		
			$\overline{AF}_2, \overline{AE}_2, \overline{AF}_1, \overline{AE}_1$ FLAG REGISTER (36-BIT MODE)⁴						
H	L	H	D _{35A} . . . D _{27A}	D _{26A} . . . D _{18A}	D _{17A} . . . D _{9A}	D _{8A} . . . D _{0A}			
			\overline{AF}_2 Offset ¹	\overline{AE}_2 Offset ¹	\overline{AF}_1 Offset ¹	\overline{AE}_1 Offset ¹			
			CONTROL REGISTER: FLAG SYNCHRONIZATION, PARITY CONFIGURATION						
H	L	L	D _{35A}	D _{18A}	D _{17A}	D _{9A}	D _{8A}	D _{1A}	D _{0A}
			X...	...X	Port B Control ³	Port A Control ³	PM ²		
			10-BIT \overline{AE}_1 FLAG OFFSET REGISTER						
L	H	H	D _{35A}			D _{10A}	D _{9A} . . . D _{0A}		
			X...			...X	\overline{AE}_1 Offset ¹		
			10-BIT \overline{AF}_1 FLAG OFFSET REGISTER						
L	H	L	D _{35A}			D _{10A}	D _{9A} . . . D _{0A}		
			X...			...X	\overline{AF}_1 Offset ¹		
			10-BIT \overline{AE}_2 FLAG OFFSET REGISTER						
L	L	H	D _{35A}			D _{10A}	D _{9A} . . . D _{0A}		
			X...			...X	\overline{AE}_2 Offset ¹		
			10-BIT \overline{AF}_2 FLAG OFFSET REGISTER						
L	L	L	D _{35A}			D _{10A}	D _{9A} . . . D _{0A}		
			X...			...X	\overline{AF}_2 Offset ¹		

NOTES:

- All four programmable-flag-offset values are initialized to eight (8) during a reset operation.
- Parity Mode: Odd parity = HIGH; even parity = LOW. The parity mode is initialized to odd during a reset operation.
- See Tables 5 and 6 and Figure 10 for the detailed format of the Control Register word.
- For 36-bit Flag Register Control word, with only 9 bits to program per flag offset: Offset is limited to a value of 511. If a greater value is desired, individual flag offset register programming is required.

Table 4a. LH543611 Flag Definition Table

FLAG	VALID READ CYCLES REMAINING				VALID WRITE CYCLES REMAINING			
	FLAG = LOW		FLAG = HIGH		FLAG = LOW		FLAG = HIGH	
	MIN	MAX	MIN	MAX	MIN	MAX	MIN	MAX
\overline{FF}	512	512	0	511	0	0	1	512
\overline{AF}	512-p	512	0	511-p	0	p	p + 1	512
\overline{HF}	257	512	0	256	0	255	256	512
\overline{AE}	0	q	q + 1	512	512-q	512	0	511-q
\overline{EF}	0	0	1	512	512	512	0	511

NOTE:

q = Programmable-Almost-Empty Offset value. (Default value: q = 8.)

p = Programmable-Almost-Full Offset value. (Default value: p = 8.)

Table 4b. LH543621 Flag Definition Table

FLAG	VALID READ CYCLES REMAINING				VALID WRITE CYCLES REMAINING			
	FLAG = LOW		FLAG = HIGH		FLAG = LOW		FLAG = HIGH	
	MIN	MAX	MIN	MAX	MIN	MAX	MIN	MAX
\overline{FF}	1024	1024	0	1023	0	0	1	1024
\overline{AF}	1024-p	1024	0	1023-p	0	p	p + 1	1024
\overline{HF}	513	1024	0	512	0	511	512	1024
\overline{AE}	0	q	q + 1	1024	1024-q	1024	0	1023-q
\overline{EF}	0	0	1	1024	1024	1024	0	1023

NOTE:

q = Programmable-Almost-Empty Offset value. (Default value: q = 8.)

p = Programmable-Almost-Full Offset value. (Default value: p = 8.)

Table 5. Control-Register Format

PORT	COMMAND REGISTER BITS	CODE	VALUE AFTER RESET	FLAG AFFECTED, IF ANY	DESCRIPTION	NOTES	
A, B	00	L	H	$\overline{PF}_A, \overline{PF}_B$	EVEN parity in effect.	A correct 9-bit byte has an even number of ones.	
		H			ODD parity in effect.	A correct 9-bit byte has an odd number of ones.	
A	01	L	L	-	Disable Port A parity generation.	No overwriting of parity bits.	
		H			Enable Port A parity generation.	Parity bit over eight least-significant bits of each byte is overwritten into the most-significant bit of that byte.	
	02	L	L	\overline{PF}_A	Port A parity-error flag operates 'flowthrough.'	\overline{PF}_A is subject to transient glitches while data bus is changing.	
		H			Port A parity-error flag is latched by CK_A .	\overline{PF}_A is subject to transient glitches while data bus is changing.	
	03	L	L	\overline{EF}_2	Set by $\uparrow CK_A$, reset by $\uparrow CK_B$.	Asynchronous flag clocking.	
		H			Set and reset by $\uparrow CK_A$.	Synchronous flag clocking.	
	04	L	L	\overline{AE}_2	Set by $\uparrow CK_A$, reset by $\uparrow CK_B$.	Asynchronous flag clocking.	
		H			Set and reset by $\uparrow CK_B$.	Synchronous flag clocking.	
	05, 06	LL	LL	\overline{HF}_1	Set by $\uparrow CK_A$, reset by $\uparrow CK_B$.	Asynchronous flag clocking.	
		LH			Set and reset by $\uparrow CK_B$.	Synchronous flag clocking by Port B clock.	
		HL, HH			Set and reset by $\uparrow CK_A$.	Synchronous flag clocking by Port A clock.	
	07	L	L	\overline{AF}_1	Set by $\uparrow CK_A$, reset by $\uparrow CK_B$.	Asynchronous flag clocking.	
		H			Set and reset by $\uparrow CK_A$.	Synchronous flag clocking.	
	08	L	L	\overline{FF}_1	Set by $\uparrow CK_A$, reset by $\uparrow CK_B$.	Asynchronous flag clocking.	
		H			Set and reset by $\uparrow CK_A$.	Synchronous flag clocking.	
	B	09	L	L	\overline{PF}_B	Parity check computed over all four bytes of each word.	Full-word parity-error indication regardless of $WS_1 - WS_0$ setting.
			H			Parity check computed over half-word or single-byte according to $WS_1 - WS_0$ setting.	Full-word, half word, or single-byte parity-error indication according to $WS_1 - WS_0$ setting.
		10	L	L	-	Disable Port B parity generation.	No overwriting of parity bits.
H			Enable Port B parity generation.			Parity bit over eight least-significant bits of each byte is overwritten into the most-significant bit of that byte.	
11		L	L	\overline{PF}_B	Port B parity-error flag operates 'flowthrough.'	\overline{PF}_B is subject to transient glitches while data bus is changing.	
		H			Port B parity-error flag is latched by CK_B .	\overline{PF}_B remains steady until its value should change.	
12		L	L	\overline{EF}_1	Set by $\uparrow CK_B$, reset by $\uparrow CK_A$.	Asynchronous flag clocking.	
		H			Set and reset by $\uparrow CK_B$.	Synchronous flag clocking.	
13		L	L	\overline{AE}_1	Set by $\uparrow CK_B$, reset by $\uparrow CK_A$.	Asynchronous flag clocking.	
		H			Set and reset by $\uparrow CK_A$.	Synchronous flag clocking.	
14, 15		LL	LL	\overline{HF}_2	Set and reset by $\uparrow CK_A$.	Asynchronous flag clocking.	
		LH			Set and reset by $\uparrow CK_A$.	Synchronous flag clocking by Port A clock.	
	HL, HH	Set and reset by $\uparrow CK_A$.			Synchronous flag clocking by Port B clock.		

Table 5. Control-Register Format (cont'd)

PORT	COMMAND REGISTER BITS	CODE	VALUE AFTER RESET	FLAG AFFECTED, IF ANY	DESCRIPTION	NOTES
B	16	L	L	\overline{AF}_2	Set by $\uparrow CK_B$, reset by $\uparrow CK_A$.	Asynchronous flag clocking.
		H			Set and reset by $\uparrow CK_B$.	Synchronous flag clocking.
	17	L	L	\overline{FF}_2	Set by $\uparrow CK_B$, reset by $\uparrow CK_A$.	Asynchronous flag clocking.
		H			Set and reset by $\uparrow CK_B$.	Synchronous flag clocking.

Table 6. Controllable Functions

TYPE	DESCRIPTION	CONTROL-REGISTER BIT	
		PORT A	PORT B
Parity	Even/Odd	0 ¹	0 ¹
	Policy for 9/18-Bit Word-Width Selection	–	9
	Generation: Enable/Disable	1	10
	Flag Behavior: Latched/Flowthrough	2	11
Flag Synchronization	\overline{EF} Synchronous/Asynchronous	3	12
	\overline{AE} Synchronous/Asynchronous	4	13
	\overline{HF} Synchronous-With-Write/Synchronous-With-Read	5–6	14–15
	\overline{AF} Synchronous/Asynchronous	7	16
	\overline{FF} Synchronous/Asynchronous	8	17

NOTE:

1. LH5420/LH543601 also have this Control-Register function. The same Control-Register bit, bit 00, controls both Port A and Port B functionality.

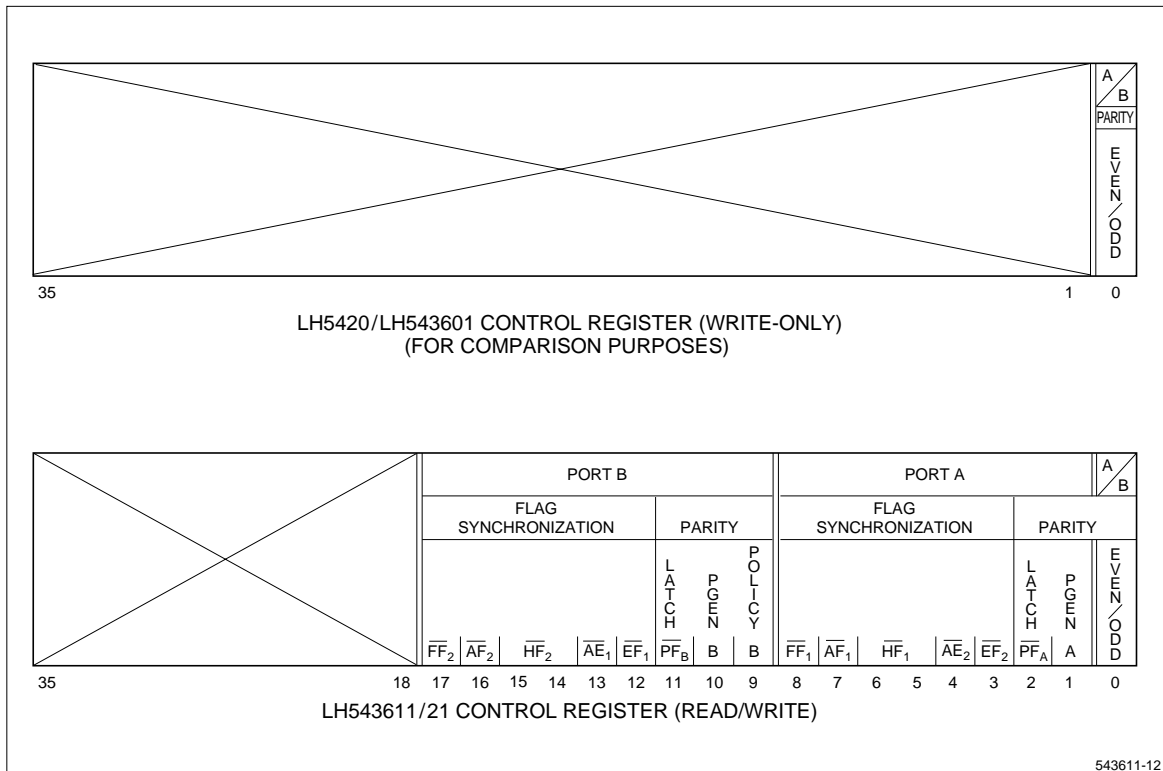

Figure 10. LH5420/LH543601 and LH543611/21 Control-Register Formats

TIMING DIAGRAMS

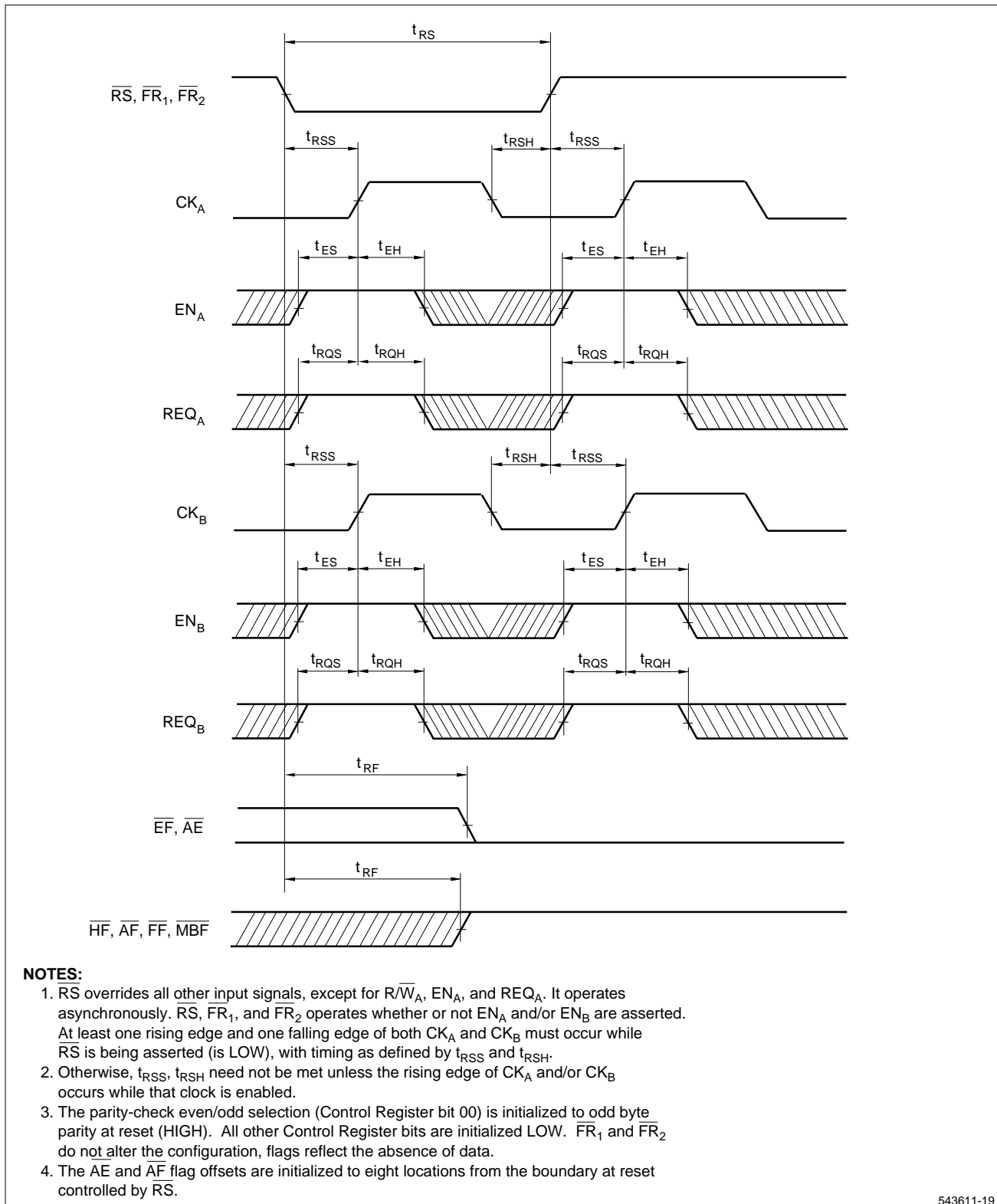
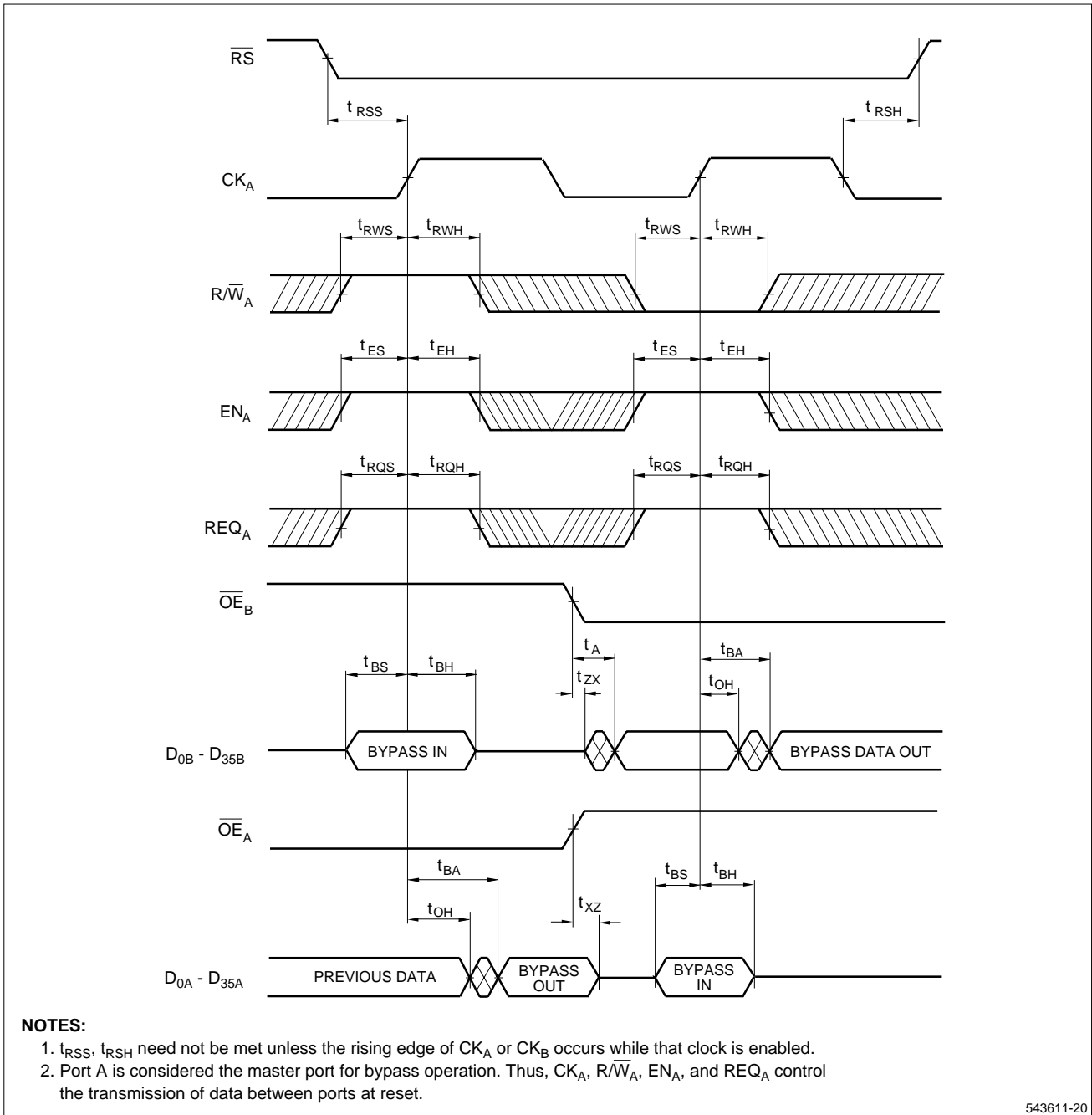

Figure 11. Reset Timing

543611-19

TIMING DIAGRAMS (cont'd)



543611-20

Figure 12. Data Bypass Timing

TIMING DIAGRAMS (cont'd)

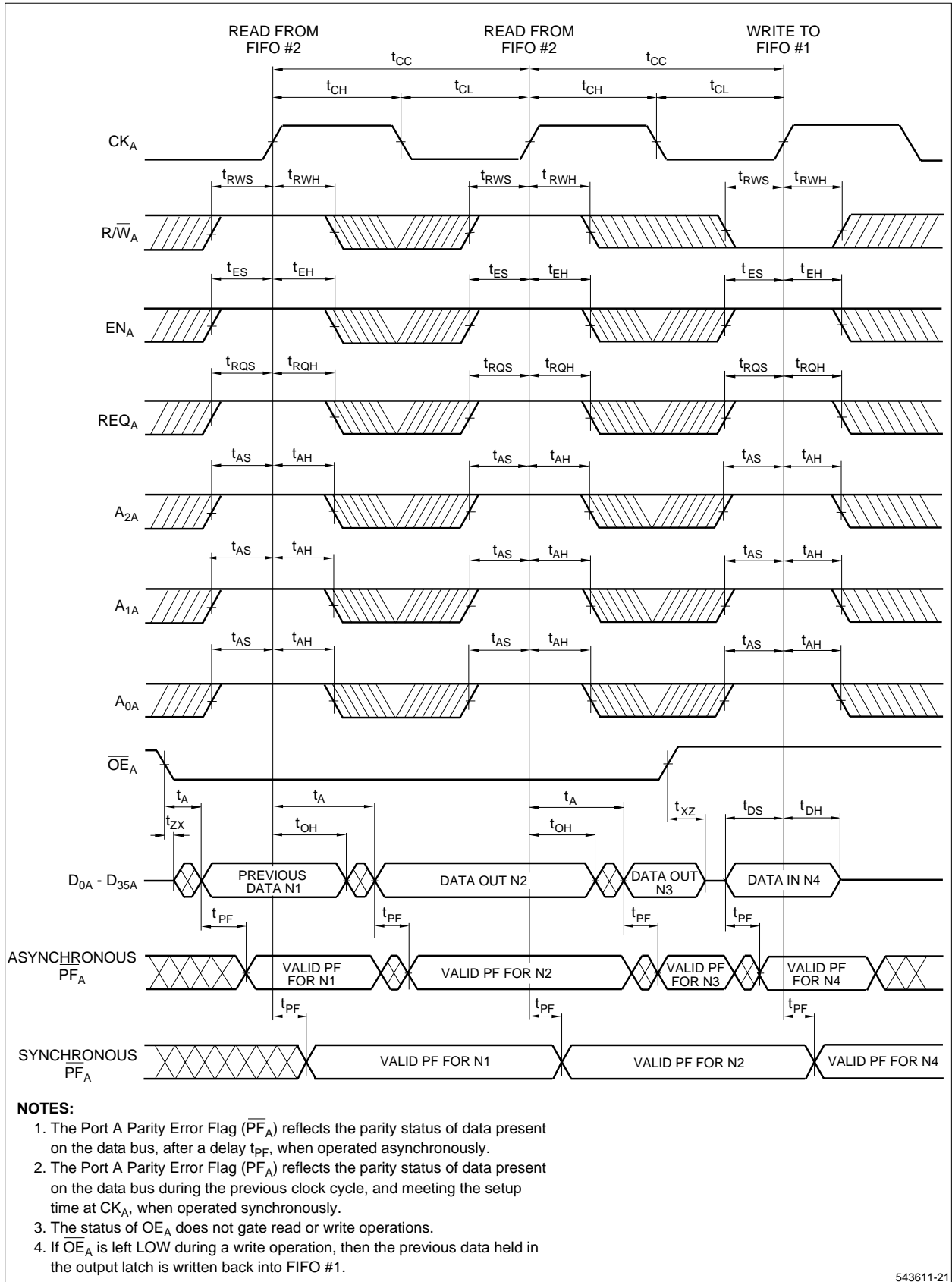

543611-21

Figure 13. Port A FIFO Read/Write

TIMING DIAGRAMS (cont'd)

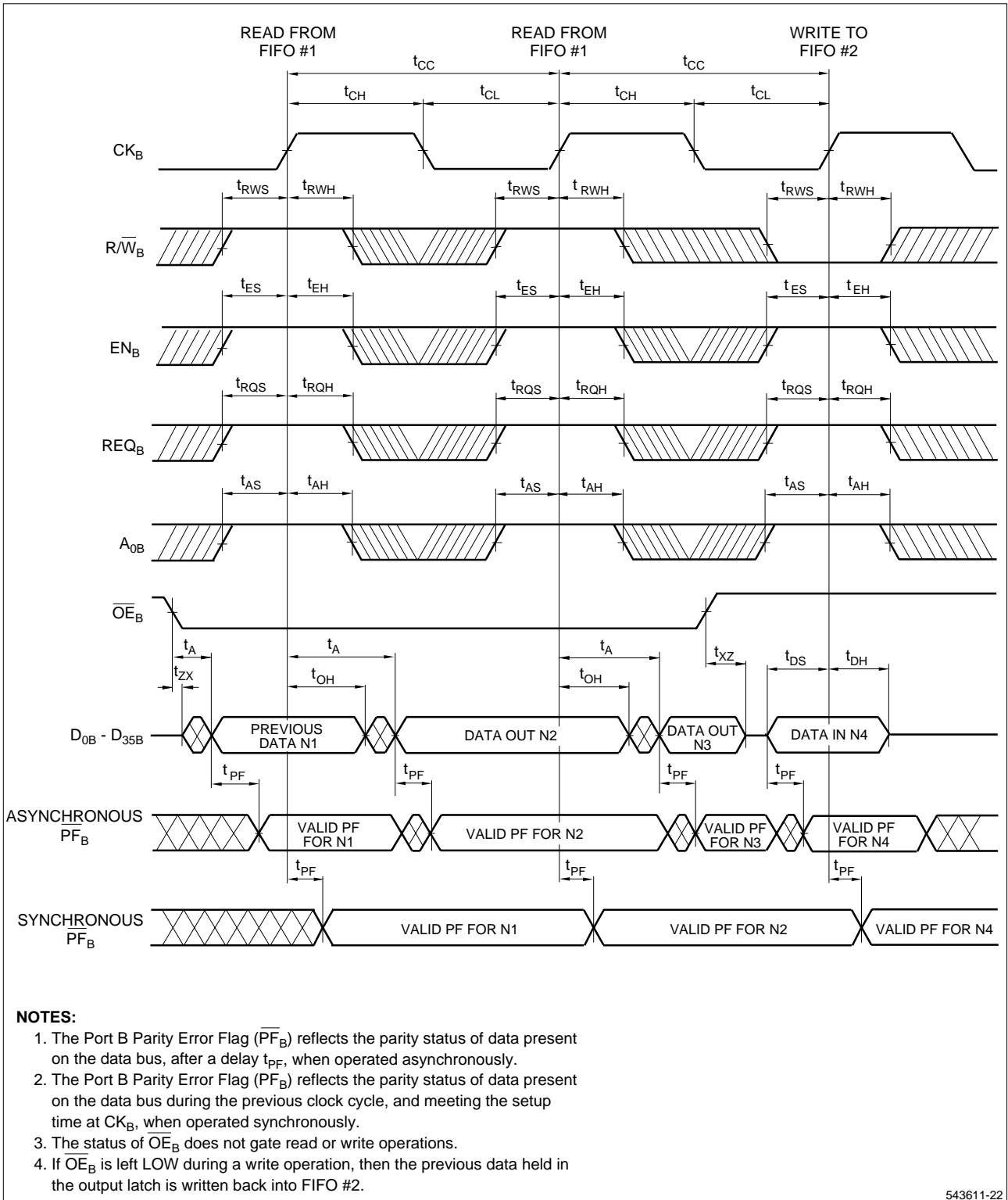

543611-22

Figure 14. Port B FIFO Read/Write

TIMING DIAGRAMS (cont'd)

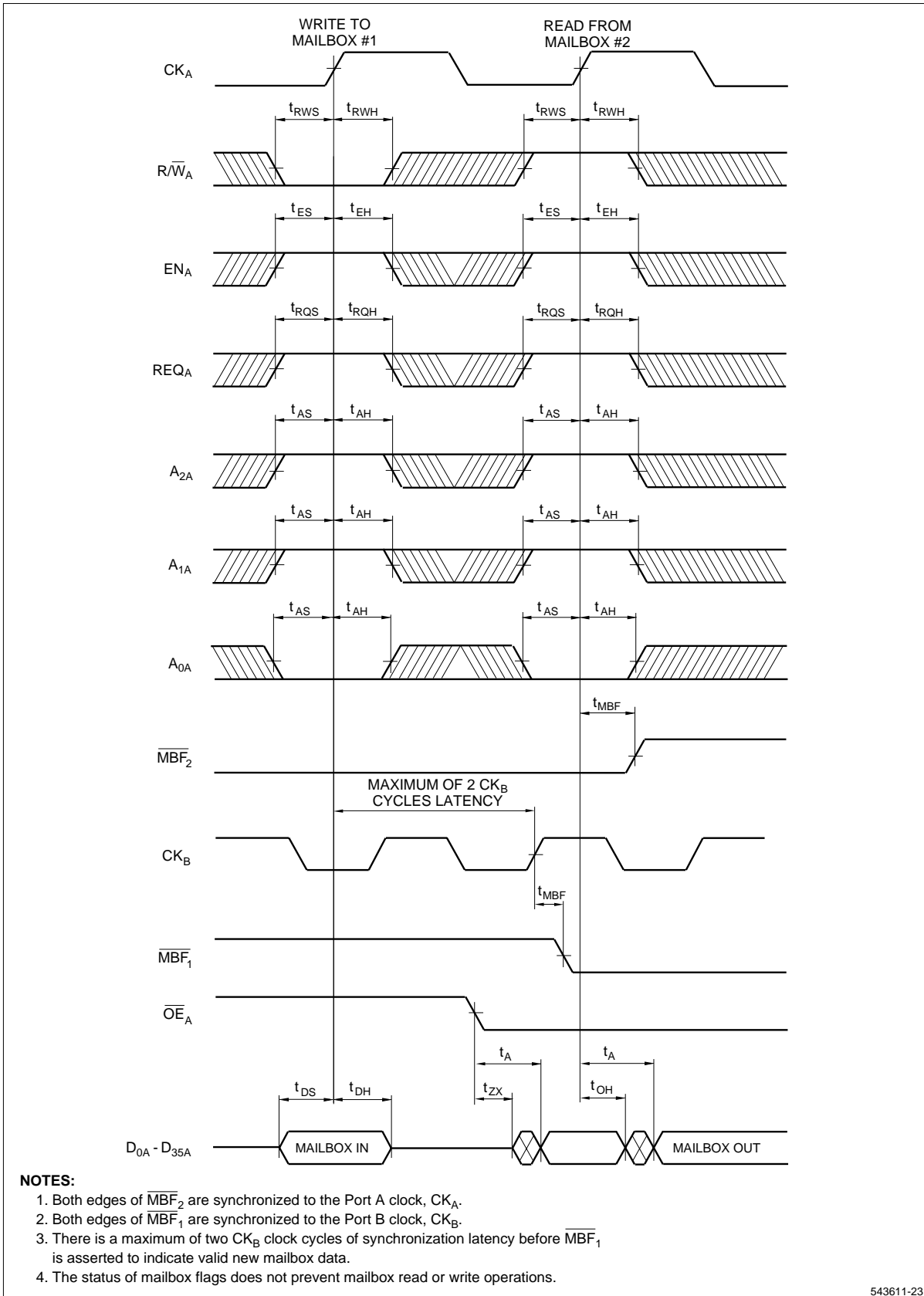
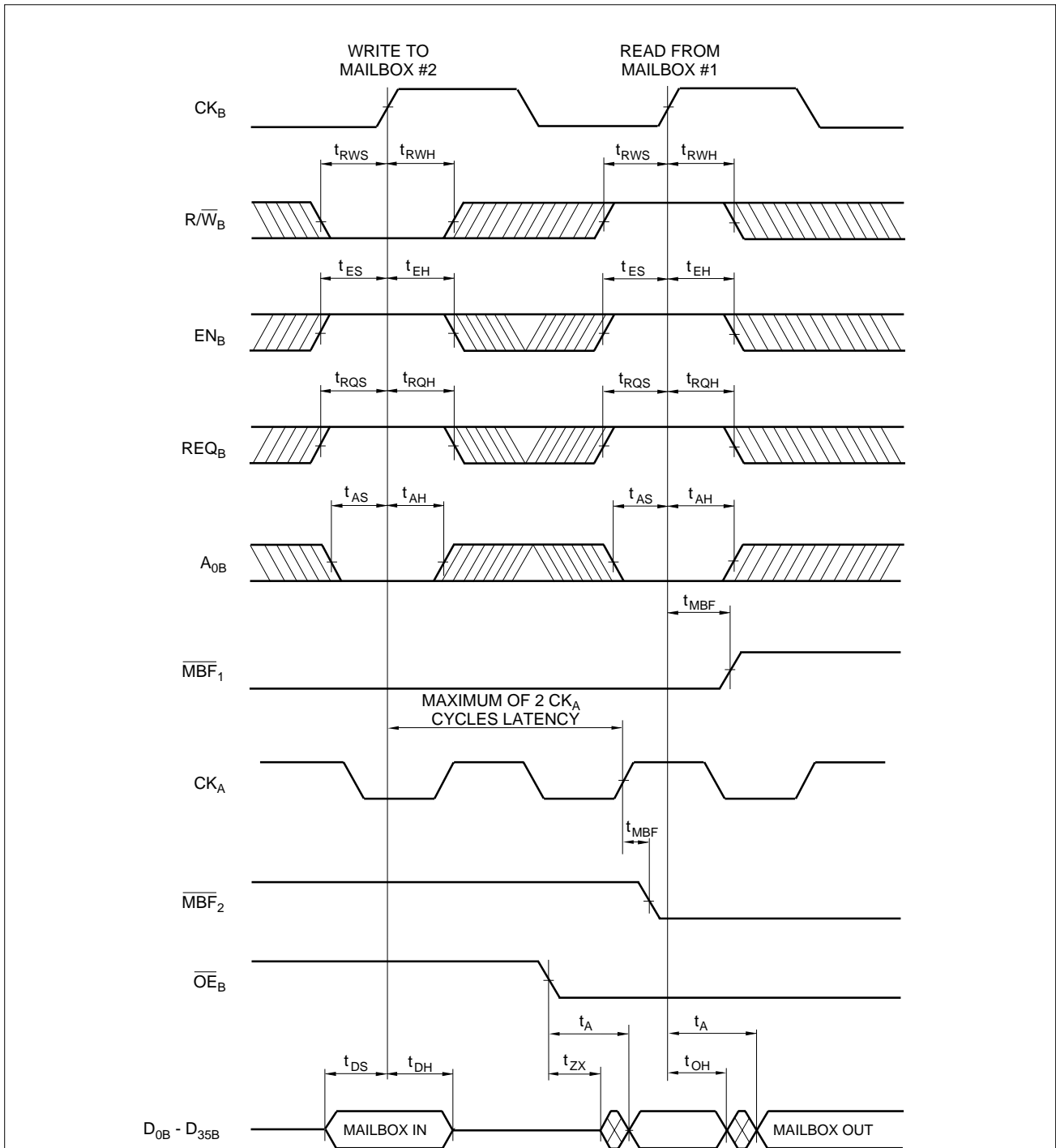

Figure 15. Port A Mailbox Access

TIMING DIAGRAMS (cont'd)



NOTES:

1. Both edges of \overline{MBF}_2 are synchronized to the Port A clock, CK_A.
2. Both edges of \overline{MBF}_1 are synchronized to the Port B clock, CK_B.
3. There is a maximum of two CK_A clock cycles of synchronization latency before \overline{MBF}_2 is asserted to indicate valid new mailbox data.
4. The status of mailbox flags does not prevent mailbox read or write operations.

543611-24

Figure 16. Port B Mailbox Access

TIMING DIAGRAMS (cont'd)

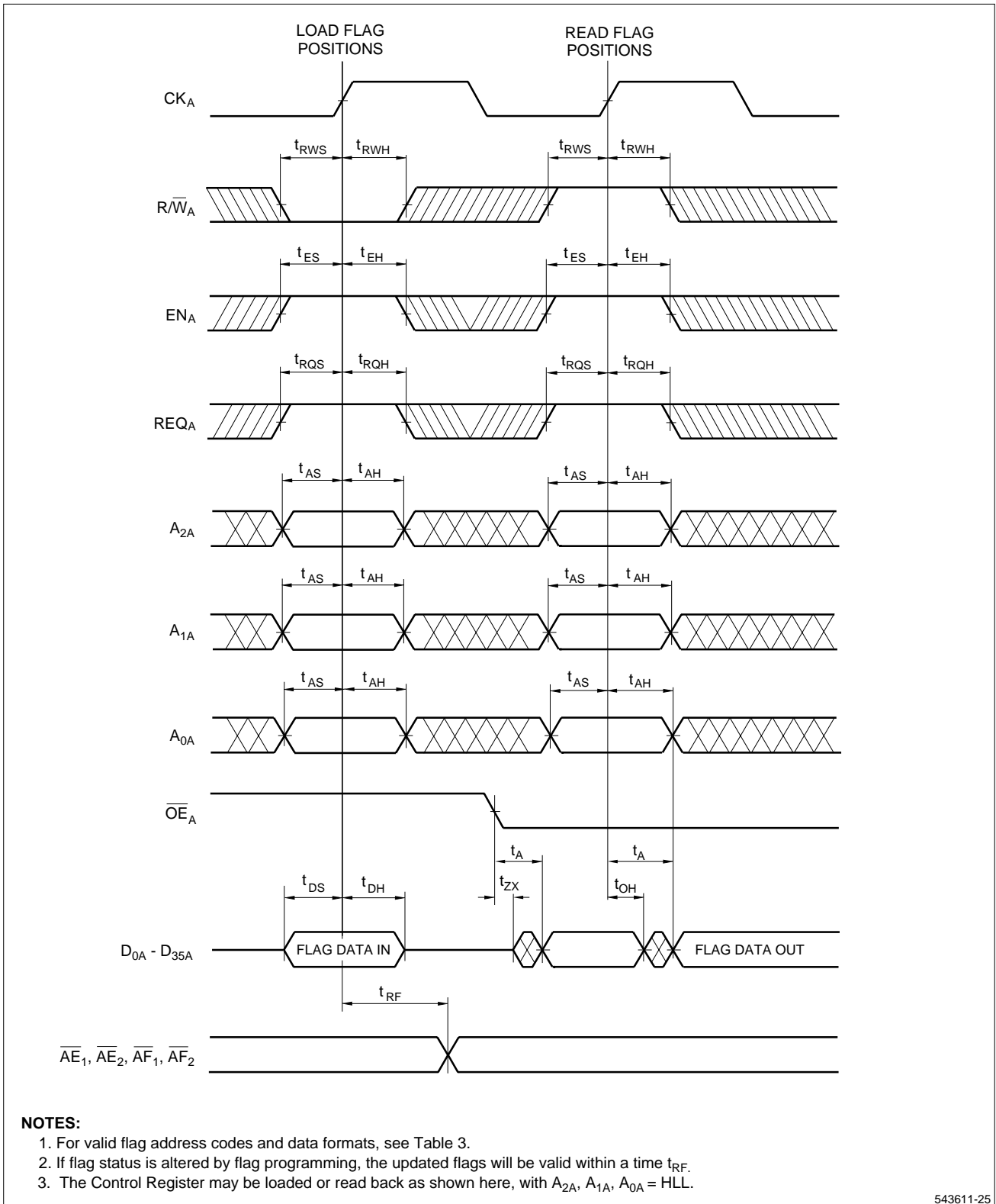
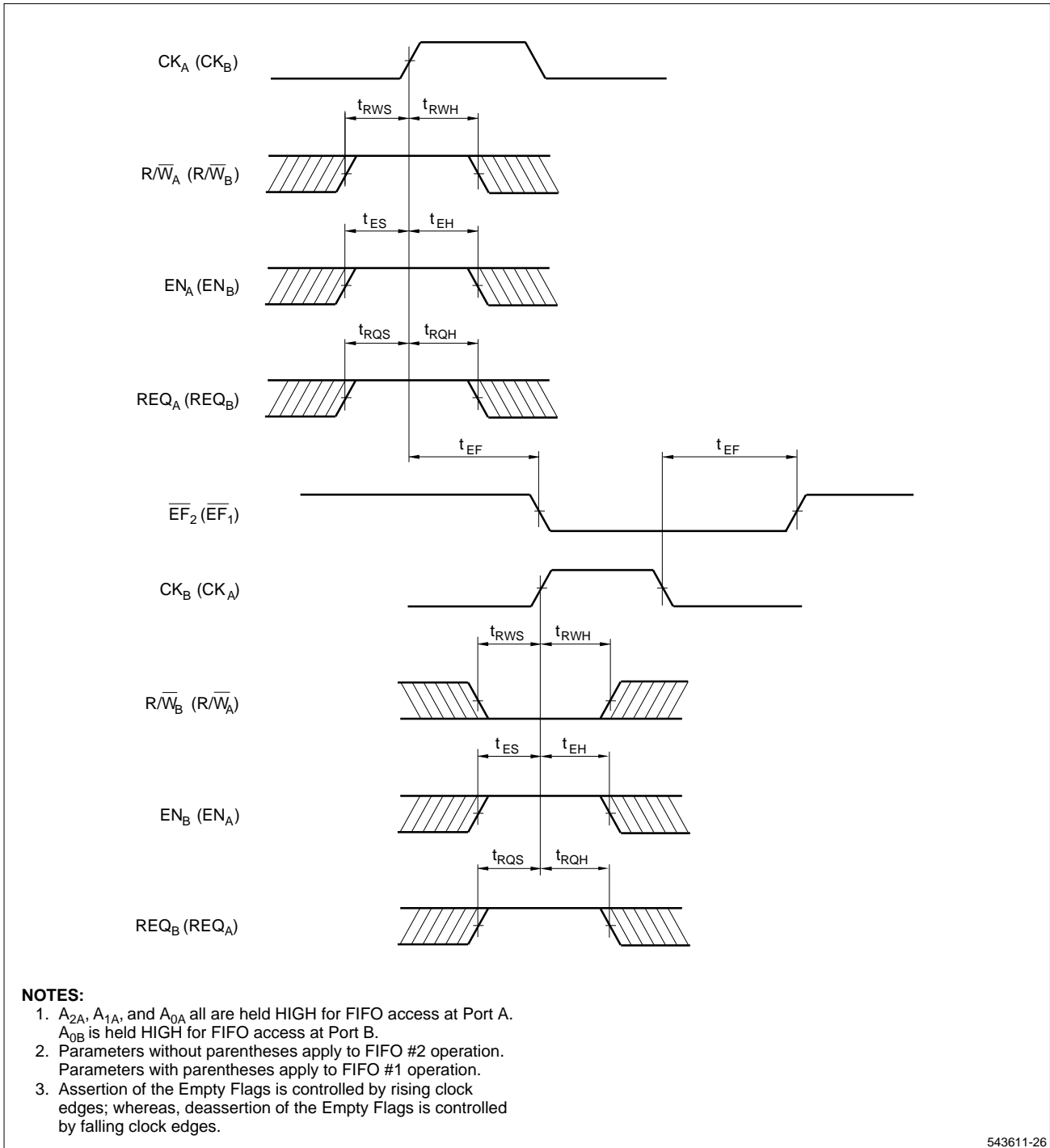

Figure 17. Flag Programming

TIMING DIAGRAMS (cont'd)



543611-26

Figure 18. Empty Flag Timing, When Asynchronous

TIMING DIAGRAMS (cont'd)

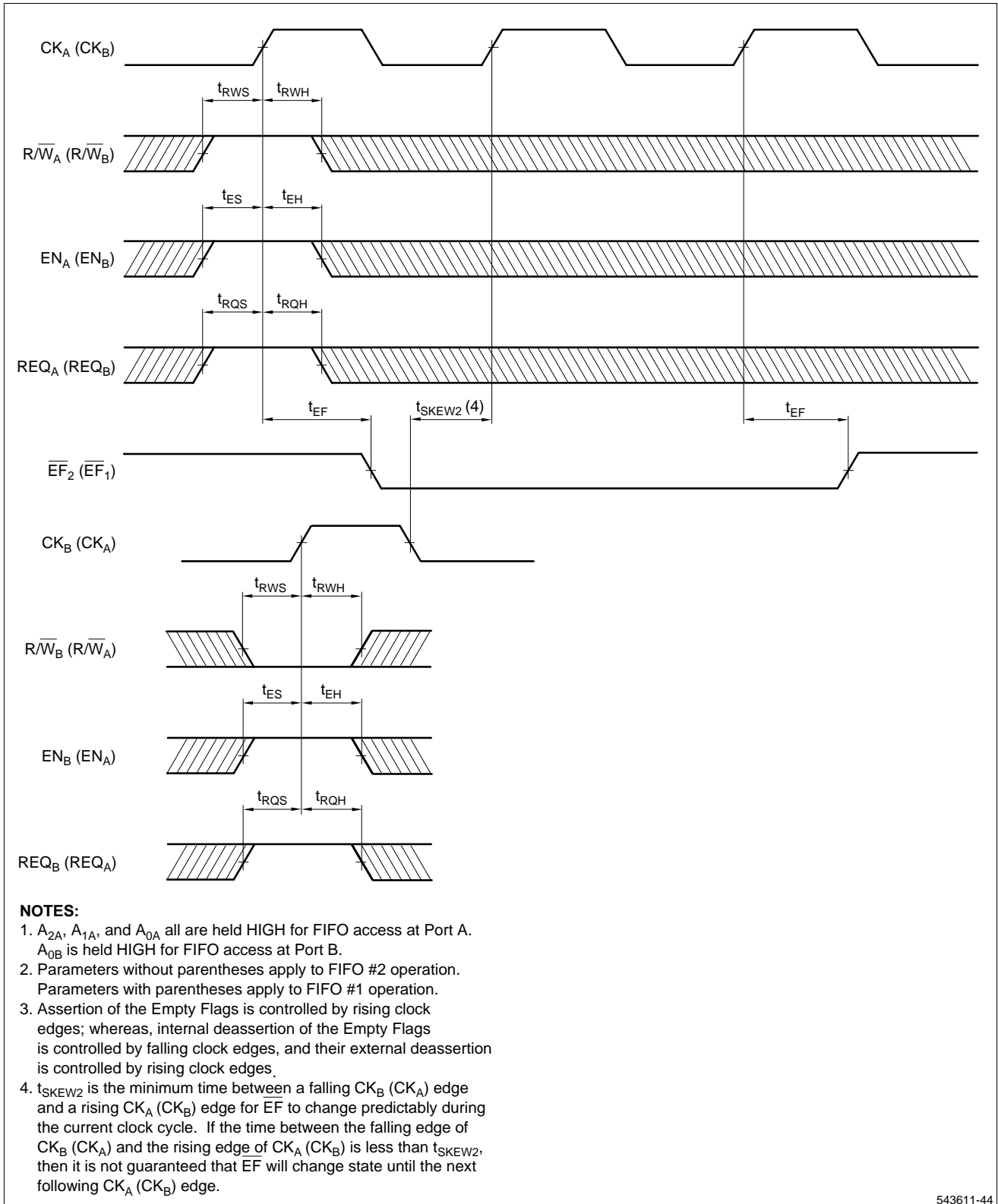

Figure 19. Empty Flag Timing, When Synchronous

TIMING DIAGRAMS (cont'd)

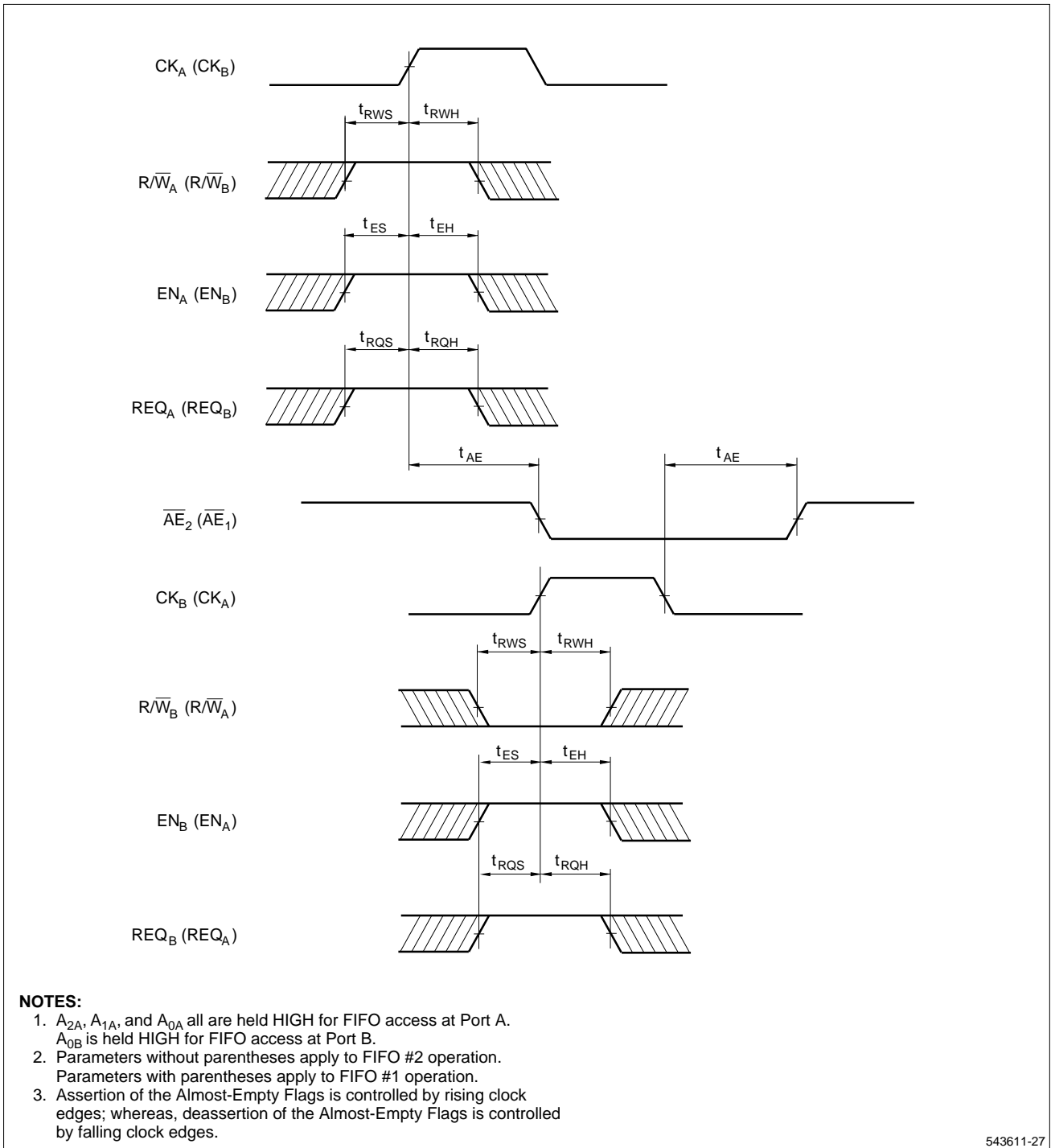

Figure 20. Almost-Empty Flag Timing, When Asynchronous

TIMING DIAGRAMS (cont'd)

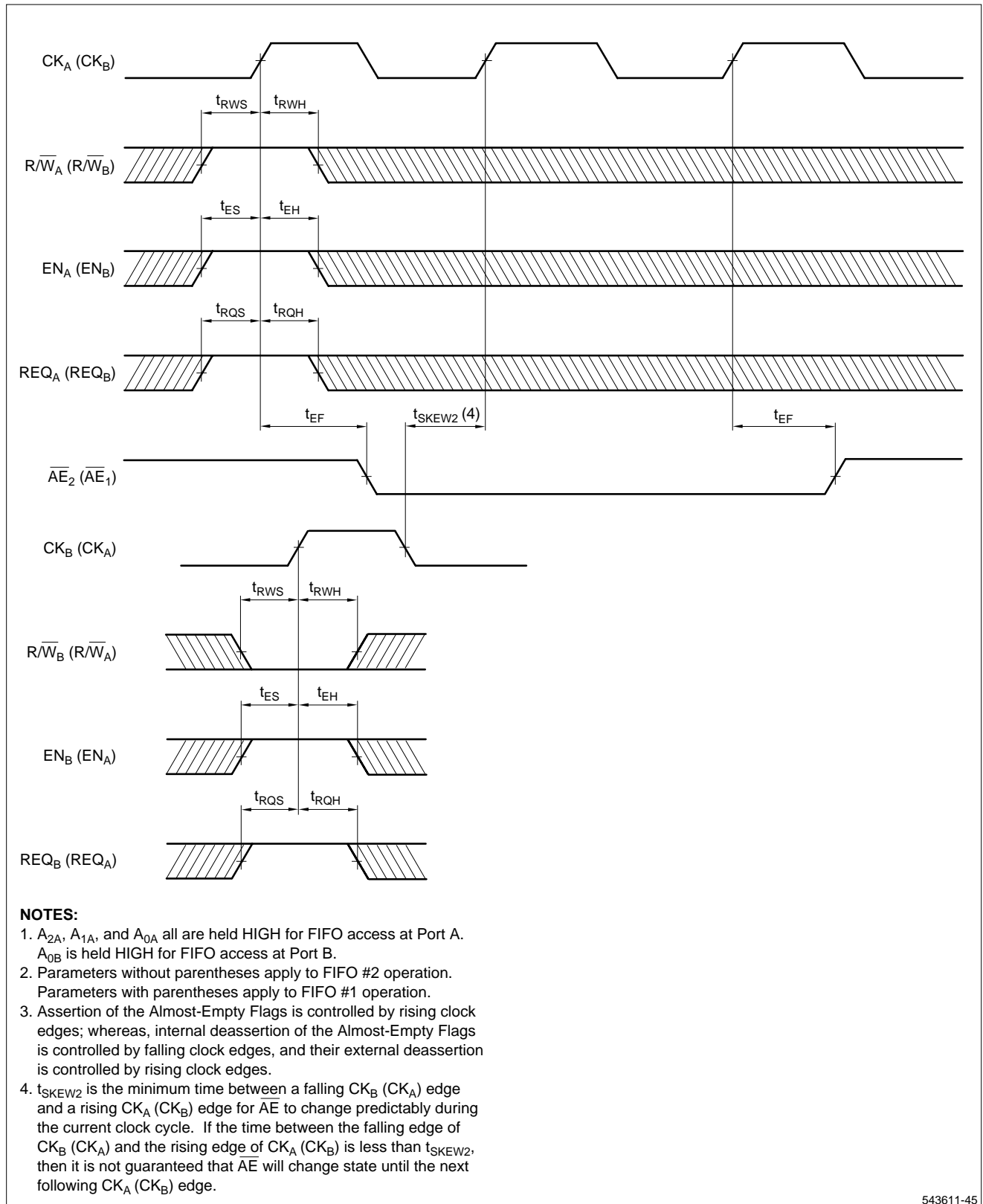
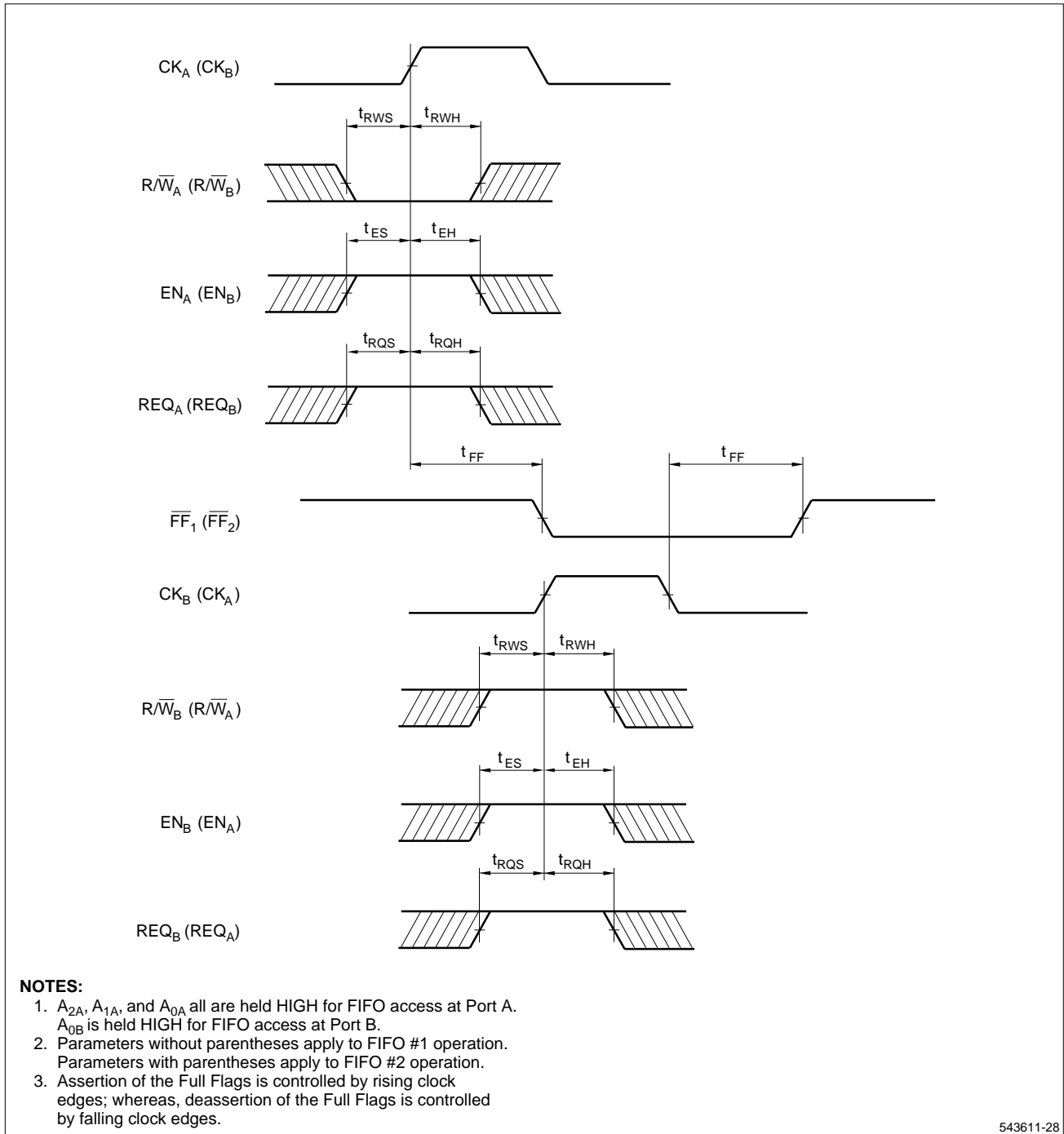

Figure 21. Almost-Empty Flag Timing, When Synchronous

TIMING DIAGRAMS (cont'd)



543611-28

Figure 22. Full Flag Timing, When Asynchronous

TIMING DIAGRAMS (cont'd)

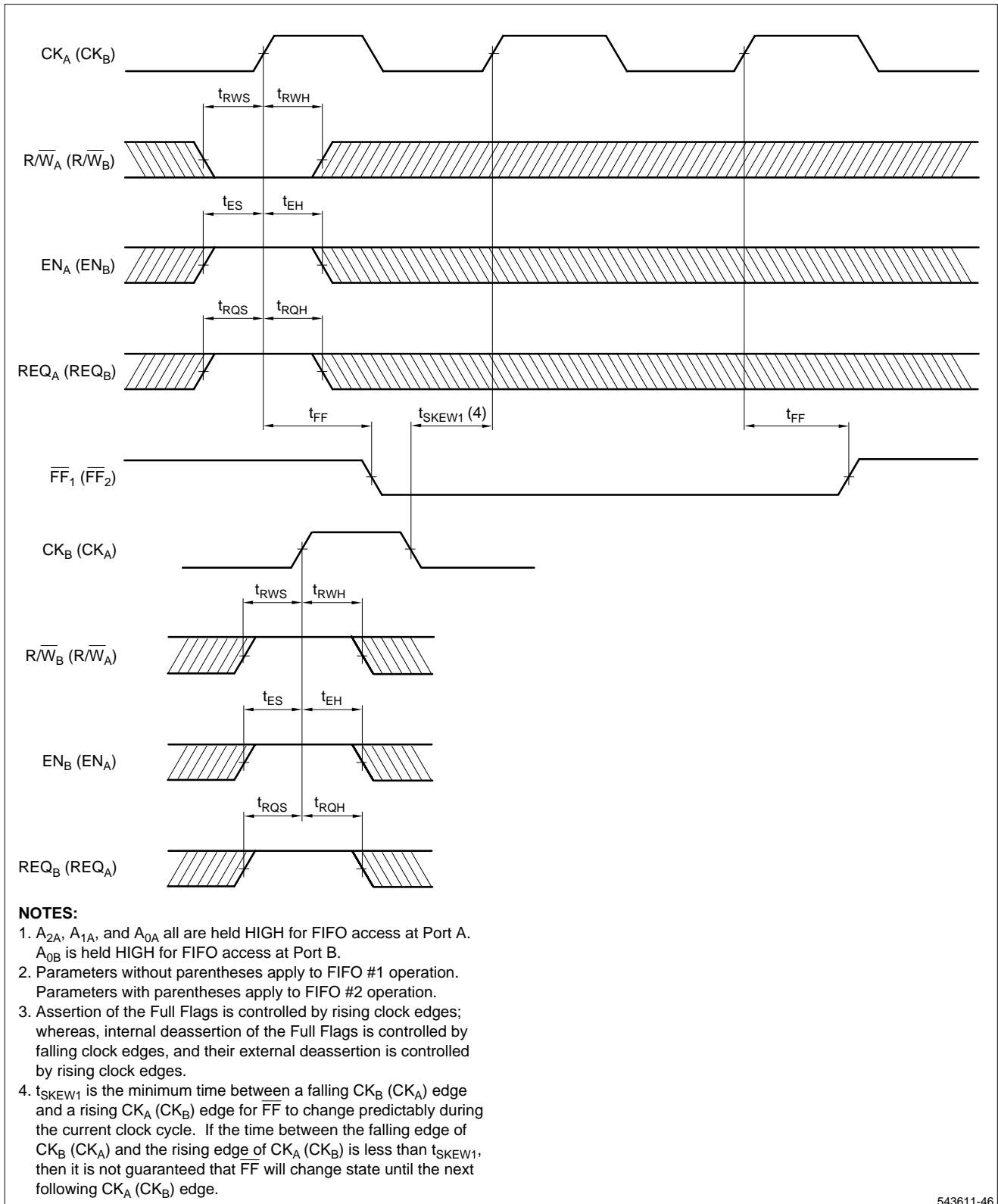

543611-46

Figure 23. Full Flag Timing, When Synchronous

TIMING DIAGRAMS (cont'd)

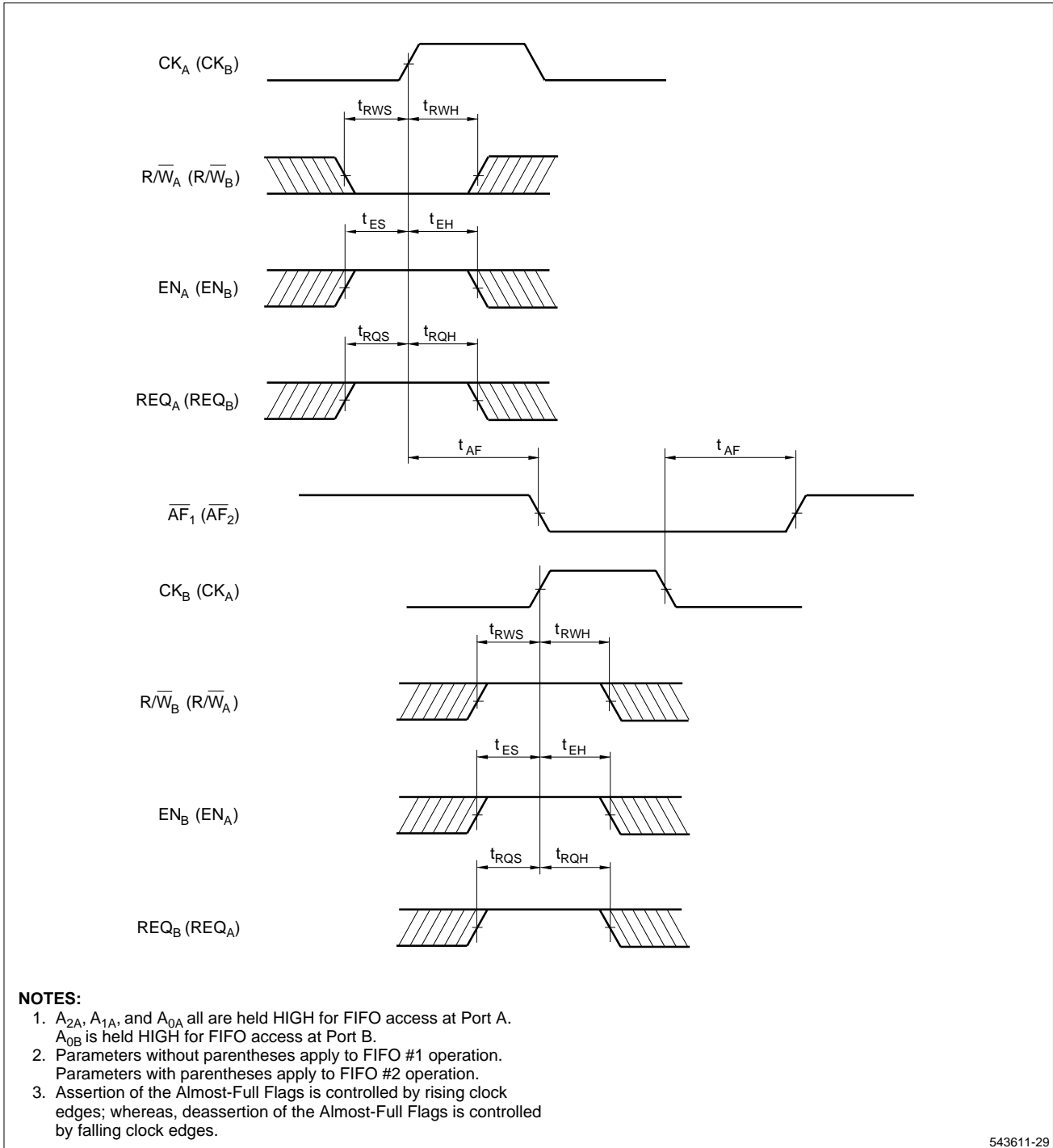

543611-29

Figure 24. Almost-Full Flag Timing, When Asynchronous

TIMING DIAGRAMS (cont'd)

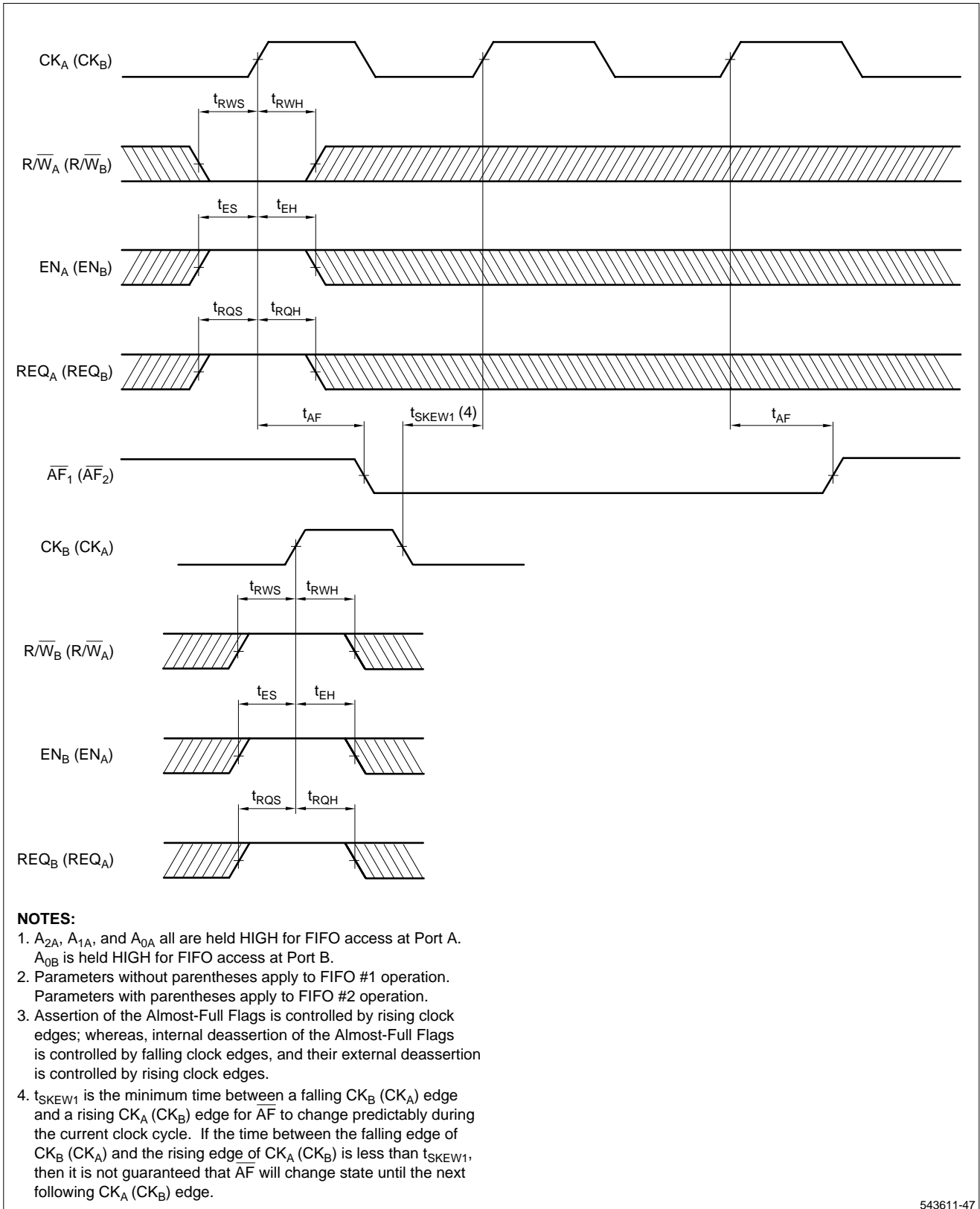

Figure 25. Almost-Full Flag Timing, When Synchronous

TIMING DIAGRAMS (cont'd)

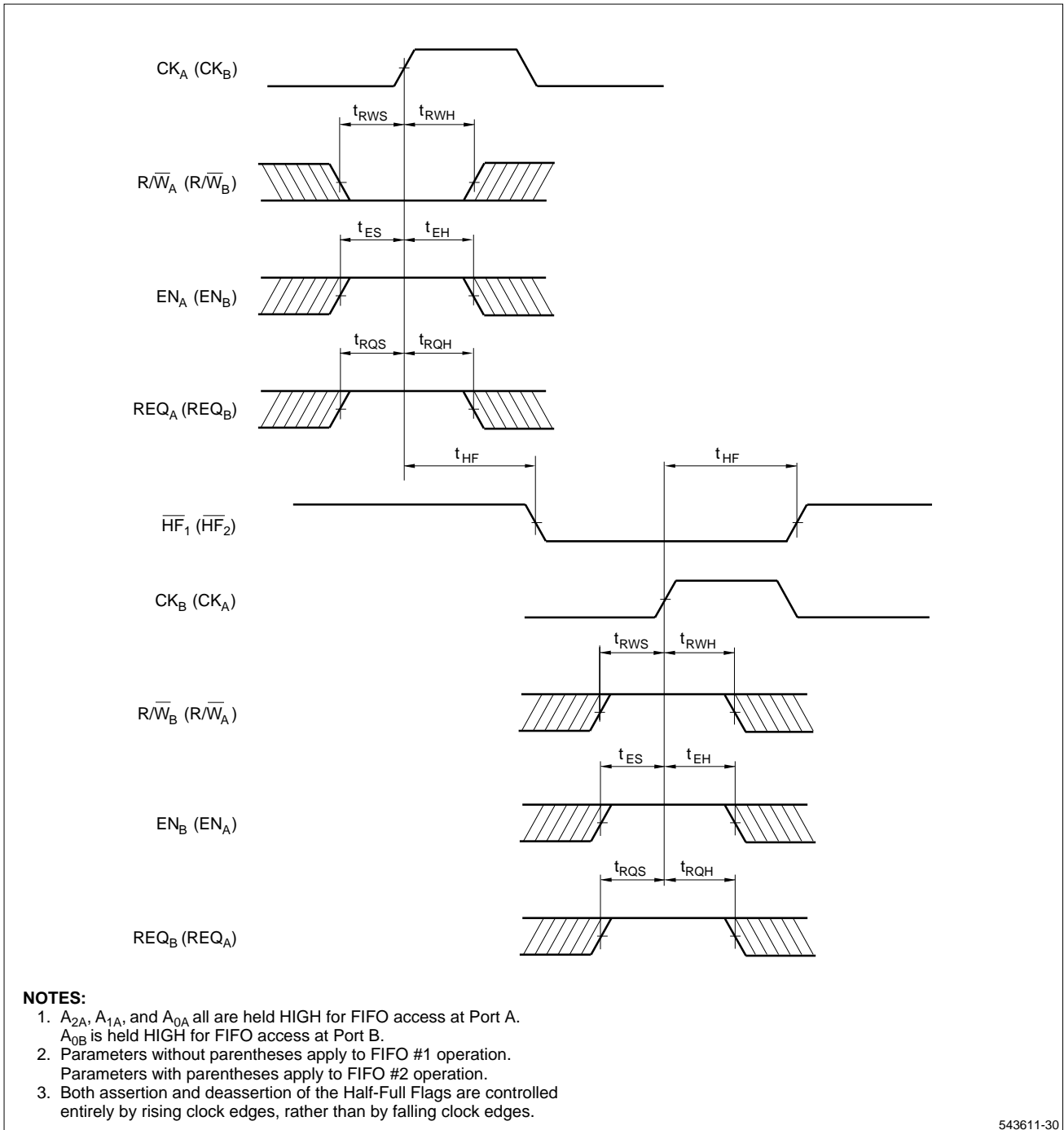

Figure 26. Half-Full Flag Timing, When Asynchronous

TIMING DIAGRAMS (cont'd)

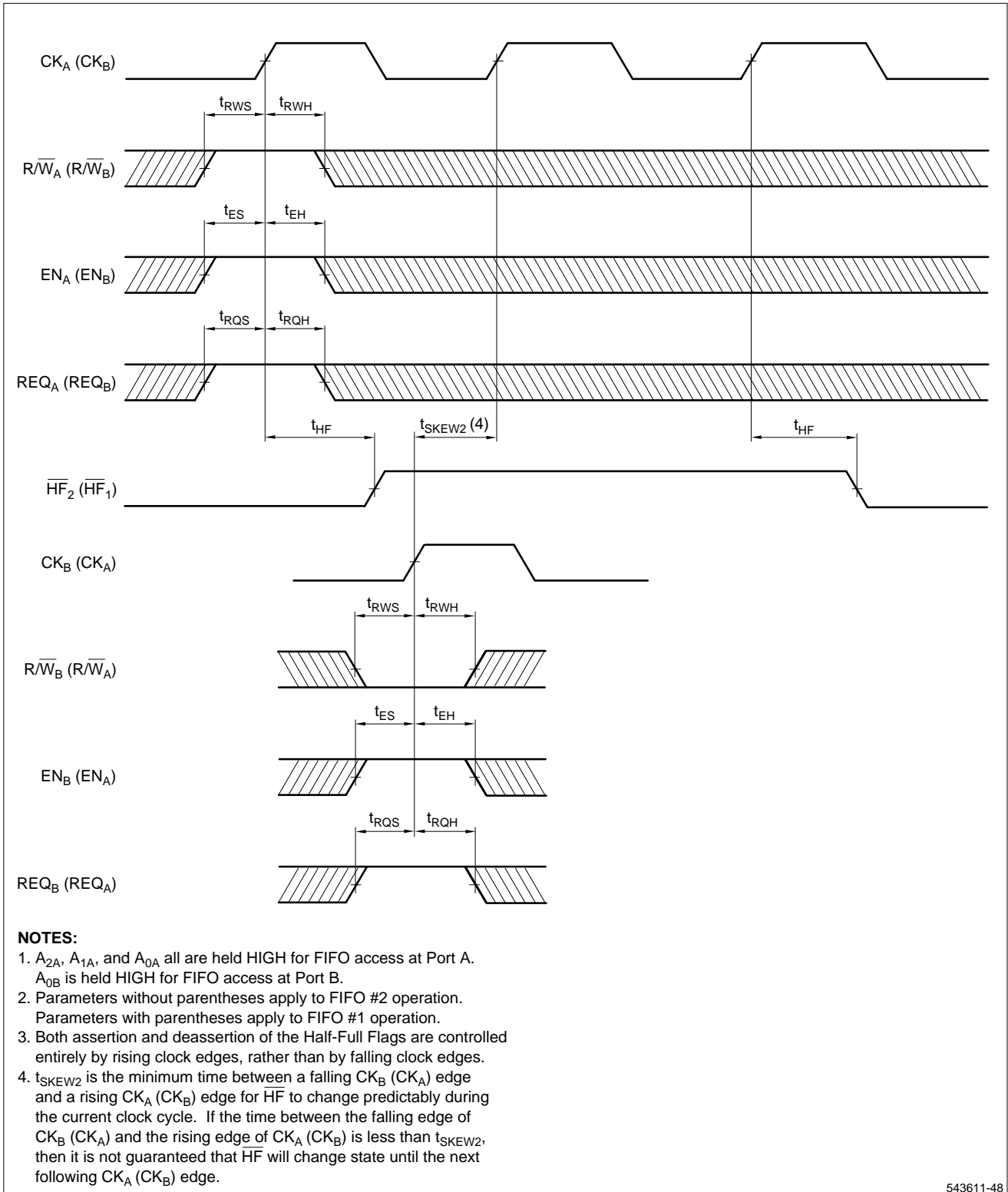

Figure 27. Half-Full Flag Timing, When Synchronized to a Port Clock Doing Reading

TIMING DIAGRAMS (cont'd)

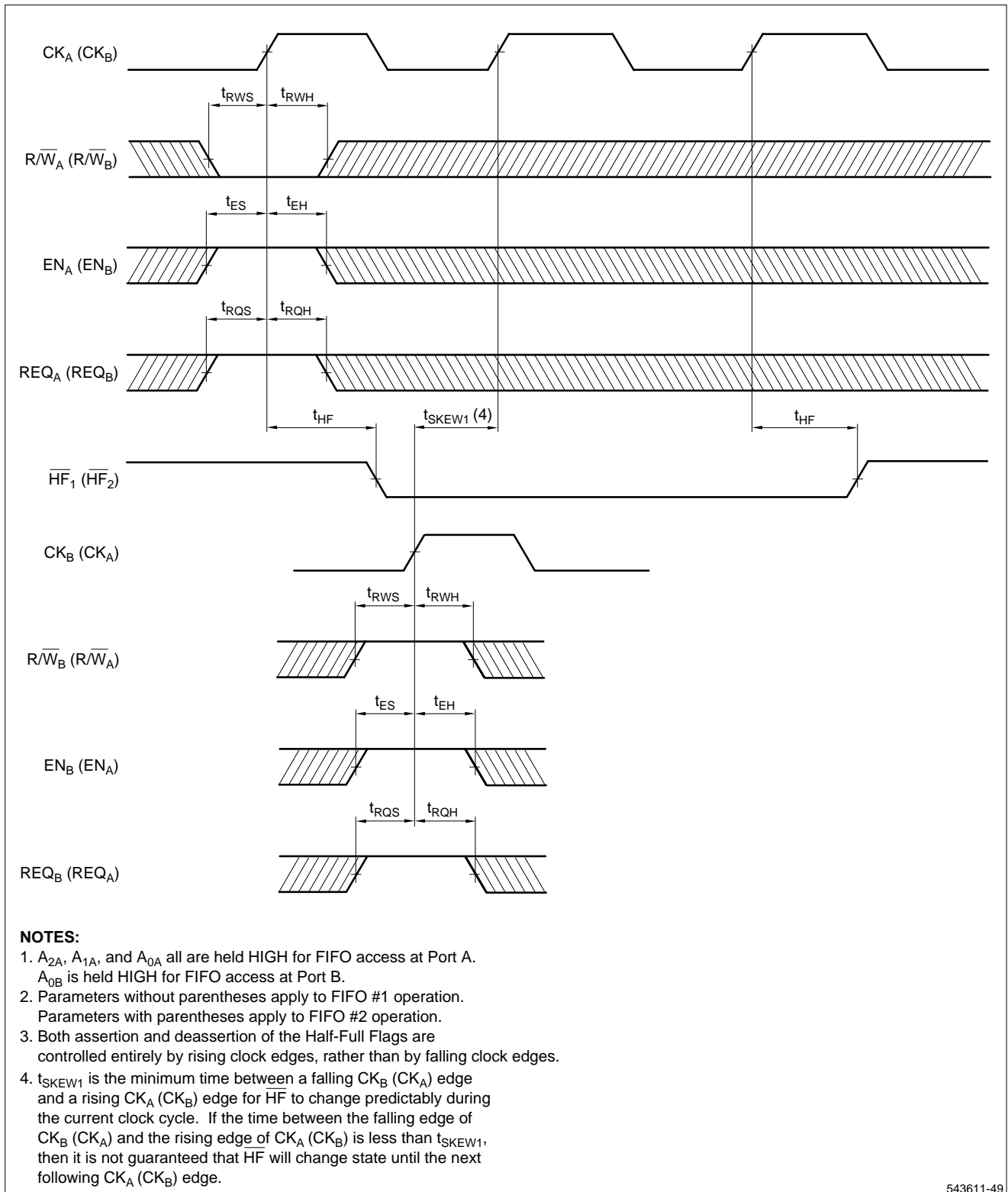
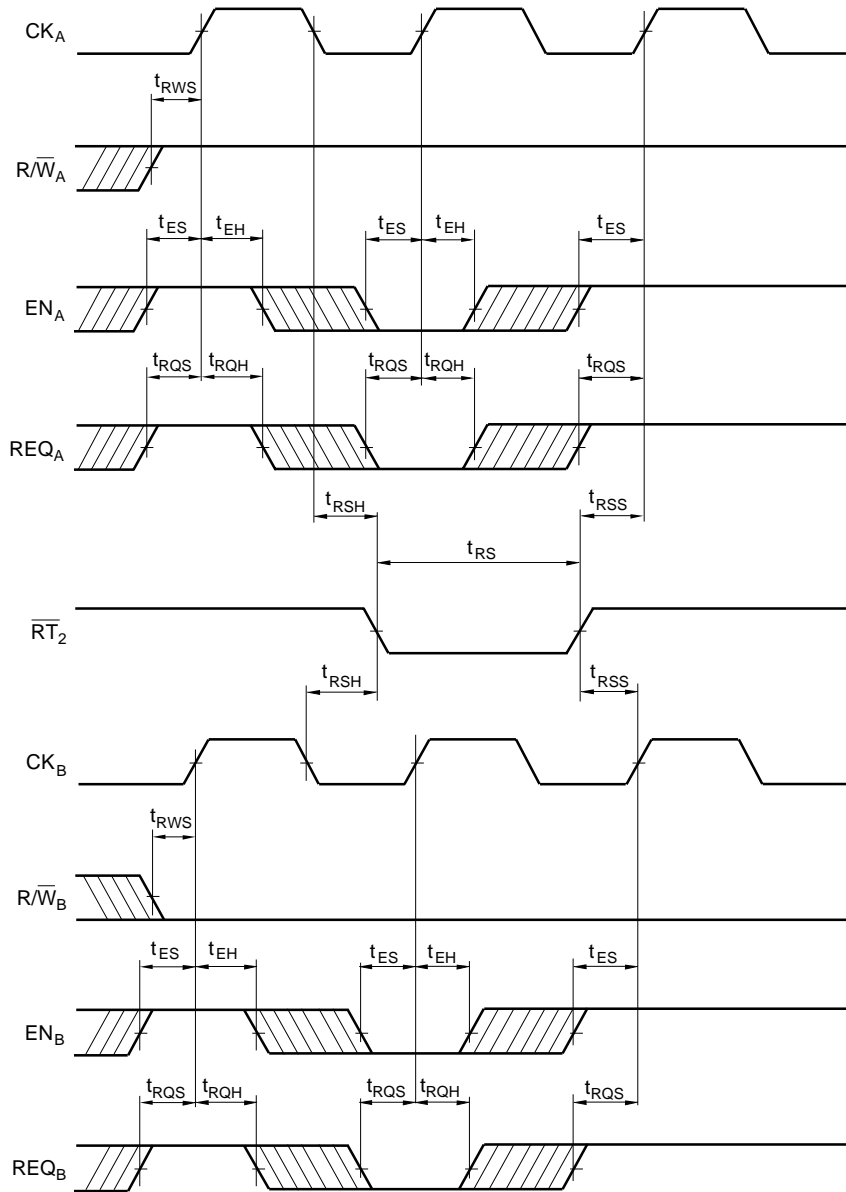

Figure 28. Half-Full Flag Timing, When Synchronized to a Port Clock Doing Writing

TIMING DIAGRAMS (cont'd)



NOTES:

1. t_{RSS} and t_{RSH} need not be met unless a rising edge of CK_A or CK_B occurs while that clock is enabled.
2. t_{RSS} is the time needed to deassert RT₂ before returning to a normal FIFO cycle.
3. t_{RSH} is the time needed before asserting RT₂ after a normal FIFO cycle.
4. Read and write operations to FIFO #2 should be disabled while RT₂ is being asserted.

543611-31

Figure 29. FIFO #2 Retransmit

TIMING DIAGRAMS (cont'd)

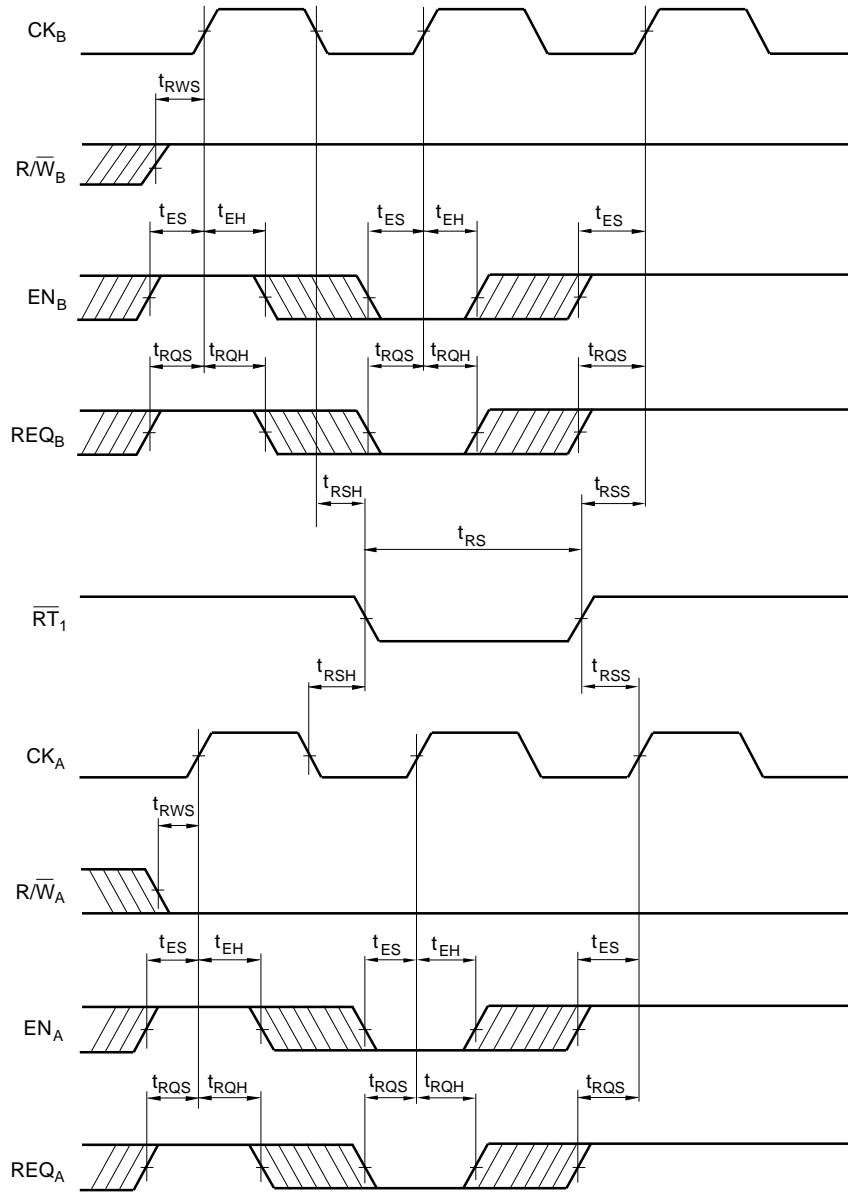

NOTES:

1. t_{RSS} and t_{RSH} need not be met unless a rising edge of CK_A or CK_B occurs while that clock is enabled.
2. t_{RSS} is the time needed to deassert \bar{RT}_1 before returning to a normal FIFO cycle.
3. t_{RSH} is the time needed before asserting \bar{RT}_1 after a normal FIFO cycle.
4. Read and write operations to FIFO #1 should be disabled while \bar{RT}_1 is being asserted.

543611-32

Figure 30. FIFO #1 Retransmit

TIMING DIAGRAMS (cont'd)

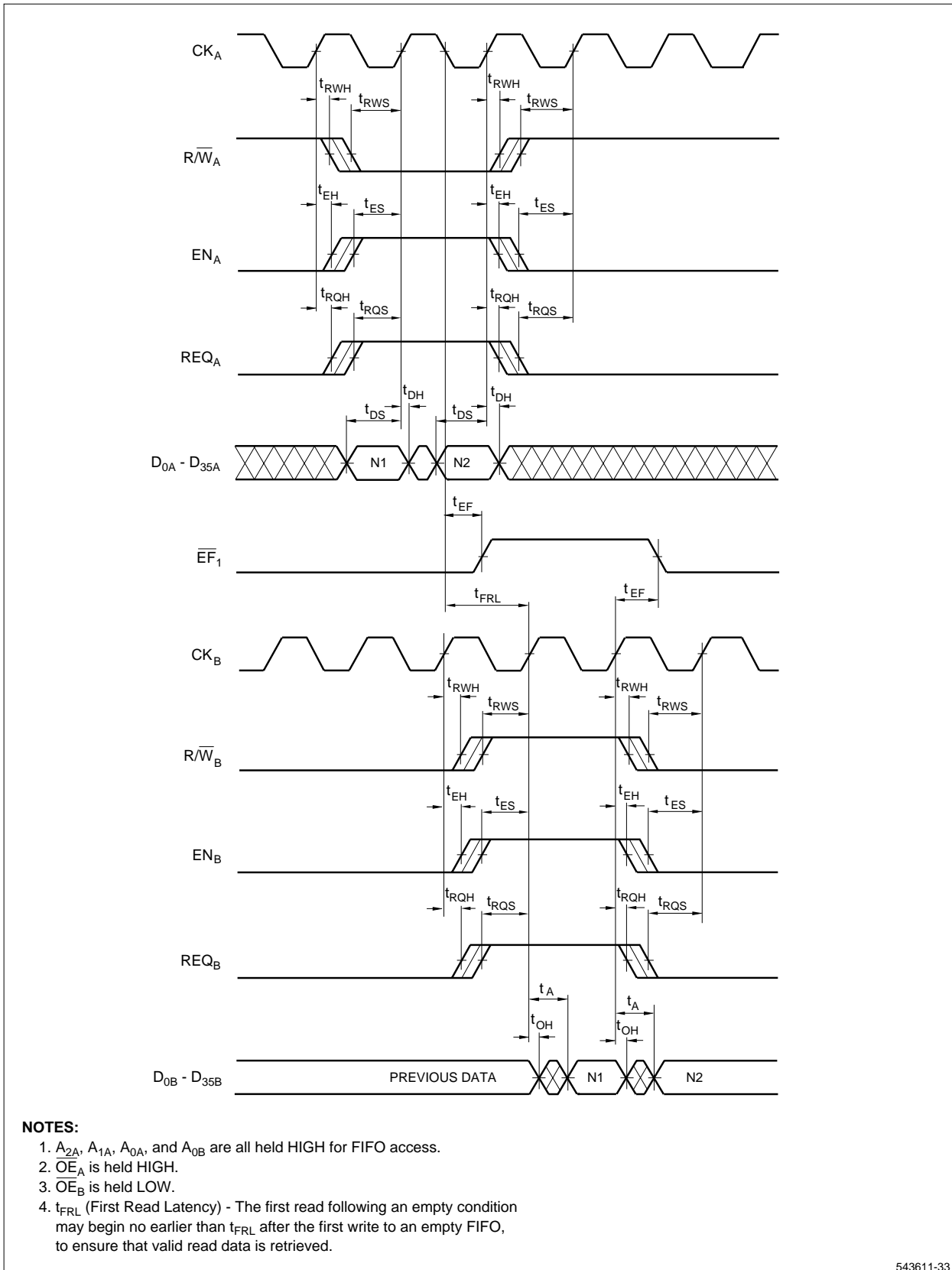

Figure 31. FIFO #1 Write and Read Operation in Near-Empty Region

TIMING DIAGRAMS (cont'd)

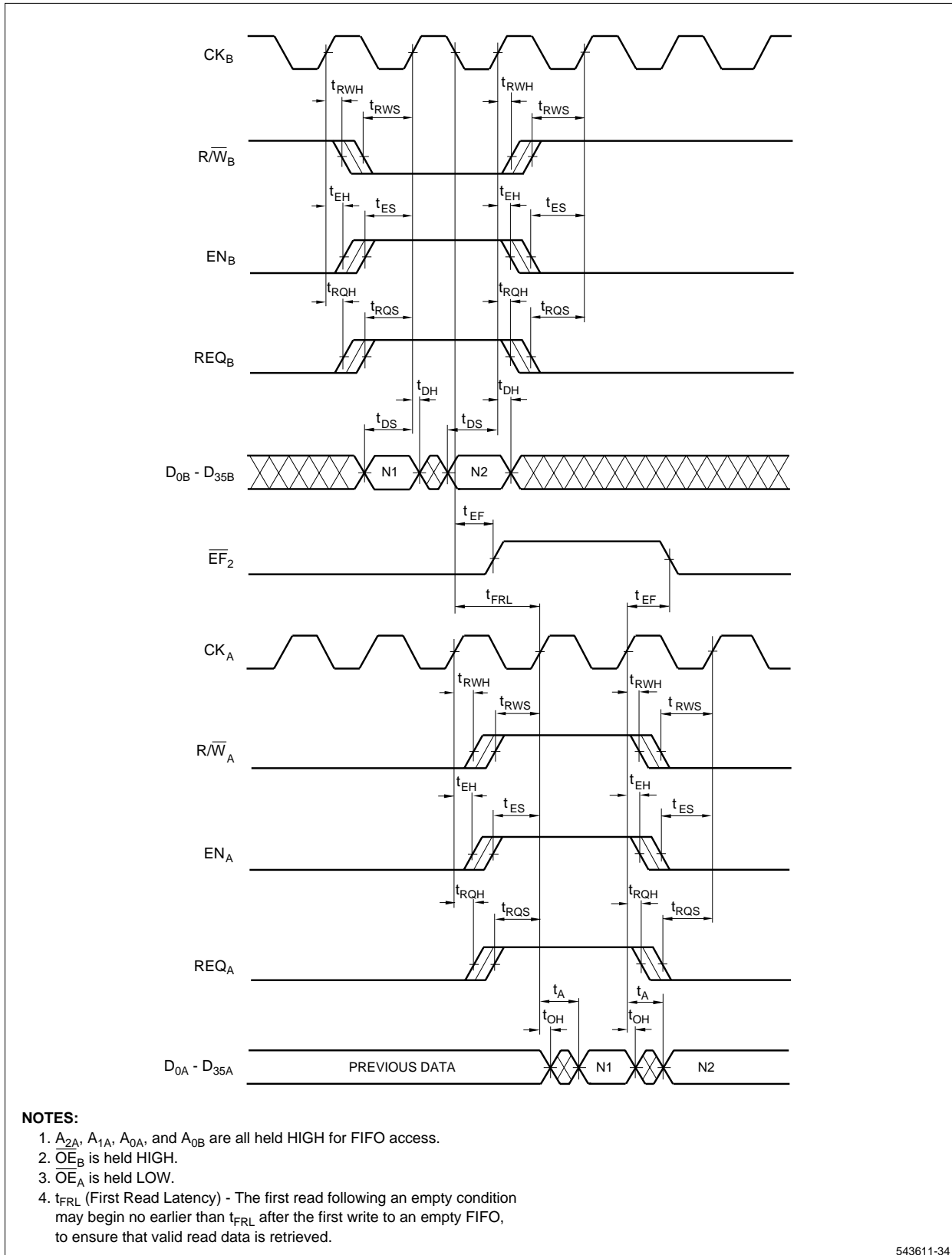

Figure 32. FIFO #2 Write and Read Operation in Near-Empty Region

TIMING DIAGRAMS (cont'd)

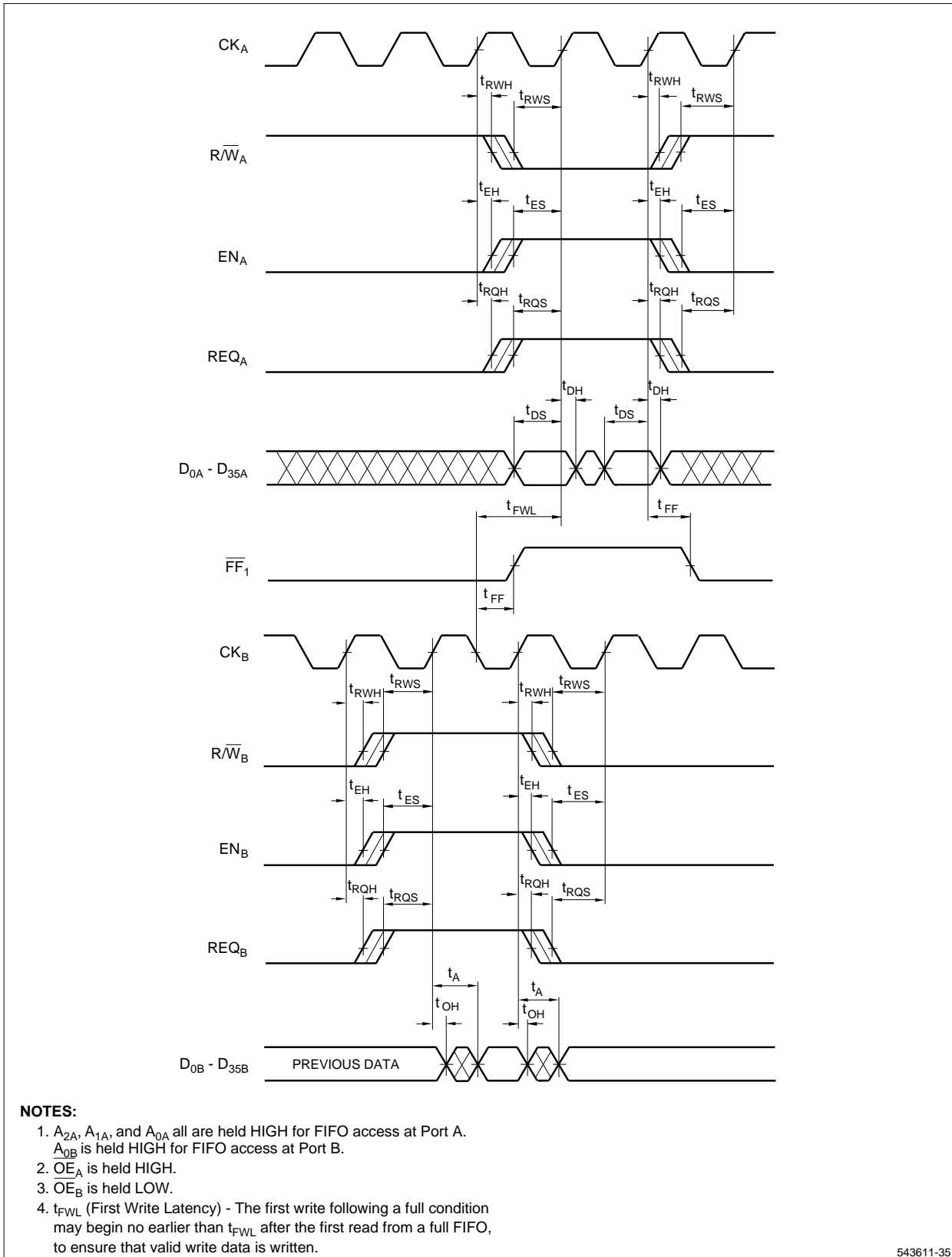
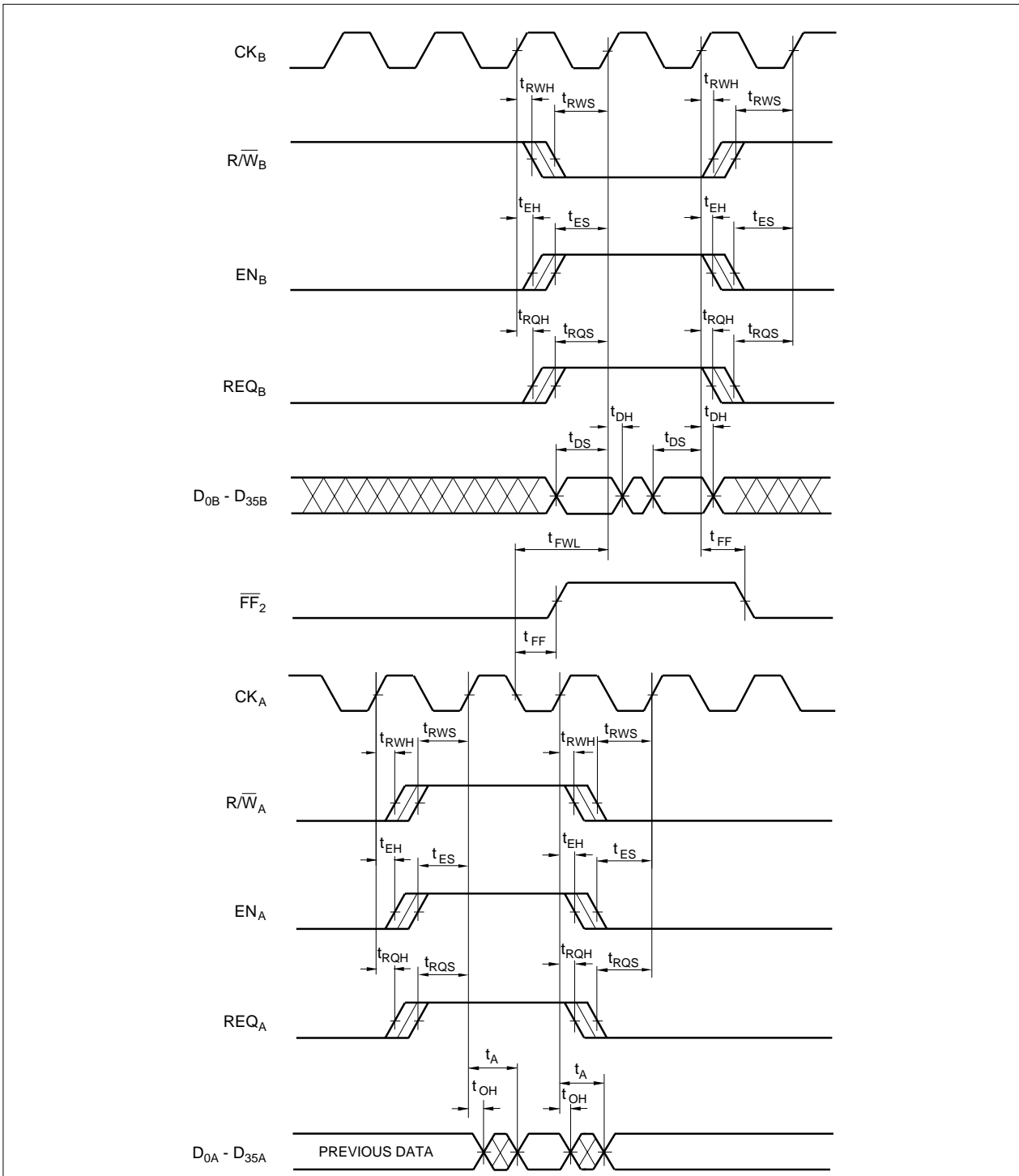

Figure 33. FIFO #1 Read and Write Operation in Near-Full Region

TIMING DIAGRAMS (cont'd)



NOTES:

1. A_{2A}, A_{1A}, and A_{0A} all are held HIGH for FIFO access at Port A.
A_{0B} is held HIGH for FIFO access at Port B.
2. OE_B is held HIGH.
3. OE_A is held LOW.
4. t_{FWL} (First Write Latency) - The first write following a full condition may begin no earlier than t_{FWL} after the first read from a full FIFO, to ensure that valid write data is written.

543611-36

Figure 34. FIFO #2 Read and Write Operation in Near-Full Region

TIMING DIAGRAMS (cont'd)

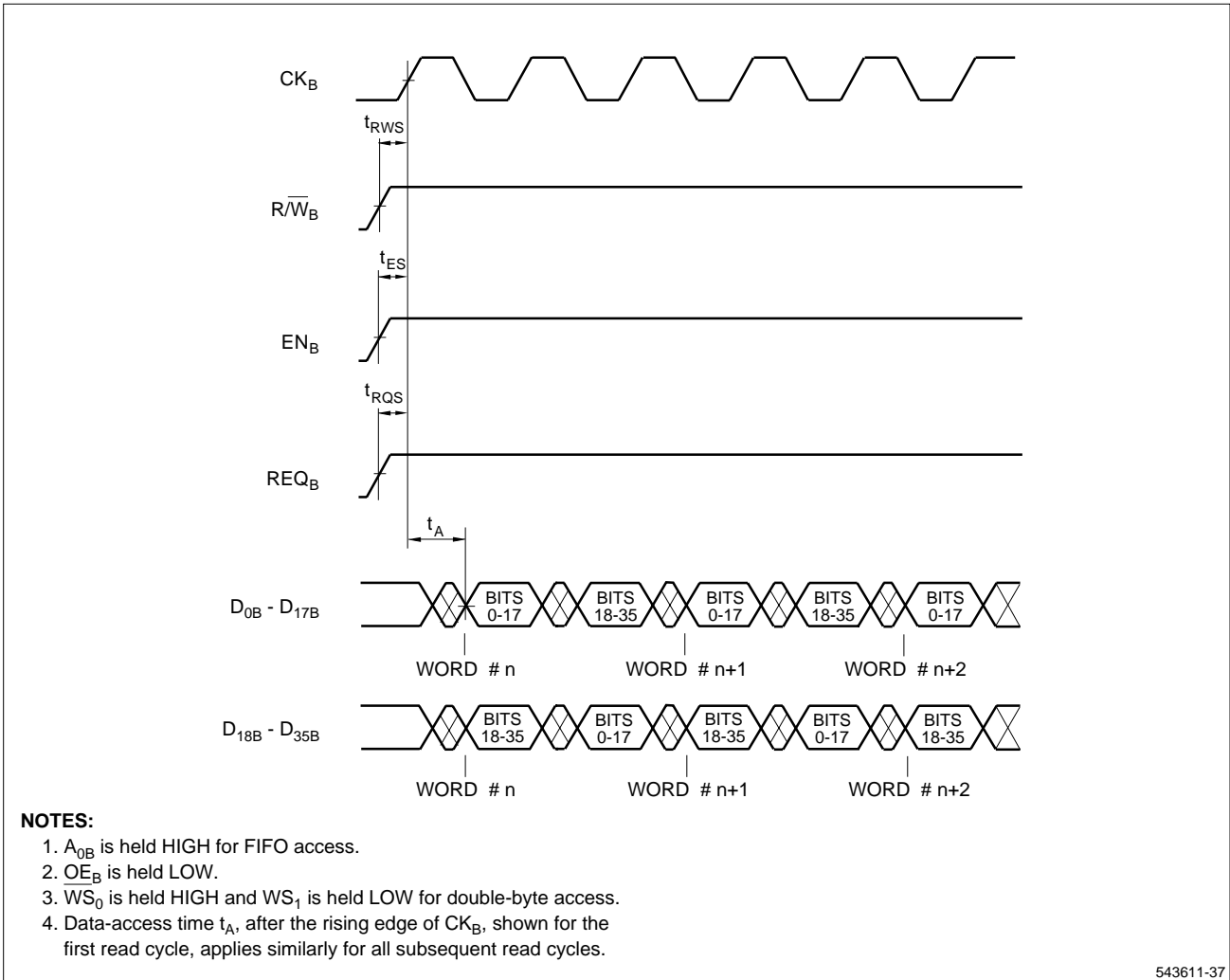
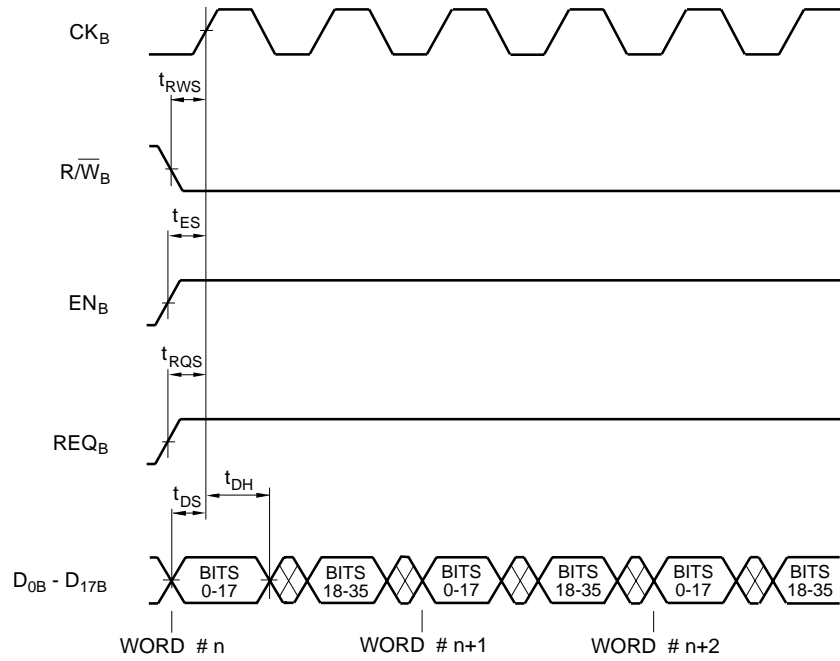

Figure 35. Port B Double-Byte FIFO #1 Read Access for 36-to-18 Funneling

543611-37

TIMING DIAGRAMS (cont'd)



NOTES:

1. \overline{A}_{0B} is held HIGH for FIFO access.
2. \overline{OE}_B is held HIGH.
3. WS_0 is held HIGH and WS_1 is held LOW for double-byte access.
4. Data-setup time t_{DS} and data-hold time t_{DH} , before and after the rising edge of CK_B , shown for the first write cycle, apply similarly for all subsequent write cycles.

543611-38

Figure 36. Port B Double-Byte FIFO #2 Write Access for 18-to-36 Defunneling

TIMING DIAGRAMS (cont'd)

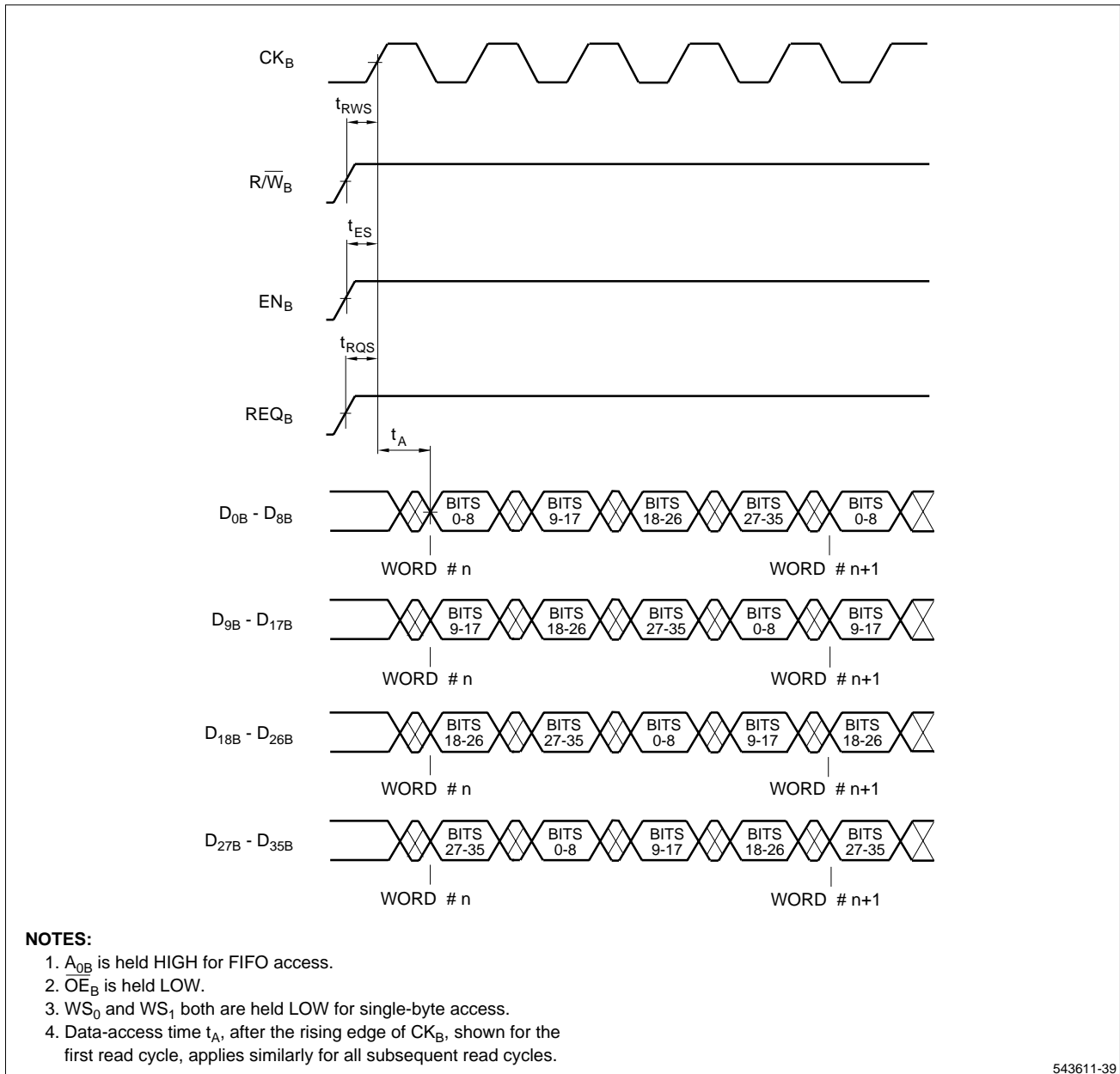

Figure 37. Port B Single-Byte FIFO #1 Read Access for 36-to-9 Funneling

TIMING DIAGRAMS (cont'd)

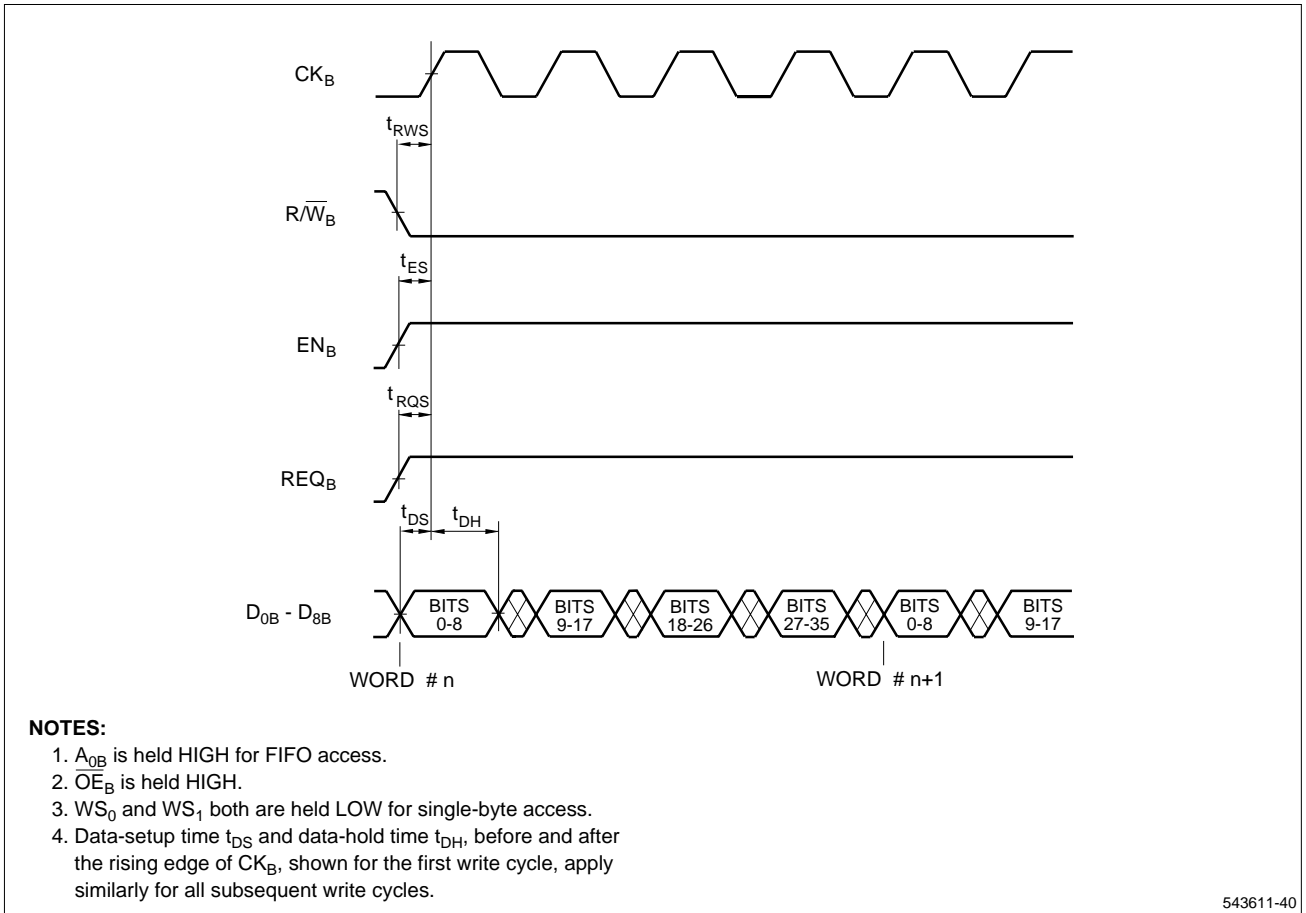

Figure 38. Port B Single-Byte FIFO #2 Write Access for

TIMING DIAGRAMS (cont'd)

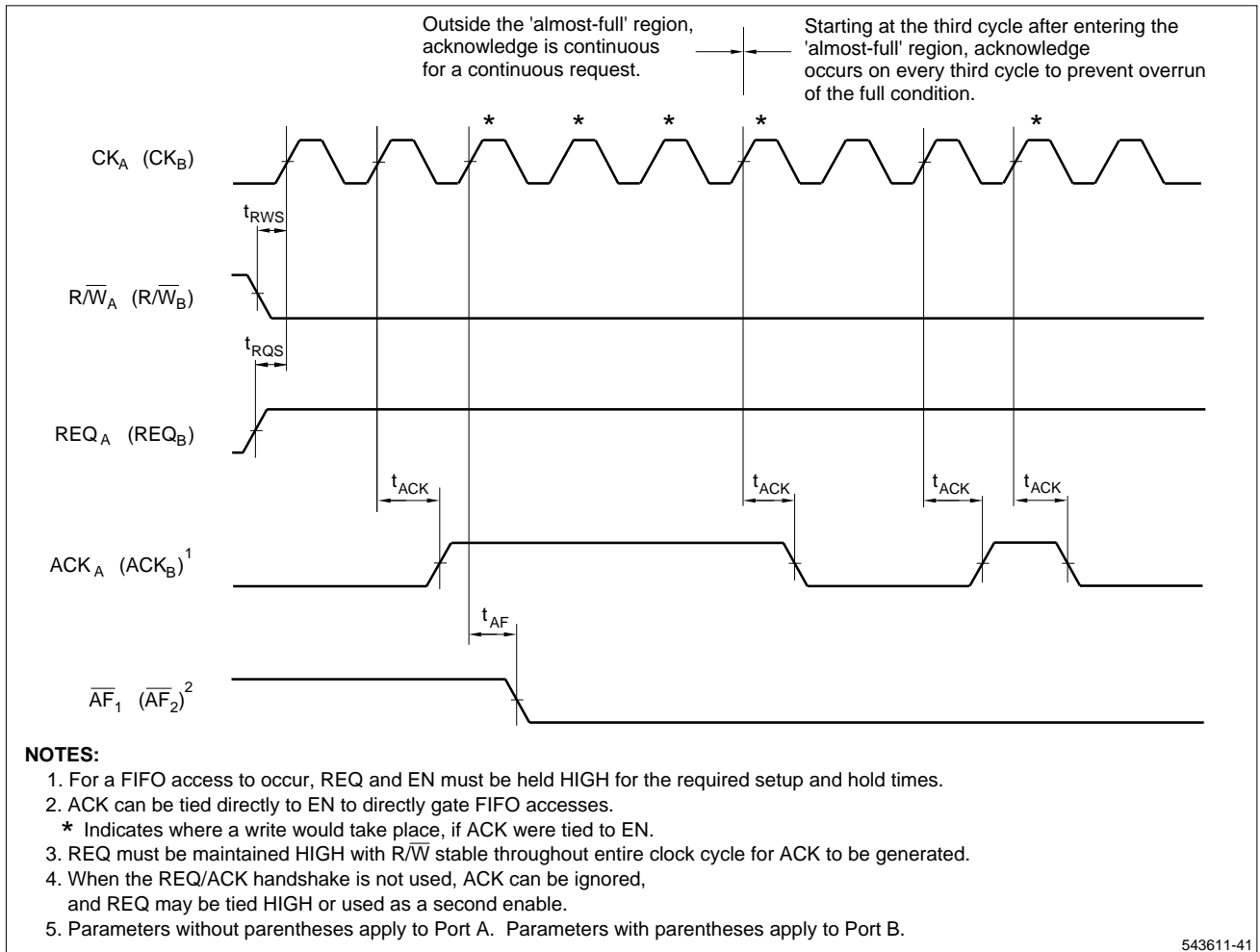
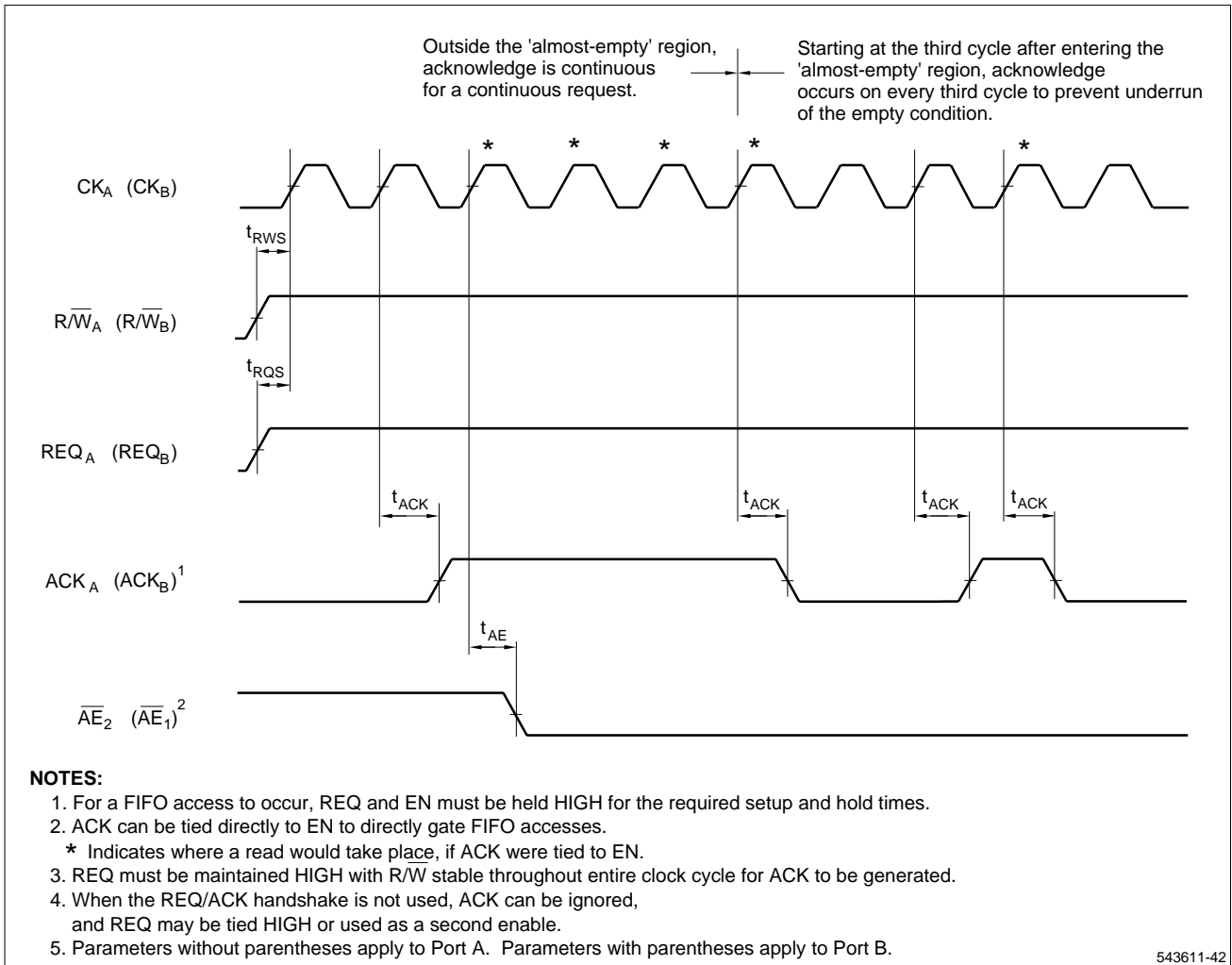

Figure 39. Write Request/Acknowledge Handshake

TIMING DIAGRAMS (cont'd)



543611-42

Figure 40. Read Request/Acknowledge Handshake

TIMING DIAGRAMS (cont'd)

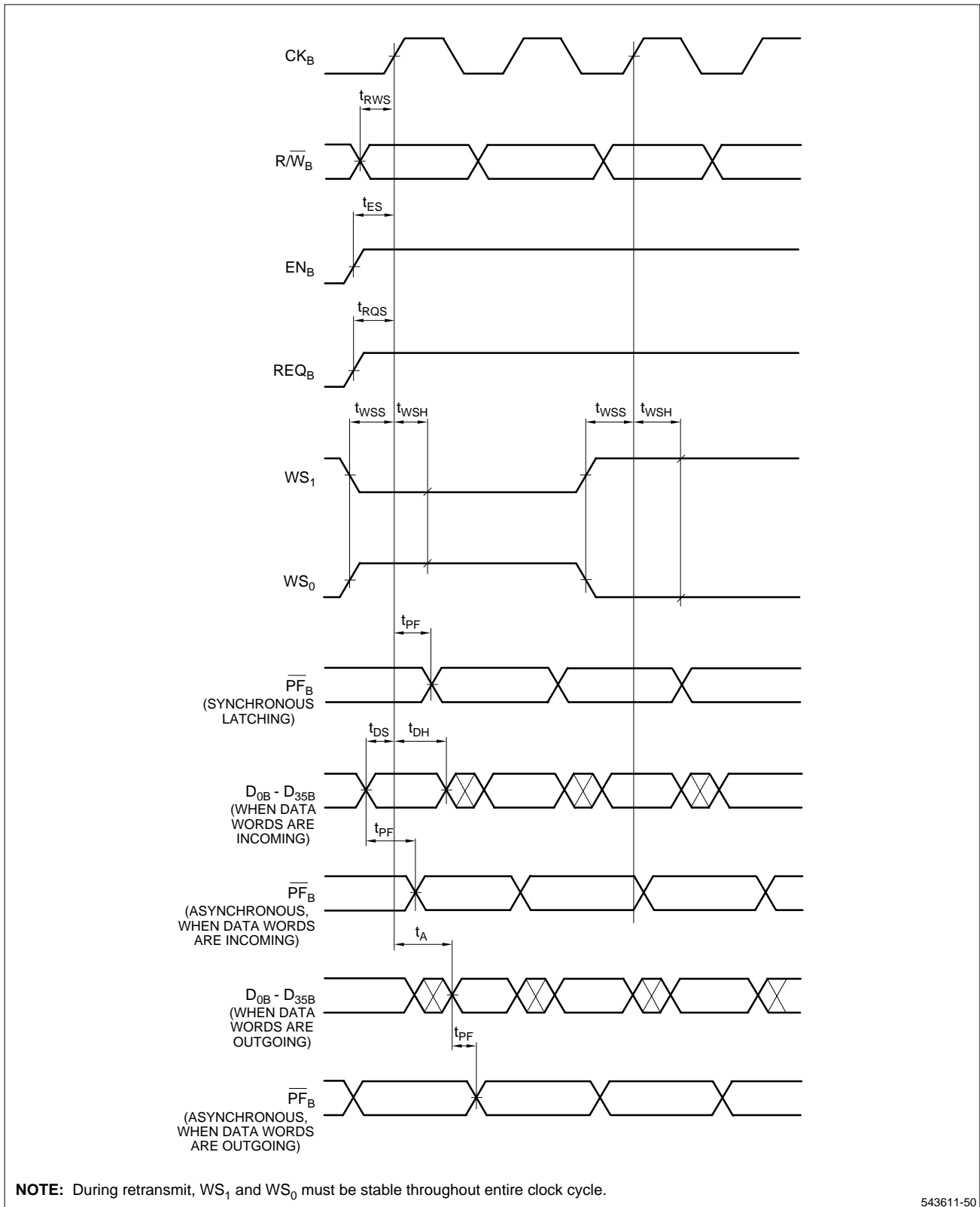

Figure 41. Changing Port B Word-Width Selection During Operation

TIMING DIAGRAMS (cont'd)

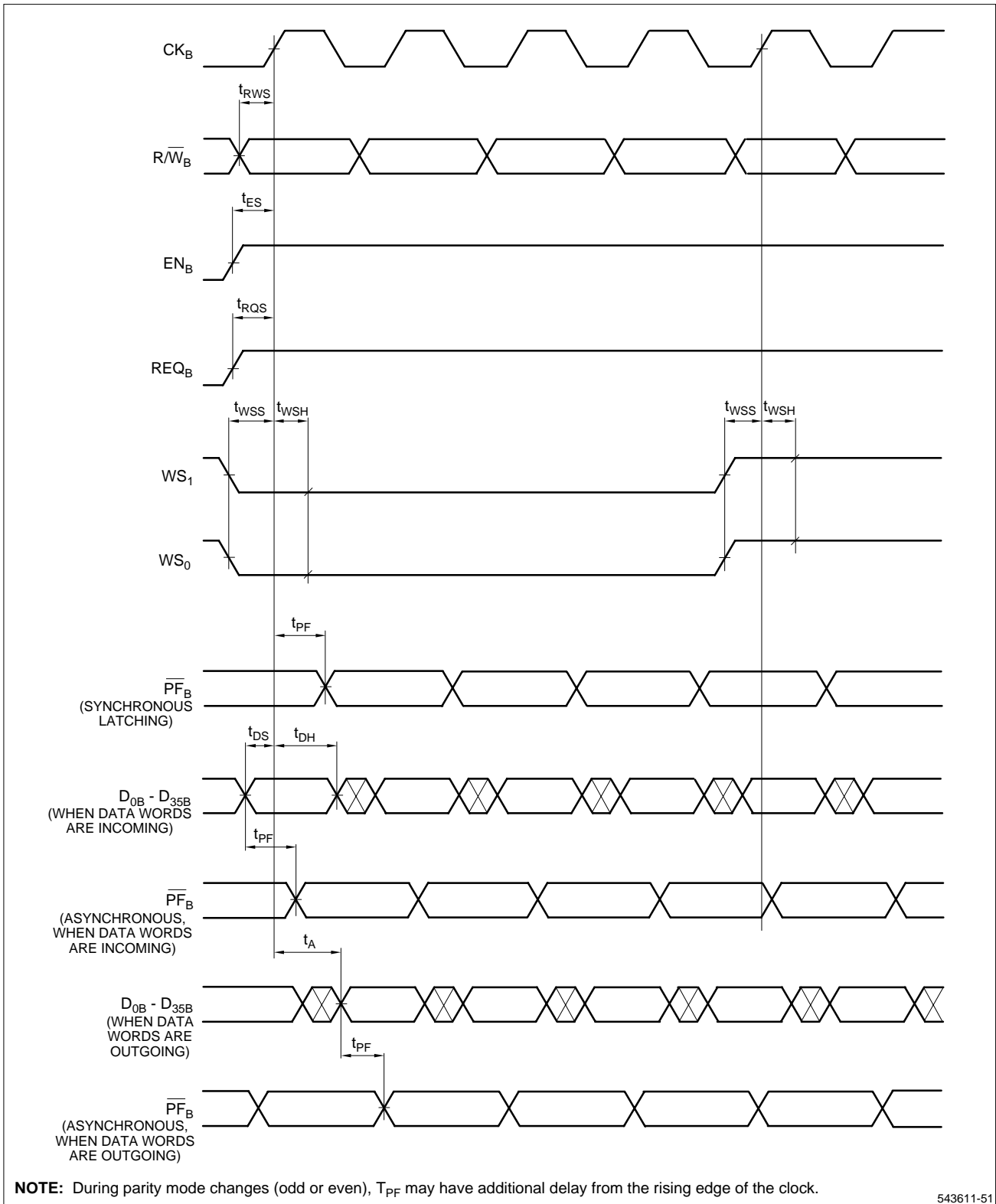
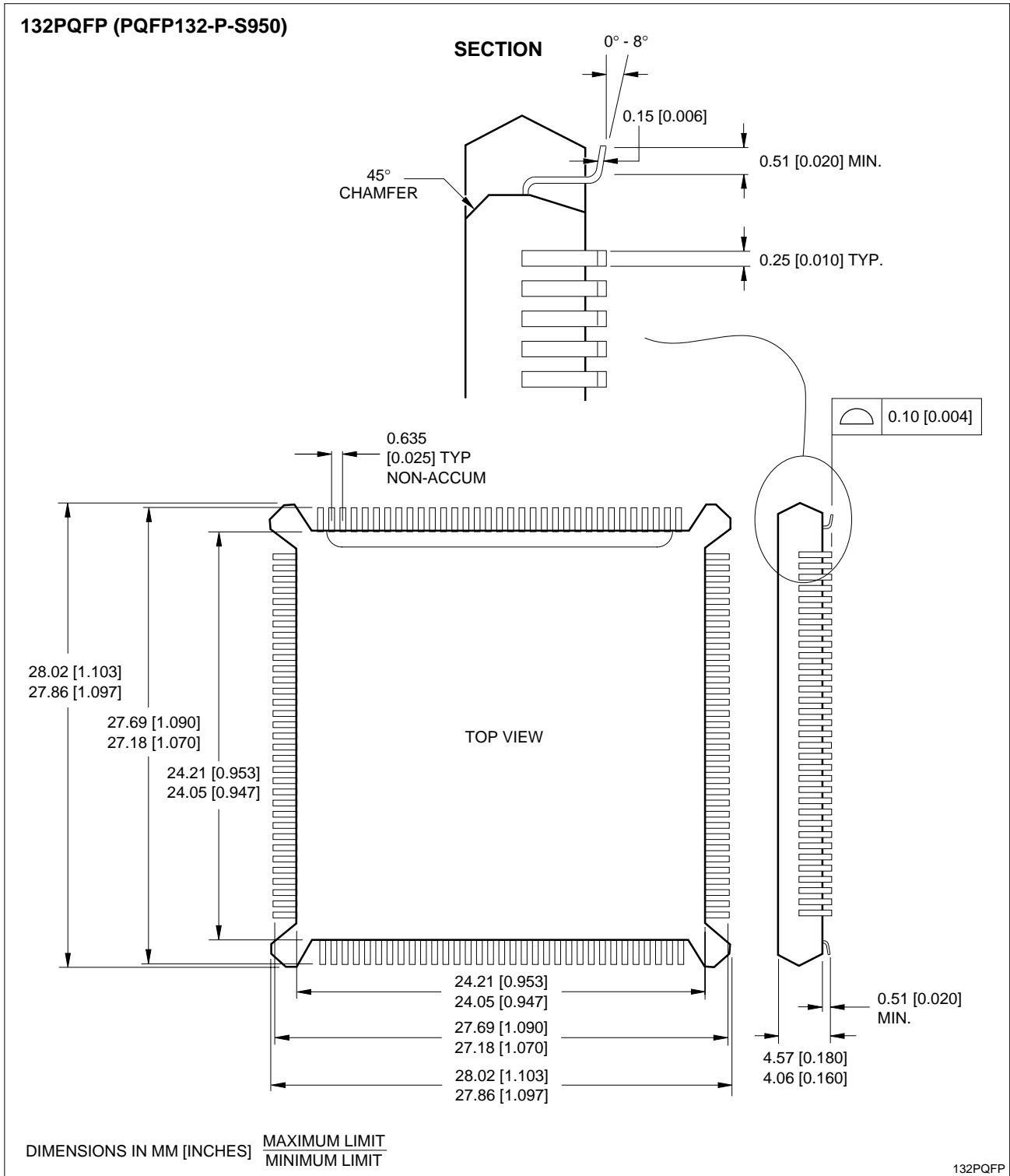
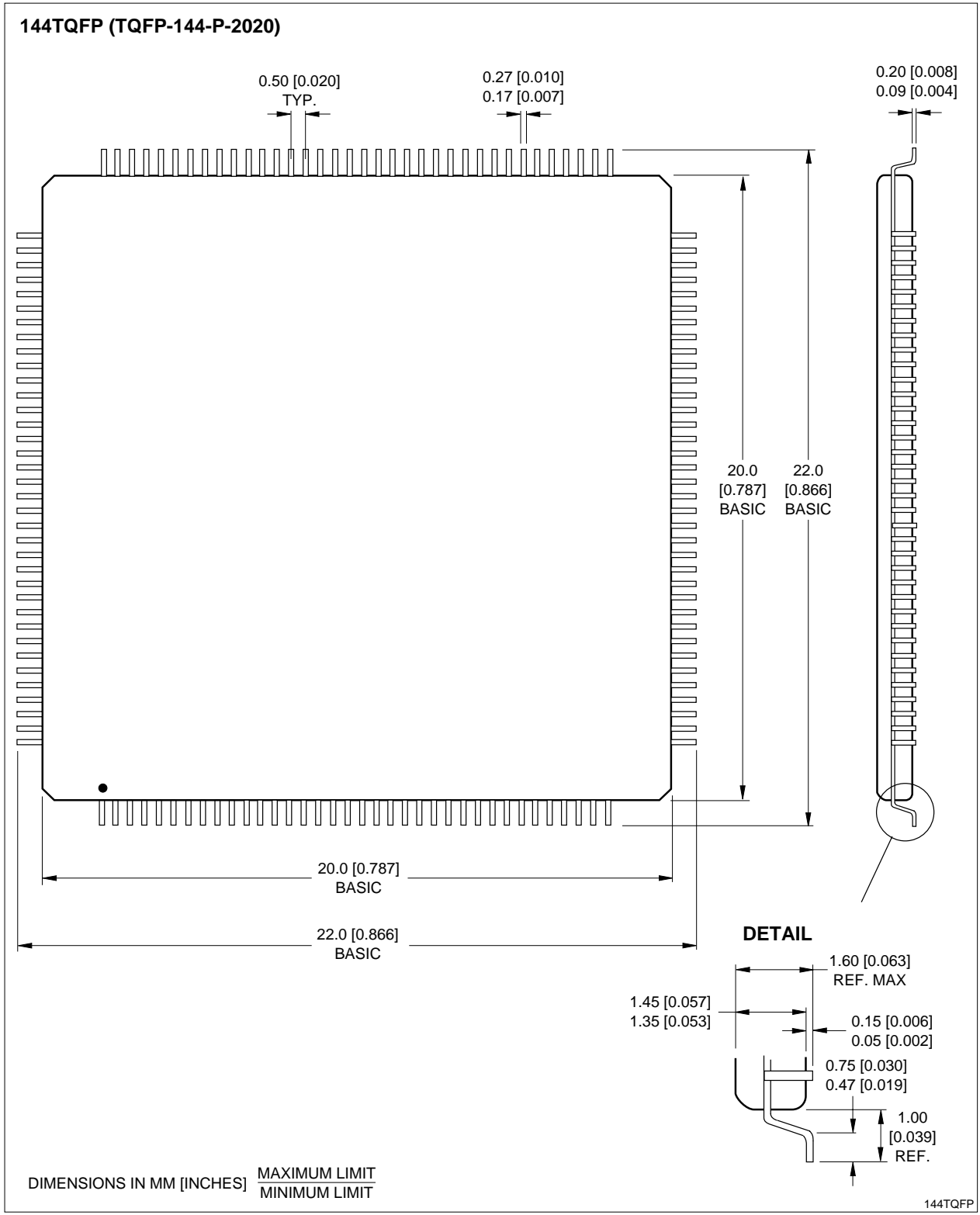

Figure 42. Parity Generation

PACKAGE DIAGRAMS



132-pin PQFP



144-pin TQFP

ORDERING INFORMATION

LH543611/21 Device Type	X Package	- ## Speed	
			{ 15 20 25 } Cycle Times (ns) { 30 35 }
			{ M 144-pin, Thin Quad Flat Package (TQFP144-P-2020) P 132-pin, Plastic Quad Flat Package (PQFP132-P-S950) }
512 x 36 x 2/1K x 36 x 2 Bidirectional FIFO			
Example: LH543611M-15 (512 x 36 x 2 Bidirectional FIFO, 15 ns, 144-pin, Thin Quad Flat Package)			

543611-43

NOTE:

For PQFP-to-PGA conversion for through-hole board designs, SHARP recommends QFP-to-PGA adaptors from ISI (Interconnect Systems Inc.) ISI makes three models that can map the LH543611/21 132-pin PQFP to a 13x13 PGA (100 mil); mode #A 13225-1® map to a SHARP specific 120-pin PGA. For more information, contact SHARP or ISI directly at P.O. Box 1089, Simi Valley, CA 93062, Tel: (805) 581-5626.