

LH28F800SG-L (FOR SOP)

8 M-bit (512 kB x 16) SmartVoltage Flash Memory

DESCRIPTION

The LH28F800SG-L flash memory with Smart Voltage technology is a high-density, low-cost, nonvolatile, read/write storage solution for a wide range of applications. The LH28F800SG-L can operate at $V_{CC} = 2.7\text{ V}$ and $V_{PP} = 2.7\text{ V}$. Its low voltage operation capability realizes longer battery life and suits for cellular phone application. Its symmetrically-blocked architecture, flexible voltage and enhanced cycling capability provide for highly flexible component suitable for resident flash arrays, SIMMs and memory cards. Its enhanced suspend capabilities provide for an ideal solution for code + data storage applications. For secure code storage applications, such as networking, where code is either directly executed out of flash or downloaded to DRAM, the LH28F800SG-L offers three levels of protection : absolute protection with V_{PP} at GND, selective hardware block locking, or flexible software block locking. These alternatives give designers ultimate control of their code security needs.

FEATURES

- SmartVoltage technology
 - 2.7 V, 3.3 V or 5 V V_{CC}
 - 2.7 V, 3.3 V, 5 V or 12 V V_{PP}
- High performance read access time
 - LH28F800SG-L70
 - 70 ns (5.0±0.25 V)/80 ns (5.0±0.5 V)/
85 ns (3.3±0.3 V)/100 ns (2.7 to 3.0 V)
 - LH28F800SG-L10
 - 100 ns (5.0 ±0.5 V)/100 ns (3.3±0.3 V)/
120 ns (2.7 to 3.0 V)
- Enhanced automated suspend options
 - Word write suspend to read
 - Block erase suspend to word write
 - Block erase suspend to read
- Enhanced data protection features
 - Absolute protection with $V_{PP} = \text{GND}$
 - Flexible block locking
 - Block erase/word write lockout during power transitions
- SRAM-compatible write interface
- High-density symmetrically-blocked architecture
 - Sixteen 32 k-word erasable blocks
- Enhanced cycling capability
 - 100 000 block erase cycles
 - 1.6 million block erase cycles/chip
- Low power management
 - Deep power-down mode
 - Automatic power saving mode decreases I_{CC} in static mode
- Automated word write and block erase
 - Command user interface
 - Status register
- ETOX™* V nonvolatile flash technology
- Package
 - 44-pin SOP (SOP044-P-0600)

* ETOX is a trademark of Intel Corporation.

COMPARISON TABLE

VERSIONS	OPERATING TEMPERATURE	PACKAGE	WRITE PROTECT FUNCTION
LH28F800SG-L (FOR SOP)	0 to +70°C	44-pin SOP	Controlled by RP# pin
LH28F800SG-L*1 (FOR TSOP, CSP)	0 to +70°C	48-pin TSOP (I) 48-ball CSP	Controlled by WP# and RP# pins
LH28F800SGH-L*1 (FOR TSOP, CSP)	-40 to +85°C	48-pin TSOP (I) 48-ball CSP	Controlled by WP# and RP# pins

*1 Refer to the datasheet of LH28F800SG-L/SGH-L (FOR TSOP, CSP).

PIN CONNECTIONS

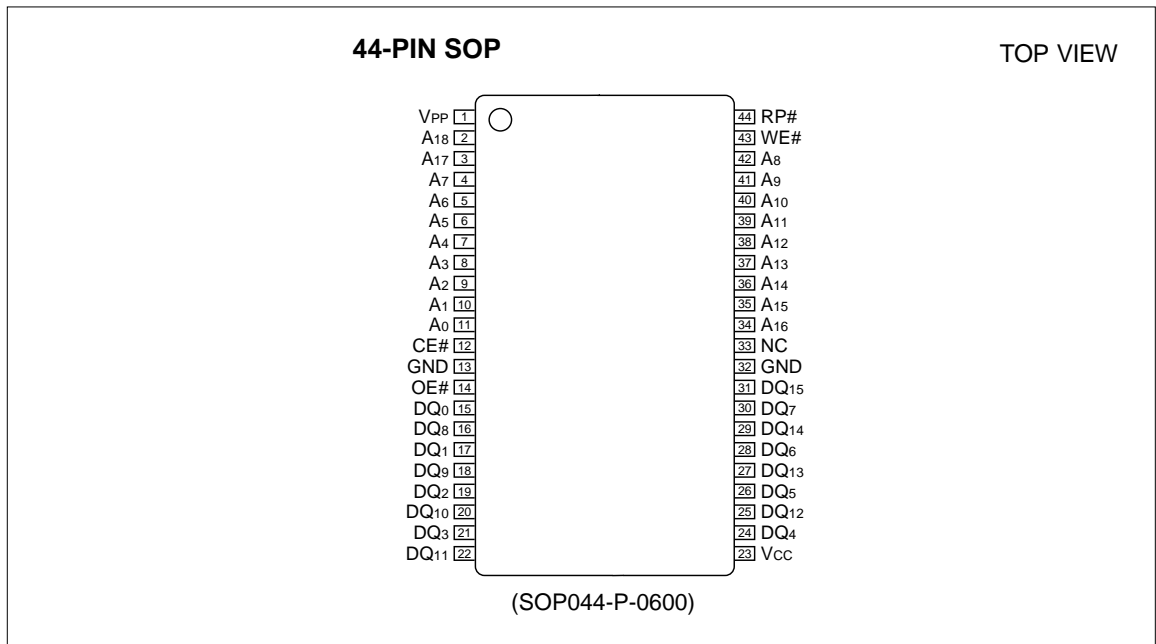

BLOCK DIAGRAMS

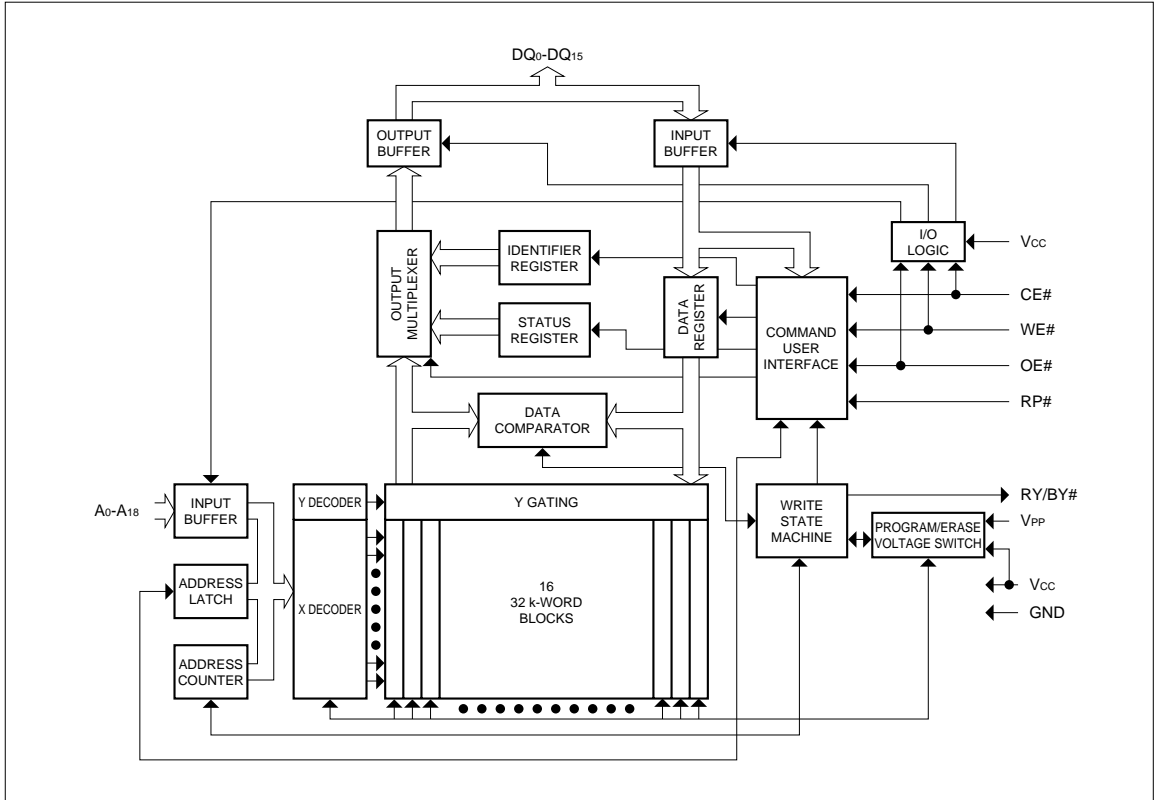

PIN DESCRIPTION

SYMBOL	TYPE	NAME AND FUNCTION
A ₀ -A ₁₈	INPUT	ADDRESS INPUTS : Inputs for addresses during read and write operations. Addresses are internally latched during a write cycle.
DQ ₀ -DQ ₁₅	INPUT/ OUTPUT	DATA INPUT/OUTPUTS : Inputs data and commands during CUI write cycles; outputs data during memory array, status register, and identifier code read cycles. Data pins float to high-impedance when the chip is deselected or outputs are disabled. Data is internally latched during a write cycle.
CE#	INPUT	CHIP ENABLE : Activates the device's control logic, input buffers, decoders, and sense amplifiers. CE#-high deselects the device and reduces power consumption to standby levels.
RP#	INPUT	RESET/DEEP POWER-DOWN : Puts the device in deep power-down mode and resets internal automation. RP#-high enables normal operation. When driven low, RP# inhibits write operations which provide data protection during power transitions. Exit from deep power-down sets the device to read array mode. RP# at V _{HH} allows to set permanent lock-bit. Block erase, word write, or lock-bit configuration with V _{IH} < RP# < V _{HH} produce spurious results and should not be attempted.
OE#	INPUT	OUTPUT ENABLE : Controls the device's outputs during a read cycle.
WE#	INPUT	WRITE ENABLE : Controls writes to the CUI and array blocks. Addresses and data are latched on the rising edge of the WE# pulse.
RY/BY#	OUTPUT	READY/BUSY : Indicates the status of the internal WSM. When low, the WSM is performing an internal operation (block erase, word write, or lock-bit configuration). RY/BY#-high indicates that the WSM is ready for new commands, block erase is suspended, and word write is inactive, word write is suspended, or the device is in deep power-down mode. RY/BY# is always active and does not float when the chip is deselected or data outputs are disabled.
V _{PP}	SUPPLY	BLOCK ERASE, WORD WRITE, LOCK-BIT CONFIGURATION POWER SUPPLY : For erasing array blocks, writing word, or configuring lock-bits. With V _{PP} ≤ V _{PPLK} , memory contents cannot be altered. Block erase, word write, and lock-bit configuration with an invalid V _{PP} (see Section 6.2.3 "DC CHARACTERISTICS") produce spurious results and should not be attempted.
V _{CC}	SUPPLY	DEVICE POWER SUPPLY : Internal detection configures the device for 2.7 V, 3.3 V or 5 V operation. To switch from one voltage to another, ramp V _{CC} down to GND and then ramp V _{CC} to the new voltage. Do not float any power pins. With V _{CC} ≤ V _{LKO} , all write attempts to the flash memory are inhibited. Device operations at invalid V _{CC} voltage (see Section 6.2.3 "DC CHARACTERISTICS") produce spurious results and should not be attempted.
GND	SUPPLY	GROUND : Do not float any ground pins.
NC		NO CONNECT : Lead is not internal connected; recommend to be floated.

1 INTRODUCTION

This datasheet contains LH28F800SG-L specifications. Section 1 provides a flash memory overview. Sections 2, 3, 4, and 5 describe the memory organization and functionality. Section 6 covers electrical specifications. LH28F800SG-L flash memory documentation also includes ordering information which is referenced in Section 7.

1.1 New Features

Key enhancements of LH28F800SG-L SmartVoltage flash memory are :

- SmartVoltage Technology
- Enhanced Suspend Capabilities
- In-System Block Locking
- Permanent Lock Capability

Note following important differences :

- VPPLK has been lowered to 1.5 V to support 3.3 V and 5 V block erase, word write, and lock-bit configuration operations. Designs that switch VPP off during read operations should make sure that the VPP voltage transitions to GND.
- To take advantage of SmartVoltage technology, allow VCC connection to 2.7 V, 3.3 V or 5 V.
- Once set the permanent lock bit, the blocks which have been set block lock-bit can not be erased, written forever.

1.2 Product Overview

The LH28F800SG-L is a high-performance 8 M-bit SmartVoltage flash memory organized as 512 k-word of 16 bits. The 512 k-word of data is arranged in sixteen 32 k-word blocks which are individually erasable, lockable, and unlockable in-system. The memory map is shown in **Fig. 1**.

SmartVoltage technology provides a choice of VCC and VPP combinations, as shown in **Table 1**, to meet system performance and power expectations. 2.7 to 3.6 V VCC consumes approximately one-fifth

the power of 5 V VCC. But, 5 V VCC provides the highest read performance. VPP at 2.7 V, 3.3 V and 5 V eliminates the need for a separate 12 V converter, while VPP = 12 V maximizes block erase and word write performance. In addition to flexible erase and program voltages, the dedicated VPP pin gives complete data protection when $V_{PP} \leq V_{PPLK}$.

Table 1 VCC and VPP Voltage Combinations Offered by SmartVoltage Technology

VCC VOLTAGE	VPP VOLTAGE
2.7 V	2.7 V, 3.3 V, 5 V, 12 V
3.3 V	3.3 V, 5 V, 12 V
5 V	5 V, 12 V

Internal VCC and VPP detection circuitry automatically configures the device for optimized read and write operations.

A command User Interface (CUI) serves as the interface between the system processor and internal operation of the device. A valid command sequence written to the CUI initiates device automation. An internal Write State Machine (WSM) automatically executes the algorithms and timing necessary for block erase, word write, and lock-bit configuration operations.

A block erase operation erases one of the device's 32 k-word blocks typically within 1.2 second (5 V VCC, 12 V VPP) independent of other blocks. Each block can be independently erased 100 000 times (1.6 million block erases per device). Block erase suspend mode allows system software to suspend block erase to read data from, or write data to any other block.

Writing memory data is performed in word increments typically within 7.5 μ s (5 V VCC, 12 V VPP). Word write suspend mode enables the system to read data from, or write data to any other flash memory array location.

The selected block can be locked or unlocked individually by the combination of sixteen block lock bits and the RP#. Block erase or word write must not be carried out by setting block lock bits and RP# to V_{IH}. Even if RP# is set to V_{HH}, block erase and word write to locked blocks is prohibited by setting permanent lock bit.

The status register or RY/BY# indicates when the WSM's block erase, word write, or lock-bit configuration operation is finished.

The RY/BY# output gives an additional indicator of WSM activity by providing both a hardware signal of status (versus software polling) and status masking (interrupt masking for background block erase, for example). Status polling using RY/BY# minimizes both CPU overhead and system power consumption. When low, RY/BY# indicates that the WSM is performing a block erase, word write, or lock-bit configuration.

RY/BY#-high indicates that the WSM is ready for a new command, block erase is suspended (and word write is inactive), word write is suspended, or the device is in deep power-down mode.

The access time is 70 ns (t_{AVQV}) at the V_{CC} supply voltage range of 4.75 to 5.25 V over the temperature range (0 to +70°C). At 4.5 to 5.5 V V_{CC}, the access time is 80 ns or 100 ns. At lower V_{CC} voltage, the access time is 85 ns or 100 ns (3.0 to 3.6 V) and 100 ns or 120 ns (2.7 to 3.0 V).

The Automatic Power Saving (APS) feature substantially reduces active current when the device is in static mode (addresses not switching). In APS mode, the typical I_{CCR} current is 1 mA at 5 V V_{CC} and 3 mA at 2.7 to 3.6 V V_{CC}.

When CE# and RP# pins are at V_{CC}, the I_{CC} CMOS standby mode is enabled. When the RP# pin is at GND, deep power-down mode is enabled which minimizes power consumption and provides write protection during reset. A reset time (t_{PHQV}) is required from RP# switching high until outputs are valid. Likewise, the device has a wake time (t_{PHL}) from RP#-high until writes to the CUI are recognized. With RP# at GND, the WSM is reset and the status register is cleared.

7FFFF	32 k-Word Block	15
78000		
77FFF	32 k-Word Block	14
70000		
6FFFF	32 k-Word Block	13
68000		
67FFF	32 k-Word Block	12
60000		
5FFFF	32 k-Word Block	11
58000		
57FFF	32 k-Word Block	10
50000		
4FFFF	32 k-Word Block	9
48000		
47FFF	32 k-Word Block	8
40000		
3FFFF	32 k-Word Block	7
38000		
37FFF	32 k-Word Block	6
30000		
2FFFF	32 k-Word Block	5
28000		
27FFF	32 k-Word Block	4
20000		
1FFFF	32 k-Word Block	3
18000		
17FFF	32 k-Word Block	2
10000		
0FFFF	32 k-Word Block	1
08000		
07FFF	32 k-Word Block	0
00000		

Fig. 1 Memory Map

2 PRINCIPLES OF OPERATION

The LH28F800SG-L SmartVoltage flash memory includes an on-chip WSM to manage block erase, word write, and lock-bit configuration functions. It allows for : 100% TTL-level control inputs, fixed power supplies during block erasure, word write, and lock-bit configuration, and minimal processor overhead with RAM-like interface timings.

After initial device power-up or return from deep power-down mode (see **Table 2 "Bus Operations"**), the device defaults to read array mode. Manipulation of external memory control pins allow array read, standby, and output disable operations.

Status register and identifier codes can be accessed through the CUI independent of the VPP voltage. High voltage on VPP enables successful block erasure, word writing, and lock-bit configuration. All functions associated with altering memory contents — block erase, word write, lock-bit configuration, status, and identifier codes — are accessed via the CUI and verified through the status register.

Commands are written using standard micro-processor write timings. The CUI contents serve as input to the WSM, which controls the block erase, word write, and lock-bit configuration. The internal algorithms are regulated by the WSM, including pulse repetition, internal verification, and margining of data. Addresses and data are internally latched during write cycles. Writing the appropriate command outputs array data, accesses the identifier codes, or outputs status register data.

Interface software that initiates and polls progress of block erase, word write, and lock-bit configuration can be stored in any block. This code is copied to and executed from system RAM during flash memory updates. After successful completion, reads are again possible via the Read Array command. Block erase suspend allows system

software to suspend a block erase to read/write data from/to blocks other than that which is suspended. Word write suspend allows system software to suspend a word write to read data from any other flash memory array location.

2.1 Data Protection

Depending on the application, the system designer may choose to make the VPP power supply switchable (available only when memory block erases, word writes, or lock-bit configurations are required) or hardwired to VPPH1/2/3. The device accommodates either design practice and encourages optimization of the processor-memory interface.

When $V_{PP} \leq V_{PPLK}$, memory contents cannot be altered. The CUI, with two-step block erase, word write, or lock-bit configuration command sequences, provides protection from unwanted operations even when high voltage is applied to VPP. All write functions are disabled when VCC is below the write lockout voltage VLKO or when RP# is at VIL. The device's block locking capability provides additional protection from inadvertent code or data alteration by gating erase and word write operations.

3 BUS OPERATION

The local CPU reads and writes flash memory in-system. All bus cycles to or from the flash memory conform to standard microprocessor bus cycles.

3.1 Read

Information can be read from any block, identifier codes, or status register independent of the VPP voltage. RP# can be at either VIH or VHH.

The first task is to write the appropriate read mode command (Read Array, Read Identifier Codes, or Read Status Register) to the CUI. Upon initial device power-up or after exit from deep power-down mode, the device automatically resets to read

array mode. Four control pins dictate the data flow in and out of the component : CE#, OE#, WE# and RP#. CE# and OE# must be driven active to obtain data at the outputs. CE# is the device selection control, and when active enables the selected memory device. OE# is the data output (DQ0-DQ15) control and when active drives the selected memory data onto the I/O bus. WE# must be at V_{IH} and RP# must be at V_{IH} or V_{HH} . **Fig. 13** illustrates read cycle.

3.2 Output Disable

With OE# at a logic-high level (V_{IH}), the device outputs are disabled. Output pins DQ0-DQ15 are placed in a high-impedance state.

3.3 Standby

CE# at a logic-high level (V_{IH}) places the device in standby mode which substantially reduces device power consumption. DQ0-DQ15 outputs are placed in a high-impedance state independent of OE#. If deselected during block erase, word write, or lock-bit configuration, the device continues functioning, and consuming active power until the operation completes.

3.4 Deep Power-Down

RP# at V_{IL} initiates the deep power-down mode.

In read modes, RP#-low deselects the memory, places output drivers in a high-impedance state and turns off all internal circuits. RP# must be held low for a minimum of 100 ns. Time t_{PHQV} is required after return from power-down until initial memory access outputs are valid. After this wake-up interval, normal operation is restored. The CUI is reset to read array mode and status register is set to 80H.

During block erase, word write, or lock-bit configuration modes, RP#-low will abort the operation. RY/BY# remains low until the reset operation is complete. Memory contents being altered are no longer valid; the data may be partially erased or written. Time t_{PHWL} is required after RP# goes to logic-high (V_{IH}) before another command can be written.

As with any automated device, it is important to assert RP# during system reset. When the system comes out of reset, it expects to read from the flash memory. Automated flash memories provide status information when accessed during block erase, word write, or lock-bit configuration modes. If a CPU reset occurs with no flash memory reset, proper CPU initialization may not occur because the flash memory may be providing status information instead of array data. SHARP's flash memories allow proper CPU initialization following a system reset through the use of the RP# input. In this application, RP# is controlled by the same RESET# signal that resets the system CPU.

3.5 Read Identifier Codes

The read identifier codes operation outputs the manufacture code, device code, block lock configuration codes for each block, and the permanent lock configuration code (see **Fig. 2**). Using the manufacture and device codes, the system CPU can automatically match the device with its proper algorithms. The block lock and permanent lock configuration codes identify locked and unlocked blocks and permanent lock-bit setting.

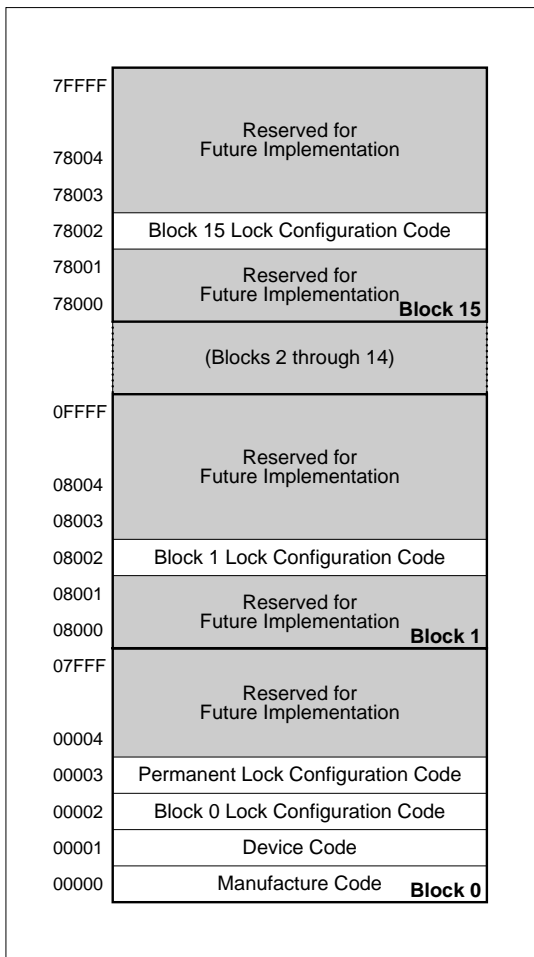

Fig. 2 Device Identifier Code Memory Map

3.6 Write

Writing commands to the CUI enable reading of device data and identifier codes. They also control inspection and clearing of the status register.

The Block Erase command requires appropriate command data and an address within the block to be erased. The Word Write command requires the command and address of the location to be written. Set Permanent and Block Lock-Bit commands require the command and address within the device (Permanent Lock) or block within the device (Block Lock) to be locked. The Clear Block Lock-Bits command requires the command and address within the device.

The CUI does not occupy an addressable memory location. It is written when WE# and CE# are active. The address and data needed to execute a command are latched on the rising edge of WE# or CE# (whichever goes high first). Standard microprocessor write timings are used. **Fig. 14** and **Fig. 15** illustrate WE# and CE# controlled write operations.

4 COMMAND DEFINITIONS

When the $V_{PP} \leq V_{PPLK}$, read operations from the status register, identifier codes, or blocks are enabled. Placing VPPH1/2/3 on VPP enables successful block erase, word write and lock-bit configuration operations.

Device operations are selected by writing specific commands into the CUI. **Table 3** defines these commands.

Table 2 Bus Operations

MODE	NOTE	RP#	CE#	OE#	WE#	ADDRESS	VPP	DQ0-15	RY/BY#
Read	1, 2, 3, 8	V _{IH} or V _{HH}	V _{IL}	V _{IL}	V _{IH}	X	X	D _{OUT}	X
Output Disable	3	V _{IH} or V _{HH}	V _{IL}	V _{IH}	V _{IH}	X	X	High Z	X
Standby	3	V _{IH} or V _{HH}	V _{IH}	X	X	X	X	High Z	X
Deep Power-Down	4	V _{IL}	X	X	X	X	X	High Z	V _{OH}
Read Identifier Codes	8	V _{IH} or V _{HH}	V _{IL}	V _{IL}	V _{IH}	See Fig. 2	X	(NOTE 5)	V _{OH}
Write	3, 6, 7, 8	V _{IH} or V _{HH}	V _{IL}	V _{IH}	V _{IL}	X	X	D _{IN}	X

NOTES :

1. Refer to **Section 6.2.3 "DC CHARACTERISTICS"**. When $V_{PP} \leq V_{PPLK}$, memory contents can be read, but not altered.
2. X can be V_{IL} or V_{IH} for control pins and addresses, and V_{PPLK} or V_{PPH1/2/3} for V_{PP}. See **Section 6.2.3 "DC CHARACTERISTICS"** for V_{PPLK} and V_{PPH1/2/3} voltages.
3. RY/BY# is V_{OL} when the WSM is executing internal block erase, word write, or lock-bit configuration algorithms. It is V_{OH} during when the WSM is not busy, in block erase suspend mode (with word write inactive), word write suspend mode, or deep power-down mode.
4. RP# at GND±0.2 V ensures the lowest deep power-down current.
5. See **Section 4.2** for read identifier code data.
6. V_{IH} < RP# < V_{HH} produce spurious results and should not be attempted.
7. Refer to **Table 3** for valid D_{IN} during a write operation.
8. Don't use the timing both OE# and WE# are V_{IL}.

Table 3 Command Definitions (NOTE 9)

COMMAND	BUS CYCLES REQ'D.	NOTE	FIRST BUS CYCLE			SECOND BUS CYCLE		
			Oper (NOTE 1)	Addr (NOTE 2)	Data (NOTE 3)	Oper (NOTE 1)	Addr (NOTE 2)	Data (NOTE 3)
Read Array/Reset	1		Write	X	FFH			
Read Identifier Codes	≥ 2	4	Write	X	90H	Read	IA	ID
Read Status Register	2		Write	X	70H	Read	X	SRD
Clear Status Register	1		Write	X	50H			
Block Erase	2	5	Write	BA	20H	Write	BA	DOH
Word Write	2	5, 6	Write	WA	40H or 10H	Write	WA	WD
Block Erase and Word Write Suspend	1	5	Write	X	B0H			
Block Erase and Word Write Resume	1	5	Write	X	D0H			
Set Block Lock-Bit	2	7	Write	BA	60H	Write	BA	01H
Set Permanent Lock-Bit	2	7	Write	X	60H	Write	X	F1H
Clear Block Lock-Bits	2	8	Write	X	60H	Write	X	DOH

NOTES :

- Bus operations are defined in **Table 2**.
- X = Any valid address within the device.
IA = Identifier code address : see **Fig. 2**.
BA = Address within the block being erased or locked.
WA = Address of memory location to be written.
- SRD = Data read from status register. See **Table 6** for a description of the status register bits.
WD = Data to be written at location WA. Data is latched on the rising edge of WE# or CE# (whichever goes high first).
ID = Data read from identifier codes.
- Following the Read Identifier Codes command, read operations access manufacture, device, block lock, and permanent lock codes. See **Section 4.2** for read identifier code data.
- If the block is locked and the permanent lock-bit is not set, RP# must be at V_{HH} to enable block erase or word write operations. Attempts to issue a block erase or word write to a locked block while RP# is V_{HH}.
- Either 40H or 10H is recognized by the WSM as the word write setup.
- If the permanent lock-bit is set, RP# must be at V_{HH} to set a block lock-bit. RP# must be at V_{HH} to set the permanent lock-bit. If the permanent lock-bit is set, a block lock-bit cannot be set. Once the permanent lock-bit is set, permanent lock-bit reset is unable.
- If the permanent lock-bit is set, clear block lock-bits operation is unable. The clear block lock-bits operation simultaneously clears all block lock-bits. If the permanent lock-bit is not set, the Clear Block Lock-Bits command can be done while RP# is V_{HH}.
- Commands other than those shown above are reserved by SHARP for future device implementations and should not be used.

4.1 Read Array Command

Upon initial device power-up and after exit from deep power-down mode, the device defaults to read array mode. This operation is also initiated by writing the Read Array command. The device remains enabled for reads until another command is written. Once the internal WSM has started a block erase, word write or lock-bit configuration, the device will not recognize the Read Array command until the WSM completes its operation unless the WSM is suspended via an Erase Suspend or Word Write Suspend command. The Read Array command functions independently of the VPP voltage and RP# can be VIH or VHH.

4.2 Read Identifier Codes Command

The identifier code operation is initiated by writing the Read Identifier Codes command. Following the command write, read cycles from addresses shown in **Fig. 2** retrieve the manufacture, device, block lock configuration and permanent lock configuration codes (see **Table 4** for identifier code values). To terminate the operation, write another valid command. Like the Read Array command, the Read Identifier Codes command functions independently of the VPP voltage and RP# can be VIH or VHH. Following the Read Identifier Codes command, the following information can be read :

Table 4 Identifier Codes

CODE	ADDRESS	DATA
Manufacture Code	00000H	00B0H
Device Code	00001H	0050H
Block Lock Configuration (NOTE 2)	XX002H (NOTE 1)	
• Unlocked		DQ0 = 0
• Locked		DQ0 = 1
• Reserved for future enhancement		DQ1-15
Permanent Lock Configuration (NOTE 2)	00003H	
• Unlocked		DQ0 = 0
• Locked		DQ0 = 1
• Reserved for future enhancement		DQ1-15

NOTES :

1. X selects the specific block lock configuration code to be read. See **Fig. 2** for the device identifier code memory map.
2. Block lock status and permanent lock status are output by DQ0. DQ1-DQ15 are reserved for future enhancement.

4.3 Read Status Register Command

The status register may be read to determine when a block erase, word write, or lock-bit configuration is complete and whether the operation completed successfully. It may be read at any time by writing the Read Status Register command. After writing this command, all subsequent read operations output data from the status register until another valid command is written. The status register contents are latched on the falling edge of OE# or CE#, whichever occurs. OE# or CE# must toggle to VIH before further reads to update the status register latch. The Read Status Register command functions independently of the VPP voltage. RP# can be VIH or VHH.

4.4 Clear Status Register Command

Status register bits SR.5, SR.4, SR.3, and SR.1 are set to "1"s by the WSM and can only be reset by the Clear Status Register command. These bits indicate various failure conditions (see **Table 6**). By allowing system software to reset these bits, several operations (such as cumulatively erasing or locking multiple blocks or writing several words in sequence) may be performed. The status register may be polled to determine if an error occurred during the sequence.

To clear the status register, the Clear Status Register command (50H) is written. It functions independently of the applied VPP voltage. RP# can be VIH or VHH. This command is not functional during block erase or word write suspend modes.

4.5 Block Erase Command

Erase is executed one block at a time and initiated by a two-cycle command. A block erase setup is first written, followed by a block erase confirm. This command sequence requires appropriate sequencing and an address within the block to be erased (erase changes all block data to FFH). Block preconditioning, erase, and verify are handled internally by the WSM (invisible to the system). After the two-cycle block erase sequence is written,

the device automatically outputs status register data when read (see **Fig. 3**). The CPU can detect block erase completion by analyzing the output data of the RY/BY# pin or status register bit SR.7.

When the block erase is complete, status register bit SR.5 should be checked. If a block erase error is detected, the status register should be cleared before system software attempts corrective actions. The CUI remains in read status register mode until a new command is issued.

This two-step command sequence of set-up followed by execution ensures that block contents are not accidentally erased. An invalid Block Erase command sequence will result in both status register bits SR.4 and SR.5 being set to "1". Also, reliable block erasure can only occur when $V_{CC} = V_{CC1/2/3/4}$ and $V_{PP} = V_{PPH1/2/3}$. In the absence of this high voltage, block contents are protected against erasure. If block erase is attempted while $V_{PP} \leq V_{PPLK}$, SR.3 and SR.5 will be set to "1". Successful block erase requires that the corresponding block lock-bit be cleared or, if set, that $RP\# = V_{HH}$. If block erase is attempted when the corresponding block lock-bit is set and $RP\# = V_{IH}$, SR.1 and SR.5 will be set to "1". Once permanent lock-bit is set, the blocks which have been set block lock-bit are unable to erase forever. Block erase operations with $V_{IH} < RP\# < V_{HH}$ produce spurious results and should not be attempted.

4.6 Word Write Command

Word write is executed by a two-cycle command sequence. Word write setup (standard 40H or alternate 10H) is written, followed by a second write that specifies the address and data (latched on the rising edge of WE#). The WSM then takes over, controlling the word write and write verify algorithms internally. After the word write sequence is written, the device automatically outputs status register data when read (see **Fig. 4**). The CPU can detect the

completion of the word write event by analyzing the RY/BY# pin or status register bit SR.7.

When word write is complete, status register bit SR.4 should be checked. If word write error is detected, the status register should be cleared. The internal WSM verify only detects errors for "1"s that do not successfully write to "0"s. The CUI remains in read status register mode until it receives another command.

Reliable word writes can only occur when $V_{CC} = V_{CC1/2/3/4}$ and $V_{PP} = V_{PPH1/2/3}$. In the absence of this high voltage, memory contents are protected against word writes. If word write is attempted while $V_{PP} \leq V_{PPLK}$, status register bits SR.3 and SR.4 will be set to "1". Successful word write requires that the corresponding block lock-bit be cleared or, if set, that $RP\# = V_{HH}$. If word write is attempted when the corresponding block lock-bit is set and $RP\# = V_{IH}$, SR.1 and SR.4 will be set to "1". Once permanent lock-bit is set, the blocks which have been set block lock-bit are unable to write forever. Word write operations with $V_{IH} < RP\# < V_{HH}$ produce spurious results and should not be attempted.

4.7 Block Erase Suspend Command

The Block Erase Suspend command allows block erase interruption to read or word write data in another block of memory. Once the block erase process starts, writing the Block Erase Suspend command requests that the WSM suspend the block erase sequence at a predetermined point in the algorithm. The device outputs status register data when read after the Block Erase Suspend command is written. Polling status register bits SR.7 and SR.6 can determine when the block erase operation has been suspended (both will be set to "1"). RY/BY# will also transition to V_{OH} . Specification t_{WHRH2} defines the block erase suspend latency.

At this point, a Read Array command can be written to read data from blocks other than that which is suspended. A Word Write command sequence can also be issued during erase suspend to program data in other blocks. Using the Word Write Suspend command (see **Section 4.8**), a word write operation can also be suspended. During a word write operation with block erase suspended, status register bit SR.7 will return to "0" and the RY/BY# output will transition to VOL. However, SR.6 will remain "1" to indicate block erase suspend status.

The only other valid commands while block erase is suspended are Read Status Register and Block Erase Resume. After a Block Erase Resume command is written to the flash memory, the WSM will continue the block erase process. Status register bits SR.6 and SR.7 will automatically clear and RY/BY# will return to VOL. After the Erase Resume command is written, the device automatically outputs status register data when read (see **Fig. 5**). VPP must remain at VPPH1/2/3 (the same VPP level used for block erase) while block erase is suspended. RP# must also remain at VIH or VHH (the same RP# level used for block erase). Block erase cannot resume until word write operations initiated during block erase suspend have completed.

4.8 Word Write Suspend Command

The Word Write Suspend command allows word write interruption to read data in other flash memory locations. Once the word write process starts, writing the Word Write Suspend command requests that the WSM suspend the word write sequence at a predetermined point in the algorithm. The device continues to output status register data when read after the Word Write Suspend command is written. Polling status register bits SR.7 and SR.2 can determine when the word write operation has been suspended (both will be set to "1"). RY/BY# will also transition to VOH. Specification tWHRH1 defines the word write suspend latency.

At this point, a Read Array command can be written to read data from locations other than that which is suspended. The only other valid commands while word write is suspended are Read Status Register and Word Write Resume. After Word Write Resume command is written to the flash memory, the WSM will continue the word write process. Status register bits SR.2 and SR.7 will automatically clear and RY/BY# will return to VOL. After the Word Write Resume command is written, the device automatically outputs status register data when read (see **Fig. 6**). VPP must remain at VPPH1/2/3 (the same VPP level used for word write) while in word write suspend mode. RP# must also remain at VIH or VHH (the same RP# level used for word write).

4.9 Set Block and Permanent Lock-Bit Commands

The combination of the software command sequence and hardware RP# pin provides most flexible block lock (write protection) capability. The word write/block erase operation is restricted by the status of block lock-bit, RP# pin and permanent lock-bit. The status of RP# pin and permanent lock-bit restricts the set block bit. When the permanent lock-bit has not been set, and when RP# = VHH, the block lock bit can be set with the status of the RP# pin. When RP# = VHH, the permanent lock-bit can be set with the permanent lock-bit set command. After the permanent lock-bit has been set, the write/erase operation to the block lock-bit can never be accepted. Refer to **Table 5** for the hardware and the software write protection.

Set block lock-bit and permanent lock-bit are executed by a two-cycle command sequence. The set block or permanent lock-bit setup along with appropriate block or device address is written followed by either the set block lock-bit confirm (and an address within the block to be locked) or the set permanent lock-bit confirm (and any device address). The WSM then controls the set lock-bit algorithm. After the sequence is written, the device

automatically outputs status register data when read (see **Fig. 7**). The CPU can detect the completion of the set lock-bit event by analyzing the RY/BY# pin output or status register bit SR.7.

When the set lock-bit operation is complete, status register bit SR.4 should be checked. If an error is detected, the status register should be cleared. The CUI will remain in read status register mode until a new command is issued.

This two-step sequence of set-up followed by execution ensures that lock-bits are not accidentally set. An invalid Set Block or Permanent Lock-Bit command will result in status register bits SR.4 and SR.5 being set to "1". Also, reliable operations occur only when $V_{CC} = V_{CC1/2/3/4}$ and $V_{PP} = V_{PPH1/2/3}$. In the absence of this high voltage, lock-bit contents are protected against alteration.

A successful set block lock-bit operation requires that the permanent lock-bit be cleared and $RP\# = V_{HH}$. If it is attempted with the permanent lock-bit set, SR.1 and SR.4 will be set to "1" and the operation will fail. Set block lock-bit operations while $V_{IH} < RP\# < V_{HH}$ produce spurious results and should not be attempted. A successful set permanent lock-bit operation requires that $RP\# = V_{HH}$. If it is attempted with $RP\# = V_{IH}$, SR.1 and SR.4 will be set to "1" and the operation will fail. Set permanent lock-bit operations with $V_{IH} < RP\# < V_{HH}$ produce spurious results and should not be attempted.

4.10 Clear Block Lock-Bits Command

All set block lock-bits are cleared in parallel via the Clear Block Lock-Bits command. With the permanent lock-bit not set and $RP\# = V_{HH}$, block lock-bits can be cleared using the Clear Block Lock-Bits command. If the permanent lock-bit is set, clear block lock-bits operation is unable. See **Table 5** for a summary of hardware and software write protection options.

Clear block lock-bits option is executed by a two-cycle command sequence. A clear block lock-bits setup is first written. After the command is written, the device automatically outputs status register data when read (see **Fig. 8**). The CPU can detect completion of the clear block lock-bits event by analyzing the RY/BY# pin output or status register bit SR.7.

When the operation is complete, status register bit SR.5 should be checked. If a clear block lock-bits error is detected, the status register should be cleared. The CUI will remain in read status register mode until another command is issued.

This two-step sequence of set-up followed by execution ensures that block lock-bits are not accidentally cleared. An invalid Clear Block Lock-Bits command sequence will result in status register bits SR.4 and SR.5 being set to "1". Also, a reliable clear block lock-bits operation can only occur when $V_{CC} = V_{CC1/2/3/4}$ and $V_{PP} = V_{PPH1/2/3}$. In a clear block lock-bits operation is attempted while $V_{PP} \leq V_{PPLK}$, SR.3 and SR.5 will be set to "1". In the absence of this high voltage, the block lock-bit contents are protected against alteration. A successful clear block lock-bits operation requires that the permanent lock-bit is not set and $RP\# = V_{HH}$. If it is attempted with the permanent lock-bit set or $RP\# = V_{IH}$, SR.1 and SR.5 will be set to "1" and the operation will fail. A clear block lock-bits operation with $V_{IH} < RP\# < V_{HH}$ produce spurious results and should not be attempted.

If a clear block lock-bits operation is aborted due to V_{PP} or V_{CC} transition out of valid range or $RP\#$ active transition, block lock-bit values are left in an undetermined state. A repeat of clear block lock-bits is required to initialize block lock-bit contents to known values. Once the permanent lock-bit is set, it cannot be cleared.

Table 5 Write Protection Alternatives

OPERATION	PERMANENT LOCK-BIT	BLOCK LOCK-BIT	RP#	EFFECT
Block Erase or Word Write	X	0	V _{IH} or V _{HH}	Block Erase and Word Write Enabled
	0	1	V _{HH}	Block Lock-Bit Override. Block Erase and Word Write Enabled
			V _{IH}	Block is Locked. Block Erase and Word Write Disabled
			X	Permanent Lock-Bit is set. Block Erase and Word Write Disabled
Set Block Lock-Bit	0	X	V _{HH}	Set Block Lock-Bit Enabled
			V _{IH}	Set Block Lock-Bit Disabled
			X	Permanent Lock-Bit is set. Set Block Lock-Bit Disabled
Set Permanent Lock-Bit	X	X	V _{HH}	Set Permanent Lock-Bit Enabled
			V _{IH}	Set Permanent Lock-Bit Disabled
Clear Block Lock-Bits	0	X	V _{HH}	Clear Block Lock-Bits Enabled
			V _{IH}	Clear Block Lock-Bits Disabled
			X	Permanent Lock-Bit is set. Clear Block Lock-Bits Disabled

Table 6 Status Register Definition

WSMS	ESS	ECLBS	WWSLBS	VPPS	WWSS	DPS	R
7	6	5	4	3	2	1	0

<p>SR.7 = WRITE STATE MACHINE STATUS (WSMS) 1 = Ready 0 = Busy</p> <p>SR.6 = ERASE SUSPEND STATUS (ESS) 1 = Block Erase Suspended 0 = Block Erase in Progress/Completed</p> <p>SR.5 = ERASE AND CLEAR LOCK-BITS STATUS (ECLBS) 1 = Error in Block Erase or Clear Lock-Bits 0 = Successful Block Erase or Clear Lock-Bits</p> <p>SR.4 = WORD WRITE AND SET LOCK-BIT STATUS (WWSLBS) 1 = Error in Word Write or Set Permanent/Block Lock-Bit 0 = Successful Word Write or Set Permanent/Block Lock-Bit</p> <p>SR.3 = VPP STATUS (VPPS) 1 = VPP Low Detect, Operation Abort 0 = VPP OK</p> <p>SR.2 = WORD WRITE SUSPEND STATUS (WWSS) 1 = Word Write Suspended 0 = Word Write in Progress/Completed</p> <p>SR.1 = DEVICE PROTECT STATUS (DPS) 1 = Permanent Lock-Bit, Block Lock-Bit and/or RP# Lock Detected, Operation Abort 0 = Unlock</p> <p>SR.0 = RESERVED FOR FUTURE ENHANCEMENTS (R)</p>	<p>NOTES :</p> <p>Check RY/BY# or SR.7 to determine block erase, word write, or lock-bit configuration completion. SR.6-0 are invalid while SR.7 = "0".</p> <p>If both SR.5 and SR.4 are "1"s after a block erase or lock-bit configuration attempt, an improper command sequence was entered.</p> <p>SR.3 does not provide a continuous indication of VPP level. The WSM interrogates and indicates the VPP level only after Block Erase, Word Write, Set Block/Permanent Lock-Bit, or Clear Block Lock-Bits command sequences. SR.3 is not guaranteed to reports accurate feedback only when VPP ≠ VPPH1/2/3.</p> <p>SR.1 does not provide a continuous indication of permanent and block lock-bit values. The WSM interrogates the permanent lock-bit, block lock-bit, and RP# only after Block Erase, Word Write, or Lock-Bit configuration command sequences. It informs the system, depending on the attempted operation, if the block lock-bit is set, permanent lock-bit is set, and/or RP# is not V_{HH}. Reading the block lock and permanent lock configuration codes after writing the Read Identifier Codes command indicates permanent and block lock-bit status.</p> <p>SR.0 is reserved for future use and should be masked out when polling the status register.</p>
---	--

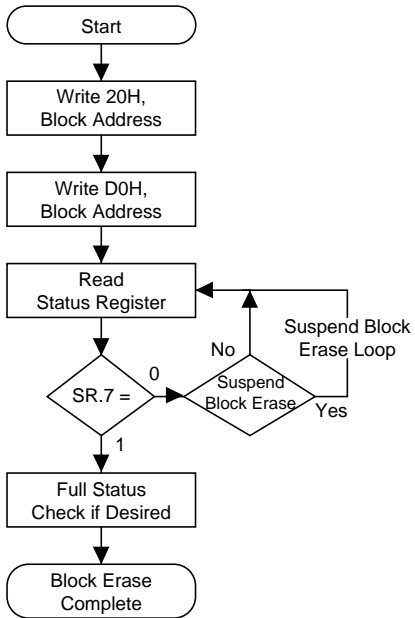

BUS OPERATION	COMMAND	COMMENTS
Write	Erase Setup	Data = 20H Addr = Within Block to be Erased
Write	Erase Confirm	Data = D0H Addr = Within Block to be Erased
Read		Status Register Data
Standby		Check SR.7 1 = WSM Ready 0 = WSM Busy
Repeat for subsequent block erasures.		
Full status check can be done after each block erase or after a sequence of block erasures.		
Write FFH after the last block erase operation to place device in read array mode.		

FULL STATUS CHECK PROCEDURE

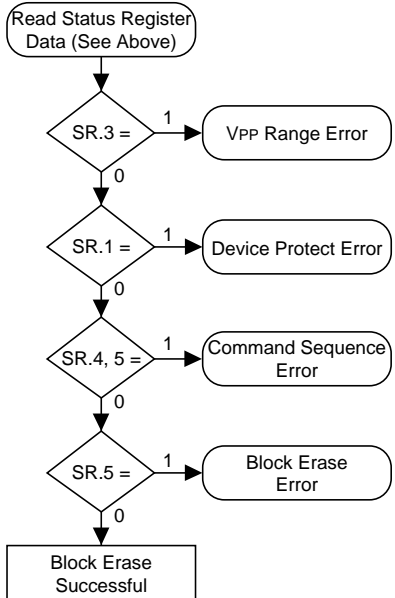

BUS OPERATION	COMMAND	COMMENTS
Standby		Check SR.3 1 = VPP Error Detect
Standby		Check SR.1 1 = Device Protect Detect RP# = VIH, Block Lock-Bit is Set Only required for systems implementing lock-bit configuration
Standby		Check SR.4, 5 Both 1 = Command Sequence Error
Standby		Check SR.5 1 = Block Erase Error
SR.5, SR.4, SR.3 and SR.1 are only cleared by the Clear Status Register command in cases where multiple blocks are erased before full status is checked.		
If error is detected, clear the status register before attempting retry or other error recovery.		

Fig. 3 Automated Block Erase Flowchart

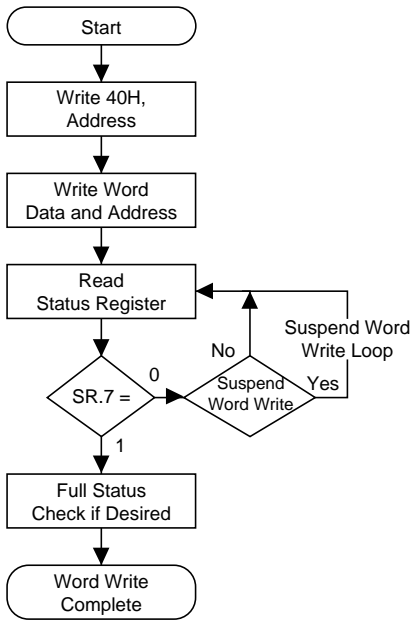

BUS OPERATION	COMMAND	COMMENTS
Write	Setup Word Write	Data = 40H Addr = Location to be Written
Write	Word Write	Data = Data to be Written Addr = Location to be Written
Read		Status Register Data
Standby		Check SR.7 1 = WSM Ready 0 = WSM Busy
Repeat for subsequent word writes.		
SR full status check can be done after each word write or after a sequence of word writes.		
Write FFH after the last word write operation to place device in read array mode.		

FULL STATUS CHECK PROCEDURE

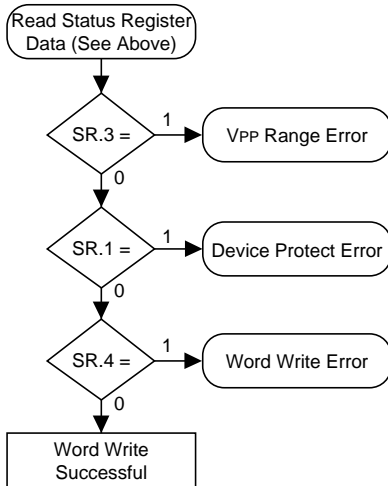

BUS OPERATION	COMMAND	COMMENTS
Standby		Check SR.3 1 = VPP Error Detect
Standby		Check SR.1 1 = Device Protect Detect RP# = VIH, Block Lock-Bit is Set Only required for systems implementing lock-bit configuration
Standby		Check SR.4 1 = Data Write Error
SR.4, SR.3 and SR.1 are only cleared by the Clear Status Register command in cases where multiple locations are written before full status is checked.		
If error is detected, clear the status register before attempting retry or other error recovery.		

Fig. 4 Automated Word Write Flowchart

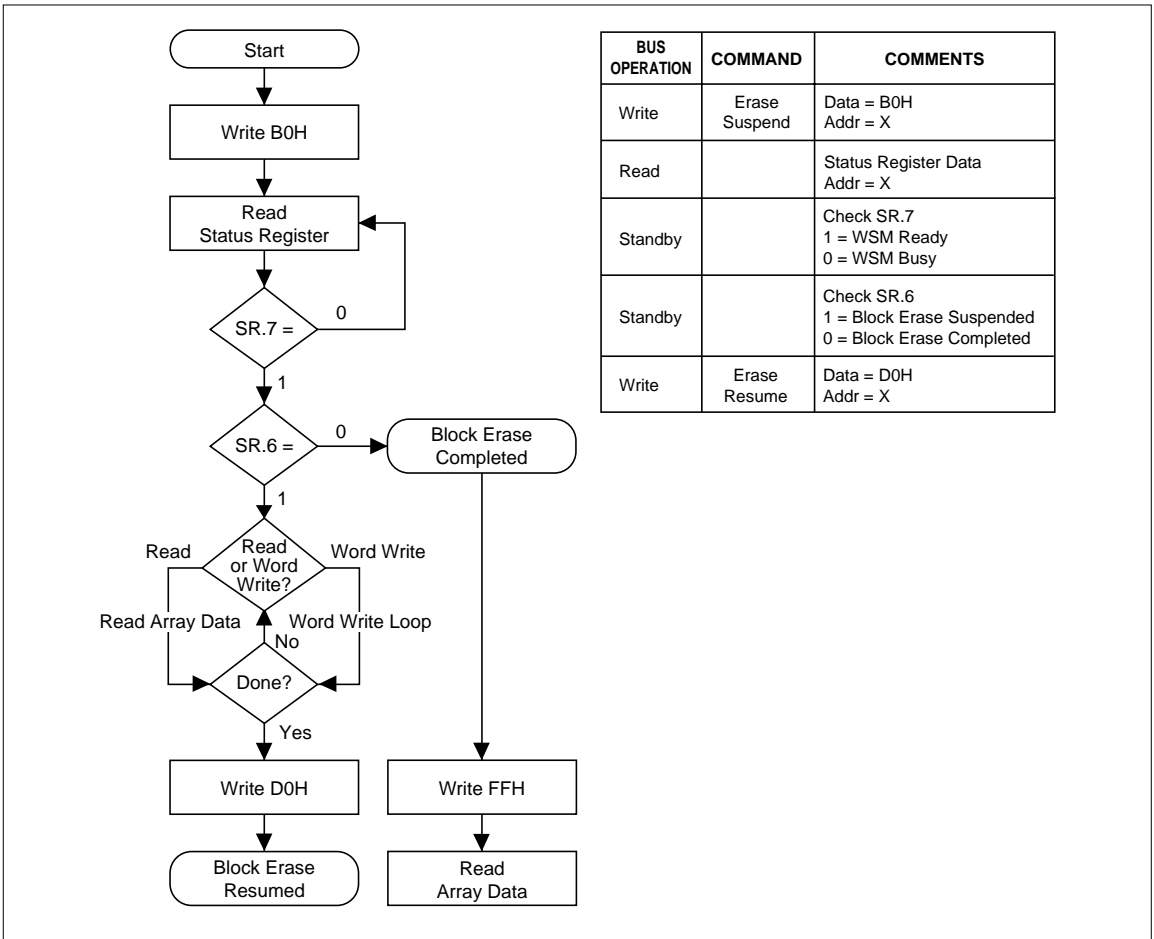

BUS OPERATION	COMMAND	COMMENTS
Write	Erase Suspend	Data = B0H Addr = X
Read		Status Register Data Addr = X
Standby		Check SR.7 1 = WSM Ready 0 = WSM Busy
Standby		Check SR.6 1 = Block Erase Suspended 0 = Block Erase Completed
Write	Erase Resume	Data = D0H Addr = X

Fig. 5 Block Erase Suspend/Resume Flowchart

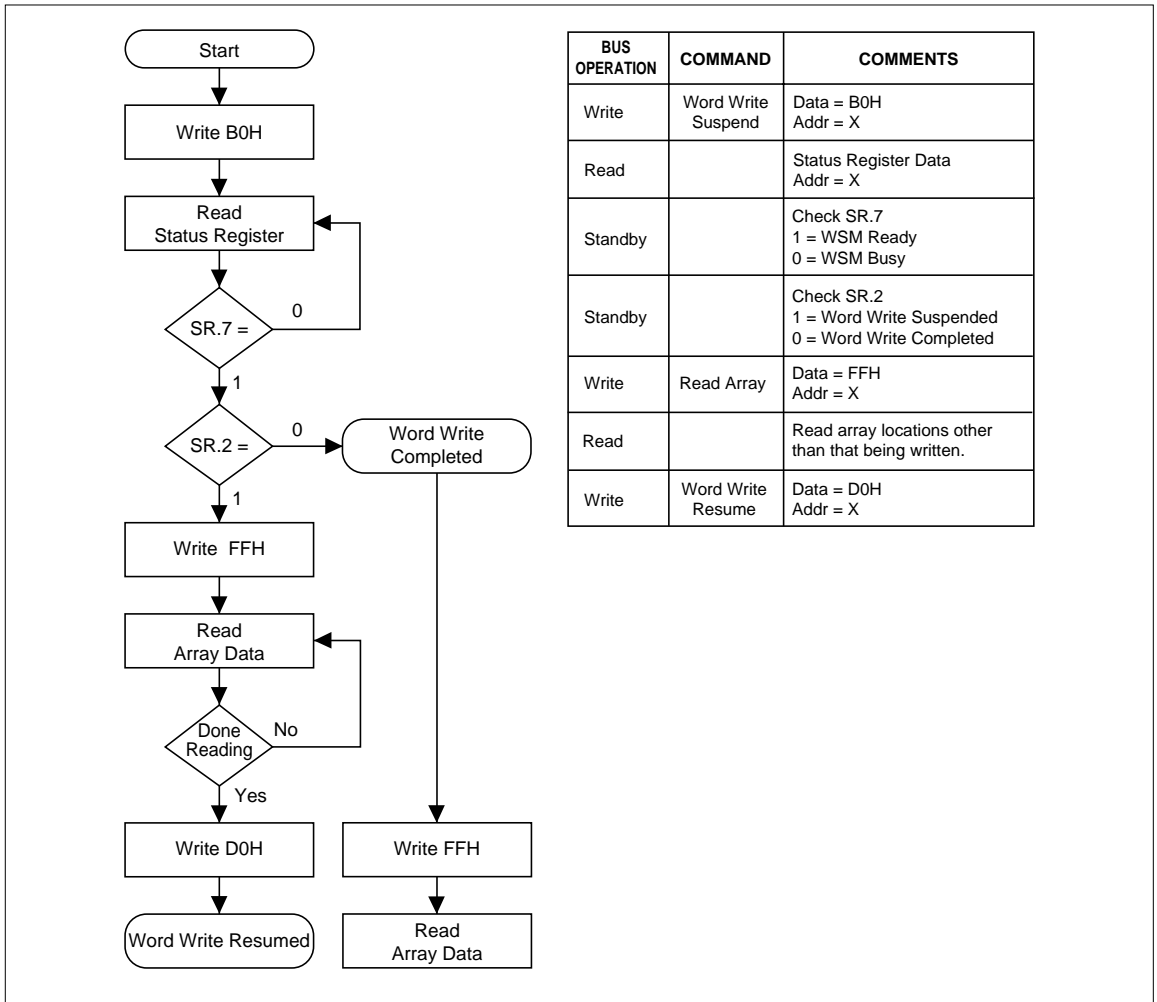

BUS OPERATION	COMMAND	COMMENTS
Write	Word Write Suspend	Data = B0H Addr = X
Read		Status Register Data Addr = X
Standby		Check SR.7 1 = WSM Ready 0 = WSM Busy
Standby		Check SR.2 1 = Word Write Suspended 0 = Word Write Completed
Write	Read Array	Data = FFH Addr = X
Read		Read array locations other than that being written.
Write	Word Write Resume	Data = D0H Addr = X

Fig. 6 Word Write Suspend/Resume Flowchart

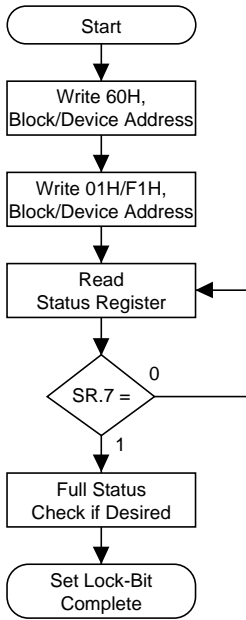

BUS OPERATION	COMMAND	COMMENTS
Write	Set Block/Permanent Lock-Bit Setup	Data = 60H Addr = Block Address (Block), Device Address (Permanent)
Write	Set Block or Permanent Lock-Bit Confirm	Data = 01H (Block), F1H (Permanent) Addr = Block Address (Block), Device Address (Permanent)
Read		Status Register Data
Standby		Check SR.7 1 = WSM Ready 0 = WSM Busy
Repeat for subsequent lock-bit set operations.		
Full status check can be done after each lock-bit set operation or after a sequence of lock-bit set operations.		
Write FFH after the last lock-bit set operation to place device in read array mode.		

FULL STATUS CHECK PROCEDURE

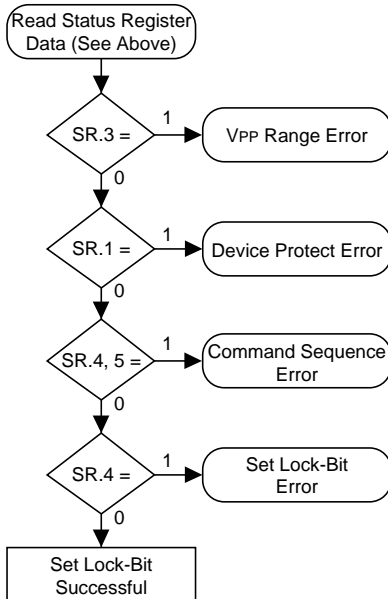

BUS OPERATION	COMMAND	COMMENTS
Standby		Check SR.3 1 = VPP Error Detect
Standby		Check SR.1 1 = Device Protect Detect RP# = VIH (Set Permanent Lock-Bit Operation) RP# = VIH or Permanent Lock-Bit is Set (Set Block Lock-Bit Operation)
Standby		Check SR.4, 5 Both 1 = Command Sequence Error
Standby		Check SR.4 1 = Set Lock-Bit Error
SR.5, SR.4, SR.3 and SR.1 are only cleared by the Clear Status Register command in cases where multiple lock-bits are set before full status is checked.		
If error is detected, clear the status register before attempting retry or other error recovery.		

Fig. 7 Set Block and Permanent Lock-Bit Flowchart

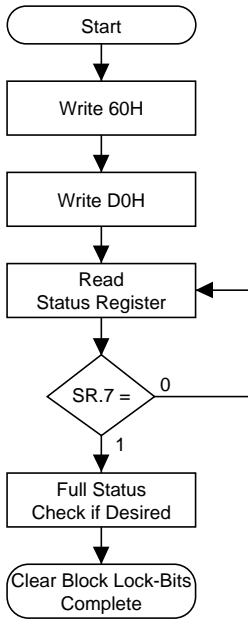

BUS OPERATION	COMMAND	COMMENTS
Write	Clear Block Lock-Bits Setup	Data = 60H Addr = X
Write	Clear Block Lock-Bits Confirm	Data = D0H Addr = X
Read		Status Register Data
Standby		Check SR.7 1 = WSM Ready 0 = WSM Busy
Write FFH after the last clear block lock-bits operation to place device in read array mode.		

FULL STATUS CHECK PROCEDURE

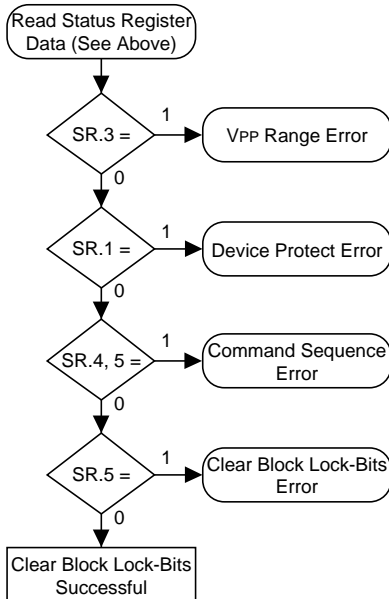

BUS OPERATION	COMMAND	COMMENTS
Standby		Check SR.3 1 = VPP Error Detect
Standby		Check SR.1 1 = Device Protect Detect RP# = VIH or Permanent Lock-Bit is Set
Standby		Check SR.4, 5 Both 1 = Command Sequence Error
Standby		Check SR.5 1 = Clear Block Lock-Bits Error
SR.5, SR.4, SR.3 and SR.1 are only cleared by the Clear Status Register command. If error is detected, clear the status register before attempting retry or other error recovery.		

Fig. 8 Clear Block Lock-Bits Flowchart

5 DESIGN CONSIDERATIONS

5.1 Three-Line Output Control

The device will often be used in large memory arrays. SHARP provides three control inputs to accommodate multiple memory connections. Three-line control provides for :

- a. Lowest possible memory power consumption.
- b. Complete assurance that data bus contention will not occur.

To use these control inputs efficiently, an address decoder should enable CE# while OE# should be connected to all memory devices and the system's READ# control line. This assures that only selected memory devices have active outputs while deselected memory devices are in standby mode. RP# should be connected to the system POWERGOOD signal to prevent unintended writes during system power transitions. POWERGOOD should also toggle during system reset.

5.2 RY/BY# and Block Erase, Word Write, and Lock-Bit Configuration Polling

RY/BY# is a full CMOS output that provides a hardware method of detecting block erase, word write and lock-bit configuration completion. It transitions low after block erase, word write, or lock-bit configuration commands and returns to VOH when the WSM has finished executing the internal algorithm.

RY/BY# can be connected to an interrupt input of the system CPU or controller. It is active at all times. RY/BY# is also VOH when the device is in block erase suspend (with word write inactive), word write suspend or deep power-down modes.

5.3 Power Supply Decoupling

Flash memory power switching characteristics require careful device decoupling. System designers are interested in three supply current

issues; standby current levels, active current levels and transient peaks produced by falling and rising edges of CE# and OE#. Transient current magnitudes depend on the device outputs' capacitive and inductive loading. Two-line control and proper decoupling capacitor selection will suppress transient voltage peaks. Each device should have a 0.1 μ F ceramic capacitor connected between its VCC and GND and between its VPP and GND. These high-frequency, low inductance capacitors should be placed as close as possible to package leads. Additionally, for every eight devices, a 4.7 μ F electrolytic capacitor should be placed at the array's power supply connection between VCC and GND. The bulk capacitor will overcome voltage slumps caused by PC board trace inductance.

5.4 VPP Trace on Printed Circuit Boards

Updating flash memories that reside in the target system requires that the printed circuit board designers pay attention to the VPP power supply trace. The VPP pin supplies the memory cell current for word writing and block erasing. Use similar trace widths and layout considerations given to the VCC power bus. Adequate VPP supply traces and decoupling will decrease VPP voltage spikes and overshoots.

5.5 VCC, VPP, RP# Transitions

Block erase, word write and lock-bit configuration are not guaranteed if VPP falls outside of a valid VPPH1/2/3 range, VCC falls outside of a valid VCC1/2/3/4 range, or RP# \neq VIH or VHH. If VPP error is detected, status register bit SR.3 is set to "1" along with SR.4 or SR.5, depending on the attempted operation. If RP# transitions to VIL during block erase, word write, or lock-bit configuration, RY/BY# will remain low until the reset operation is complete. Then, the operation will abort and the device will enter deep power-down. The aborted operation may leave data partially altered. Therefore, the command sequence must be

repeated after normal operation is restored. Device power-off or RP# transitions to V_{IL} clear the status register.

The CUI latches commands issued by system software and is not altered by V_{PP} or CE# transitions or WSM actions. Its state is read array mode upon power-up, after exit from deep power-down or after V_{CC} transitions below V_{LKO}.

After block erase, word write, or lock-bit configuration, even after V_{PP} transitions down to V_{PPLK}, the CUI must be placed in read array mode via the Read Array command if subsequent access to the memory array is desired.

5.6 Power-Up/Down Protection

The device is designed to offer protection against accidental block erasure, word writing, or lock-bit configuration during power transitions. Upon power-up, the device is indifferent as to which power supply (V_{PP} or V_{CC}) powers-up first. Internal circuitry resets the CUI to read array mode at power-up.

A system designer must guard against spurious writes for V_{CC} voltages above V_{LKO} when V_{PP} is active. Since both WE# and CE# must be low for a command write, driving either to V_{IH} will inhibit writes. The CUI's two-step command sequence architecture provides added level of protection against data alteration.

In-system block lock and unlock capability prevents inadvertent data alteration. The device is disabled while RP# = V_{IL} regardless of its control inputs state.

5.7 Power Consumption

When designing portable systems, designers must consider battery power consumption not only during device operation, but also for data retention during system idle time. Flash memory's nonvolatility increases usable battery life because data is retained when system power is removed.

In addition, deep power-down mode ensures extremely low power consumption even when system power is applied. For example, portable computing products and other power sensitive applications that use an array of devices for solid-state storage can consume negligible power by lowering RP# to V_{IL} standby or sleep modes. If access is again needed, the devices can be read following the t_{PHQV} and t_{PHWL} wake-up cycles required after RP# is first raised to V_{IH}. See **Section 6.2.4 through 6.2.6 "AC CHARACTERISTICS - READ-ONLY and WRITE OPERATIONS"** and **Fig. 13, Fig. 14 and Fig. 15** for more information.

6 ELECTRICAL SPECIFICATIONS

6.1 Absolute Maximum Ratings*

Operating Temperature

During Read, Block Erase, Word Write
and Lock-Bit Configuration..... 0 to +70°C (NOTE 1)
Temperature under Bias..... -10 to +80°C

Storage Temperature..... - 65 to +125°C

Voltage On Any Pin

(except V_{CC}, V_{PP}, and RP#) -2.0 to +7.0 V (NOTE 2)

V_{CC} Supply Voltage..... -2.0 to +7.0 V (NOTE 2)

V_{PP} Update Voltage during

Block Erase, Word Write and
Lock-Bit Configuration .. -2.0 to +14.0 V (NOTE 2, 3)

RP# Voltage with Respect to

GND during Lock-Bit
Configuration Operations.. -2.0 to +14.0 V (NOTE 2, 3)

Output Short Circuit Current 100 mA (NOTE 4)

NOTICE : The specifications are subject to change without notice. Verify with your local SHARP sales office that you have the latest datasheet before finalizing a design.

**WARNING* : Stressing the device beyond the "Absolute Maximum Ratings" may cause permanent damage. These are stress ratings only. Operation beyond the "Operating Conditions" is not recommended and extended exposure beyond the "Operating Conditions" may affect device reliability.

NOTES :

1. Operating temperature is for commercial product defined by this specification.
2. All specified voltages are with respect to GND. Minimum DC voltage is -0.5 V on input/output pins and -0.2 V on V_{CC} and V_{PP} pins. During transitions, this level may undershoot to -2.0 V for periods < 20 ns. Maximum DC voltage on input/output pins and V_{CC} is V_{CC}+0.5 V which, during transitions, may overshoot to V_{CC}+2.0 V for periods < 20 ns.
3. Maximum DC voltage on V_{PP} and RP# may overshoot to +14.0 V for periods < 20 ns.
4. Output shorted for no more than one second. No more than one output shorted at a time.

6.2 Operating Conditions

SYMBOL	PARAMETER	NOTE	MIN.	MAX.	UNIT	VERSION
T _A	Operating Temperature	1	0	+70	°C	
V _{CC1}	V _{CC} Supply Voltage (2.7 to 3.0 V)		2.7	3.0	V	
V _{CC2}	V _{CC} Supply Voltage (3.3±0.3 V)		3.0	3.6	V	
V _{CC3}	V _{CC} Supply Voltage (5.0±0.25 V)		4.75	5.25	V	LH28F800SG-L70
V _{CC4}	V _{CC} Supply Voltage (5.0±0.5 V)		4.50	5.50	V	

NOTE :

1. Test condition : Ambient temperature

6.2.1 CAPACITANCE (NOTE 1)

T_A = +25°C, f = 1 MHz

SYMBOL	PARAMETER	TYP.	MAX.	UNIT	CONDITION
C _{IN}	Input Capacitance	7	10	pF	V _{IN} = 0.0 V
C _{OUT}	Output Capacitance	9	12	pF	V _{OUT} = 0.0 V

NOTE :

1. Sampled, not 100% tested.

6.2.2 AC INPUT/OUTPUT TEST CONDITIONS

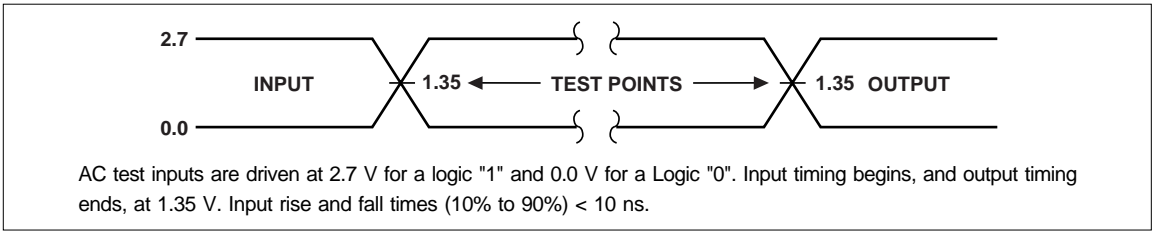

Fig. 9 Transient Input/Output Reference Waveform for $V_{CC} = 2.7$ to 3.0 V

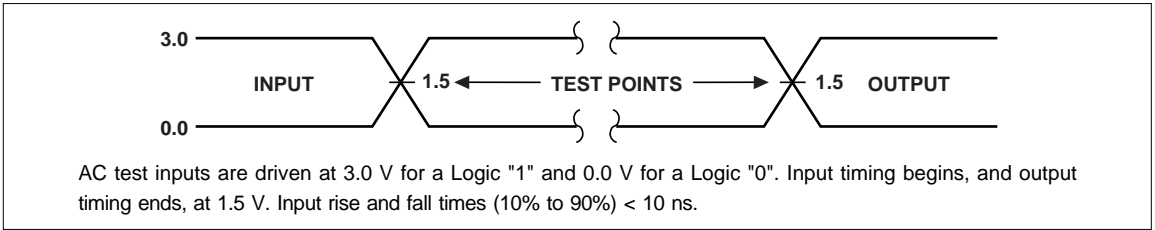

Fig. 10 Transient Input/Output Reference Waveform for $V_{CC} = 3.3 \pm 0.3$ V and $V_{CC} = 5.0 \pm 0.25$ V (High Speed Testing Configuration)

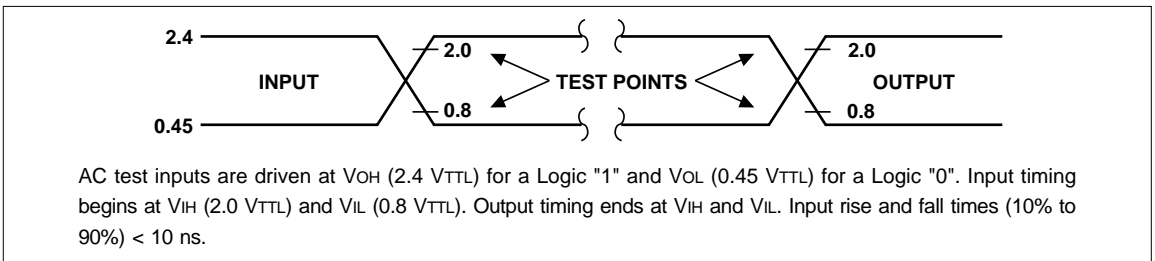

Fig. 11 Transient Input/Output Reference Waveform for $V_{CC} = 5.0 \pm 0.5$ V (Standard Testing Configuration)

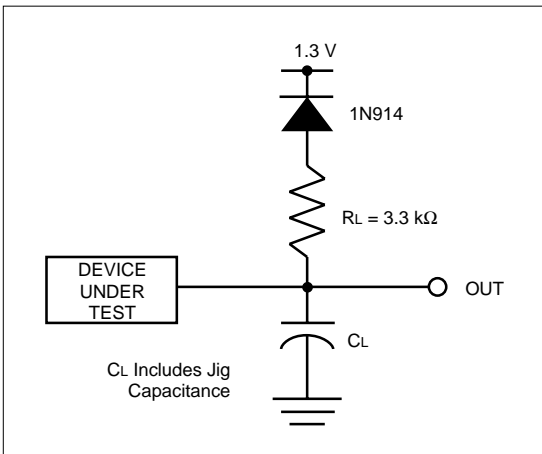

Fig. 12 Transient Equivalent Testing Load Circuit

Test Configuration Capacitance Loading Value

TEST CONFIGURATION	C_L (pF)
$V_{CC} = 3.3 \pm 0.3$ V, 2.7 to 3.0 V	50
$V_{CC} = 5.0 \pm 0.25$ V (NOTE 1)	30
$V_{CC} = 5.0 \pm 0.5$ V	100

NOTE :

1. Applied to high-speed product, LH28F800SG-L70.

6.2.3 DC CHARACTERISTICS

SYMBOL	PARAMETER	NOTE	Vcc = 2.7 to 3.6 V		Vcc = 5.0±0.5 V		UNIT	TEST CONDITIONS
			TYP.	MAX.	TYP.	MAX.		
ILI	Input Load Current	1		±0.5		±1	μA	Vcc = Vcc Max. VIN = Vcc or GND
ILO	Output Leakage Current	1		±0.5		±10	μA	Vcc = Vcc Max. VOUT = Vcc or GND
Iccs	Vcc Standby Current	1, 3, 6		100		100	μA	CMOS inputs Vcc = Vcc Max. CE# = RP# = Vcc±0.2 V
				2		2	mA	TTL inputs Vcc = Vcc Max. CE# = RP# = VIH
Iccd	Vcc Deep Power-Down Current	1		12		16	μA	RP# = GND±0.2 V IOUT (RY/BY#) = 0 mA
Iccr	Vcc Read Current	1, 5, 6		25		50	mA	CMOS inputs Vcc = Vcc Max. CE# = GND f = 5 MHz (3.3 V, 2.7 V), 8 MHz (5 V) IOUT = 0 mA
				30		65	mA	TTL inputs Vcc = Vcc Max. CE# = GND f = 5 MHz (3.3 V, 2.7 V), 8 MHz (5 V) IOUT = 0 mA
Iccw	Vcc Word Write or Set Lock-Bit Current	1, 7		17	—	—	mA	VPP = 2.7 to 3.6 V
				17		35	mA	VPP = 5.0±0.5 V
				12		30	mA	VPP = 12.0±0.6 V
Icce	Vcc Block Erase or Clear Block Lock-Bits Current	1, 7		17	—	—	mA	VPP = 2.7 to 3.6 V
				17		30	mA	VPP = 5.0±0.5 V
				12		25	mA	VPP = 12.0±0.6 V
Iccws	Vcc Word Write or Block Erase Suspend Current	1, 2		6		10	mA	CE# = VIH
Icces								
IPPS	VPP Standby or Read Current	1		±15		±15	μA	VPP ≤ Vcc
				200		200	μA	VPP > Vcc
IPPD	VPP Deep Power-Down Current	1		5		5	μA	RP# = GND±0.2 V
IPPW	VPP Word Write or Set Lock-Bit Current	1, 7		80	—	—	mA	VPP = 2.7 to 3.6 V
				80		80	mA	VPP = 5.0±0.5 V
				30		30	mA	VPP = 12.0±0.6 V
IPPE	VPP Block Erase or Clear Block Lock-Bits Current	1, 7		40	—	—	mA	VPP = 2.7 to 3.6 V
				40		40	mA	VPP = 5.0±0.5 V
				30		30	mA	VPP = 12.0±0.6 V
IPPWS	VPP Word Write or Block Erase Suspend Current	1		200		200	μA	VPP = VPPH1/2/3
IPPEs								

6.2.3 DC CHARACTERISTICS (contd.)

SYMBOL	PARAMETER	NOTE	V _{CC} = 2.7 to 3.6 V		V _{CC} = 5.0±0.5 V		UNIT	TEST CONDITIONS
			MIN.	MAX.	MIN.	MAX.		
V _{IL}	Input Low Voltage	7	-0.5	0.8	-0.5	0.8	V	
V _{IH}	Input High Voltage	7	2.0	V _{CC} +0.5	2.0	V _{CC} +0.5	V	
V _{OL}	Output Low Voltage	3, 7		0.4		0.45	V	V _{CC} = V _{CC} Min. I _{OL} = 5.8 mA (V _{CC} = 5 V), I _{OL} = 2.0 mA (V _{CC} = 3.3 V, 2.7 V)
V _{OH1}	Output High Voltage (TTL)	3, 7	2.4		2.4		V	V _{CC} = V _{CC} Min. I _{OH} = -2.5 mA (V _{CC} = 5 V), I _{OH} = -2.0 mA (V _{CC} = 3.3 V, 2.7 V)
V _{OH2}	Output High Voltage (CMOS)	3, 7	0.85		0.85		V	V _{CC} = V _{CC} Min. I _{OH} = -2.5 μA
			V _{CC}		V _{CC}		V	V _{CC} = V _{CC} Min. I _{OH} = -100 μA
V _{PPLK}	V _{PP} Lockout Voltage during Normal Operations	4, 7		1.5		1.5	V	
V _{PPH1}	V _{PP} Voltage during Word Write, Block Erase or Lock-Bit Operations		2.7	3.6	—	—	V	
V _{PPH2}	V _{PP} Voltage during Word Write, Block Erase or Lock-Bit Operations		4.5	5.5	4.5	5.5	V	
V _{PPH3}	V _{PP} Voltage during Word Write, Block Erase or Lock-Bit Operations		11.4	12.6	11.4	12.6	V	
V _{LKO}	V _{CC} Lockout Voltage		2.0		2.0		V	
V _{HH}	RP# Unlock Voltage	8	11.4	12.6	11.4	12.6	V	Set permanent lock-bit Override block lock-bit

NOTES :

- All currents are in RMS unless otherwise noted. Typical values at nominal V_{CC} voltage and T_A = +25°C. These currents are valid for all product versions (packages and speeds).
- I_{CCWS} and I_{CCES} are specified with the device deselected. If reading or word writing in erase suspend mode, the device's current draw is the sum of I_{CCWS} or I_{CCES} and I_{CCR} or I_{CCW}, respectively.
- Includes RY/BY#.
- Block erases, word writes, and lock-bit configurations are inhibited when V_{PP} ≤ V_{PPLK}, and not guaranteed in the range between V_{PPLK} (max.) and V_{PPH1} (min.), between V_{PPH1} (max.) and V_{PPH2} (min.), between V_{PPH2} (max.) and V_{PPH3} (min.), and above V_{PPH3} (max.).
- Automatic Power Saving (APS) reduces typical I_{CCR} to 1 mA at 5 V V_{CC} and 3 mA at 2.7 to 3.6 V V_{CC} in static operation.
- CMOS inputs are either V_{CC}±0.2 V or GND±0.2 V. TTL inputs are either V_{IL} or V_{IH}.
- Sampled, not 100% tested.
- Permanent lock-bit set operations are inhibited when RP# = V_{IH}. Block lock-bit configuration operations are inhibited when the permanent lock-bit is set or RP# = V_{IH}. Block erases and word writes are inhibited when the corresponding block lock-bit is set and RP# = V_{IH} or the permanent lock-bit is set. Block erase, word write, and lock-bit configuration operations are not guaranteed with V_{IH} < RP# < V_{HH} and should not be attempted.

6.2.4 AC CHARACTERISTICS - READ-ONLY OPERATIONS (NOTE 1)

• Vcc = 2.7 to 3.0 V, TA = 0 to +70°C

VERSIONS			LH28F800SG-L70		LH28F800SG-L10		UNIT
SYMBOL	PARAMETER	NOTE	MIN.	MAX.	MIN.	MAX.	
tAVAV	Read Cycle Time		100		120		ns
tAVQV	Address to Output Delay			100		120	ns
tELQV	CE# to Output Delay	2		100		120	ns
tPHQV	RP# High to Output Delay			600		600	ns
tGLQV	OE# to Output Delay	2		45		55	ns
tELQX	CE# to Output in Low Z	3	0		0		ns
tEHQZ	CE# High to Output in High Z	3		45		55	ns
tGLQX	OE# to Output in Low Z	3	0		0		ns
tGHQZ	OE# High to Output in High Z	3		20		25	ns
tOH	Output Hold from Address, CE# or OE# Change, Whichever Occurs First	3	0		0		ns

• Vcc = 3.3±0.3 V, TA = 0 to +70°C

VERSIONS			LH28F800SG-L70		LH28F800SG-L10		UNIT
SYMBOL	PARAMETER	NOTE	MIN.	MAX.	MIN.	MAX.	
tAVAV	Read Cycle Time		85		100		ns
tAVQV	Address to Output Delay			85		100	ns
tELQV	CE# to Output Delay	2		85		100	ns
tPHQV	RP# High to Output Delay			600		600	ns
tGLQV	OE# to Output Delay	2		40		45	ns
tELQX	CE# to Output in Low Z	3	0		0		ns
tEHQZ	CE# High to Output in High Z	3		40		45	ns
tGLQX	OE# to Output in Low Z	3	0		0		ns
tGHQZ	OE# High to Output in High Z	3		15		20	ns
tOH	Output Hold from Address, CE# or OE# Change, Whichever Occurs First	3	0		0		ns

NOTES :

1. See AC Input/Output Reference Waveform (Fig. 9 through Fig. 11) for maximum allowable input slew rate.
2. OE# may be delayed up to tELQV-tGLQV after the falling edge of CE# without impact on tELQV.
3. Sampled, not 100% tested.

6.2.4 AC CHARACTERISTICS - READ-ONLY OPERATIONS (contd.) (NOTE 1)

• $V_{CC} = 5.0 \pm 0.25 \text{ V}$, $5.0 \pm 0.5 \text{ V}$, $T_A = 0 \text{ to } +70^\circ\text{C}$

VERSIONS		V _{CC} ±0.25 V	(NOTE 4) LH28F800SG-L70		(NOTE 5) LH28F800SG-L70		(NOTE 5) LH28F800SG-L10		UNIT
			V _{CC} ±0.5 V		MIN.	MAX.	MIN.	MAX.	
SYMBOL	PARAMETER	NOTE	MIN.	MAX.	MIN.	MAX.	MIN.	MAX.	
t _{AVAV}	Read Cycle Time		70		80		100		ns
t _{AVQV}	Address to Output Delay			70		80		100	ns
t _{ELQV}	CE# to Output Delay	2		70		80		100	ns
t _{PHQV}	RP# High to Output Delay			400		400		400	ns
t _{GLQV}	OE# to Output Delay	2		40		45		50	ns
t _{ELQX}	CE# to Output in Low Z	3	0		0		0		ns
t _{EHQZ}	CE# High to Output in High Z	3		55		55		55	ns
t _{GLQX}	OE# to Output in Low Z	3	0		0		0		ns
t _{GHQZ}	OE# High to Output in High Z	3		10		10		15	ns
t _{OH}	Output Hold from Address, CE# or OE# Change, Whichever Occurs First	3	0		0		0		ns

NOTES :

1. See AC Input/Output Reference Waveform (Fig. 9 through Fig. 11) for maximum allowable input slew rate.
2. OE# may be delayed up to t_{ELQV}-t_{GLQV} after the falling edge of CE# without impact on t_{ELQV}.
3. Sampled, not 100% tested.
4. See Fig. 10 "Transient Input/Output Reference Waveform" and Fig. 12 "Transient Equivalent Testing Load Circuit" (High Speed Configuration) for testing characteristics.
5. See Fig. 11 "Transient Input/Output Reference Waveform" and Fig. 12 "Transient Equivalent Testing Load Circuit" (Standard Configuration) for testing characteristics.

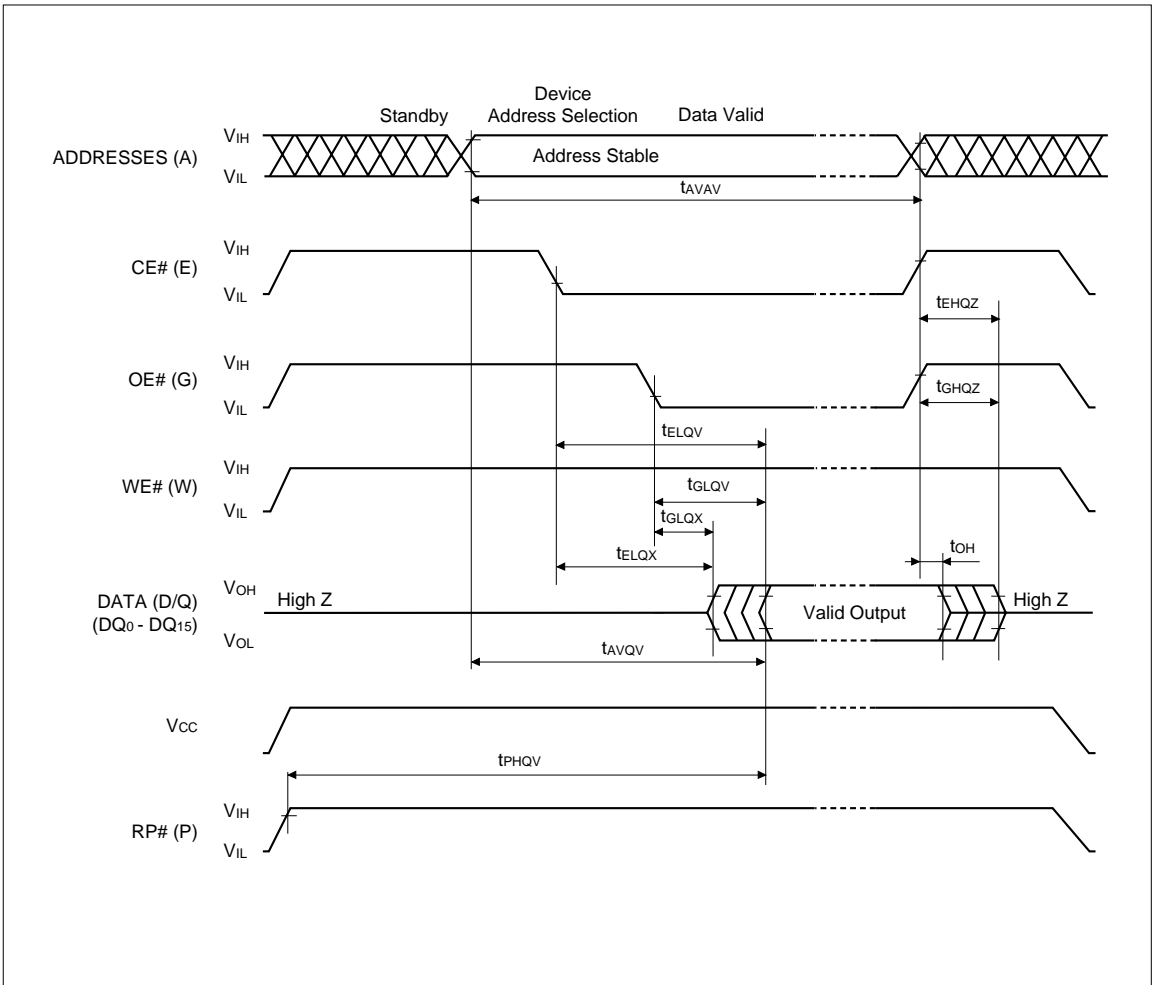

Fig. 13 AC Waveform for Read Operations

6.2.5 AC CHARACTERISTICS FOR WE#-CONTROLLED WRITE OPERATIONS (NOTE 1)

• Vcc = 2.7 to 3.0 V, TA = 0 to +70°C

VERSIONS			LH28F800SG-L70		LH28F800SG-L10		UNIT
SYMBOL	PARAMETER	NOTE	MIN.	MAX.	MIN.	MAX.	
tAVAV	Write Cycle Time		100		120		ns
tPHWL	RP# High Recovery to WE# Going Low	2	1		1		µs
tELWL	CE# Setup to WE# Going Low		10		10		ns
tWLWH	WE# Pulse Width		50		50		ns
tPHHWH	RP# V _{HH} Setup to WE# Going High	2	100		100		ns
tVPWH	V _{PP} Setup to WE# Going High	2	100		100		ns
tAVWH	Address Setup to WE# Going High	3	50		50		ns
tDVWH	Data Setup to WE# Going High	3	50		50		ns
tWHDX	Data Hold from WE# High		5		5		ns
tWHAX	Address Hold from WE# High		5		5		ns
tWHEH	CE# Hold from WE# High		10		10		ns
tWHWL	WE# Pulse Width High		30		30		ns
tWHRL	WE# High to RY/BY# Going Low			100		100	ns
tWHGL	Write Recovery before Read		0		0		ns
tQVVL	V _{PP} Hold from Valid SRD, RY/BY# High	2, 4	0		0		ns
tQVPH	RP# V _{HH} Hold from Valid SRD, RY/BY# High	2, 4	0		0		ns

• Vcc = 3.3±0.3 V, TA = 0 to +70°C

VERSIONS			LH28F800SG-L70		LH28F800SG-L10		UNIT
SYMBOL	PARAMETER	NOTE	MIN.	MAX.	MIN.	MAX.	
tAVAV	Write Cycle Time		85		100		ns
tPHWL	RP# High Recovery to WE# Going Low	2	1		1		µs
tELWL	CE# Setup to WE# Going Low		10		10		ns
tWLWH	WE# Pulse Width		50		50		ns
tPHHWH	RP# V _{HH} Setup to WE# Going High	2	100		100		ns
tVPWH	V _{PP} Setup to WE# Going High	2	100		100		ns
tAVWH	Address Setup to WE# Going High	3	50		50		ns
tDVWH	Data Setup to WE# Going High	3	50		50		ns
tWHDX	Data Hold from WE# High		5		5		ns
tWHAX	Address Hold from WE# High		5		5		ns
tWHEH	CE# Hold from WE# High		10		10		ns
tWHWL	WE# Pulse Width High		30		30		ns
tWHRL	WE# High to RY/BY# Going Low			100		100	ns
tWHGL	Write Recovery before Read		0		0		ns
tQVVL	V _{PP} Hold from Valid SRD, RY/BY# High	2, 4	0		0		ns
tQVPH	RP# V _{HH} Hold from Valid SRD, RY/BY# High	2, 4	0		0		ns

NOTES :

1. Read timing characteristics during block erase, word write and lock-bit configuration operations are the same as during read-only operations. Refer to **Section 6.2.4 "AC CHARACTERISTICS"** for read-only operations.
2. Sampled, not 100% tested.
3. Refer to **Table 3** for valid A_{IN} and D_{IN} for block erase, word write, or lock-bit configuration.
4. V_{PP} should be held at V_{PPH1/2/3} (and if necessary RP# should be held at V_{HH}) until determination of block erase, word write, or lock-bit configuration success (SR.1/3/4/5 = 0).

6.2.5 AC CHARACTERISTICS FOR WE#-CONTROLLED WRITE OPERATIONS (contd.) (NOTE 1)

• $V_{CC} = 5.0 \pm 0.25 \text{ V}, 5.0 \pm 0.5 \text{ V}, T_A = 0 \text{ to } +70^\circ\text{C}$

VERSIONS		$V_{CC} \pm 0.25 \text{ V}$	(NOTE 5) LH28F800SG-L70		(NOTE 6) LH28F800SG-L70		(NOTE 6) LH28F800SG-L10		UNIT
		$V_{CC} \pm 0.5 \text{ V}$	MIN.	MAX.	MIN.	MAX.	MIN.	MAX.	
SYMBOL	PARAMETER	NOTE	MIN.	MAX.	MIN.	MAX.	MIN.	MAX.	
t _{AVAV}	Write Cycle Time		70		80		100		ns
t _{PHWL}	RP# High Recovery to WE# Going Low	2	1		1		1		μs
t _{ELWL}	CE# Setup to WE# Going Low		10		10		10		ns
t _{WLWH}	WE# Pulse Width		40		40		40		ns
t _{PHWH}	RP# V _{HH} Setup to WE# Going High	2	100		100		100		ns
t _{VPWH}	V _{PP} Setup to WE# Going High	2	100		100		100		ns
t _{AVWH}	Address Setup to WE# Going High	3	40		40		40		ns
t _{DVWH}	Data Setup to WE# Going High	3	40		40		40		ns
t _{WHDX}	Data Hold from WE# High		5		5		5		ns
t _{WHAX}	Address Hold from WE# High		5		5		5		ns
t _{WHEH}	CE# Hold from WE# High		10		10		10		ns
t _{WHWL}	WE# Pulse Width High		30		30		30		ns
t _{WHRL}	WE# High to RY/BY# Going Low			90		90		90	ns
t _{WHGL}	Write Recovery before Read		0		0		0		ns
t _{QVVL}	V _{PP} Hold from Valid SRD, RY/BY# High	2, 4	0		0		0		ns
t _{QVPH}	RP# V _{HH} Hold from Valid SRD, RY/BY# High	2, 4	0		0		0		ns

NOTES :

1. Read timing characteristics during block erase, word write and lock-bit configuration operations are the same as during read-only operations. Refer to **Section 6.2.4 "AC CHARACTERISTICS"** for read-only operations.
2. Sampled, not 100% tested.
3. Refer to **Table 3** for valid A_{IN} and D_{IN} for block erase, word write, or lock-bit configuration.
4. V_{PP} should be held at V_{PPH1/2/3} (and if necessary RP# should be held at V_{HH}) until determination of block erase, word write, or lock-bit configuration success (SR.1/3/4/5 = 0).
5. See **Fig. 10 "Transient Input/Output Reference Waveform"** and **Fig. 12 "Transient Equivalent Testing Load Circuit"** (High Speed Configuration) for testing characteristics.
6. See **Fig. 11 "Transient Input/Output Reference Waveform"** and **Fig. 12 "Transient Equivalent Testing Load Circuit"** (Standard Configuration) for testing characteristics.

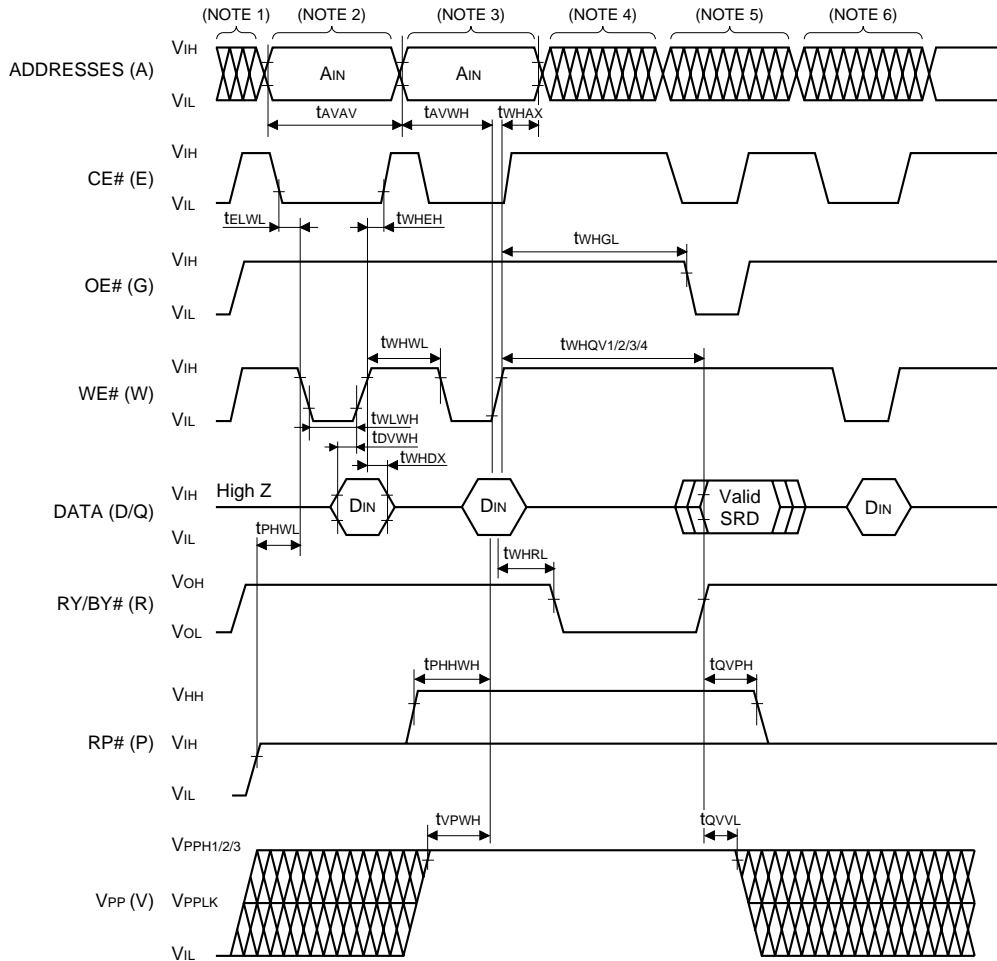

NOTES :

1. Vcc power-up and standby.
2. Write block erase or word write setup.
3. Write block erase confirm or valid address and data.
4. Automated erase or program delay.
5. Read status register data.
6. Write Read Array command.

Fig. 14 AC Waveform for WE#-Controlled Write Operations

6.2.6 AC CHARACTERISTICS FOR CE#-CONTROLLED WRITES OPERATIONS (NOTE 1)

• V_{CC} = 2.7 to 3.0 V, T_A = 0 to +70°C

VERSIONS			LH28F800SG-L70		LH28F800SG-L10		UNIT
SYMBOL	PARAMETER	NOTE	MIN.	MAX.	MIN.	MAX.	
tAVAV	Write Cycle Time		100		120		ns
tPHL	RP# High Recovery to CE# Going Low	2	1		1		µs
tWLEL	WE# Setup to CE# Going Low		0		0		ns
tELEH	CE# Pulse Width		70		70		ns
tPHHEH	RP# V _{HH} Setup to CE# Going High	2	100		100		ns
tVPEH	V _{PP} Setup to CE# Going High	2	100		100		ns
tAVEH	Address Setup to CE# Going High	3	50		50		ns
tDVEH	Data Setup to CE# Going High	3	50		50		ns
tEHD	Data Hold from CE# High		5		5		ns
tEHAX	Address Hold from CE# High		5		5		ns
tEHW	WE# Hold from CE# High		0		0		ns
tEHEL	CE# Pulse Width High		25		25		ns
tEHL	CE# High to RY/BY# Going Low			100		100	ns
tEHL	Write Recovery before Read		0		0		ns
tQVVL	V _{PP} Hold from Valid SRD, RY/BY# High	2, 4	0		0		ns
tQVPH	RP# V _{HH} Hold from Valid SRD, RY/BY# High	2, 4	0		0		ns

• V_{CC} = 3.3±0.3 V, T_A = 0 to +70°C

VERSIONS			LH28F800SG-L70		LH28F800SG-L10		UNIT
SYMBOL	PARAMETER	NOTE	MIN.	MAX.	MIN.	MAX.	
tAVAV	Write Cycle Time		85		100		ns
tPHL	RP# High Recovery to CE# Going Low	2	1		1		µs
tWLEL	WE# Setup to CE# Going Low		0		0		ns
tELEH	CE# Pulse Width		70		70		ns
tPHHEH	RP# V _{HH} Setup to CE# Going High	2	100		100		ns
tVPEH	V _{PP} Setup to CE# Going High	2	100		100		ns
tAVEH	Address Setup to CE# Going High	3	50		50		ns
tDVEH	Data Setup to CE# Going High	3	50		50		ns
tEHD	Data Hold from CE# High		5		5		ns
tEHAX	Address Hold from CE# High		5		5		ns
tEHW	WE# Hold from CE# High		0		0		ns
tEHEL	CE# Pulse Width High		25		25		ns
tEHL	CE# High to RY/BY# Going Low			100		100	ns
tEHL	Write Recovery before Read		0		0		ns
tQVVL	V _{PP} Hold from Valid SRD, RY/BY# High	2, 4	0		0		ns
tQVPH	RP# V _{HH} Hold from Valid SRD, RY/BY# High	2, 4	0		0		ns

NOTES :

- In systems where CE# defines the write pulse width (within a longer WE# timing waveform), all setup, hold, and inactive WE# times should be measured relative to the CE# waveform.
- Sampled, not 100% tested.
- Refer to **Table 3** for valid A_{IN} and D_{IN} for block erase, word write, or lock-bit configuration.
- V_{PP} should be held at V_{PPH1/2/3} (and if necessary RP# should be held at V_{HH}) until determination of block erase, word write, or lock-bit configuration success (SR.1/3/4/5 = 0).

6.2.6 AC CHARACTERISTICS FOR CE#-CONTROLLED WRITES OPERATIONS (contd.) (NOTE 1)

• $V_{CC} = 5.0 \pm 0.25 \text{ V}$, $5.0 \pm 0.5 \text{ V}$, $T_A = 0 \text{ to } +70^\circ\text{C}$

VERSIONS		$V_{CC} \pm 0.25 \text{ V}$	(NOTE 5) LH28F800SG-L70		(NOTE 6) LH28F800SG-L70		(NOTE 6) LH28F800SG-L10		UNIT
		$V_{CC} \pm 0.5 \text{ V}$	MIN.	MAX.	MIN.	MAX.	MIN.	MAX.	
SYMBOL	PARAMETER	NOTE	MIN.	MAX.	MIN.	MAX.	MIN.	MAX.	
t _{AVAV}	Write Cycle Time		70		80		100		ns
t _{PHEL}	RP# High Recovery to CE# Going Low	2	1		1		1		μs
t _{WLEL}	WE# Setup to CE# Going Low		0		0		0		ns
t _{ELEH}	CE# Pulse Width		50		50		50		ns
t _{PHHEH}	RP# V _{HH} Setup to CE# Going High	2	100		100		100		ns
t _{VPEH}	V _{PP} Setup to CE# Going High	2	100		100		100		ns
t _{AVEH}	Address Setup to CE# Going High	3	40		40		40		ns
t _{DVEH}	Data Setup to CE# Going High	3	40		40		40		ns
t _{EHDX}	Data Hold from CE# High		5		5		5		ns
t _{EHAX}	Address Hold from CE# High		5		5		5		ns
t _{EHWH}	WE# Hold from CE# High		0		0		0		ns
t _{EHCL}	CE# Pulse Width High		25		25		25		ns
t _{EHRL}	CE# High to RY/BY# Going Low			90		90		90	ns
t _{EHGL}	Write Recovery before Read		0		0		0		ns
t _{QVVL}	V _{PP} Hold from Valid SRD, RY/BY# High	2, 4	0		0		0		ns
t _{QVPH}	RP# V _{HH} Hold from Valid SRD, RY/BY# High	2, 4	0		0		0		ns

NOTES :

- In systems where CE# defines the write pulse width (within a longer WE# timing waveform), all setup, hold, and inactive WE# times should be measured relative to the CE# waveform.
- Sampled, not 100% tested.
- Refer to **Table 3** for valid A_{IN} and D_{IN} for block erase, word write, or lock-bit configuration.
- V_{PP} should be held at V_{PPH1/2/3} (and if necessary RP# should be held at V_{HH}) until determination of block erase, word write, or lock-bit configuration success (SR.1/3/4/5 = 0).
- See **Fig. 10 "Transient Input/Output Reference Waveform"** and **Fig. 12 "Transient Equivalent Testing Load Circuit"** (High Speed Configuration) for testing characteristics.
- See **Fig. 11 "Transient Input/Output Reference Waveform"** and **Fig. 12 "Transient Equivalent Testing Load Circuit"** (Standard Configuration) for testing characteristics.

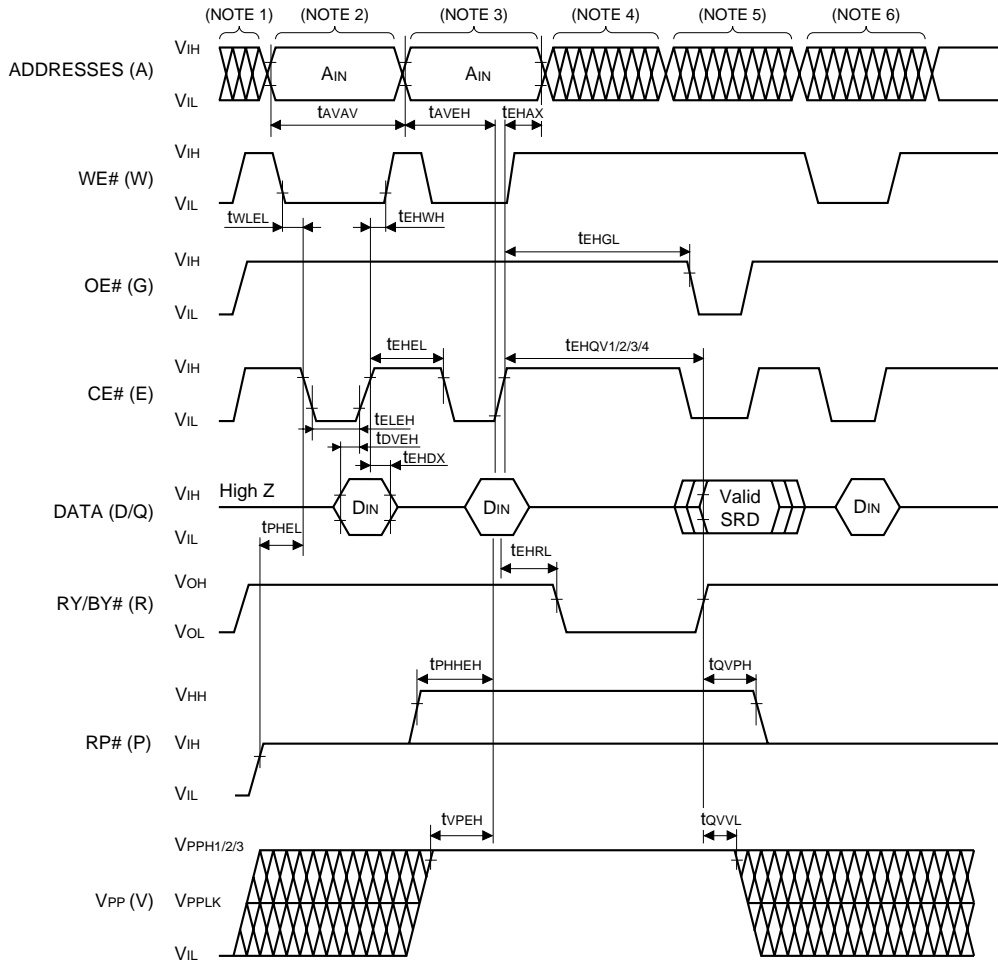

NOTES :

1. Vcc power-up and standby.
2. Write block erase or word write setup.
3. Write block erase confirm or valid address and data.
4. Automated erase or program delay.
5. Read status register data.
6. Write Read Array command.

Fig. 15 AC Waveform for CE#-Controlled Write Operations

6.2.7 RESET OPERATIONS

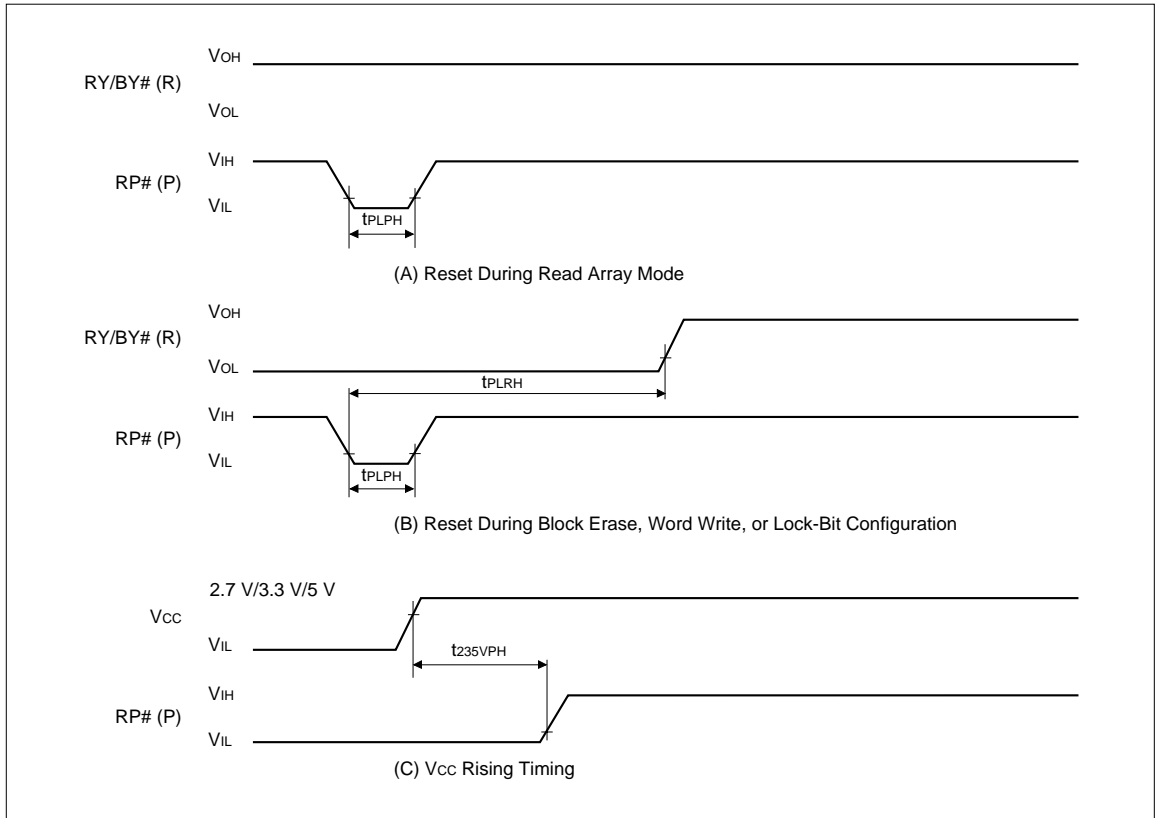

Fig. 16 AC Waveform for Reset Operation

Reset AC Specifications (NOTE 1)

SYMBOL	PARAMETER	NOTE	V _{CC} = 2.7 to 3.6 V		V _{CC} = 5.0±0.5 V		UNIT
			MIN.	MAX.	MIN.	MAX.	
t _{PLPH}	RP# Pulse Low Time (If RP# is tied to V _{CC} , this specification is not applicable)		100		100		ns
t _{PLRH}	RP# Low to Reset during Block Erase, Word Write, or Lock-Bit Configuration	2, 3		20 28 (2.7 V V _{CC})		12	µs
t _{235VPH}	V _{CC} 2.7 V to RP# High V _{CC} 3.0 V to RP# High V _{CC} 4.5 V to RP# High	4	100		100		ns

NOTES :

1. These specifications are valid for all product versions (packages and speeds).
2. If RP# is asserted while a block erase, word write, or lock-bit configuration operation is not executing, the reset will complete within 100 ns.
3. A reset time, t_{PHQV}, is required from the latter of RY/BY# or RP# going high until outputs are valid.
4. When the device power-up, holding RP#-low minimum 100 ns is required after V_{CC} has been in predefined range and also has been in stable there.

6.2.8 BLOCK ERASE, WORD WRITE AND LOCK-BIT CONFIGURATION PERFORMANCE (NOTE 3, 4)

• $V_{CC} = 2.7$ to 3.0 V, $T_A = 0$ to $+70^\circ\text{C}$

SYMBOL	PARAMETER	NOTE	$V_{PP} = 2.7$ to 3.0 V			$V_{PP} = 5.0 \pm 0.5$ V			$V_{PP} = 12.0 \pm 0.6$ V			UNIT
			MIN.	TYP.(NOTE 1)	MAX.	MIN.	TYP.(NOTE 1)	MAX.	MIN.	TYP.(NOTE 1)	MAX.	
t _{WHQV1} t _{EHQV1}	Word Write Time	2	49	63		20	28			15.4		μs
	Block Write Time	2	1.7	2.1		0.7	1.0			0.56		s
t _{WHQV2} t _{EHQV2}	Block Erase Time	2		3.0			2.0			1.9		s
t _{WHQV3} t _{EHQV3}	Set Lock-Bit Time	2		44			28			24.4		μs
t _{WHQV4} t _{EHQV4}	Clear Block Lock-Bits Time	2		3.8			2.6			2.3		s
t _{WHRH1} t _{EHHR1}	Word Write Suspend Latency Time to Read			12.6			10.5			10.5		μs
t _{WHRH2} t _{EHHR2}	Erase Suspend Latency Time to Read			34.1			20.2			20.2		μs

• $V_{CC} = 3.3 \pm 0.3$ V, $T_A = 0$ to $+70^\circ\text{C}$

SYMBOL	PARAMETER	NOTE	$V_{PP} = 3.3 \pm 0.3$ V			$V_{PP} = 5.0 \pm 0.5$ V			$V_{PP} = 12.0 \pm 0.6$ V			UNIT
			MIN.	TYP.(NOTE 1)	MAX.	MIN.	TYP.(NOTE 1)	MAX.	MIN.	TYP.(NOTE 1)	MAX.	
t _{WHQV1} t _{EHQV1}	Word Write Time	2	35	45		14	20			11		μs
	Block Write Time	2	1.2	1.5		0.5	0.7			0.4		s
t _{WHQV2} t _{EHQV2}	Block Erase Time	2		2.1			1.4			1.3		s
t _{WHQV3} t _{EHQV3}	Set Lock-Bit Time	2		31			20			17.4		μs
t _{WHQV4} t _{EHQV4}	Clear Block Lock-Bits Time	2		2.7			1.8			1.6		s
t _{WHRH1} t _{EHHR1}	Word Write Suspend Latency Time to Read			9			7.5			7.5		μs
t _{WHRH2} t _{EHHR2}	Erase Suspend Latency Time to Read			24.3			14.4			14.4		μs

NOTES :

- Typical values measured at $T_A = +25^\circ\text{C}$ and nominal voltages. Assumes corresponding lock-bits are not set. Subject to change based on device characterization.
- Excludes system-level overhead.
- These performance numbers are valid for all speed versions.
- Sampled, not 100% tested.

6.2.8 BLOCK ERASE, WORD WRITE AND LOCK-BIT CONFIGURATION PERFORMANCE (contd.) (NOTE 3, 4)

• $V_{CC} = 5.0 \pm 0.25 \text{ V}$, $5.0 \pm 0.5 \text{ V}$, $T_A = 0 \text{ to } +70^\circ\text{C}$

SYMBOL	PARAMETER	NOTE	$V_{PP} = 5.0 \pm 0.5 \text{ V}$			$V_{PP} = 12.0 \pm 0.6 \text{ V}$			UNIT
			MIN.	TYP. (NOTE 1)	MAX.	MIN.	TYP. (NOTE 1)	MAX.	
t _{WHQV1} t _{EHQV1}	Word Write Time	2	10	14			7.5		μs
	Block Write Time	2	0.4	0.5			0.25		s
t _{WHQV2} t _{EHQV2}	Block Erase Time	2		1.3			1.2		s
t _{WHQV3} t _{EHQV3}	Set Lock-Bit Time	2		18			15		μs
t _{WHQV4} t _{EHQV4}	Clear Block Lock-Bits Time	2		1.6			1.5		s
t _{WHRH1} t _{EHRH1}	Word Write Suspend Latency Time to Read			7.5			6		μs
t _{WHRH2} t _{EHRH2}	Erase Suspend Latency Time to Read			14.4			14.4		μs

NOTES :

1. Typical values measured at $T_A = +25^\circ\text{C}$ and nominal voltages. Assumes corresponding lock-bits are not set. Subject to change based on device characterization.
2. Excludes system-level overhead.
3. These performance numbers are valid for all speed versions.
4. Sampled, not 100% tested.

7 ORDERING INFORMATION

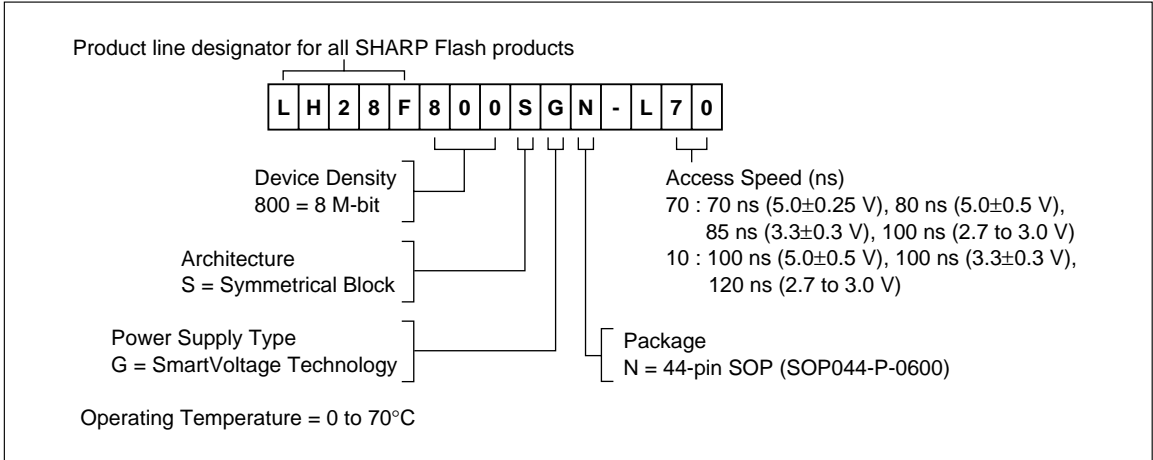

OPTION	ORDER CODE	VALID OPERATIONAL COMBINATIONS			
		V _{cc} = 2.7 to 3.0 V 50 pF load, 1.35 V I/O Levels	V _{cc} = 3.3±0.3 V 50 pF load, 1.5 V I/O Levels	V _{cc} = 5.0±0.5 V 100 pF load, TTL I/O Levels	V _{cc} = 5.0±0.25 V 30 pF load, 1.5 V I/O Levels
1	LH28F800SGN-L70	100 ns	85 ns	80 ns	70 ns
2	LH28F800SGN-L10	120 ns	100 ns	100 ns	

44 SOP (SOP044-P-0600)

