

Dot Matrix LED Unit for Indoor Use LT1465M(Lamp Type)

■ Features

- No. of dots : 16X16dots
- Outline dimensions : 64X64mm
- Dot size : ø3.0mm
- Dot pitch : 4.0mm
- Radiation color : Yellow-green+Red(High-luminosity)dichromatic type
- Driving method : 1/16 duty dynamic drive

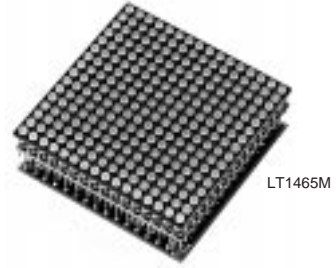

■ Absolute Maximum Ratings

(Ta=25°C)

Parameter	Symbol	Rating	Unit
Supply voltage for IC	VCC	-0.3 to +6.0	V
Supply voltage for LED	VLED	-0.3 to +5.5	V
Input voltage	VI	-0.3 to Vcc+0.3	V
Turn-on time	tON	1	ms
Operating temperature	ToPr	-20 to +45	°C
Storage temperature	Tstg	-20 to +85	°C
Power dissipation	P	13	W

■ Optical Characteristics

(VCC=5V, VLED=5V, Ta=25°C)

Parameter	Symbol	TYP.	Unit
Viewing angle	2θ1/2	110	°
Peak emission wavelength	Red	660	nm
	Yellow-green	565	

■ Luminance

Luminance is classified into 2 ranks shown below.

(VCC=5V, VLED=5V, Ta=25°C)

Radiation color	Rank		Unit
	1	2	
Red	240	300	cd/m ²
Yellow-green	240	300	

■ Terminal Functions

Connector	Symbol	Function
Power supply (CN1)	VLED	Supply voltage for LED (+5V)
	VCC	Supply voltage for IC (+5V)
	GND1	Ground for IC
	GND2	Ground for LED
Input signal (CN2)	A0 to A3	Address specification signal for row driver
	RDATA	Serial data input for red (H=ON, L=OFF) Shift from right to left(VD15→VD0) in the unit
	GDATA	Serial data input for yellow-green (H=ON, L=OFF) Shift from right to left(VD15→VD0) in the unit
	LATCH	Latch signal of display data. L: Contents of shift register are latched.
	ENABLE	Controls ON/OFF of LED (L: LED OFF)
	CLOCK	Clock signal for data transmission in the shift-register. (L→H: serial data is shifted.)
	GND1	Ground for signal. (Connected to ground for IC)
	A0 to A3	Buffered input signal
Output signal (CN3)	RDATA	Input signal generated through 16-bit shift register
	GDATA	Input signal generated through 16-bit shift register
	LATCH	Buffered input signal
	ENABLE	Buffered input signal
	CLOCK	Buffered input signal
	GND1	Ground for signal. (Connected to ground for IC)

Each signal is used as input signal for next unit.

* As for the terminal number, refer to the outline dimensions.

■ Electrical Characteristics

(VCC=5V, VLED=5V, Ta=25°C)

Parameter	Symbol	MIN.	TYP.	MAX.	Unit
Supply voltage for IC	VCC	4.75	5.0	5.25	V
Supply voltage for LED	VLED	4.5	5.0	5.25	V
IC current dissipation*1	ICC	—	20	40	mA
LED current dissipation*1	ILED	—	1.7	2.0	A
Input voltage	VIH	3.5	—	—	V
	VIL	—	—	1.5	V
Input current	IiH	—	—	0.1	μA
	IiL	—	—	0.12	mA
Clock frequency	fCLK	—	—	3.0	MHz
Frame frequency	fFR	80	100	625	Hz

*1 Under the condition that dichromatic all dots are lit.

■ Timing Chart

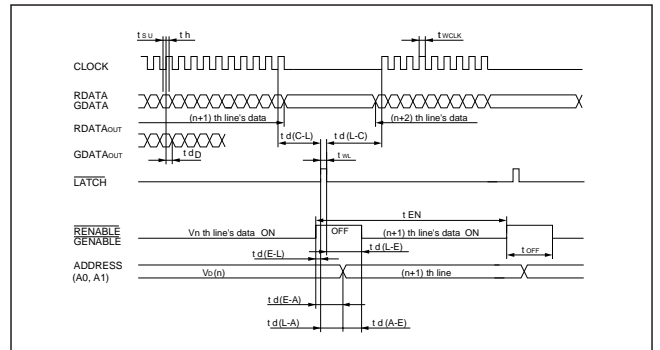

■ Block Diagram

