

SHINDENGEN

Super Fast Recovery Rectifiers

Single

DE5L60

600V 5A

FEATURES

SMT
High Voltage
trr50ns

APPLICATION

PFC
Switching power supply
Free Wheel
Home Appliances, Office Equipment,
Factory Automation

OUTLINE DIMENSIONS

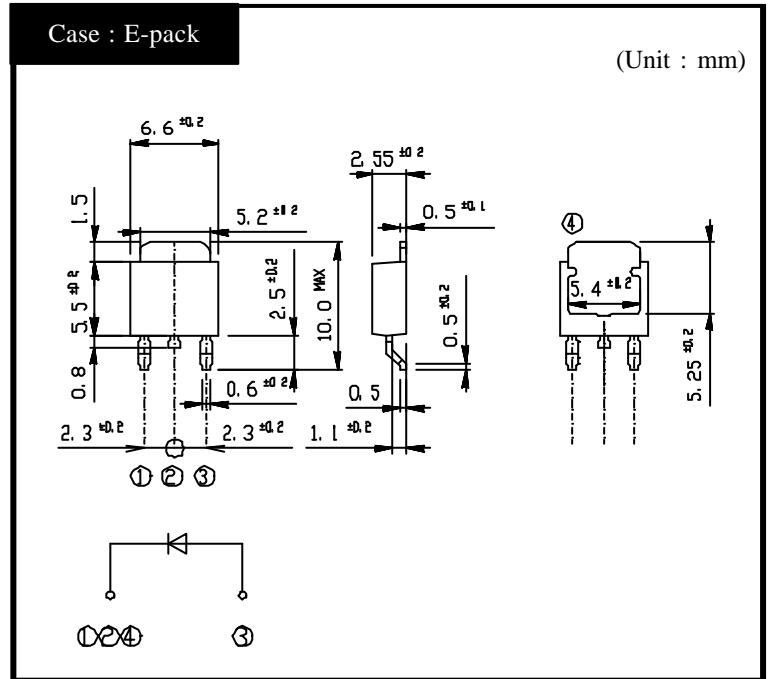

RATINGS

Absolute Maximum Ratings (If not specified Tc=25)

Item	Symbol	Conditions	Ratings	Unit
Storage Temperature	Tstg		-55 ~ 150	
Operating Junction Temperature	Tj		150	
Maximum Reverse Voltage	V _{RM}		600	V
Average Rectified Forward Current	I _O	50Hz sine wave, R-load, Tc=57	5	A
Peak Surge Forward Current	I _{FSM}	50Hz sine wave, Non-repetitive 1 cycle peak value, Tj=25	60	A

Electrical Characteristics (If not specified Tc=25)

Item	Symbol	Conditions	Ratings	Unit
Forward Voltage	V _F	I _F =5A, Pulse measurement	Max.2.00	V
Reverse Current	I _R	V _R =V _{RM} , Pulse measurement	Max.10	μA
Reverse Recovery Time	t _{rr}	I _F =0.5A, I _R =1A	Max.50	ns
Thermal Resistance	θ _{JC}	junction to case	Max.12	/W

DE5L60

Forward Voltage

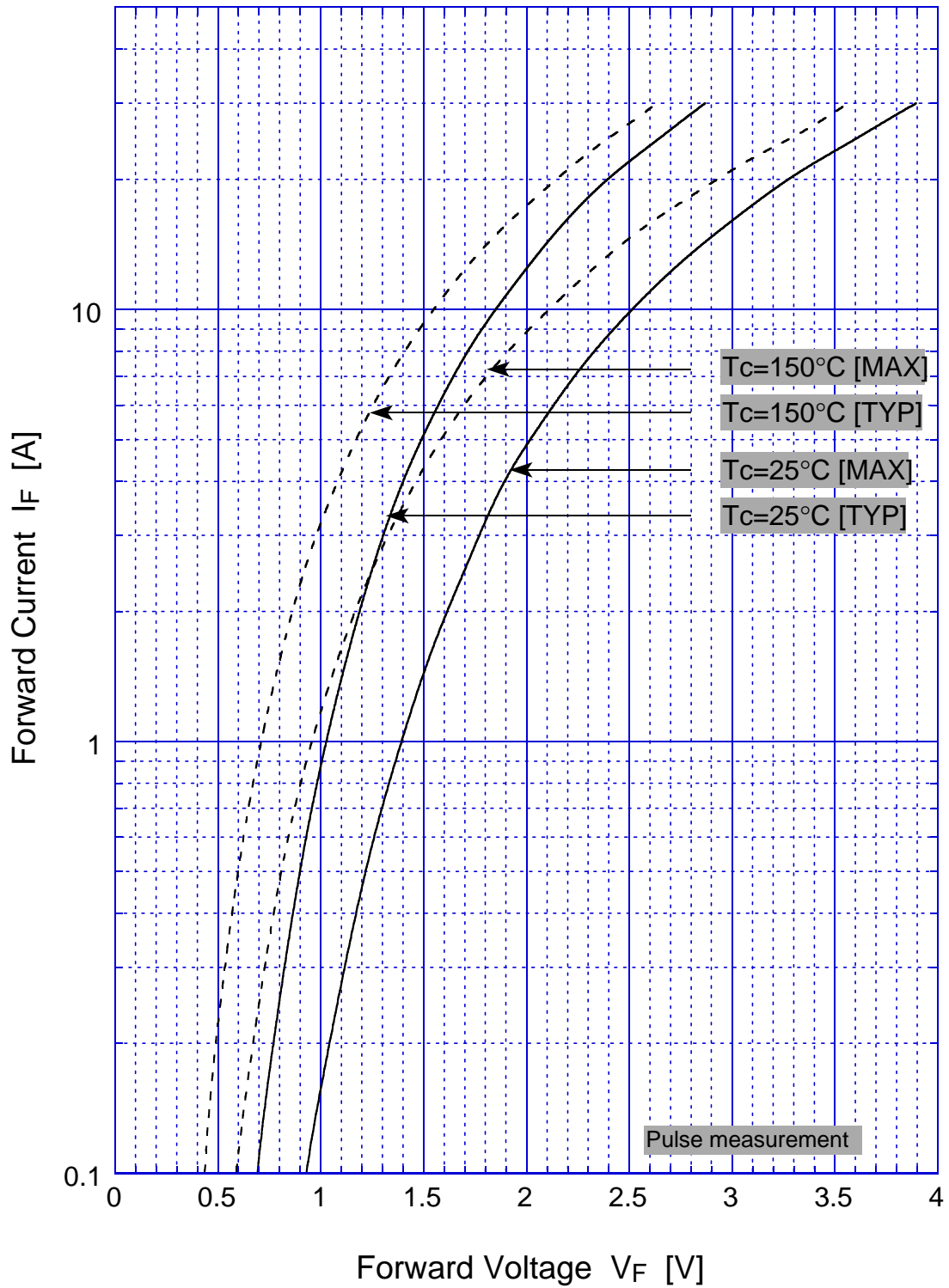

DE5L60

Forward Power Dissipation

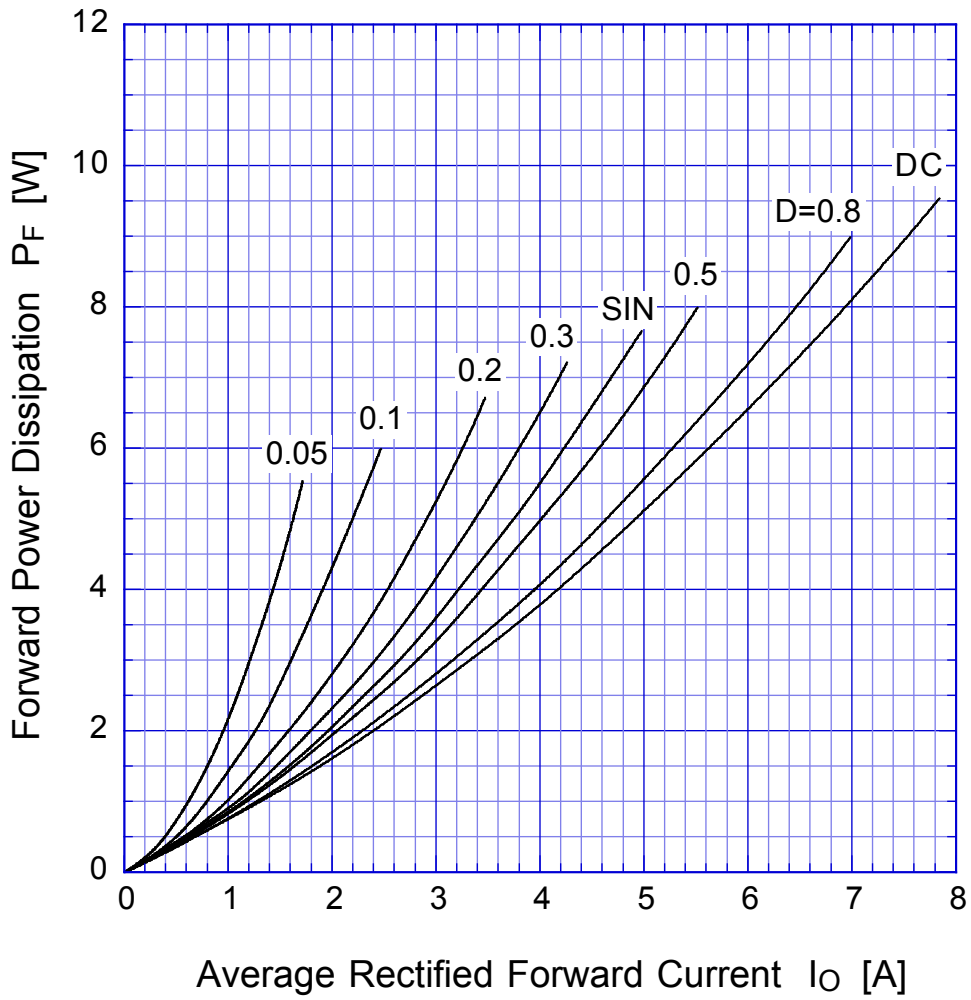

$T_j = 150^\circ\text{C}$

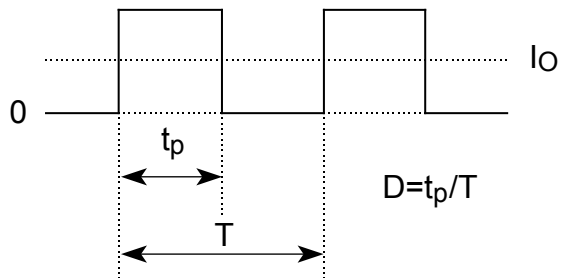

DE5L60

Peak Surge Forward Capability

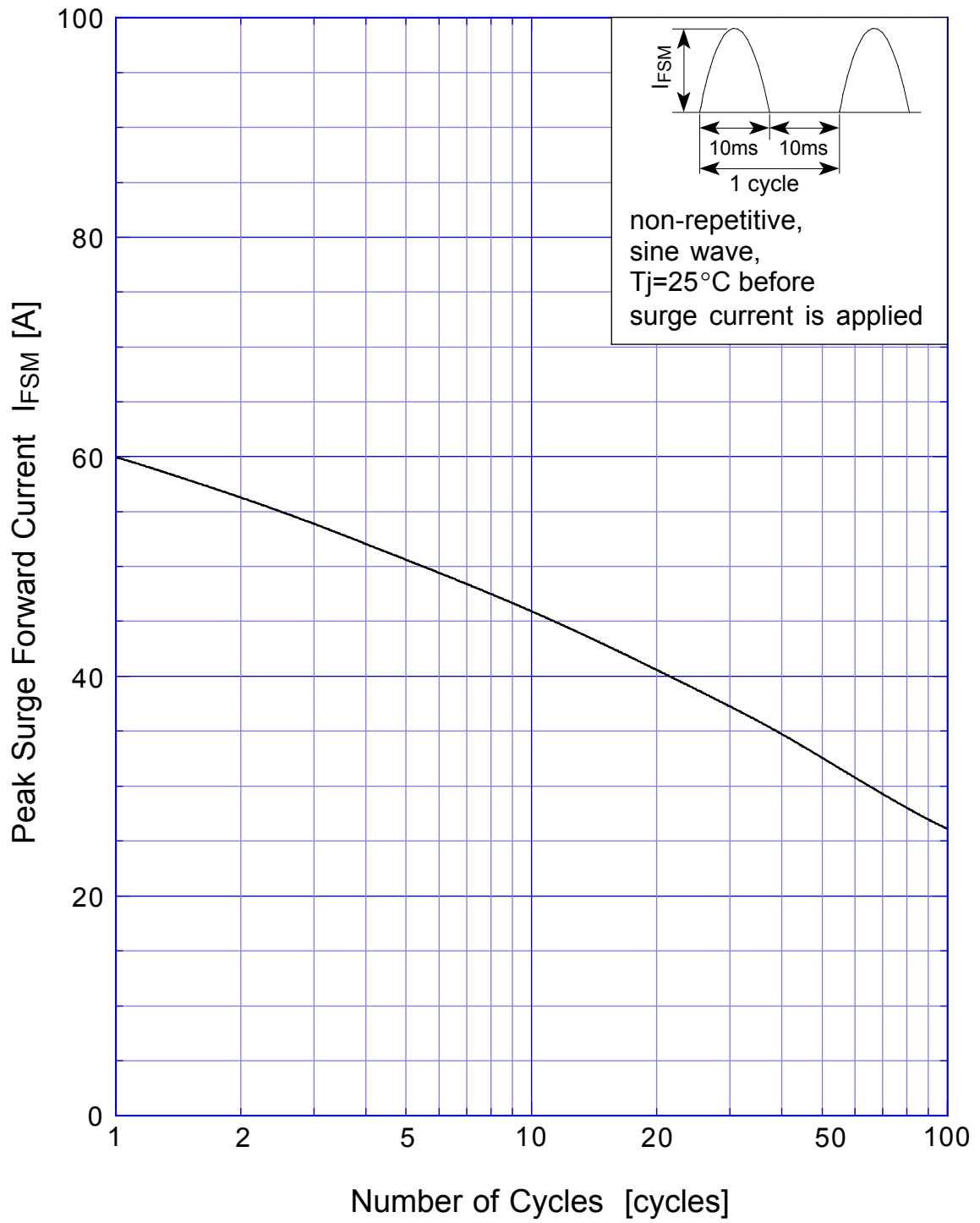

DE5L60

Derating Curve

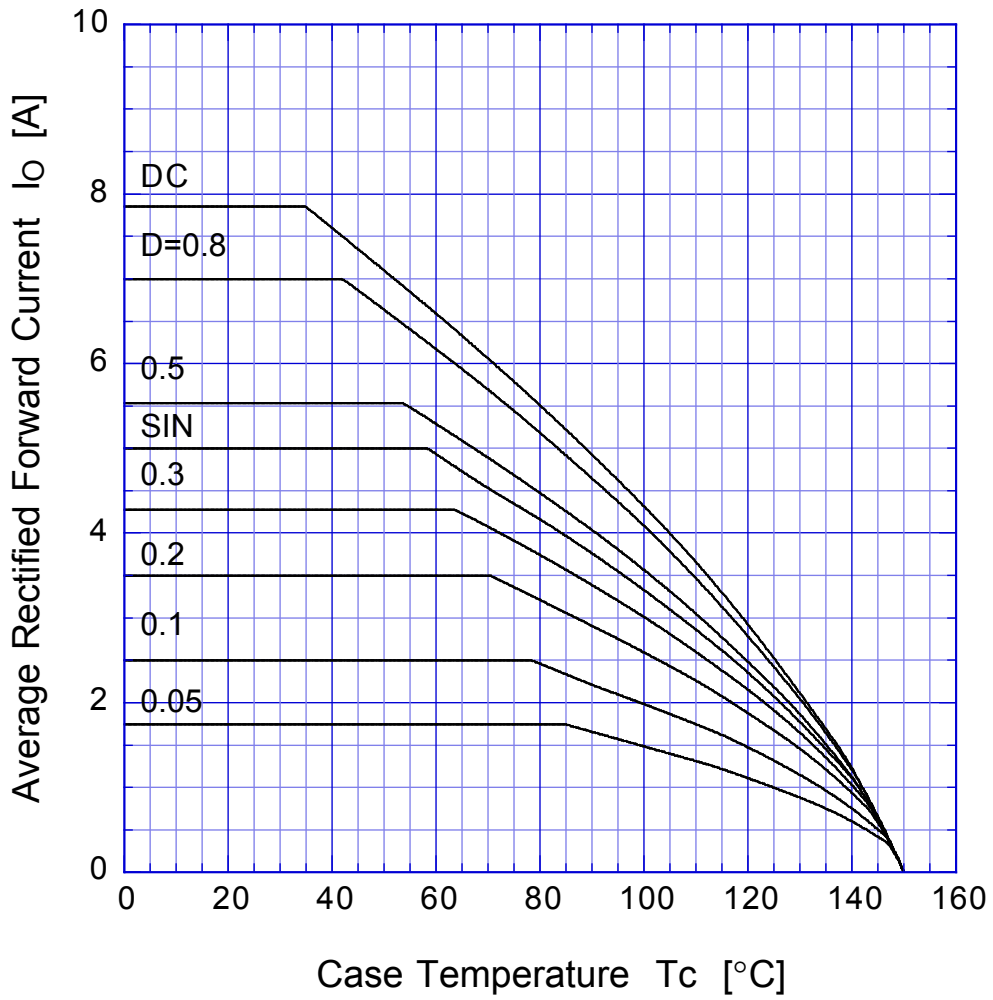

$V_R = 300V$

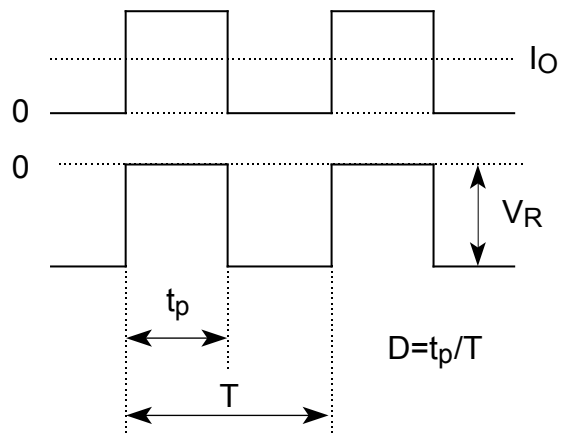

DE5L60 Junction Capacitance

