

S3WB20

200V 2.3A

OUTLINE DIMENSIONS

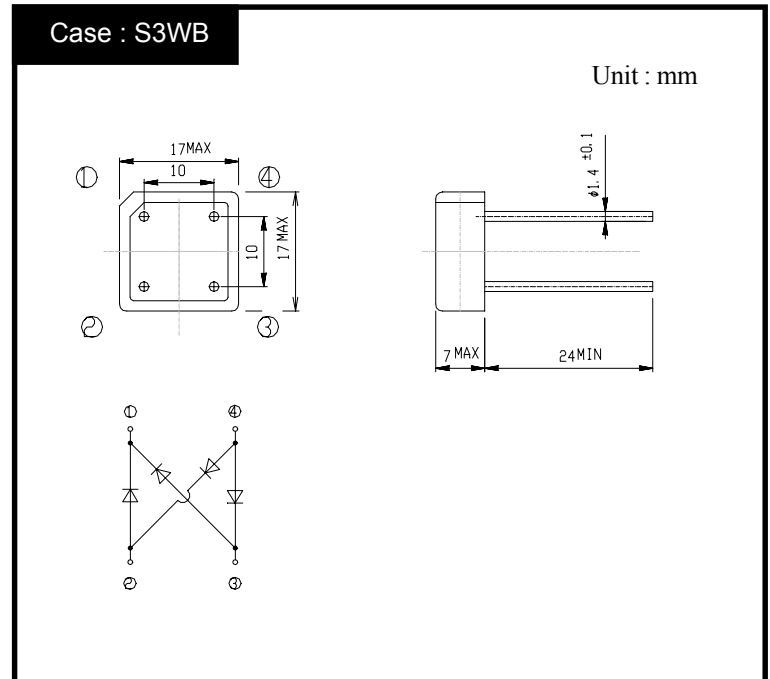

RATINGS

● Absolute Maximum Ratings

Item	Symbol	Conditions	Ratings	Unit
Storage Temperature	T_{stg}		-40~150	°C
Operating Junction Temperature	T_j		150	°C
Maximum Reverse Voltage	V_{RM}		200	V
Average Rectified Forward Current	I_O	50Hz sine wave, R-load, On glass-epoxy substrate, $T_a=40^\circ\text{C}$	2.3	A
Peak Surge Forward Current	I_{FSM}	50Hz sine wave, Non-repetitive 1cycle peak value, $T_j=25^\circ\text{C}$	120	A
Current Squared Time	I^2t	$1\text{ms} \leq t < 10\text{ms}$ $T_c=25^\circ\text{C}$	60	A^2s

● Electrical Characteristics ($T_l=25^\circ\text{C}$)

Item	Symbol	Conditions	Ratings	Unit
Forward Voltage	V_F	$I_F=2\text{A}$, Pulse measurement, Rating of per diode	Max.1.05	V
Reverse Current	I_R	$V_R=V_{RM}$, Pulse measurement, Rating of per diode	Max.10	μA
Thermal Resistance	θ_{jl}	junction to lead	Max.5.5	°C/W
	θ_{ja}	junction to ambient	Max.26.5	

S3WBx

Forward Voltage

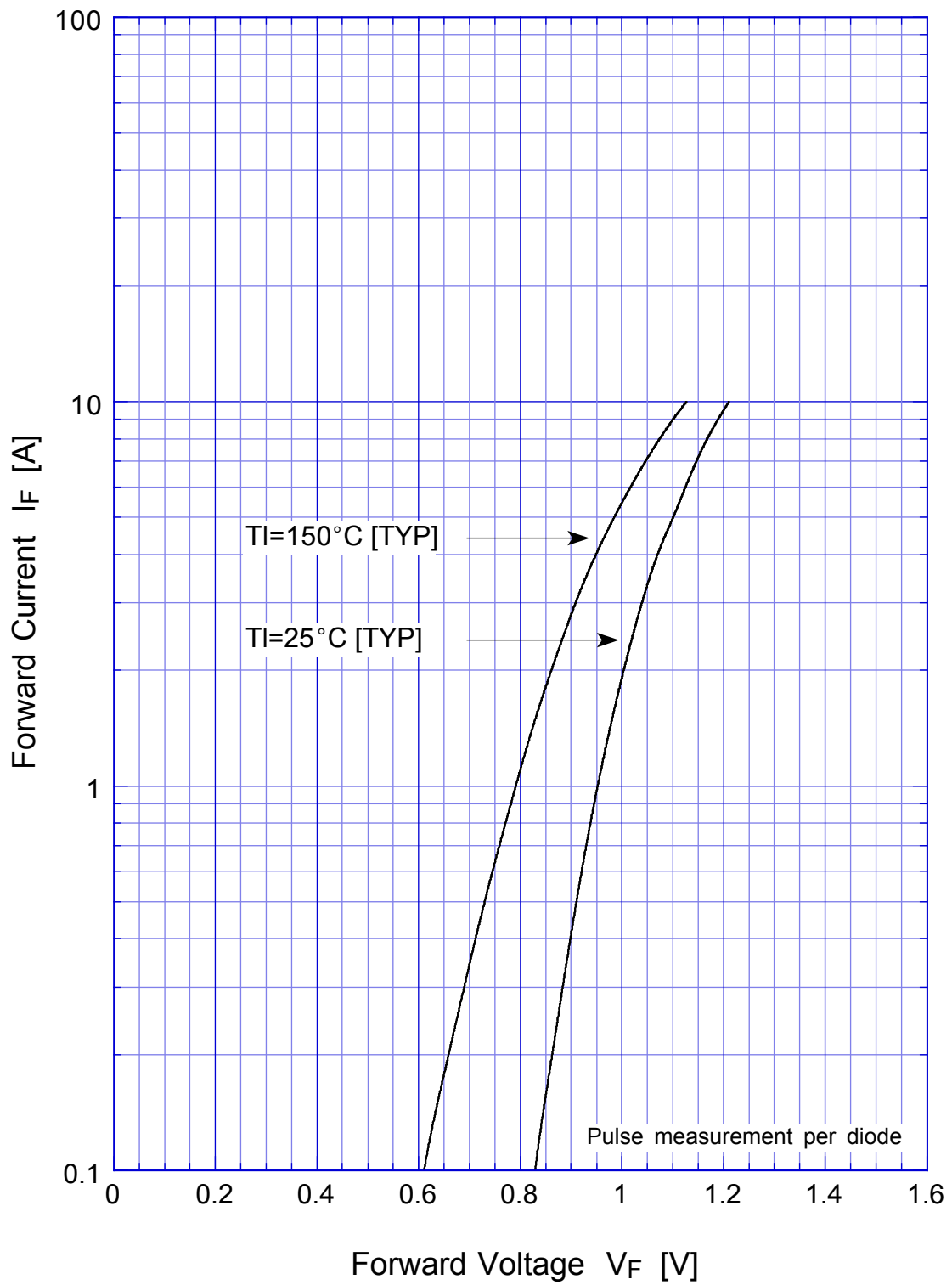

S3WBx

Forward Power Dissipation

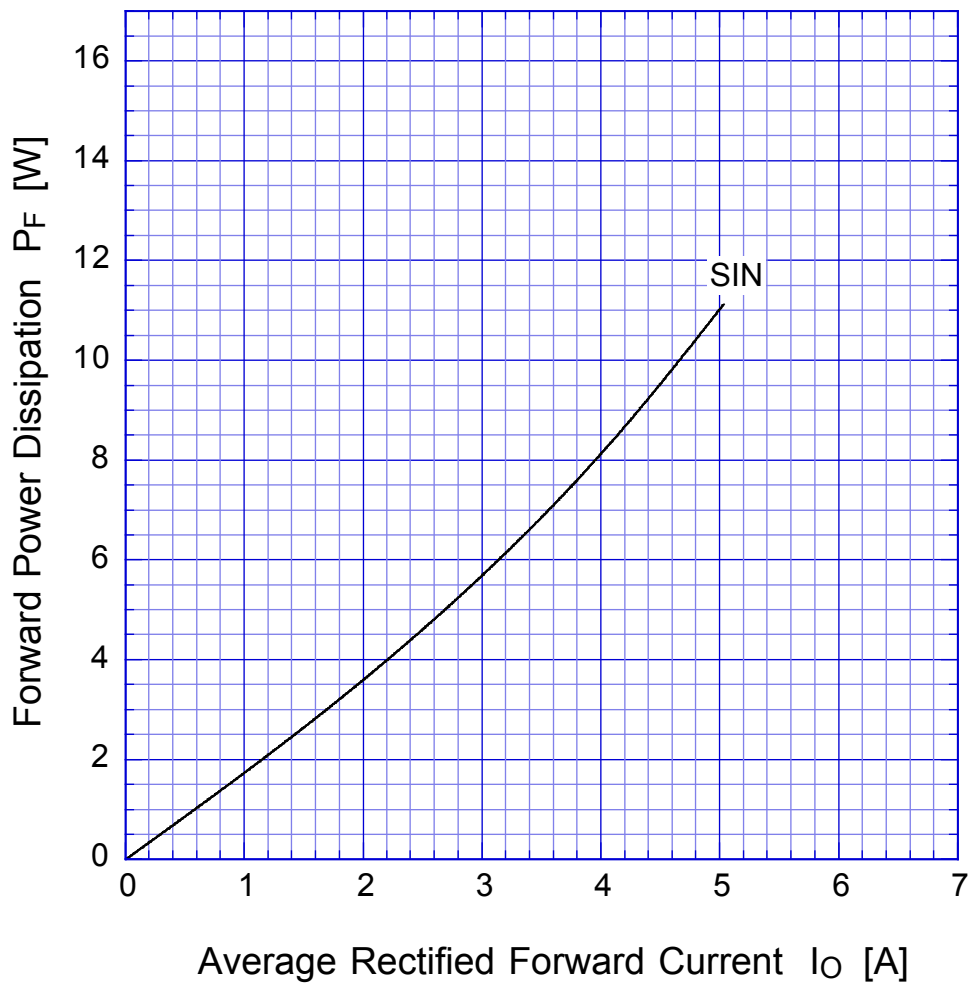

$T_j = 150^\circ\text{C}$
Sine wave

S3WBx

Derating Curve

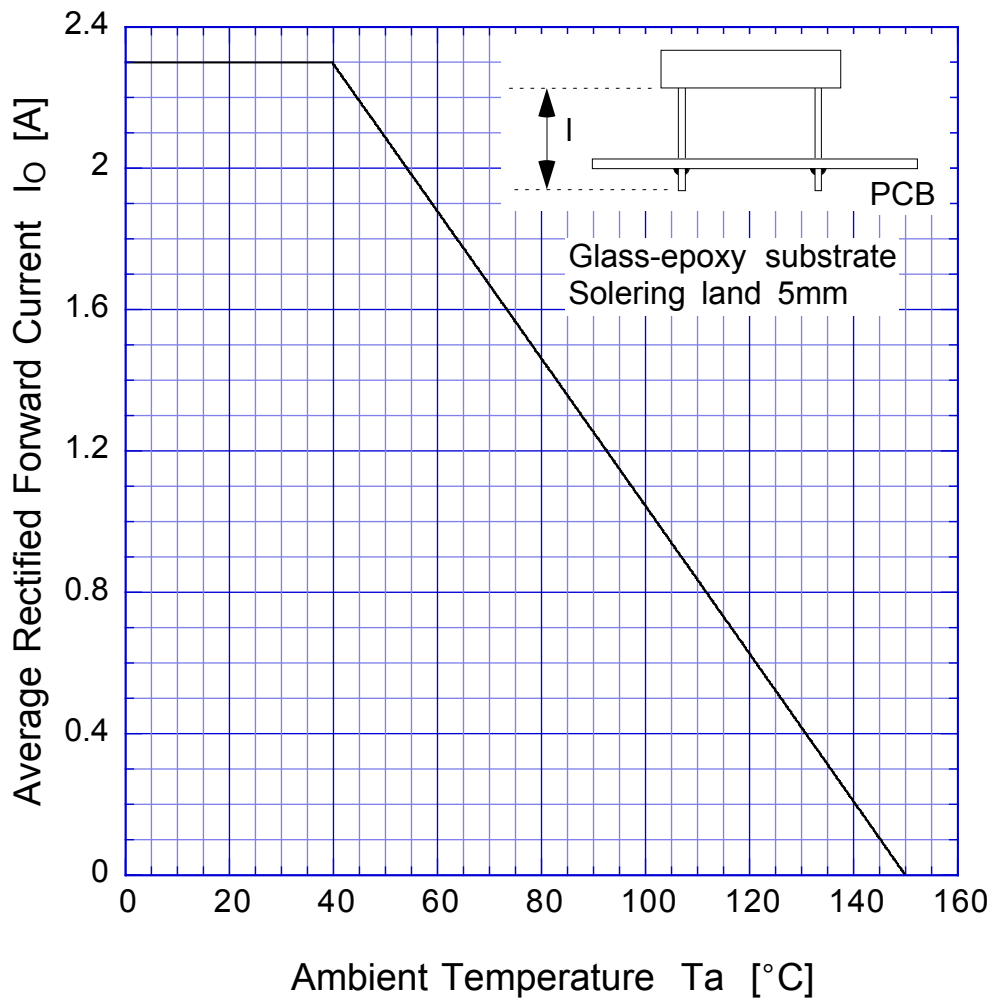

Sine wave
R-load
Free in air

S3WBx

Peak Surge Forward Capability

