

## Contents

Features .....	1
Applications .....	1
Dimensions (28-pin SOP).....	1
Pin Assignment .....	2
Terminal Functions .....	2
Block Diagram .....	3
Absolute Maximum Ratings.....	3
Recommended Operating Conditions.....	3
DC Characteristics.....	4
Instructions .....	6
Application Example (S-1343AF).....	6

The S-1343AF/13L43AF 4-bit microcomputer integrates 8-bit programmable timer, watch dog timer, carry output circuit, etc., on one chip. As it can be driven by batteries, this microcomputer is ideal for various compact portable equipment. In particular, S-13L43AF, which is a low-voltage operation version of S-1343AF, is designed to be driven by one battery (1.5 V).

■ Feature

- Si gate CMOS process
- Low power consumption
- Single power supply : 1.8 V min.(for S-1343AF, 500 KHz)  
1.2 V min.(for S-13L43AF, 500 KHz)
- High-speed operation : 500 KHz max.
- ROM: 1024×8 bits
- RAM: 32×4 bits
- 12 input lines and 8 output lines
- 2 timers: 8-bit programmable timer and delay timer
- Watch dog timer
- Interrupt function
- Standby function (STOP, HALT)
- Instruction execution time: 8 μ SEC /Inst min. (at 500 KHz)
- Instructions: 79 types (114 including addressing modes)  
10-level subroutine nesting
- 28-pin SOP (terminal distance: 1.27 mm)

■ Applications

- Infrared remote controller
- Compact portable equipment, others

■ Dimensions (28-pin SOP)

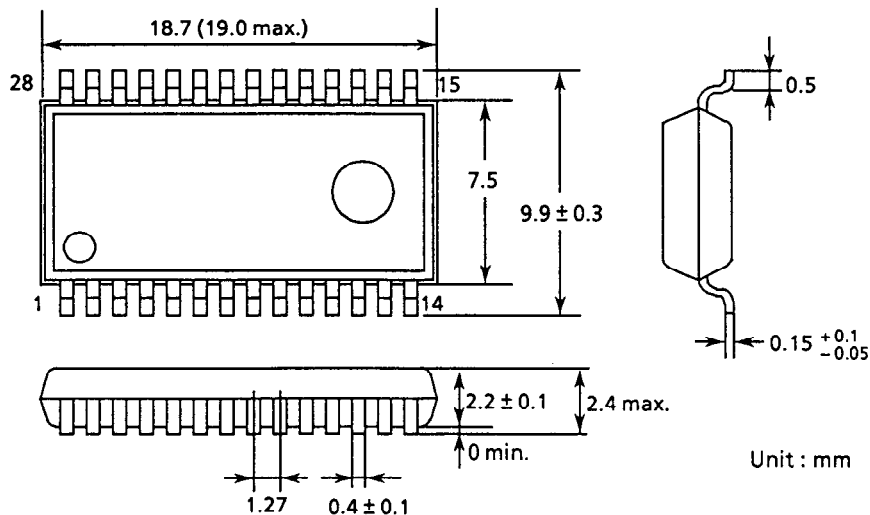

Figure 1

■ Pin Assignments

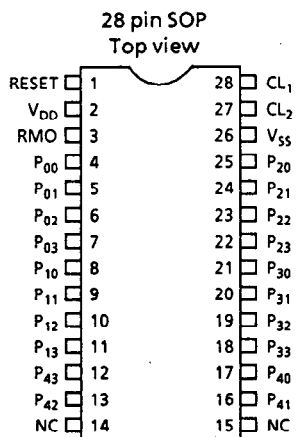

Figure 2

■ Terminal Functions

Table 1

Name	I/O	Functions
V <sub>DD</sub>	—	Positive power terminal
V <sub>SS</sub>	—	GND potential terminal
RESET	Input	Reset input terminal (Schmitt trigger input) Active level can be selected with mask option • Active low: with pull-up resistor • Active high: with pull-down resistor
CL <sub>1</sub> CL <sub>2</sub>	I/O	Ceramic oscillator connection terminal
RMO	Output	Carrier output terminal
P <sub>00</sub> to P <sub>03</sub>	Output	Output port (Nch open drain output and CMOS output can be selected with mask option)
P <sub>10</sub> to P <sub>13</sub>	Output	Output port (Nch open drain output and CMOS output can be selected with mask option)
P <sub>20</sub> to P <sub>23</sub>	Input	Input port (pull-up resistor can be built in with mask option)
P <sub>30</sub> to P <sub>33</sub>	Input	Input port (pull-up resistor can be built in with mask option)
P <sub>40</sub> to P <sub>43</sub>	Input	Input port (pull-up resistor can be built in with mask option)

■ Block Diagram

S-1343/L43AF is connected by 4-bit data bus (DB), 12-bit address bus (AB), control signals, etc., and controls the memories (ROM, RAM), registers, I/O ports, logic circuits (ALU), timers, etc.

One machine cycle (a cycle) consists of four system clocks.

Instruction cycles vary from one to six cycles, depending on the type of instruction.

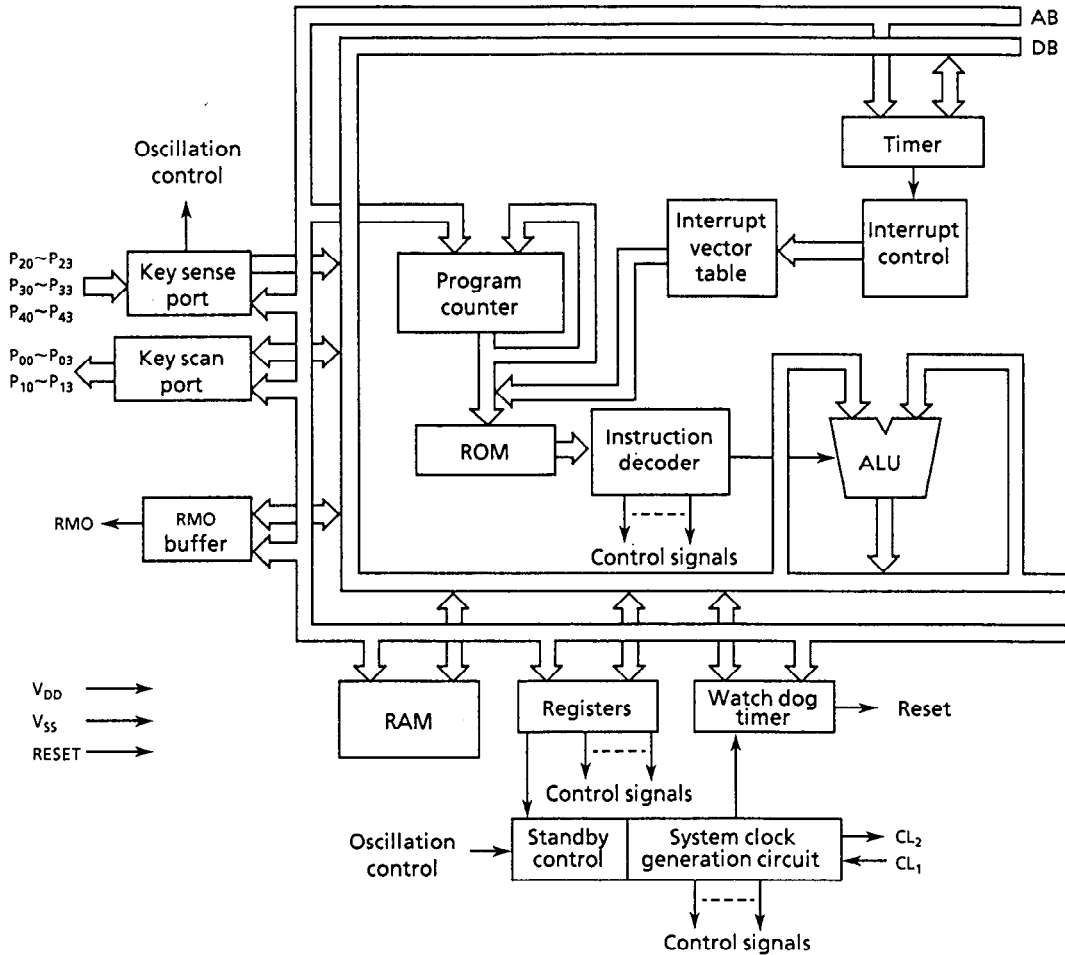

Figure 3

■ Absolute Maximum Ratings

Table 2

Item	Symbol	Conditions	Rating	Unit
Storage temperature	$T_{stg}$		-40 to +125	°C
Operating temperature	$T_{opr}$		-10 to +70	°C
Power supply voltage	$V_{DD}$	$T_a = 25^\circ\text{C}$	S-1343AF : -0.3 to +7.0	V
			S-13L43AF : -0.3 to +4.0	V
Input voltage	$V_{IN}$	$T_a = 25^\circ\text{C}$	$V_{SS} - 0.3$ to $V_{DD} + 0.3$	V
Output voltage	$V_{OUT}$	$T_a = 25^\circ\text{C}$	$V_{SS}$ to $V_{DD}$	V
Power dissipation	$P_d$	$T_a = 25^\circ\text{C}$	300	mW

■ Recommended Operating Conditions

Table 3

( $T_a = -10^\circ\text{C}$  to  $+70^\circ\text{C}$ )

Item	Symbol	Conditions	Min.	Typ.	Max.	Unit
Power supply voltage	$V_{DD}$	System clock: 500 kHz for S-1343AF	1.8	—	6.0	V
		System clock: 500 kHz for S-13L43AF	1.2	—	3.6	V
Input voltage	$V_{IN}$		0	—	$V_{DD}$	V
System clock frequency	$f_{sys}$	$V_{DD} = 1.8$ to $6.0$ V (S-1343AF) $V_{DD} = 1.2$ to $3.6$ V (S-13L43AF)	200	—	500	KHz

**CMOS 4-bit 1-chip MICROCOMPUTER**  
**S-1343AF/13L43AF**

■ DC Characteristics

1. S-1343AF ( $V_{DD} = 3\text{ V}$ )

Table 4

( $T_a = -10^\circ\text{C}$  to  $+70^\circ\text{C}$ ,  $V_{DD} = 3.0\text{ V}$ )

Item	Symbol	Conditions	Min.	Typ.	Max.	Unit
Operating current consumption	$I_{CCO}$	System clock : 455 KHz	—	0.12	0.25	mA
Standby current consumption	$I_{CCS}$	At STOP mode	—	0.4	1	$\mu\text{A}$
High level input voltage	$V_{IH}$		$0.8 \times V_{DD}$	—	—	V
Low level input voltage	$V_{IL}$		—	—	$0.2 \times V_{DD}$	V
High level input leakage current	$I_{IH}$	All input terminals $V_{IN} = V_{DD}$	—	—	1	$\mu\text{A}$
Low level input leakage current	$I_{IL}$	Without pull-up resistor, $V_{IN} = V_{SS}$	-1	—	—	$\mu\text{A}$
High level input current	$I_{IH}$	RESET terminal: When active high $V_{IN} = V_{DD}$	0.6	2	6	$\mu\text{A}$
		RESET terminal: When active low $V_{IN} = V_{DD} - 0.3\text{ V}$	-9	—	-0.9	$\mu\text{A}$
Low level input current 1	$I_{IL1}$	With pull-up resistor, $V_{IN} = V_{SS}$	-90	-30	-10	$\mu\text{A}$
Low level input current 2	$I_{IL2}$	RESET terminal: When active high $V_{IN} = V_{SS} + 0.3\text{ V}$	0.9	—	9	$\mu\text{A}$
		RESET terminal: When active low $V_{IN} = V_{SS}$	-6	-2	-0.6	$\mu\text{A}$
High level output current 1	$I_{OH1}$	RMO terminal, $V_{OUT} = 2.1\text{ V}$	—	—	-5.0	mA
High level output current 2	$I_{OH2}$	Output port, $V_{OUT} = 2.6\text{ V}$	—	—	-100	$\mu\text{A}$
Low level output current 1	$I_{OL1}$	RMO terminal, $V_{OUT} = 0.4\text{ V}$	250	—	—	$\mu\text{A}$
Low level output current 2	$I_{OL2}$	Output port, $V_{OUT} = 0.4\text{ V}$	1.0	—	—	mA
Schmitt hysteresis width	$V_{WD}$		—	0.7	—	V

2. S-1343AF ( $V_{DD} = 5\text{ V}$ )

Table 5

( $T_a = -10^\circ\text{C}$  to  $+70^\circ\text{C}$ ,  $V_{DD} = 5.0\text{ V}$ )

Item	Symbol	Conditions	Min.	Typ.	Max.	Unit
Operating current consumption	$I_{CCO}$	System clock : 455 KHz	—	0.4	0.7	mA
Standby current consumption	$I_{CCS}$	At STOP mode	—	0.5	5	$\mu\text{A}$
High level input voltage	$V_{IH}$		$0.8 \times V_{DD}$	—	—	V
Low level input voltage	$V_{IL}$		—	—	$0.2 \times V_{DD}$	V
High level input leakage current	$I_{IH}$	All input terminals $V_{IN} = V_{DD}$	—	—	1	$\mu\text{A}$
Low level input leakage current	$I_{IL}$	Without pull-up resistor, $V_{IN} = V_{SS}$	-1	—	—	$\mu\text{A}$
High level input current	$I_{IH}$	RESET terminal: When active high $V_{IN} = V_{DD}$	2	7	20	$\mu\text{A}$
		RESET terminal: When active low $V_{IN} = V_{DD} - 0.3\text{ V}$	-13.5	—	-1.5	$\mu\text{A}$
Low level input current 1	$I_{IL1}$	With pull-up resistor, $V_{IN} = V_{SS}$	-270	-90	-30	$\mu\text{A}$
Low level input current 2	$I_{IL2}$	RESET terminal: When active high $V_{IN} = V_{SS} + 0.3\text{ V}$	1.5	—	15	$\mu\text{A}$
		RESET terminal: When active low $V_{IN} = V_{SS}$	-20	-6.5	-2	$\mu\text{A}$
High level output current 1	$I_{OH1}$	RMO terminal, $V_{OUT} = 4.1\text{ V}$	—	—	-8.0	mA
High level output current 2	$I_{OH2}$	Output port, $V_{OUT} = 4.6\text{ V}$	—	—	-250	$\mu\text{A}$
Low level output current 1	$I_{OL1}$	RMO terminal, $V_{OUT} = 0.4\text{ V}$	500	—	—	$\mu\text{A}$
Low level output current 2	$I_{OL2}$	Output port, $V_{OUT} = 0.4\text{ V}$	2.0	—	—	mA
Schmitt hysteresis width	$V_{WD}$		—	1.6	—	V

3. S-13L43AF ( $V_{DD} = 1.5V$ )

Table 6

( $T_a = -10^\circ C$  to  $+70^\circ C$ ,  $V_{DD} = 1.5V$ )

Item	Symbol	Conditions	Min.	Typ.	Max.	Unit
Operating current consumption	$I_{CCO}$	System clock : 455 KHz	—	0.05	0.1	mA
Standby current consumption	$I_{CCS}$	At STOP mode	—	0.5	10.0	$\mu A$
High level input voltage	$V_{IH}$		$0.8 \times V_{DD}$	—	—	V
Low level input voltage	$V_{IL}$		—	—	$0.2 \times V_{DD}$	V
High level input leakage current	$I_{IH}$	All input terminals $V_{IN} = V_{DD}$	—	—	1	$\mu A$
Low level input leakage current	$I_{IL}$	Without pull-up resistor, $V_{IN} = V_{SS}$	-1	—	—	$\mu A$
High level input current	$I_{IH}$	RESET terminal: When active high $V_{IN} = V_{DD}$	0.6	2	6	$\mu A$
		RESET terminal: When active low $V_{IN} = V_{DD} - 0.3V$	-9	—	-0.9	$\mu A$
Low level input current 1	$I_{IL1}$	With pull-up resistor, $V_{IN} = V_{SS}$	-90	-30	-10	$\mu A$
Low level input current 2	$I_{IL2}$	RESET terminal: When active high $V_{IN} = V_{SS} + 0.3V$	0.9	—	9	$\mu A$
		RESET terminal: When active low $V_{IN} = V_{SS}$	-6	-2	-0.6	$\mu A$
High level output current 2	$I_{OH2}$	Output port, $V_{OUT} = 1.1V$	—	—	-100	$\mu A$
Low level output current 1	$I_{OL1}$	RMO terminal, $V_{OUT} = 0.4V$	200	—	—	$\mu A$
Low level output current 2	$I_{OL2}$	Output port, $V_{OUT} = 0.4V$	1.0	—	—	mA
Schmitt hysteresis width	$V_{WD}$		—	0.2	—	V

4. S-13L43AF ( $V_{DD} = 3V$ )

Table 7

( $T_a = -10^\circ C$  to  $+70^\circ C$ ,  $V_{DD} = 3.0V$ )

Item	Symbol	Conditions	Min.	Typ.	Max.	Unit
Operating current consumption	$I_{CCO}$	System clock : 455 KHz	—	0.2	0.4	mA
Standby current consumption	$I_{CCS}$	At STOP mode	—	0.5	10.0	$\mu A$
High level input voltage	$V_{IH}$		$0.8 \times V_{DD}$	—	—	V
Low level input voltage	$V_{IL}$		—	—	$0.2 \times V_{DD}$	V
High level input leakage current	$I_{IH}$	All input terminals $V_{IN} = V_{DD}$	—	—	1	$\mu A$
Low level input leakage current	$I_{IL}$	Without pull-up resistor, $V_{IN} = V_{SS}$	-1	—	—	$\mu A$
High level input current	$I_{IH}$	RESET terminal: When active high $V_{IN} = V_{DD}$	4	12	36	$\mu A$
		RESET terminal: When active low $V_{IN} = V_{DD} - 0.3V$	-20	—	-2.5	$\mu A$
Low level input current 1	$I_{IL1}$	With pull-up resistor, $V_{IN} = V_{SS}$	-500	-170	-60	$\mu A$
Low level input current 2	$I_{IL2}$	RESET terminal: When active high $V_{IN} = V_{SS} + 0.3V$	2.5	—	20	$\mu A$
		RESET terminal: When active low $V_{IN} = V_{SS}$	-35	-12.5	-4	$\mu A$
High level output current 1	$I_{OH1}$	RMO terminal, $V_{OUT} = 2.6V$	—	—	-4.0	mA
High level output current 2	$I_{OH2}$	Output port, $V_{OUT} = 2.6V$	—	—	-250	$\mu A$
Low level output current 1	$I_{OL1}$	RMO terminal, $V_{OUT} = 0.4V$	400	—	—	$\mu A$
Low level output current 2	$I_{OL2}$	Output port, $V_{OUT} = 0.4V$	2.0	—	—	mA
Schmitt hysteresis width	$V_{WD}$		—	0.7	—	V

■ **Instructions**

1. 1-byte and 2-byte instructions
  - Byte 1 is called "op code", which indicates kinds of instruction.
  - Byte 2 is called "operand", which indicates objects of instruction.
2. Ten types of addressing modes
  - 1) Absolute addressing mode: ABS
  - 2) Relative addressing mode: REL
  - 3) Zero page addressing mode: (ZPG)
  - 4) Register indirect addressing mode: (X)
  - 5) Post-increment register indirect addressing mode: (X+)
  - 6) Pre-decrement register indirect addressing mode: (-X)
  - 7) Register addressing mode: REG
  - 8) 4-bit immediate addressing mode: IMM4
  - 9) 8-bit immediate addressing mode: IMM8
  - 10) Implied addressing mode: IMP
3. Number of instructions

**Table 8**

	Basic	Including addressing modes
Transfer instruction	13	27
Arithmetic operation instruction	34	47
Logical operation instruction	7	13
Branch instruction	21	21
Shift instruction	2	4
CPU control instruction	2	2
Total	79	114

■ **Application Example (S-1343AF)**

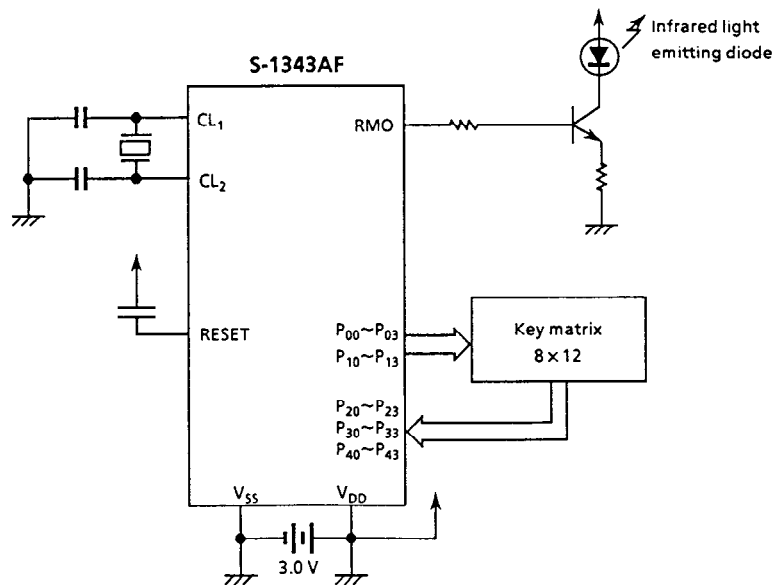

**Figure 4**