

Contents

Features 1
Applications 1
Dimensions (18-pin SOP, 20-pin SOP)..... 2
Pin Assignment 3
Terminal Functions 3
Block Diagram 4
Absolute Maximum Ratings..... 4
Recommended Operating Conditions..... 4
DC Characteristics..... 5
Instructions 6
Application Example..... 6

The S-13P48A 4-bit microcomputer integrates 8-bit programmable timer, watch dog timer, carry output circuit, etc., on one chip. As it can be driven by batteries, this microcomputer is ideal for various compact portable equipment.

■ **Feature**

- Si gate CMOS process
- Low power consumption
- Single power supply : 1.8 V min.(600 KHz)
- High-speed operation : 600 KHz max.
- EPROM: 512×8 bits
- RAM: 16×4 bits
- 5 input lines , 6 output lines and a remote control signal output line
- 2 timers: 8-bit programmable timer and delay timer
- Watch dog timer
- Interrupt function
- Standby function (STOP, HALT)
- Instruction execution time: 8 μ SEC /Inst min. (at 500 KHz)
- Instructions: 79 types (114 including addressing modes) 5-level subroutine nesting
- S-13P48AFE: 18-pin SOP (terminal distance:1.27mm)
- S-13P48AFS: 20-pin SSOP (terminal distance:0.65mm)

■ **Applications**

- Security system (Car, Home etc.)
- Toys
- Infrared remote controller
- Compact portable equipment, others

CMOS 4-bit 1-chip MICROCOMPUTER S-13P48A

■ Dimensions (18-pin SOP, 20-pin SSOP)

18-pin SOP

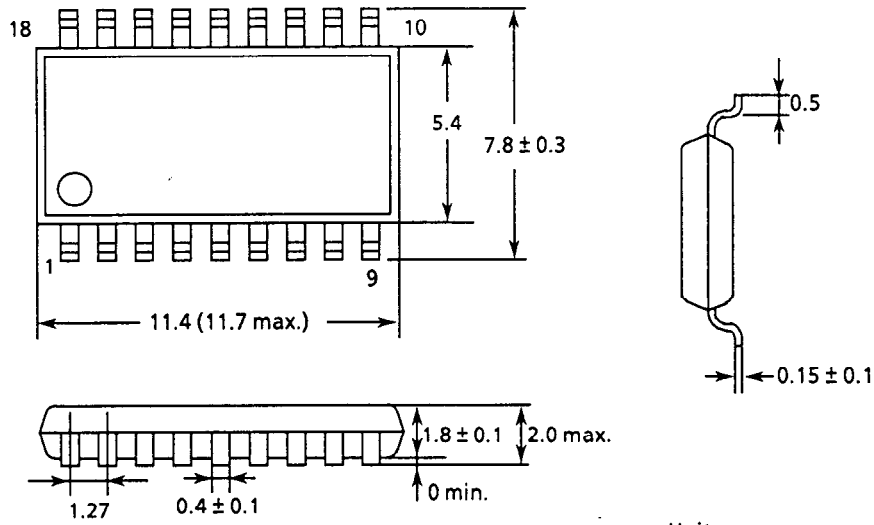

Unit : mm

20-pin SSOP

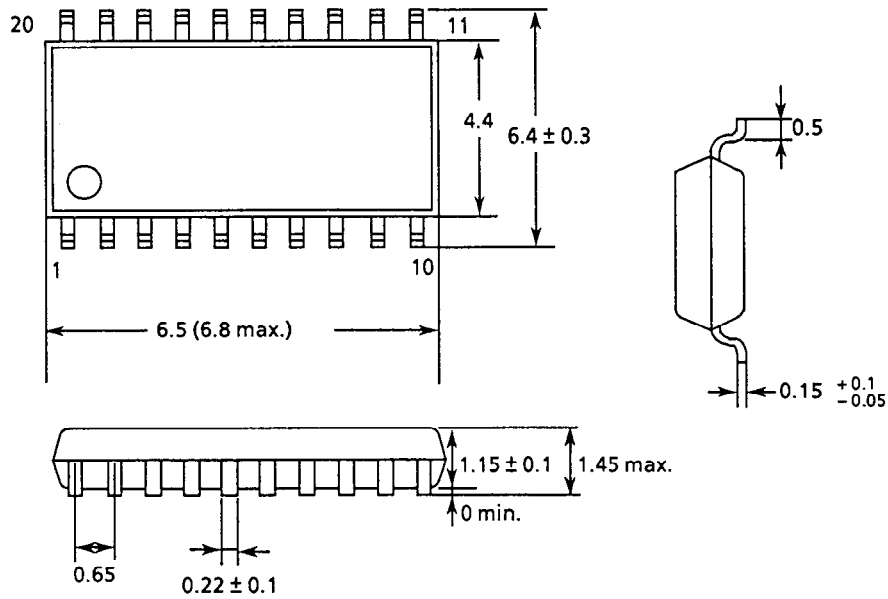

Unit : mm

Figure 1

■ Pin Assignments

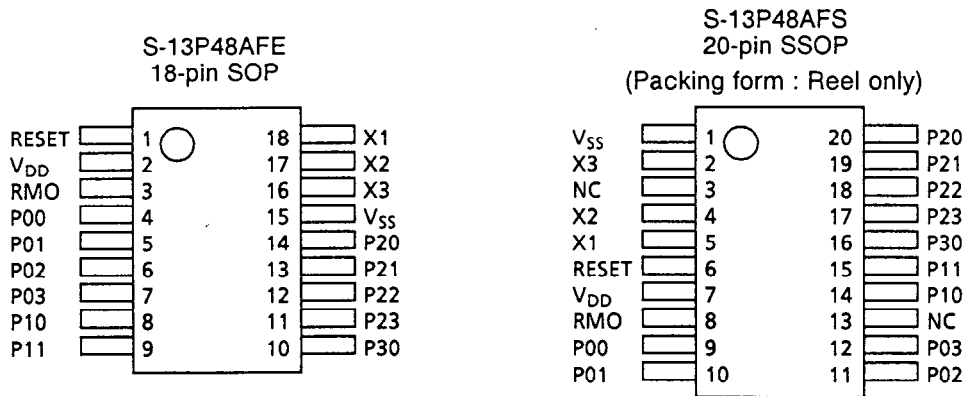

Figure 2

■ Terminal Functions

Table 1

Name	Normal operation		PROM programming mode	
	I/O	Function	I/O	Function
V _{DD}	—	Positive power supply	—	Positive power supply
V _{SS}	—	GND potential terminal	—	GND potential terminal
RESET	Input	Active high/reset input terminal (built-in Schmitt input, pull-down resistor)	Input	PROM write power supply (12.5 V) or V _{DD}
X1	Input	Condenser and register connect terminal for oscillation circuit	Input	Address clock input
X2	Output		Output	(OPEN)
X3	Output		Output	(OPEN)
RMO	Output	Carrier wave output	Input	Mode selection
P ₀₀	Output	Output port (Nch open drain output/CMOS output selection available through software)	Input/ Output	PROM data (D0)
P ₀₁				PROM data (D1)
P ₀₂				PROM data (D2)
P ₀₃				PROM data (D3)
P ₁₀	Output		Output	(OPEN)
P ₁₁				(OPEN)
P ₂₀	Input	Input port (Pullup resistance inclusion available through software)	Input	PROM data (D4)
P ₂₁				PROM data (D5)
P ₂₂				PROM data (D6)
P ₂₃				PROM data (D7)
P ₃₀	Input		Input/ Output	10 KΩ resistance pull-down

CMOS 4-bit 1-chip MICROCOMPUTER S-13P48A

Block Diagram

S-13P48A is connected by 4-bit data bus (DB), 12-bit address bus (AB), control signals, etc., and controls the memories (EPROM, RAM), registers, I/O ports, logic circuits (ALU), timers, etc.

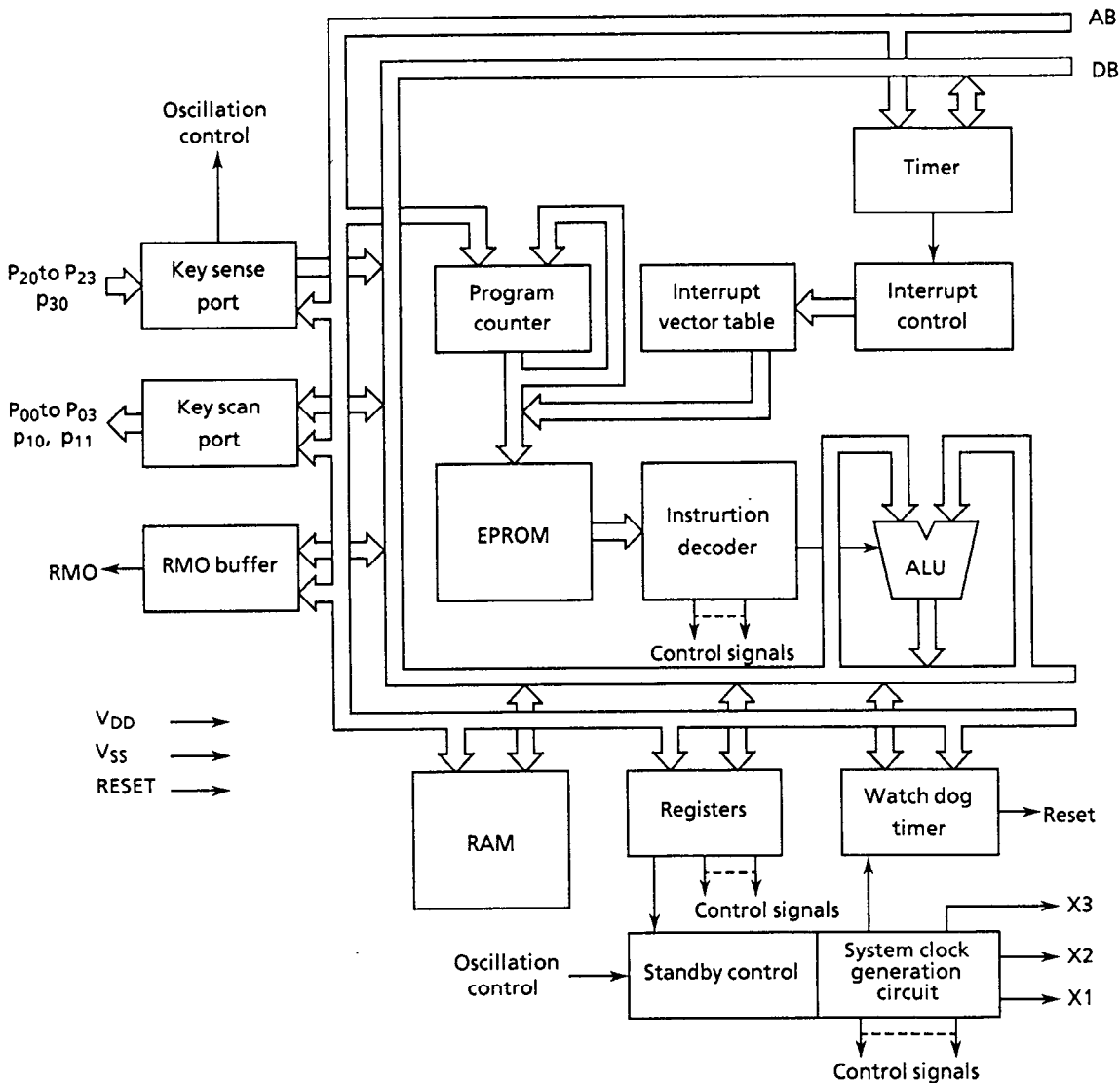

Figure 3

Absolute Maximum Ratings

Table 2

Item	Symbol	Conditions	Rating	Unit
Storage temperature	Tstg		-40 to +125	°C
Operating temperature	Topr		-20 to +70	°C
Power supply voltage	V _{DD}	T _a = 25°C	-0.3 to 7.0	V
Input voltage	V _{IN}	T _a = 25°C	V _{SS} -0.3 to V _{DD} + 0.3	V
Output voltage	V _{OUT}	T _a = 25°C	V _{SS} to V _{DD}	V
Power dissipation	P _d	T _a = 25°C	300	mW

Recommended Operating Conditions

Table 3

(T_a = -20 °C to +70 °C)

Item	Symbol	Conditions	Min.	Typ.	Max.	Unit
Power supply voltage	V _{DD}	System clock : 600 KHz	1.8		5.5	V
Input voltage	V _{IN}		0		V _{DD}	V
System clock frequency	f _{sys}	V _{DD} = 1.8 to 5.5V	200		600	KHz

■ DC Characteristics

Table 4 DC Characteristics (I)

(Ta = -20°C to +70°C, V_{DD} = 3.0 V)

Item	Symbol	Conditions	Min.	Typ.	Max.	Unit
Operating current consumption	I _{CCO}	System clock : 455 KHz	—	0.4	0.7	mA
Standby current consumption	I _{CCS}	At STOP mode	—	0.01	1	μA
High level input voltage	V _{IH}		0.8 × V _{DD}	—	—	V
Low level input voltage	V _{IL}		—	—	0.2 × V _{DD}	V
High level input leakage current	I _{IH}	All input terminals V _{IN} = V _{DD}	—	—	1	μA
Low level input leakage current	I _{IL}	Without pull-up resistor V _{IN} = V _{SS}	-1	—	—	μA
High level input current	I _{IH}	RESET terminal V _{IN} = V _{DD}	0.6	2	6	μA
Low level input current 1	I _{IL1}	With pull-up resistor V _{IN} = V _{SS}	-90	-30	-10	μA
Low level input current 2	I _{IL2}	RESET terminal V _{IN} = V _{SS} + 0.3 V	0.9	3	9	μA
High level output current 1	I _{OH1}	RMO terminal, V _{OUT} = 2.1 V	—	—	-5.0	mA
High level output current 2	I _{OH2}	P00 to P03 terminal V _{OUT} = 2.1 V	—	—	-2.0	mA
High level output current 3	I _{OH3}	P10, P11 terminal V _{OUT} = 2.6 V	—	—	-100	μA
Low level output current 1	I _{OL1}	RMO terminal, V _{OUT} = 0.4 V	250	—	—	μA
Low level output current 2	I _{OL2}	P00 to P03 terminal V _{OUT} = 0.9 V	5	—	—	mA
Low level output current 3	I _{OL3}	Output port, V _{OUT} = 0.4 V	1.0	—	—	mA
Schmitt hysteresis width	V _{WD}		—	0.7	—	V

Table 5 DC Characteristics (II)

(Ta = -20°C to +70°C, V_{DD} = 5.0 V)

Item	Symbol	Conditions	Min.	Typ.	Max.	Unit
Operating current consumption	I _{CCO}	System clock : 455 KHz	—	1.2	2.0	mA
Standby current consumption	I _{CCS}	At STOP mode	—	0.1	5	μA
High level input voltage	V _{IH}		0.8 × V _{DD}	—	—	V
Low level input voltage	V _{IL}		—	—	0.2 × V _{DD}	V
High level input leakage current	I _{IH}	All input terminals V _{IN} = V _{DD}	—	—	1	μA
Low level input leakage current	I _{IL}	Without pull-up resistor V _{IN} = V _{SS}	-1	—	—	μA
High level input current	I _{IH}	RESET terminal V _{IN} = V _{DD}	3	9	27	μA
Low level input current 1	I _{IL1}	With pull-up resistor V _{IN} = V _{SS}	-270	-90	-30	μA
Low level input current 2	I _{IL2}	RESET terminal V _{IN} = V _{SS} + 0.3 V	3	9	27	μA
High level output current 1	I _{OH1}	RMO terminal, V _{OUT} = 2.1 V	—	—	-8.0	mA
High level output current 2	I _{OH2}	P00 to P03 terminal V _{OUT} = 4.1 V	—	—	-3.0	mA
High level output current 3	I _{OH3}	P10, P11 terminal V _{OUT} = 4.6 V	—	—	-250	μA
Low level output current 1	I _{OL1}	RMO terminal, V _{OUT} = 0.4 V	500	—	—	μA
Low level output current 2	I _{OL2}	P00 to P03 terminal V _{OUT} = 0.9 V	6.0	—	—	mA
Low level output current 3	I _{OL3}	Output port, V _{OUT} = 0.4 V	2.0	—	—	mA
Schmitt hysteresis width	V _{WD}		—	1.3	—	V

**CMOS 4-bit 1-chip MICROCOMPUTER
S-13P48A**

■ Instructions

Table 6

	Basic	Including addressing modes
Transfer instruction	13	27
Arithmetic operation instruction	34	47
Logical operation instruction	7	13
Branch instruction	21	21
Shift instruction	2	4
Special instruction	2	2
Total	79	114

■ Application Example

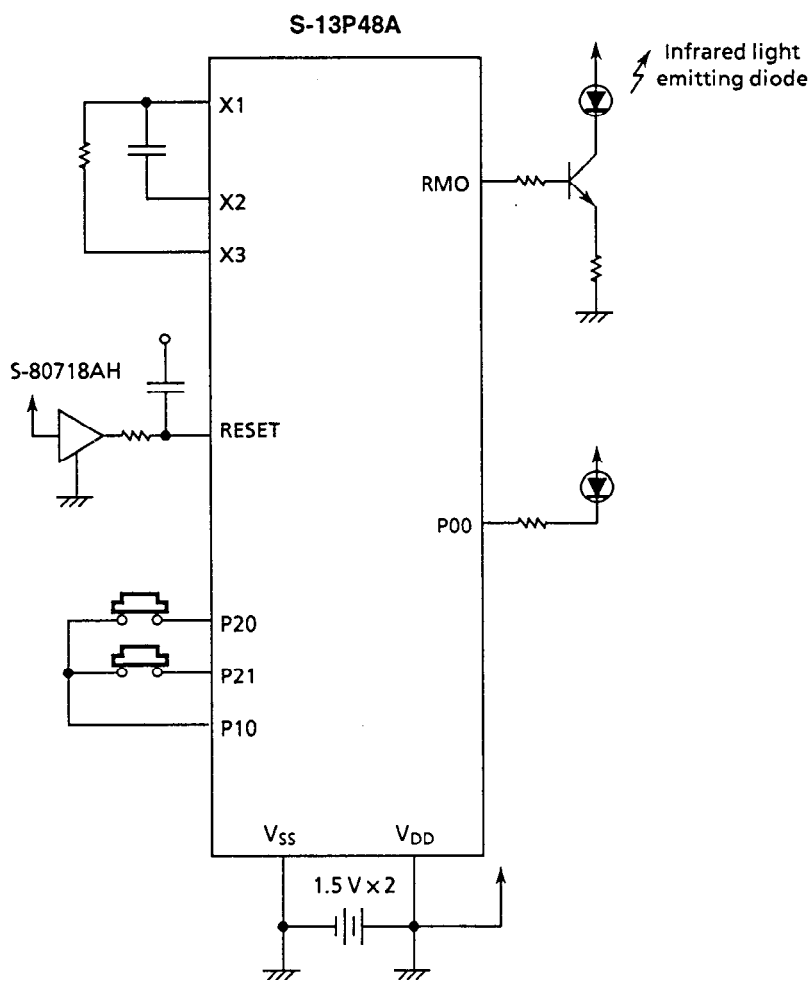

Figure 4