

Contents

Features 1
Pin Assignment 1
Block Diagram 2
Operation Mode 2
Absolute Maximum Ratings 2
Recommended Operating Conditions ... 2
DC Electrical Characteristics 3
Rewriting Times 3
Pin Capacitance 3
AC Electrical Characteristics 4
Operation 8
Dimensions 9
Ordering Information 10
Characteristics 11

The S-2812A and the S-2817A are low power 2K×8-bit parallel E²PROMs. The S-2812A features wide operating voltage range, and the S-2817A features 5-V single power supply. Since provided with 32-byte page write function, they can perform fast programming operation.

■ Features

- Access time: 150 ns
(V_{CC} = 5 V ± 10%, T_a = 0°C to 70°C)
- Low power consumption
Operating: 30 mA max. (V_{CC} = 5 V ± 10%)
Standby: 1 μA max. (V_{CC} = 5 V ± 10%)
- Operating voltage range

<u>S-2812A</u>	<u>S-2817A</u>
Read: 1.8 to 5.5 V	5 V ± 10%
Write: 2.7 to 5.5 V	5 V ± 10%
- Write inhibition
S-2812A: 2.1 V typ.
S-2817A: 3.5 V typ.
- Data polling
- With Ready/Busy pin
- Page write for 32 bytes
- Rewritings: 10⁵ times
- Data retention: 10 years
- Program noise immunity
- Package: 28-pin DIP/SOP/TSOP
- Supply in bare chip is also available

■ Pin Assignment

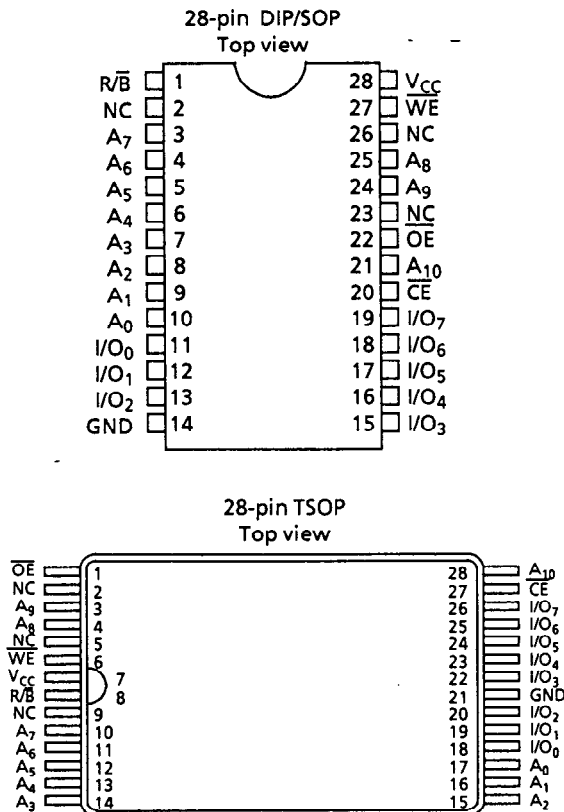

Pin name	Function
A ₀ to A ₁₀	Address input
I/O ₀ to I/O ₇	Data input / output
<u>CE</u>	Chip Enable
<u>OE</u>	Output Enable
<u>WE</u>	Write Enable
R/B	Ready/Busy (opendrain output)
V _{CC}	Power supply voltage
GND	Ground (0 V)

Figure 1

CMOS 16K-bit PARALLEL E²PROM S-2812A/2817A

Block Diagram

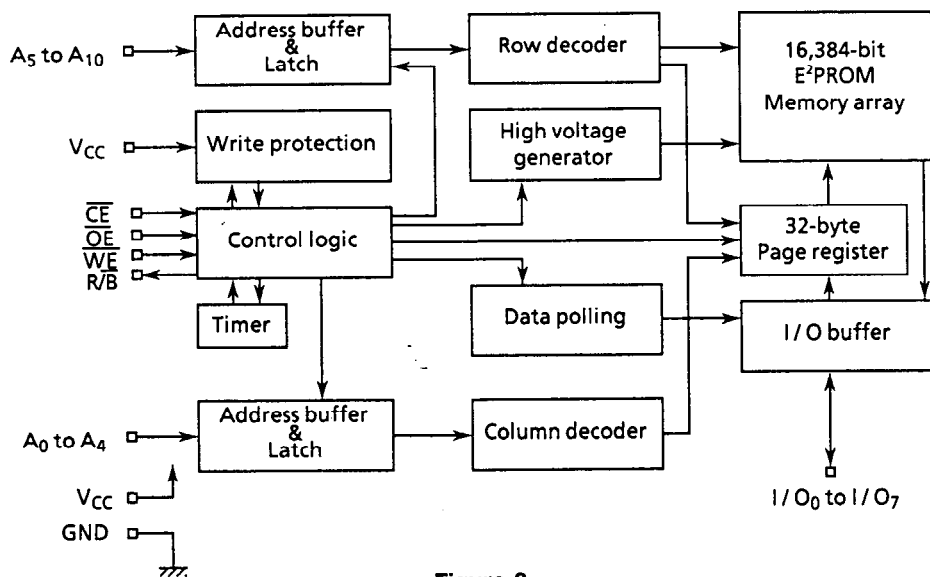

Figure 2

Operation Mode

Table 1

Mode	\overline{CE}	\overline{OE}	\overline{WE}	I/O
Read	L	L	H	Data output
Write	L	H	L	Data input
Write inhibition	x	x	H	—
	x	L	x	—
Standby	H	x	x	High-Z

X: Don't care

Absolute Maximum Ratings

Table 2

Parameter	Symbol	Ratings	Unit
Power supply voltage	V _{CC}	-0.3 to +7.0	V
Input voltage	V _{IN}	-0.3 to V _{CC} + 0.3	V
Output voltage	V _{OUT}	-0.3 to V _{CC}	V
Storage temperature under bias	T _{bias}	-50 to +95	°C
Storage temperature	T _{stg}	-65 to +150	°C

Recommended Operating Conditions

Table 3

Parameter	Symbol	Conditions	Min.	Typ.	Max.	Unit	
Power supply voltage	V _{CC}	S-2812A	Read	1.8	—	5.5	V
		S-2817A	Write	2.7	—	5.5	V
					4.5	5.0	5.5
High level input voltage	V _{IH}	V _{CC} = 2.7 to 5.5 V	2.2	—	V _{CC} + 0.3	V	
		V _{CC} = 1.8 to 2.7 V	0.8 × V _{CC}	—	V _{CC} + 0.3	V	
Low level input voltage	V _{IL}	V _{CC} = 5 V ± 10%	-0.3	—	0.8	V	
		V _{CC} = 2.7 to 4.5 V	-0.3	—	0.4	V	
		V _{CC} = 1.8 to 2.7 V	-0.3	—	0.2 × V _{CC}	V	
Operating temperature	T _{opr}		-40	—	85	°C	

■ DC Electrical Characteristics

1. S-2812A

Table 4

(Ta = -40°C to 85°C)

Parameter	Symbol	Conditions	5 V ± 10%			3 V ± 10%			Unit
			Min.	Typ.	Max.	Min.	Typ.	Max.	
Current consumption (Read)	I _{CC1}	$\overline{CE} \leq V_{IL}, V_{IN} \leq V_{IL} \text{ or } V_{IN} \geq V_{IH}$ I _{OUT} = 0 mA, f = 1/t _{RC}	—	—	30	—	—	15	mA
	I _{CC2}	$\overline{CE} \leq 0.2 \text{ V}, V_{IN} \leq 0.2 \text{ V or } V_{IN} \geq V_{CC} - 0.2 \text{ V}$ I _{OUT} = 0 mA, f = 1/t _{RC}	—	—	25	—	—	10	mA
Current consumption (Program)	I _{CC3}	$\overline{CE} \leq V_{IL}, V_{IN} \leq V_{IL} \text{ or } V_{IN} \geq V_{IH}$	—	—	30	—	—	15	mA
	I _{CC4}	$\overline{CE} \leq 0.2 \text{ V}, V_{IN} \leq 0.2 \text{ V or } V_{IN} \geq V_{CC} - 0.2 \text{ V}$	—	—	25	—	—	10	mA
Standby current	I _{SB1}	$\overline{CE} \geq V_{IH}$	—	—	1	—	—	0.5	mA
	I _{SB2}	$\overline{CE} \geq V_{CC} - 0.2 \text{ V}$	—	—	1.0	—	—	1.0	μA
Input leakage current	I _{LI}	V _{IN} = GND to V _{CC}	—	—	1.0	—	—	1.0	μA
Output leakage current	I _{LO}	V _{I/O} = GND to V _{CC}	—	—	1.0	—	—	1.0	μA
High level output voltage	V _{OH}	5-V operation: I _{OH} = -400 μA 3-V operation: I _{OH} = -100 μA	2.4	—	—	2.4	—	—	V
Low level output voltage	V _{OL}	5-V operation: I _{OL} = 2.1 mA 3-V operation: I _{OL} = 400 μA	—	—	0.4	—	—	0.4	V

2. S-2817A

Table 5

(Ta = -40°C to 85°C, V_{CC} = 5 V ± 10%)

Parameter	Symbol	Conditions	Min.	Typ.	Max.	Unit
Current consumption (Read)	I _{CC1}	$\overline{CE} \leq V_{IL}, V_{IN} \leq V_{IL} \text{ or } V_{IN} \geq V_{IH}$ I _{OUT} = 0 mA, f = 1/t _{RC}	—	—	30	mA
	I _{CC2}	$\overline{CE} \leq 0.2 \text{ V}, V_{IN} \leq 0.2 \text{ V or } V_{IN} \geq V_{CC} - 0.2 \text{ V}$ I _{OUT} = 0 mA, f = 1/t _{RC}	—	—	25	mA
Current consumption (Program)	I _{CC3}	$\overline{CE} \leq V_{IL}, V_{IN} \leq V_{IL} \text{ or } V_{IN} \geq V_{IH}$	—	—	30	mA
	I _{CC4}	$\overline{CE} \leq 0.2 \text{ V}, V_{IN} \leq 0.2 \text{ V or } V_{IN} \geq V_{CC} - 0.2 \text{ V}$	—	—	25	mA
Standby current	I _{SB1}	$\overline{CE} \geq V_{IH}$	—	—	1	mA
	I _{SB2}	$\overline{CE} \geq V_{CC} - 0.2 \text{ V}$	—	—	1.0	μA
Input leakage current	I _{LI}	V _{IN} = GND to V _{CC}	—	—	1.0	μA
Output leakage current	I _{LO}	V _{I/O} = GND to V _{CC}	—	—	1.0	μA
High level output voltage	V _{OH}	I _{OH} = -400 μA	2.4	—	—	V
Low level output voltage	V _{OL}	I _{OL} = 2.1 mA	—	—	0.4	V

■ Rewriting Times

Table 6

Parameter	Symbol	Min.	Typ.	Max.	Unit
Rewriting times	N _W	10 ⁵	—	—	times/byte

■ Pin Capacitance

Table 7

Parameter	Symbol	Conditions	Min.	Typ.	Max.	Unit
Input capacitance	C _{IN}	V _{IN} = 0 V	—	—	10	pF
Input/output capacitance	C _{I/O}	V _{I/O} = 0 V	—	—	10	pF

■ AC Electrical Characteristics

Table 8 Measuring conditions

Parameter	S-2812A	S-2817A
Input pulse levels	V _{IL} = 0.2 V V _{IH} = 2.4 V	V _{IL} = 0.4 V V _{IH} = 2.4 V
Input rise and fall time	10 ns	10 ns
I/O reference level	1.5 V	1.5 V
Output load	See Figure 3	See Figure 3

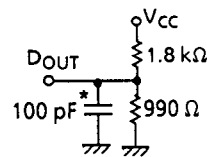

* (When measuring t_{CLZ}, t_{OLZ}, t_{CHZ}, t_{OHZ}, t_{WHZ}, t_{WLZ}) : 5pF

Figure 3 Output load measuring circuit

1. Read Cycle

(1) 5-V operation

Table 9

(V_{CC} = 5 V ± 10%)

Parameter	Symbol	0°C to 70°C		- 40°C to 85°C		Unit
		Min.	Max.	Min.	Max.	
Read cycle time	t _{RC}	150	—	200	—	ns
$\overline{\text{CE}}$ access time	t _{CE}	—	150	—	200	ns
Address access time	t _{AA}	—	150	—	200	ns
$\overline{\text{OE}}$ access time	t _{OE}	—	70	—	90	ns
Output enable time ($\overline{\text{CE}}$)	t _{CLZ}	10	—	10	—	ns
Output enable time ($\overline{\text{OE}}$)	t _{OLZ}	10	—	10	—	ns
Output disable time ($\overline{\text{CE}}$)	t _{CHZ}	10	70	10	90	ns
Output disable time ($\overline{\text{OE}}$)	t _{OHZ}	10	70	10	90	ns
Output data hold time	t _{OH}	5	—	5	—	ns

(2) 3-V operation (S-2812A only)

Table 10

(V_{CC} = 3 V ± 10%)

Parameter	Symbol	0°C to 70°C		- 40°C to 85°C		Unit
		Min.	Max.	Min.	Max.	
Read cycle time	t _{RC}	400	—	500	—	ns
$\overline{\text{CE}}$ access time	t _{CE}	—	400	—	500	ns
Address access time	t _{AA}	—	400	—	500	ns
$\overline{\text{OE}}$ access time	t _{OE}	—	200	—	250	ns
Output enable time ($\overline{\text{CE}}$)	t _{CLZ}	25	—	30	—	ns
Output enable time ($\overline{\text{OE}}$)	t _{OLZ}	25	—	30	—	ns
Output disable time ($\overline{\text{CE}}$)	t _{CHZ}	25	200	30	250	ns
Output disable time ($\overline{\text{OE}}$)	t _{OHZ}	25	200	30	250	ns
Output data hold time	t _{OH}	10	—	15	—	ns

2. Write Cycle

(1) 5-V operation

Table 11

(V_{CC} = 5 V ± 10%)

Parameter	Symbol	0°C to 70°C		- 40°C to 85°C		Unit
		Min.	Max.	Min.	Max.	
Write cycle time	t _{WC}	—	10	—	10	ms
Address setup time	t _{AS}	0	—	0	—	ns
Address hold time	t _{AH}	120	—	150	—	ns
Write setup time	t _{CS}	0	—	0	—	ns
Write hold time	t _{CH}	0	—	0	—	ns
$\overline{\text{CE}}$ pulse width	t _{CW}	120	—	150	—	ns
$\overline{\text{OE}}$ setup time	t _{OES}	15	—	20	—	ns
$\overline{\text{OE}}$ hold time	t _{OEH}	15	—	20	—	ns
$\overline{\text{WE}}$ pulse width	t _{WP}	120	—	150	—	ns
Data setup time	t _{DS}	85	—	100	—	ns
Data hold time	t _{DH}	0	—	0	—	ns
Page load time (page data setting time)	t _{PL}	0.3	30	0.3	30	μs
Page load time (page data write start time)	t _{PDL}	100	—	100	—	μs
Time to device busy	t _{DB}	110	—	140	—	ns

(2) 3-V operation (S-2812A only)

Table 12

(V_{CC} = 3 V ± 10%)

Parameter	Symbol	0°C to 70°C		- 40°C to 85°C		Unit
		Min.	Max.	Min.	Max.	
Write cycle time	t _{WC}	—	10	—	10	ms
Address setup time	t _{AS}	0	—	0	—	ns
Address hold time	t _{AH}	300	—	350	—	ns
Write setup time	t _{CS}	0	—	0	—	ns
Write hold time	t _{CH}	0	—	0	—	ns
$\overline{\text{CE}}$ pulse width	t _{CW}	300	—	350	—	ns
$\overline{\text{OE}}$ setup time	t _{OES}	30	—	35	—	ns
$\overline{\text{OE}}$ hold time	t _{OEH}	30	—	35	—	ns
$\overline{\text{WE}}$ pulse width	t _{WP}	300	—	350	—	ns
Data setup time	t _{DS}	180	—	210	—	ns
Data hold time	t _{DH}	0	—	0	—	ns
Page load time (page data setting time)	t _{PL}	0.3	30	0.3	30	μs
Page load time (page data write start time)	t _{PDL}	100	—	100	—	μs
Time to device busy	t _{DB}	250	—	300	—	ns

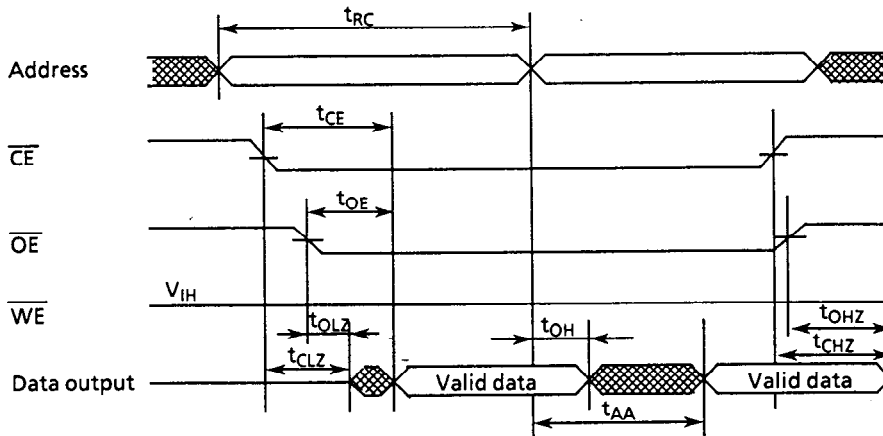

Figure 4 Read cycle

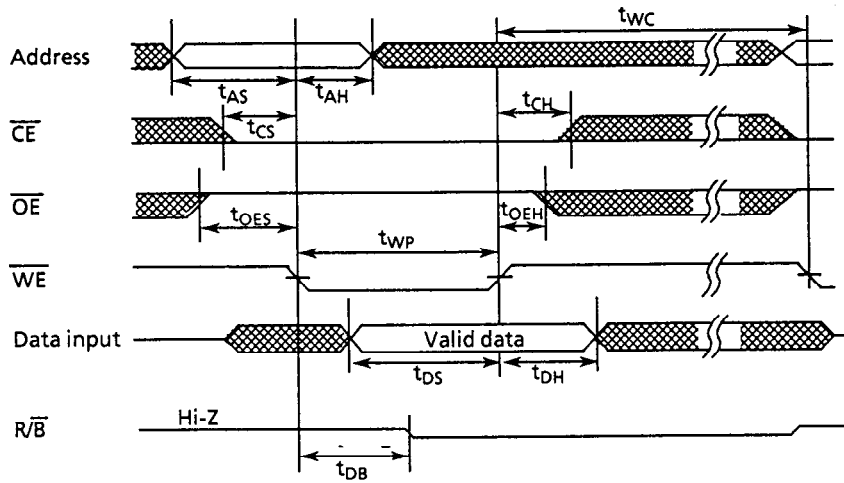

Figure 5 \overline{WE} controlled write cycle

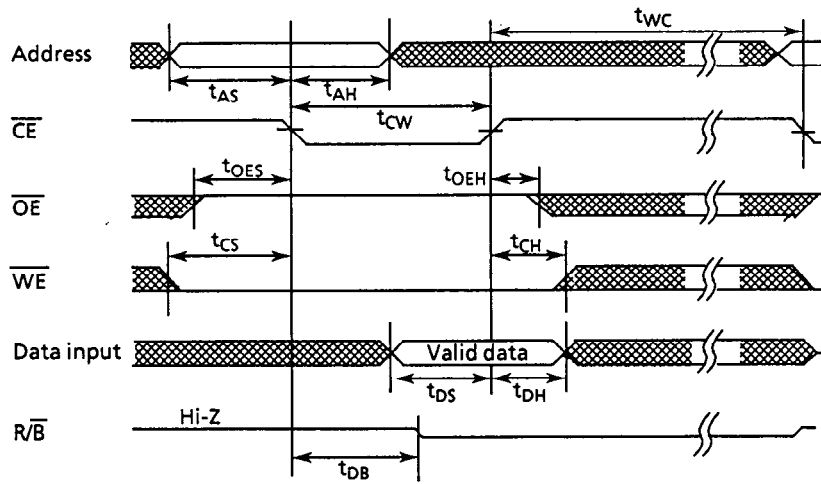

Figure 6 \overline{CE} controlled write cycle

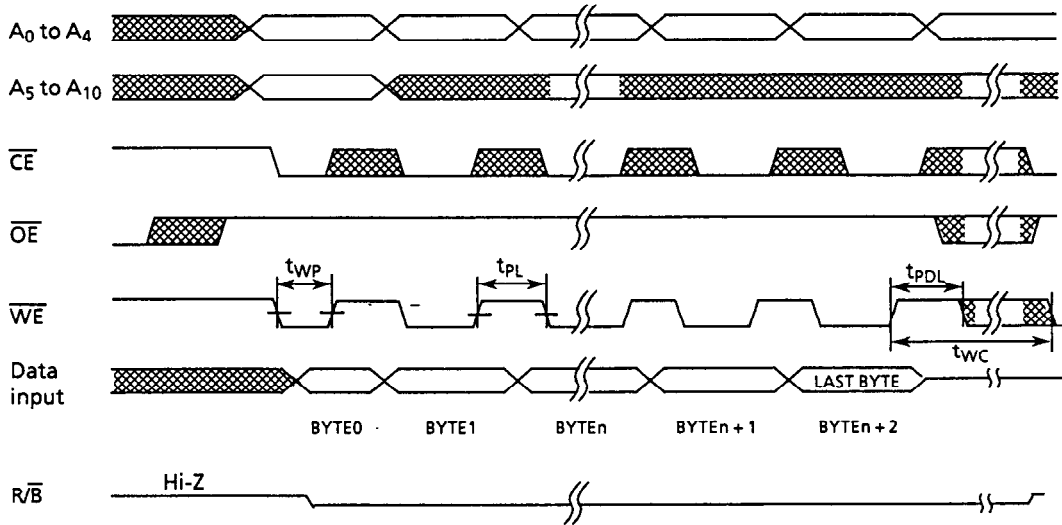

Figure 7 Page write cycle

■ **Operation**

(1) **Read mode**

This mode outputs data to I/O₀ to I/O₇ when both \overline{CE} and \overline{OE} are low and when \overline{WE} is high. The data bus is high impedance when either \overline{CE} or \overline{OE} is high.

(2) **Byte write mode**

A byte write cycle starts when both \overline{CE} and \overline{WE} are low and \overline{OE} is high. \overline{CE} - and \overline{WE} -controlled write cycles are available. The address is latched at the falling of \overline{CE} or \overline{WE} whichever occurs last, and the data is latched at the rising of \overline{CE} or \overline{WE} whichever occurs first.

(3) **Page write mode**

In this mode, 1 page program operation of 32 bytes is completed in 10 ms, and all memory area is written within a second because the device organization is 64-page × 32-byte. When starting this mode, first, addresses A₅ to A₁₀ assign the page, then A₀ to A₄ assign the address to each byte within the page sequentially or at random. Less than 32 bytes of program is available. This address assignment is performed while $0.3 \mu\text{s} \leq t_{PL} \leq 30 \mu\text{s}$, and the program operation starts when $t_{PDL} \geq 100 \mu\text{s}$.

(4) **Data polling**

This function is to output the complement data written last on I/O₇ and to output low to I/O₀ to I/O₆. This operation is performed by read operation during write cycle. R/ \overline{B} outputs low during write cycle; it is in high impedance in other modes.

(5) **Erase all mode**

All data is erased when \overline{OE} is 13 V and both \overline{CE} and \overline{WE} are low. During erase all mode, A₀ to A₁₀ and I/O₀ to I/O₇ must be fixed to either high or low.

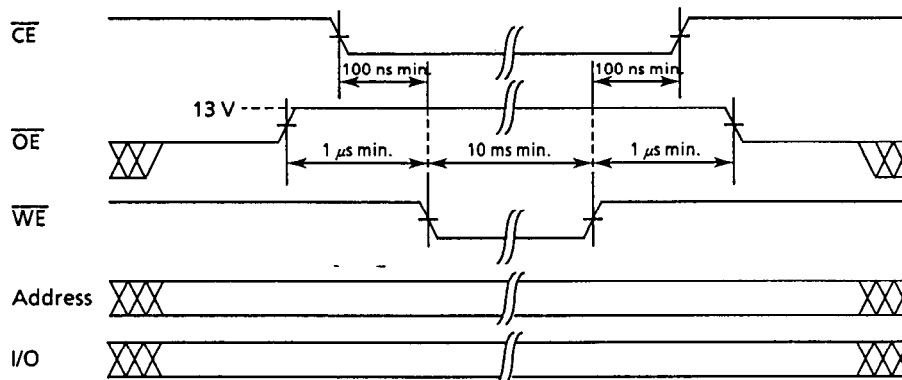

Figure 8

(6) **Write inhibition**

Write operation is inhibited in the following cases :

- When power supply voltage is under write inhibit voltage (V_{WI}).
S-2817A : $V_{WI} = 3.5 \text{ V typ.}$
S-2812A : $V_{WI} = 2.1 \text{ V typ.}$
- When \overline{OE} is low, or \overline{WE} is high.

(7) **Program noise immunity**

\overline{CE} , \overline{OE} and \overline{WE} are noise protected for preventing erroneous write operation at power on and off. Less than 20 ns write pulse will not activate a write cycle at 5-V operation, and less than 50 ns at 3-V operation. See Figure 9.

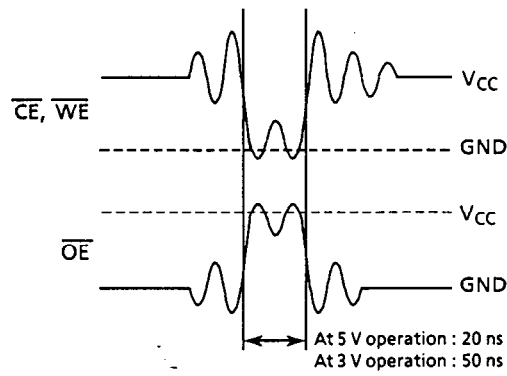

Figure 9

■ Dimensions (Unit : mm)

1. 28-pin DIP

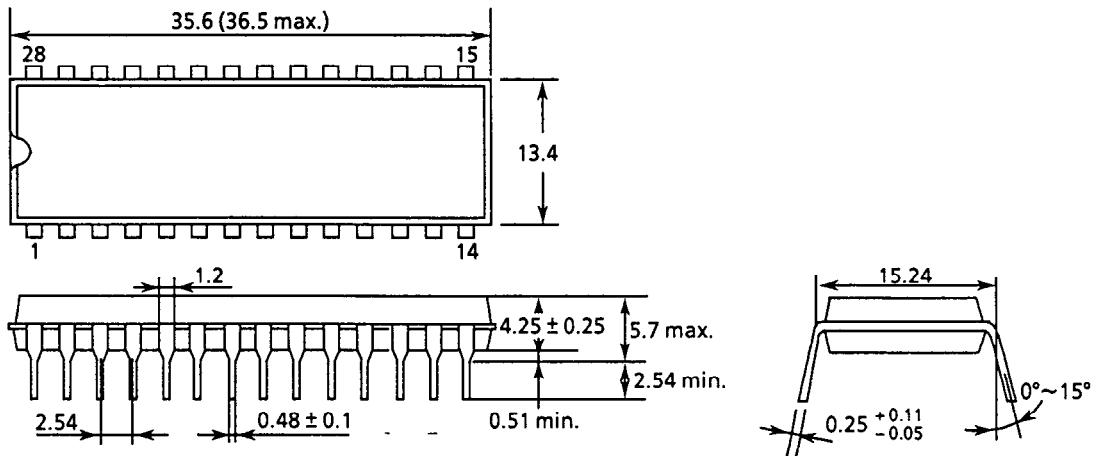

Figure 10

2. 28-pin SOP

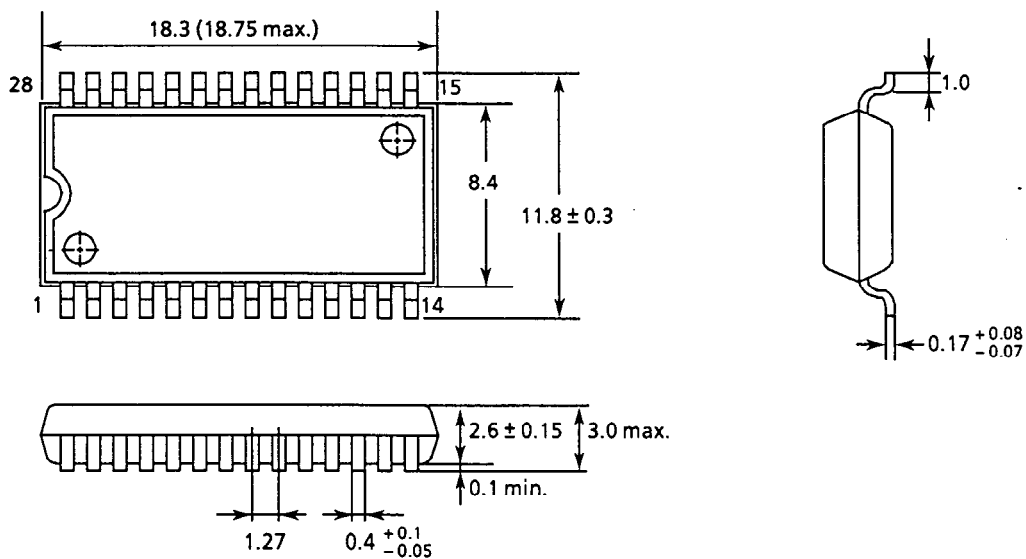

Figure 11

CMOS 16K-bit PARALLEL E²PROM
S-2812A/2817A

3. 28-pin TSOP

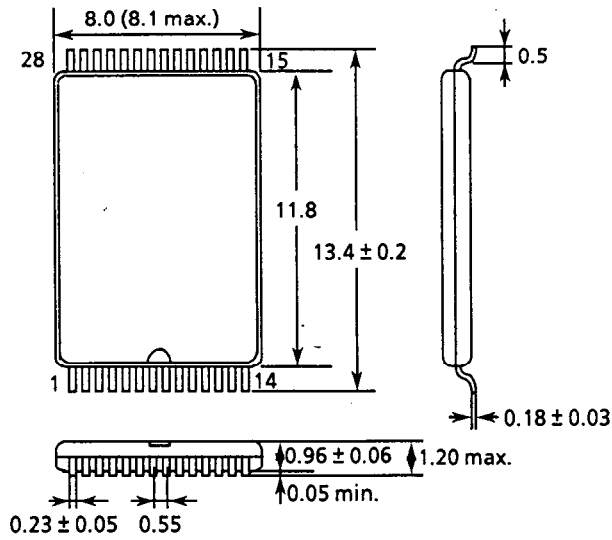
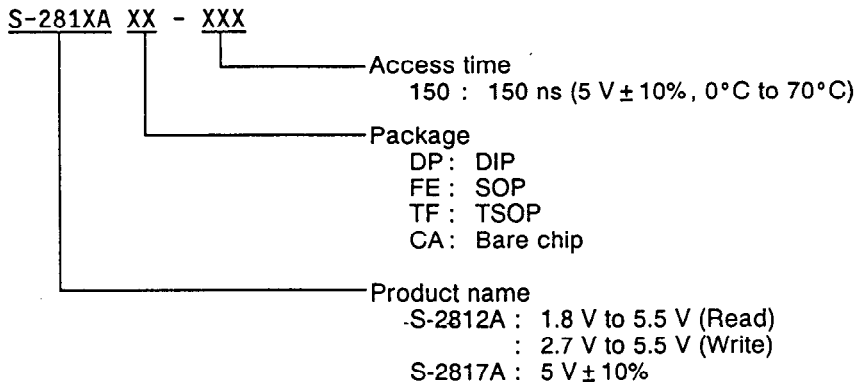

Figure 12

■ Ordering Information



Note: Each bit is set to 1 before delivery (except bare chip)

■ Characteristics

1. DC characteristics

1.1 Current consumption (READ) I_{CC1} – Ambient temperature T_a

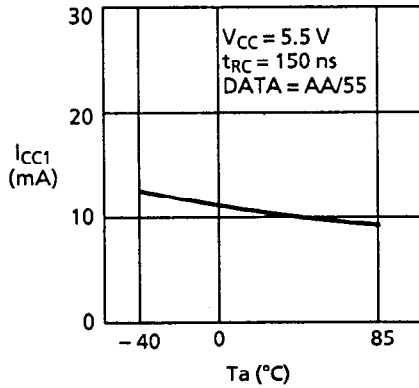

1.2 Current consumption (READ) I_{CC1} – Ambient temperature T_a

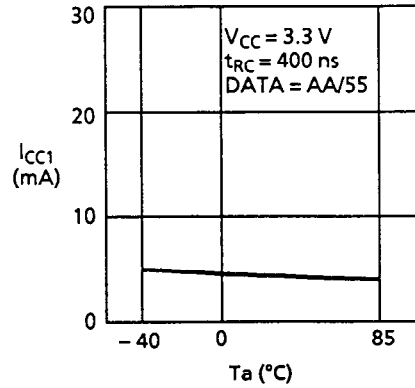

1.3 Current consumption (READ) I_{CC1} – Power supply voltage V_{CC}

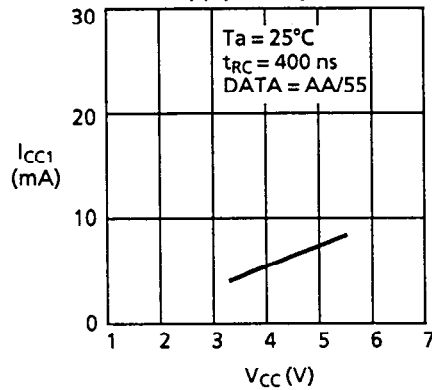

1.4 Current consumption (READ) I_{CC1} – Read cycle time t_{RC}

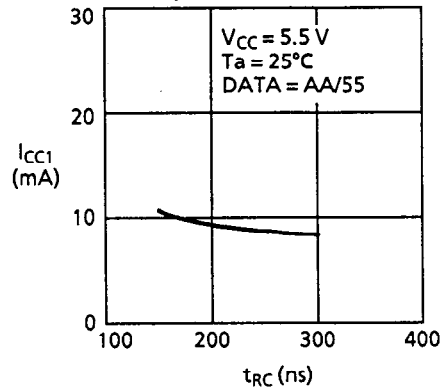

1.5 Current consumption (READ) I_{CC2} – Ambient temperature T_a

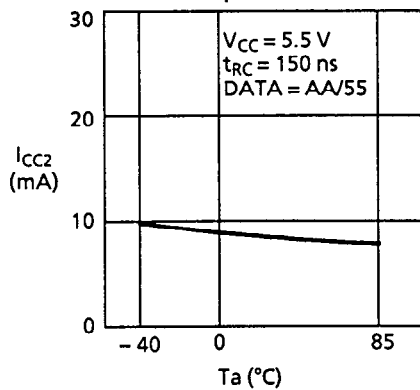

1.6 Current consumption (READ) I_{CC2} – Ambient temperature T_a

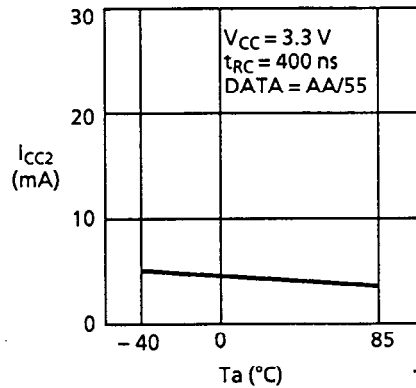

1.7 Current consumption (READ) I_{CC2} – Power supply voltage V_{CC}

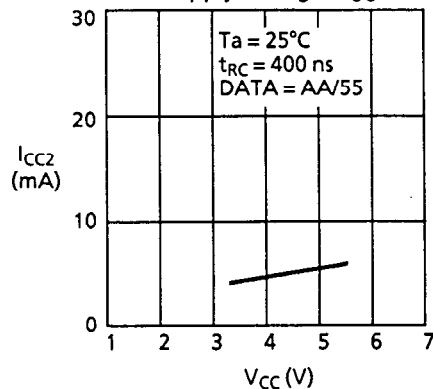

1.8 Current consumption (READ) I_{CC2} – Read cycle time t_{RC}

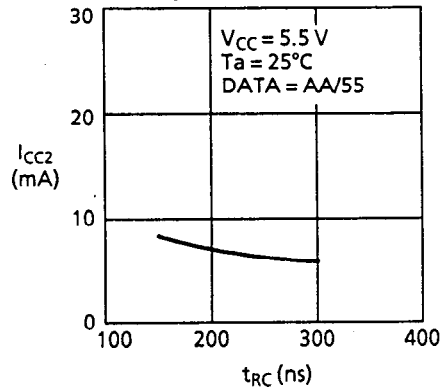

**CMOS 16K-bit PARALLEL E²PROM
S-2812A/2817A**

1.9 Current consumption (PROGRAM) I_{CC3} – Ambient temperature T_a

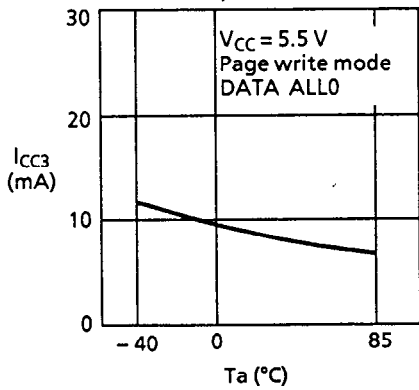

1.10 Current consumption (PROGRAM) I_{CC3} – Ambient temperature T_a

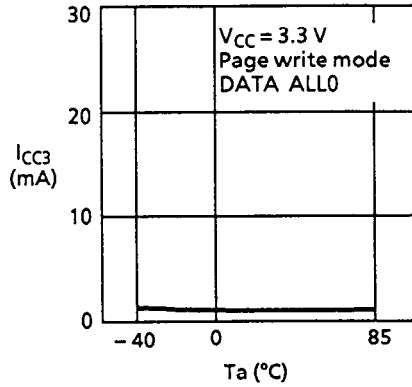

1.11 Current consumption (PROGRAM) I_{CC3} – Power Supply Voltage V_{CC}

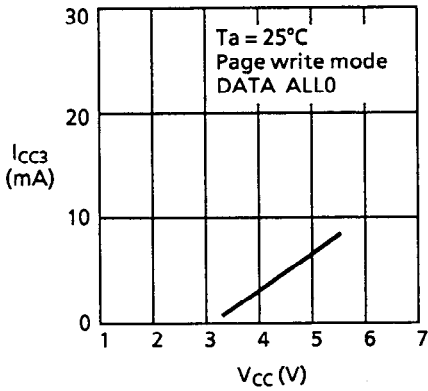

1.12 Current consumption (PROGRAM) I_{CC3} – Ambient temperature T_a

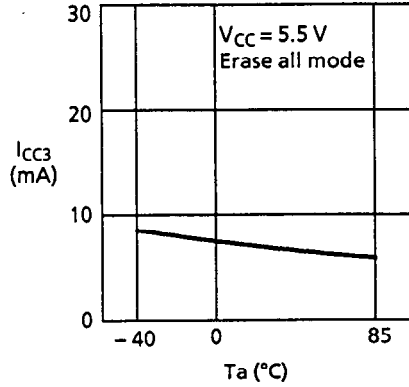

1.13 Current consumption (PROGRAM) I_{CC4} – Ambient temperature T_a

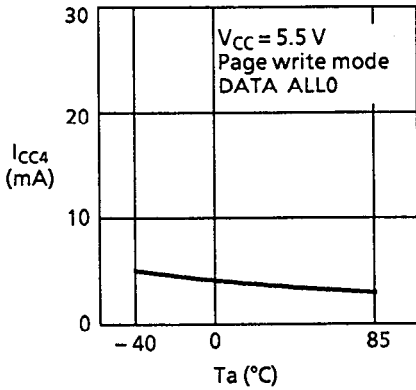

1.14 Current consumption (PROGRAM) I_{CC4} – Ambient temperature T_a

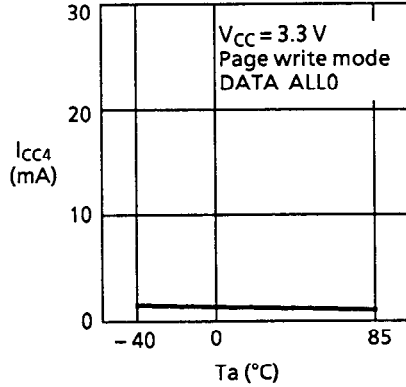

1.15 Current consumption (PROGRAM) I_{CC4} – Power Supply Voltage V_{CC}

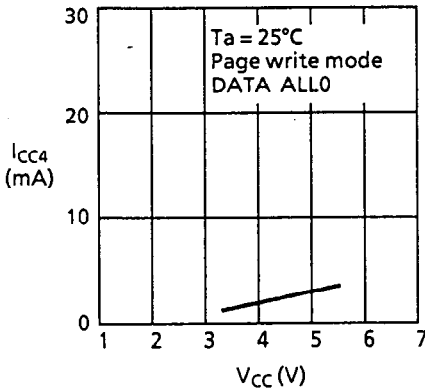

1.16 Current consumption (PROGRAM) I_{CC4} – Ambient temperature T_a

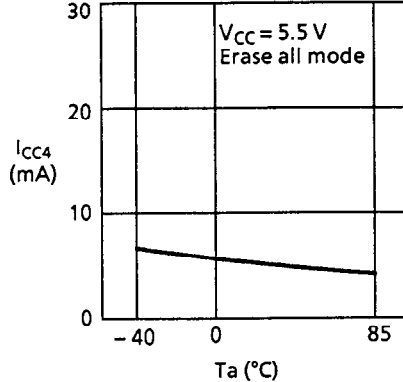

1.17 Standby current I_{SB1} – Ambient temperature T_a

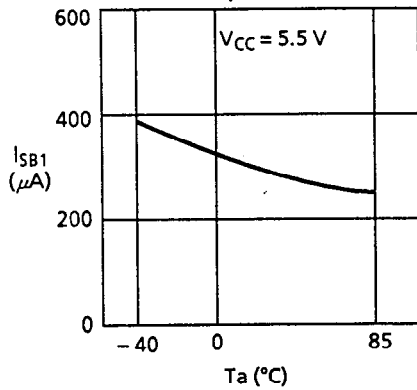

1.18 Standby current I_{SB1} – Ambient temperature T_a

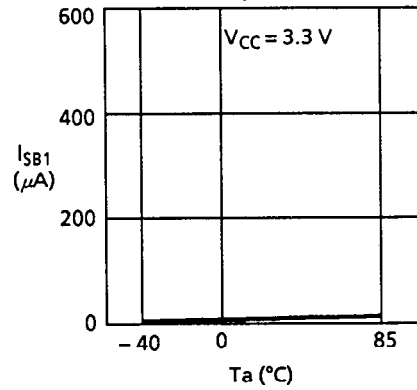

1.19 Standby current I_{SB2} – Ambient temperature T_a

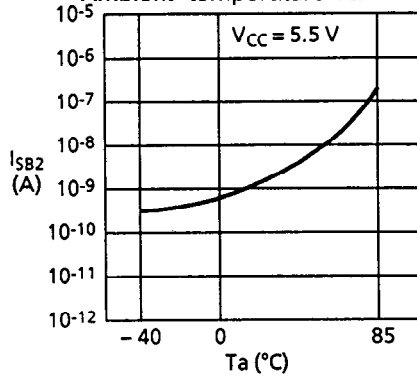

1.20 Standby current I_{SB2} – Ambient temperature T_a

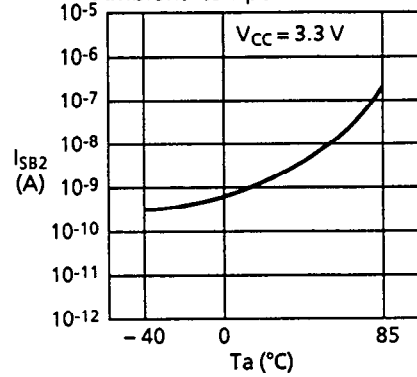

1.21 Input leakage current I_{LI} – Ambient temperature T_a

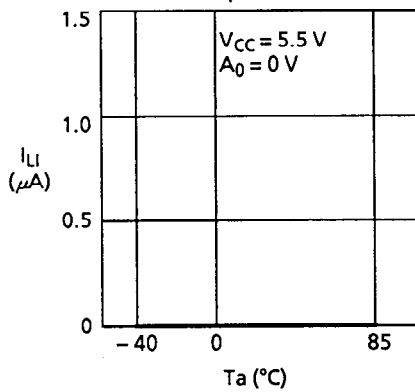

1.22 Input leakage current I_{LI} – Ambient temperature T_a

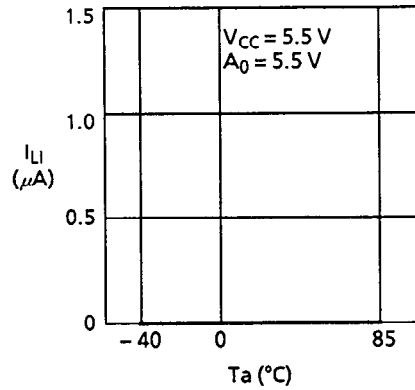

1.23 Output leakage current I_{LO} – Ambient temperature T_a

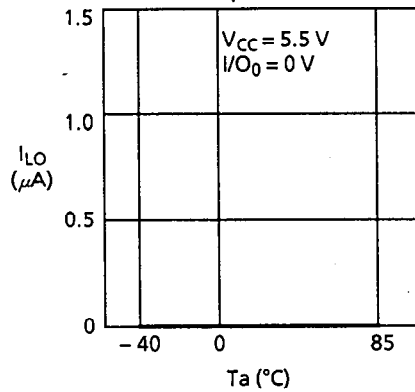

1.24 Output leakage current I_{LO} – Ambient temperature T_a

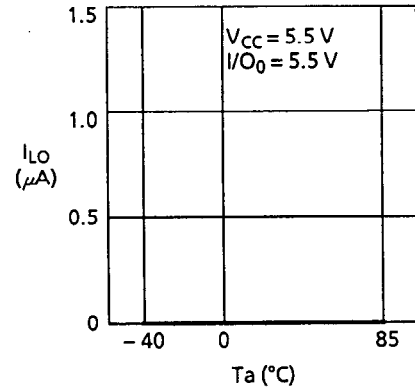

**CMOS 16K-bit PARALLEL E²PROM
S-2812A/2817A**

1.25 High level output voltage V_{OH} – Ambient temperature T_a

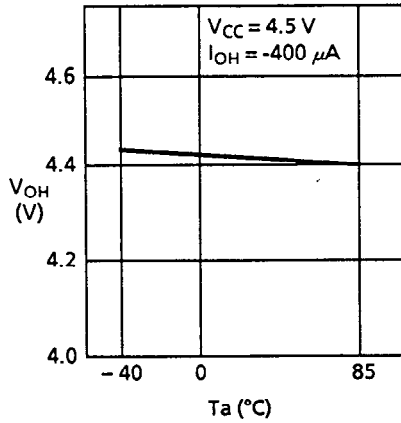

1.26 High level output voltage V_{OH} – Ambient temperature T_a

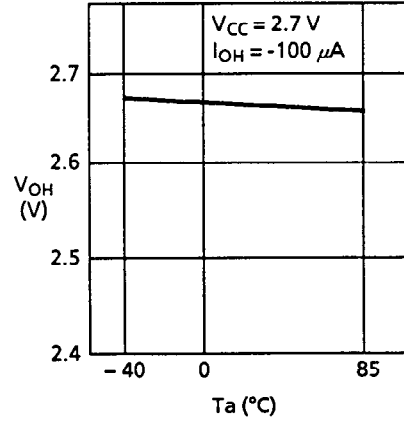

1.27 Low level output voltage V_{OL} – Ambient temperature T_a

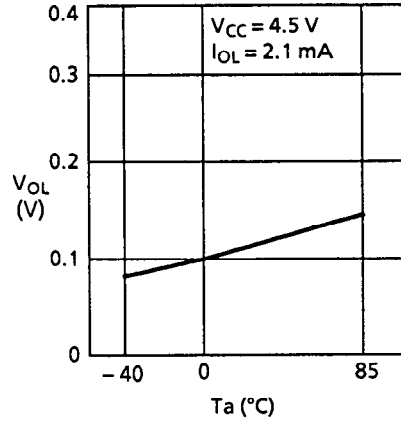

1.28 Low level output voltage V_{OL} – Ambient temperature T_a

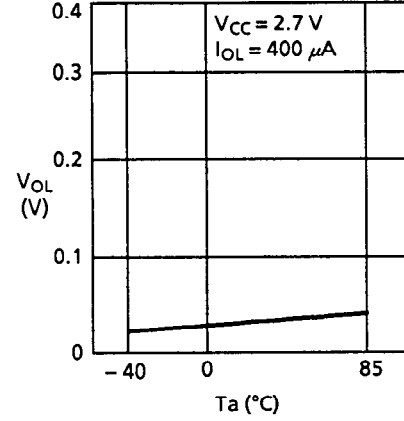

1.29 High level input voltage V_{IH} – Ambient temperature T_a

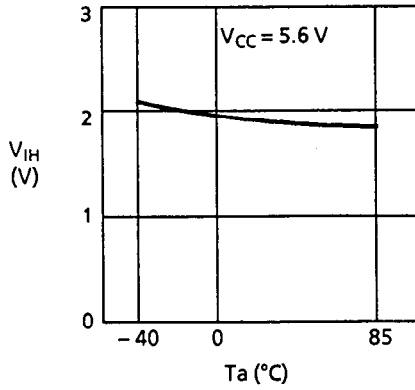

1.30 Low level input voltage V_{IL} – Ambient temperature T_a

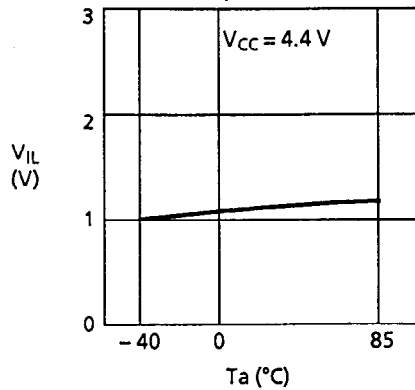

1.31 Low level input voltage V_{IL} – Ambient temperature T_a

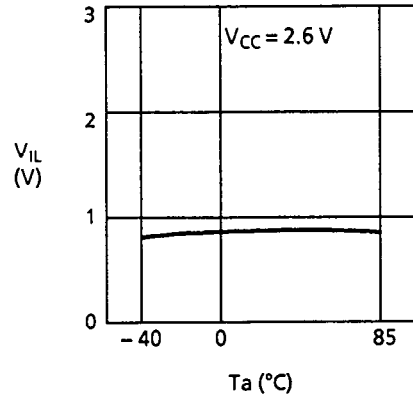

2. AC characteristics

2.1 Write cycle time t_{WC} – Ambient temperature T_a

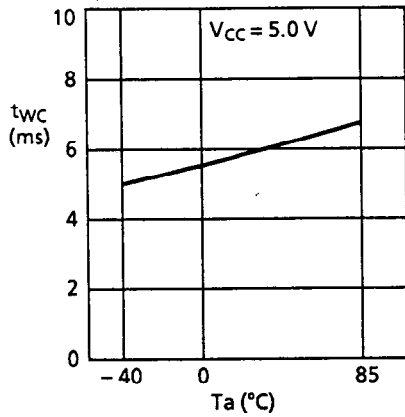

2.2 Write cycle time t_{WC} – Ambient temperature T_a

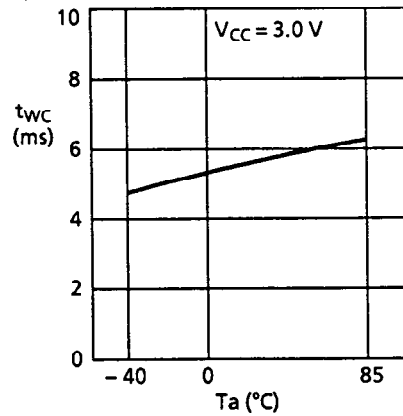

2.3 Write cycle time t_{WC} – Power supply voltage V_{CC}

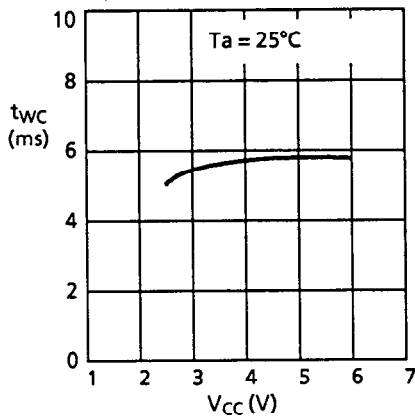

2.4 Address access time t_{AA} – Ambient temperature T_a

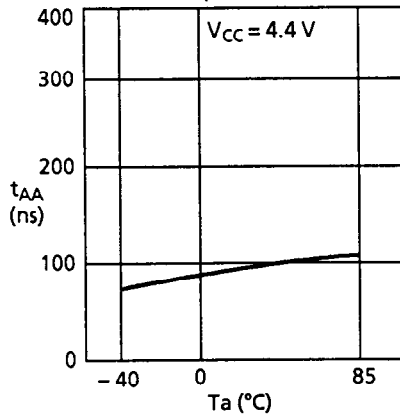

2.5 Address access time t_{AA} – Ambient temperature T_a

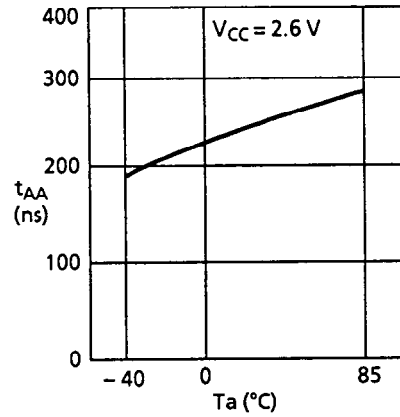

2.6 \overline{CE} access time t_{CE} – Ambient temperature T_a

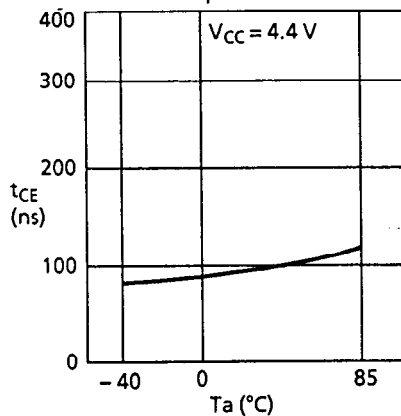

2.7 \overline{CE} access time t_{CE} – Ambient temperature T_a

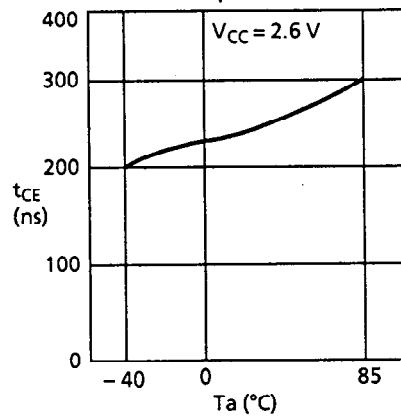

**CMOS 16K-bit PARALLEL E²PROM
S-2812A/2817A**

2.8 \overline{OE} access time t_{OE} –
Ambient temperature T_a

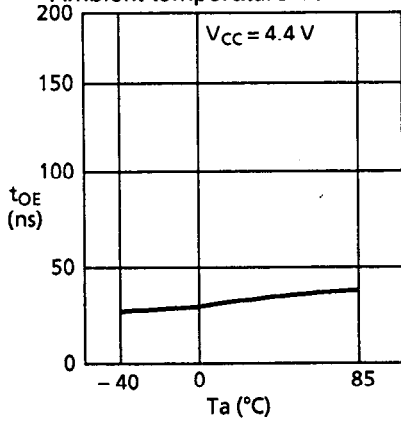

2.9 \overline{OE} access time t_{OE} –
Ambient temperature T_a

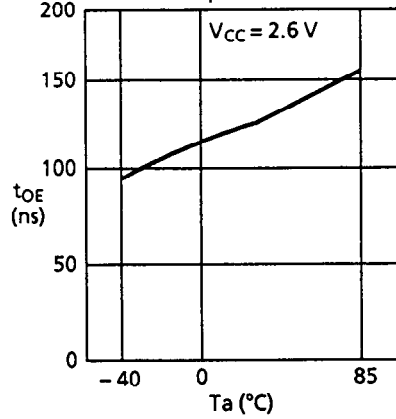

2.10 Address setup time t_{AS} –
Ambient temperature T_a

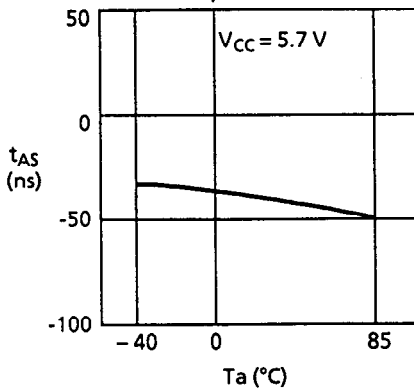

2.11 Address hold time t_{AH} –
Ambient temperature T_a

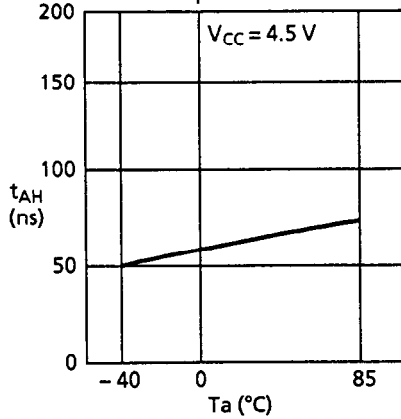

2.12 Address hold time t_{AH} –
Ambient temperature T_a

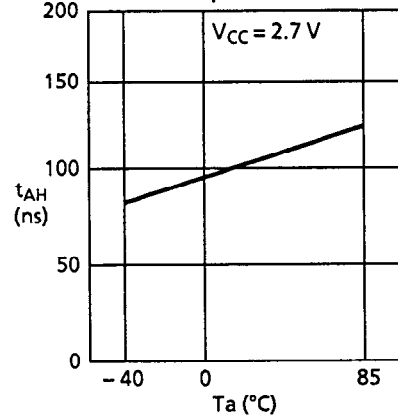

2.13 Data setup time t_{DS} –
Ambient temperature T_a

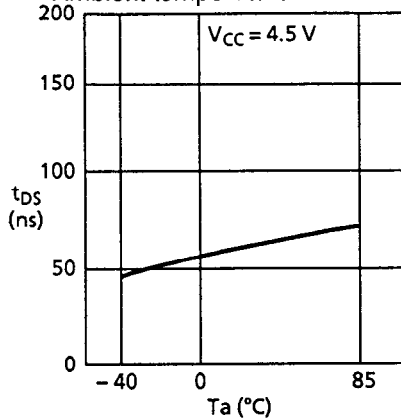

2.14 Data setup time t_{DS} –
Ambient temperature T_a

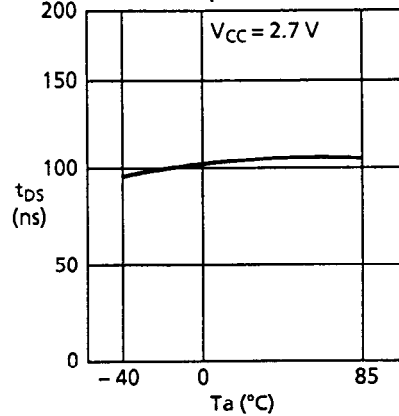

2.15 Data hold time t_{DH} -
Ambient temperature T_a

