



SPX1431

Precision Adjustable Shunt Regulator

FEATURES

- Voltage Tolerance 0.4%
- Wide Operating Current 1mA to 150mA
- Extended Temperature Range -55°C to 125°C
- Low Temperature Coefficient 30 ppm/°C
- **Improved** Replacement in Performance for **LT1431**
- Offered In Small Low Power SOT-89 Package
- **Low Output Noise**

APPLICATIONS

- Battery Operating Equipment
- Adjustable Supplies
- Switching Power Supplies
- Error Amplifiers
- Single Supply Amplifiers
- Monitors / VCR / TV
- Personal Computers

PRODUCT DESCRIPTION

The SPX1431 is a 3-terminal Adjustable Shunt Voltage Regulator providing a highly accurate 0.4% bandgap reference. SPX1431 acts as an open-loop error amplifier with a 2.5V temperature compensation reference. The SPX1431 thermal stability, wide operating current (150mA) and temperature range (125°C) makes it suitable for all varieties of applications that are looking for a low cost solution with high performance. **SPX1431 tolerance of 0.4% is proven to be sufficient to overcome all of the other errors in the system to virtually eliminate the need for trimming in the power supply manufactures assembly line and contribute a significant cost savings.**

In the standard shunt configuration, the combination of low temperature coefficient (T.C.), sharp turn-on characteristics, low output impedance and programmable output voltage that makes this precision reference an excellent error amplifier.

The SPX1431 is a direct improved replacement for the SPX431 and TL431 in low voltage, low current applications.

PIN CONFIGURATIONS

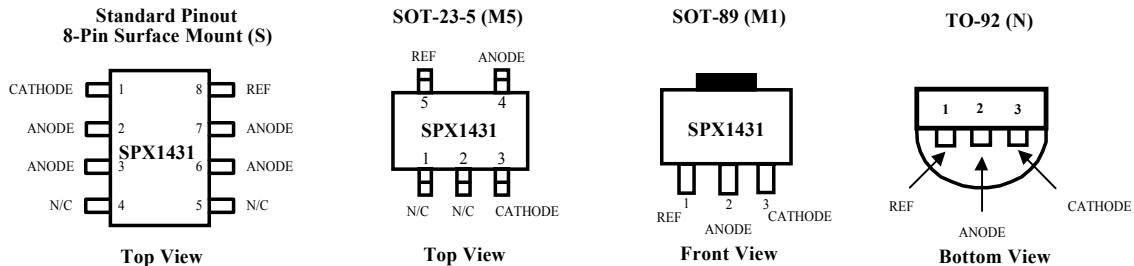

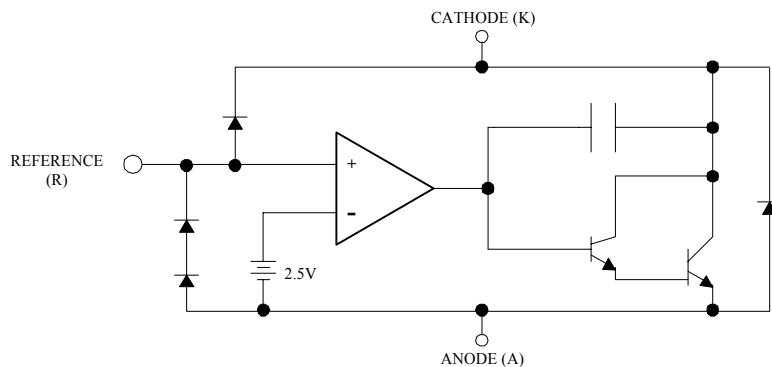

ABSOLUTE MAXIMUM RATINGS

Parameter	Symbol	Rating	Units
Cathode-Anode Reverse Breakdown	V_{KA}	37	V
Anode-Cathode Forward Current	I_{AK}	1	A
Operating Cathode Current	I_{KA}	250	mA
Reference Input Current	I_{REF}	10	mA
Continuous Power Dissipation at 25°C	P_D		
TO-92		775	mW
SOT-23		200	mW
8L SOIC		750	mW
SOT-89		1000	mW
Junction Temperature	T_J	150	°C
Storage Temperature	T_{STG}	- 65 to 150	°C
Lead Temperature (Soldering 10 sec.)	T_L	300	°C

Stresses greater than those listed under ABSOLUTE MAXIMUM RATINGS may cause permanent damage to the device. This is a stress rating only and functional operation of the device at these or any other conditions above those indicated in the operational sections of this specification is not implied. Exposure to absolute maximum rating conditions for extended periods may affect reliability.

RECOMMENDED CONDITIONS

PARAMETER	SYMBOL	RATING	UNIT
Cathode Voltage	V_{KA}	V_{REF} to 20	V
Cathode Current	I_K	10	mA

TYPICAL THERMAL RESISTANCES

PACKAGE	θ_{JA}	θ_{JC}	TYPICAL DERATING
TO-92	160° C/W	80° C/W	6.3 mW/°C
SOT-23	575° C/W	150° C/W	1.7 mW/°C
SOIC	175° C/W	45° C/W	5.7 mW/°C
SOT-89	110° C/W	8° C/W	9.1 mW/°C

ELECTRICAL CHARACTERISTICS are guaranteed over full junction temperature range (-55°C to 125°C). Ambient temperature must be derated based on power dissipation and package thermal characteristics. The conditions are: $V_{KA} = V_{REF}$ and $I_K = 10\text{mA}$, unless otherwise specified.

Parameter	Symbol	Test Conditions	Test Circuit	Min	Typ	Max	Units
Reference Voltage	V_{REF}	$T_A = 25^\circ\text{C}$	1	2.490	2.500	2.510	V
		Over Temp.	1	2.465		2.535	V
V_{REF} with Temp*	TC		1		0.06	0.16	mV/°C
Ratio of Change in V_{REF} to Cathode Voltage	V_{REF}	$V_K = 3\text{V to }36\text{V}$	2	-2	-1.1		mV/V
Reference Input Current	I_{REF}	$R_1 = 10\text{ k}; R_2 =$	2		0.7	1.9	μA
I_{REF} Temp Deviation	I_{REF}	Over Temp.	2		0.4	1.2	μA
Min I_K for Regulation	$I_{K(\text{min})}$		1		0.4	1	mA
Off State Leakage	$I_{K(\text{off})}$	$V_{REF} = 0\text{V}, V_{KA} = 36\text{V}$	3		0.04	250	nA
Dynamic Output Impedance	Z_{KA}	$f \leq 1\text{ kHz } I_K 1\text{ to }100\text{mA}$	1		0.15	0.2	Ω

Calculating Average Temperature Coefficient (TC)

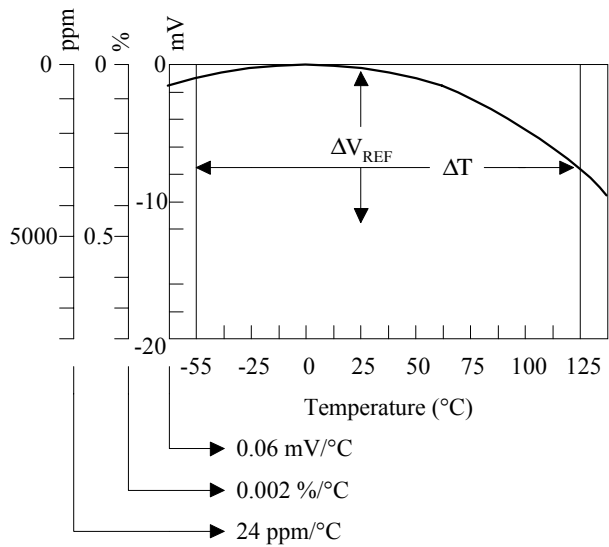

- $\text{TC in mV}/^\circ\text{C} = \frac{\Delta V_{REF} \text{ (mV)}}{\Delta T_A}$
- $\text{TC in } \%/^\circ\text{C} = \frac{\left(\frac{\Delta V_{REF}}{V_{REF} \text{ at } 25^\circ\text{C}} \right)}{\Delta T_A} \times 100$
- $\text{TC in ppm}/^\circ\text{C} = \frac{\left(\frac{\Delta V_{REF}}{V_{REF} \text{ at } 25^\circ\text{C}} \right)}{\Delta T_A} \times 10^6$

TEST CIRCUITS

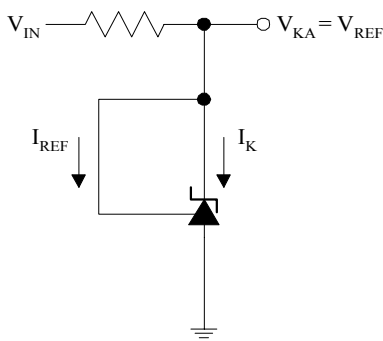

Figure 1a. Test Circuit 1

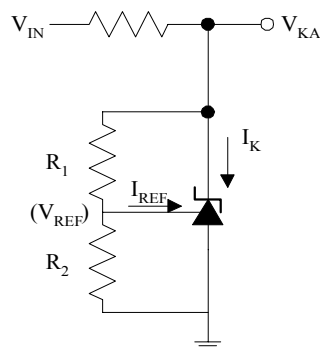

Figure 1b. Test Circuit 2

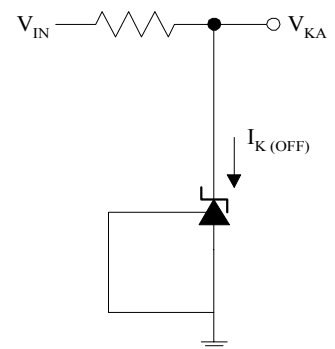

Figure 1c. Test Circuit 3

TYPICAL PERFORMANCE CURVES

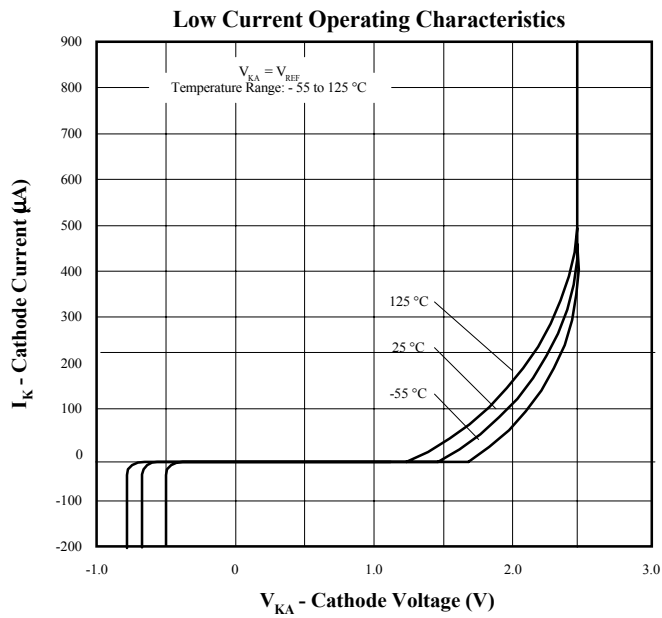

Figure 2

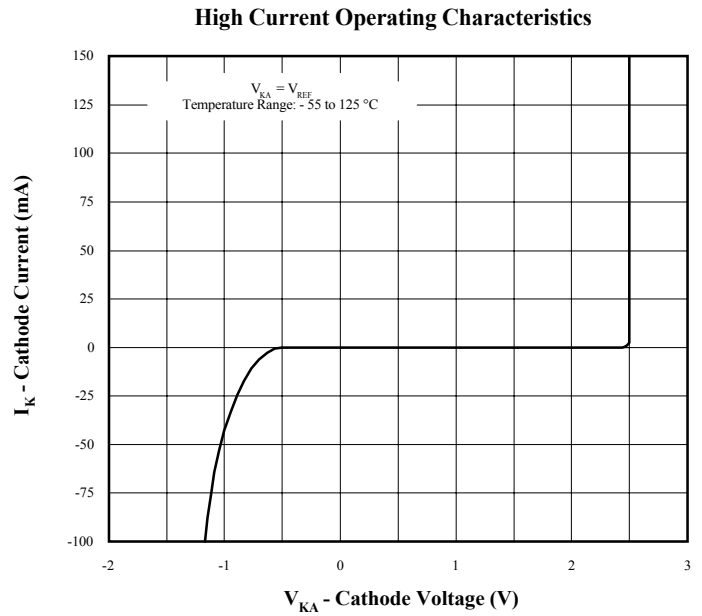

Figure 3

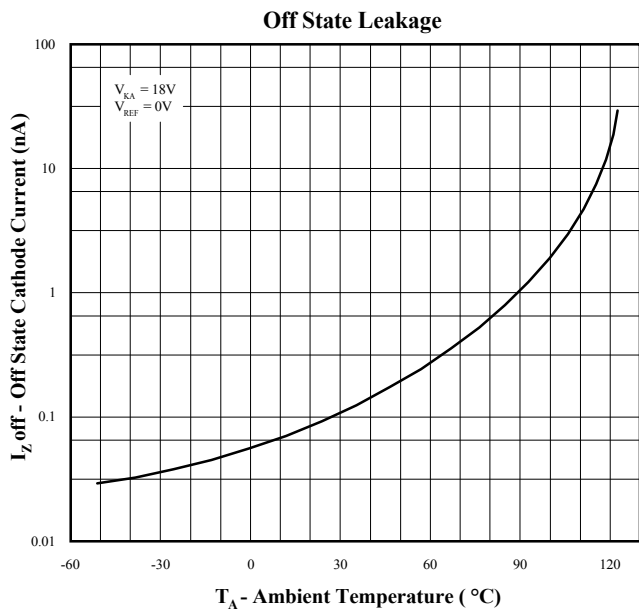

Figure 4

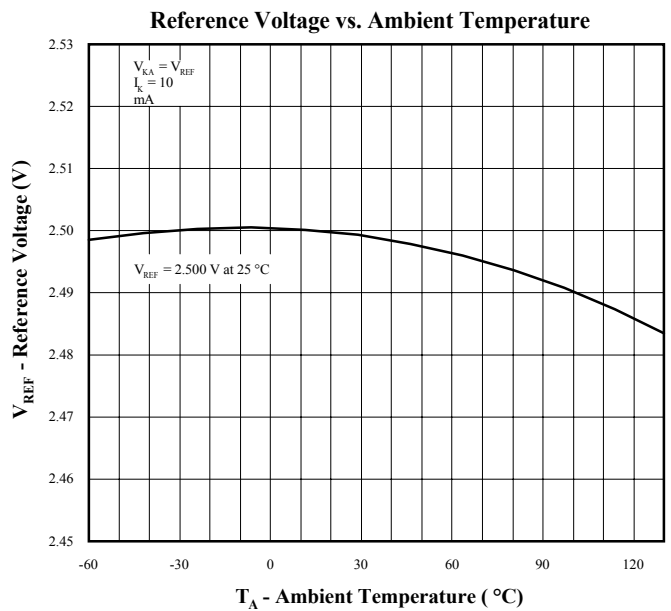

Figure 5

TYPICAL PERFORMANCE CURVES

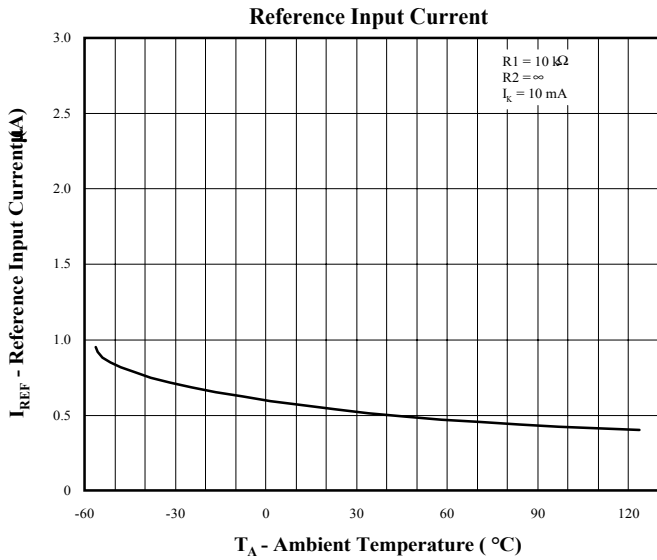

Figure 6

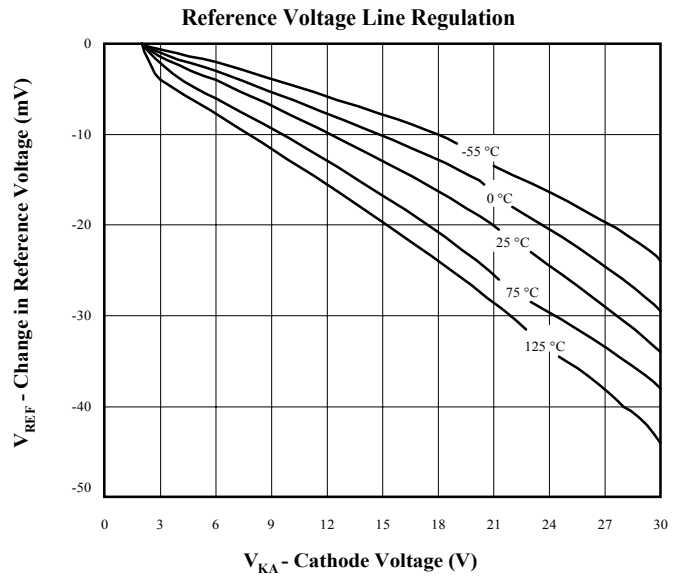

Figure 7

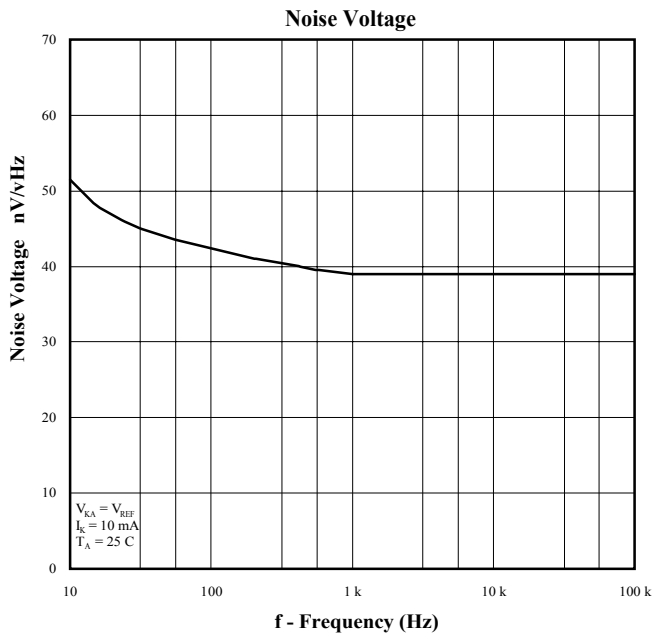

Figure 8

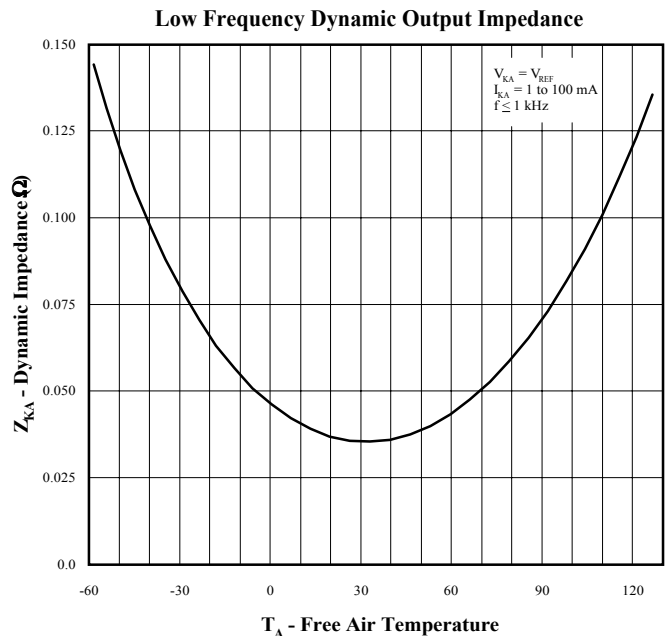
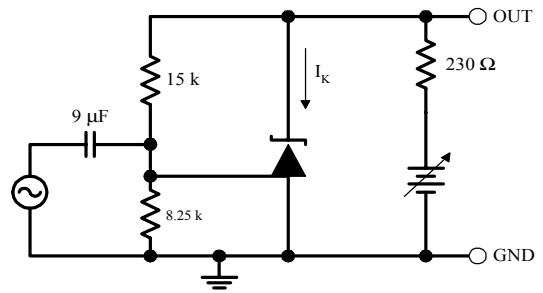
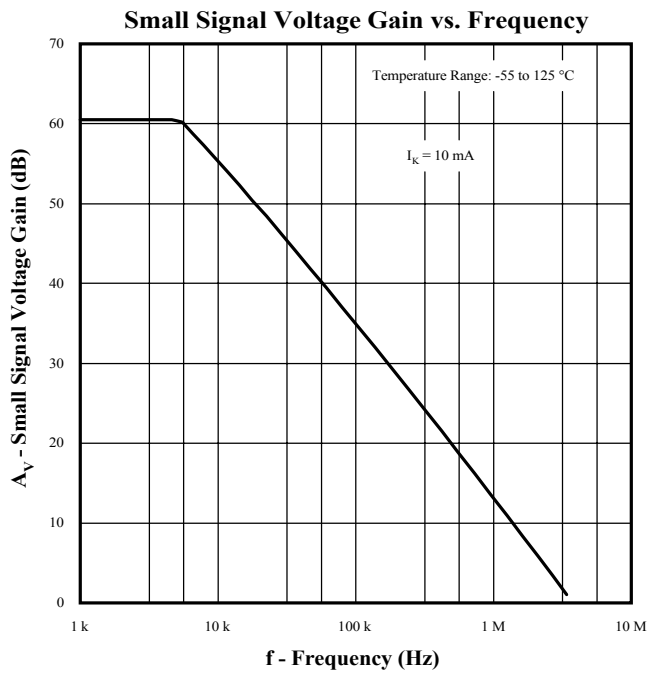
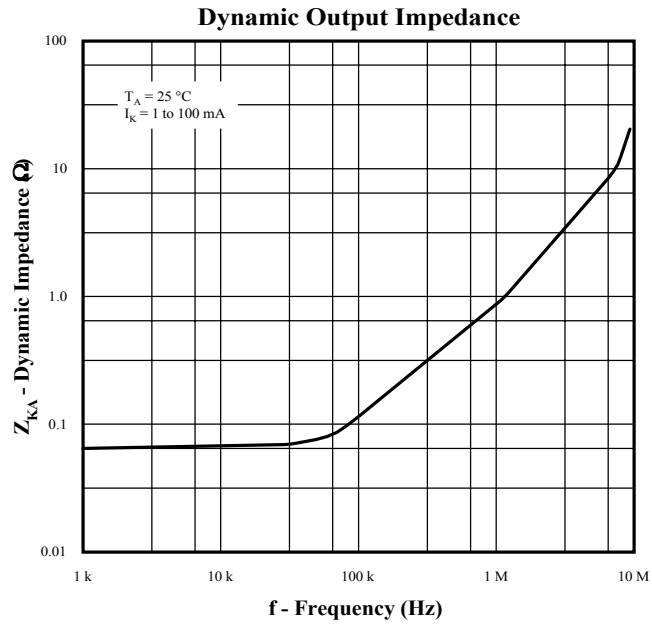

Figure 9

TYPICAL PERFORMANCE CURVES



TYPICAL PERFORMANCE CURVES

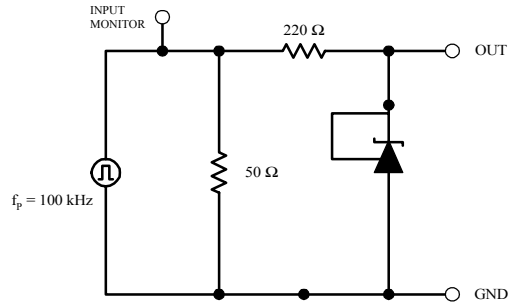
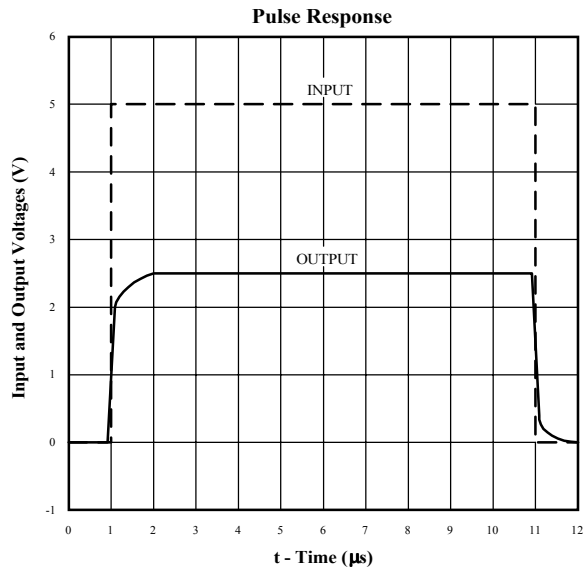

Figure 12

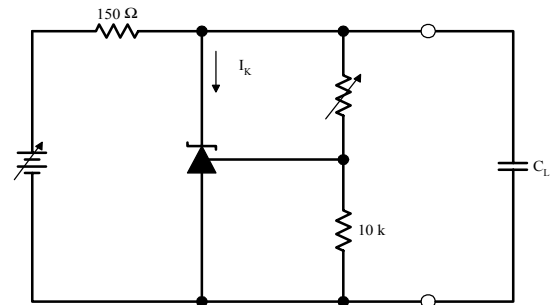
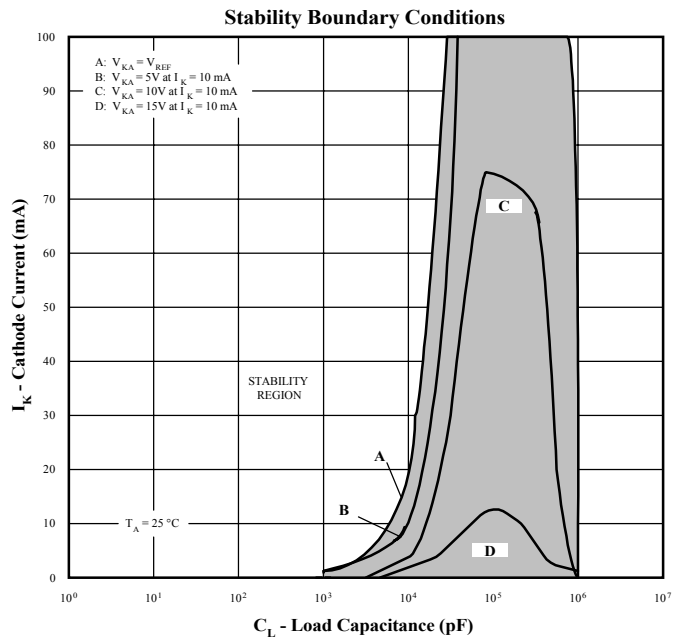

Figure 13

ORDERING INFORMATION

Ordering No.	Precision	Output Voltage	Packages
SPX1431M5	0.4%	2.5V	5 Lead SOT-23
SPX1431M1	0.4%	2.5V	3 Lead SOT-89
SPX1431S	0.4%	2.5V	8 Lead SOIC
SPX1431N	0.4%	2.5V	3 Lead TO-92



SIGNAL PROCESSING EXCELLENCE

Sipex Corporation

Headquarters and Main Offices:

22 Linnell Circle
Billerica, MA 01821
TEL: (978) 667-8700
FAX: (978) 670-9001
e-mail: sales@sipex.com

233 South Hillview Drive
Milpitas, CA 95035
TEL: (408) 935-7600
FAX: (408) 934-7500

Sipex Corporation reserves the right to make changes to any products described herein. Sipex does not assume any liability arising out of the application or use of any product or circuit described hereing; neither does it convey any license under its patent rights nor the rights of others.