



## SPX1581

### 5A Ultra Low Dropout Voltage Regulator Fast Response, Adjustable & Fixed

#### FEATURES

- Low Dropout Voltage 500mV at 5A Full Load Current
- Adjustable Output Down to 1.2V from ATX Power Supply
- Fixed Output Voltages of 3.3V, 2.8V & 2.5V
- Extremely Tight Voltage and Line Regulation
- Standard 5-Terminal Low Cost TO-220 & TO-263

#### APPLICATIONS

- 3.3V to 2.8V ATX Power Supplies
- 3.3V to 2.9V for Portable PENTIUM™ Processor
- 5V to 3.5V VRE Supply
- High Efficiency “Green” Computer Systems

#### PRODUCT DESCRIPTION

The SPX1581 is a 5A Low Dropout Regulator with extremely low dropout voltage. The adjustable version requires only two external resistors to set the output voltage. The fixed version has a preset output of 3.3V, 2.8V or 2.5V and does not require any external resistors. The SPX1581 features a low dropout of less than 400mV(typ.) and offers fast transient response. **This device is suitable for Pentium applications requiring 2.8V or 2.5V from 3.3V ATX power supplies**, where a low current input voltage 1V greater than the output voltage is needed. With an external sense pin the load regulation is less than 1mV. This device is an excellent choice for the use in powering low voltage microprocessors that require a lower dropout, fast transient response to regulate from 3.3V and 5V supplies. The SPX1581 is also an excellent choice as a post regulator for switching supplies applications.

The SPX1581 offers full protection against over-current faults, reversed input polarity, over temperature operation and positive and negative transient voltage.

The SPX1581 is offered in a 5 pin TO-220 and TO-263 compatible with industry standard 5-terminal regulators. For 7A, 3A and 1.5A ultra low dropout versions refer to SPX1580, SPX1582 and SPX1583 data sheets respectively.

#### PIN CONNECTIONS

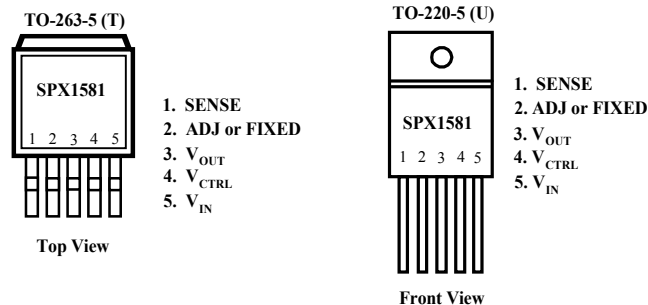

## ABSOLUTE MAXIMUM RATINGS

Power Dissipation.....	Internally Limited	Input Supply Voltage .....	6V
Lead Temp (soldering, 10 seconds).....	300°C	V <sub>CTRL</sub> Input Voltage .....	13V
Storage Temperature Range .....	-65°C to +150°C		
Operating Junction Temperature Range			
SPX1581 Control Section .....	0°C to +125°C		
SPX1581 Power Transistor .....	0°C to +150°C		

## ELECTRICAL CHARACTERISTICS at V<sub>S</sub>=14V, T<sub>a</sub>=25°C, I<sub>O</sub>=10mA, C<sub>2</sub>=100μF, unless otherwise specified. (Note 1) (Boldface applies over full temperature range).

Parameters	Conditions	SPX1581			Units
		Min	Typ	Max	
<b>2.5V Version</b>					
Output Voltage	V <sub>CTRL</sub> =6.0V to 12V, V <sub>IN</sub> =3.0V to 5.0V, I <sub>O</sub> =10mA I <sub>O</sub> =10mA to 5A	2.450 <b>2.400</b>	2.500	2.550 <b>2.600</b>	V
<b>2.8V Version</b>					
Output Voltage	V <sub>CTRL</sub> =6.3V to 12V, V <sub>IN</sub> =3.3V to 12V, I <sub>O</sub> =10mA I <sub>O</sub> =10mA to 5A	2.744 <b>2.688</b>	2.800	2.856 <b>2.912</b>	V
<b>3.3V Version</b>					
Output Voltage	V <sub>CTRL</sub> =6.3V to 12V, V <sub>IN</sub> =3.3V to 12V, I <sub>O</sub> =10mA I <sub>O</sub> =10mA to 5A	3.234 <b>3.168</b>	3.300	3.366 <b>3.462</b>	V
<b>All Voltage Options</b>					
Reference Voltage	V <sub>CTRL</sub> =2.75V, V <sub>IN</sub> =2.00V, I <sub>O</sub> =10mA V <sub>CTRL</sub> =2.7V to 12V, V <sub>IN</sub> =2.05V to 5.5V, I <sub>O</sub> =10mA to 5A	1.238	1.250	1.263	V
Line Regulation	V <sub>CTRL</sub> =2.5V to 12V, V <sub>IN</sub> =1.75V to 5.5V, I <sub>O</sub> =10mA V <sub>ADJ</sub> =0V		<b>1.0</b>	<b>3.0</b>	mV
Load Regulation (Note1)	V <sub>CTRL</sub> =2.75V, V <sub>IN</sub> =2.1V, I <sub>O</sub> =10mA to 5A, V <sub>ADJ</sub> =0V		<b>1.0</b>	<b>5.0</b>	mV
Dropout Voltage Minimum V <sub>CTRL</sub> (Note2) (V <sub>CTRL</sub> - V <sub>OUT</sub> )	V <sub>ADJ</sub> =0V V <sub>IN</sub> =2.05V, I <sub>O</sub> =1A		<b>1.10</b>	<b>1.25</b>	V
Dropout Voltage Minimum V <sub>IN</sub> (Note2) (V <sub>IN</sub> - V <sub>OUT</sub> )	V <sub>ADJ</sub> =0V V <sub>IN</sub> =2.75V, I <sub>O</sub> =5A		0.40	0.50	V
Current Limit	V <sub>CTRL</sub> =2.75V, V <sub>IN</sub> =2.05V, dV <sub>O</sub> =100mV, V <sub>ADJ</sub> =0V	<b>5.1</b>			A
Minimum Load Current	V <sub>CTRL</sub> =5V, V <sub>IN</sub> =3.3V, V <sub>ADJ</sub> =0V		<b>5</b>	<b>10</b>	mA
Thermal Regulation	30ms Pulse		0.002	0.02	%W
Ripple Rejection	V <sub>CTRL</sub> =3.75V, V <sub>IN</sub> =3.75V, I <sub>O</sub> =2.5A, V <sub>ADJ</sub> =0V T <sub>J</sub> =25, V <sub>RIPPLE</sub> =1V <sub>pp</sub> at 120Hz	60	80		dB
Control Pin Current	V <sub>ADJ</sub> =0V V <sub>CTRL</sub> =2.75V, V <sub>IN</sub> =2.05V, I <sub>O</sub> =5A		<b>60</b>	<b>120</b>	mA
Adjustable Pin Current	V <sub>CTRL</sub> =2.75V, V <sub>IN</sub> =2.05V, V <sub>ADJ</sub> =0V, I <sub>O</sub> =10mA		50	<b>120</b>	μA
Thermal Resistance	TO-220-5	Junction to Case (θ <sub>JC</sub> )		3	°C/W
		Junction to Ambient (θ <sub>JA</sub> )		50	°C/W
	TO-263-5	Junction to Case (θ <sub>JC</sub> )		3	°C/W
		Junction to Ambient (θ <sub>JA</sub> )		60	°C/W

The **Bold** specifications applying to the over full operating temperature range.

Note 1: Low duty cycle pulse testing with Kelvin connections are required to order to maintain accurate data.

Note 2: Dropout voltage is defined as the minimum differential between V<sub>IN</sub> and V<sub>OUT</sub> or V<sub>CTRL</sub> and V<sub>OUT</sub> required to maintain regulation at V<sub>OUT</sub> 99% Nominal V<sub>OUT</sub>.

Note 3: V<sub>REF</sub> is measured across the Adjust pin to Sense pin.

## PIN DESCRIPTION

1. Sense = Allows Kelvin sense of  $V_{OUT}$  at the load. (Positive side of the reference voltage of the device).
2. ADJ = Negative side of the reference voltage for the device. Adding a small bypass capacitor from the ADJ pin to ground will improve the transient response.
3.  $V_{OUT}$  = Power output of the device.
4.  $V_{CTRL}$  = Supply pin for the control circuitry of the device. The current flow into this pin will be about 1% of the output current.  $V_{CTRL}$  must be between 1.0V and 1.3V greater than the output voltage for the device to regulate.
5.  $V_{IN}$  = Output load current is supplied through this pin.  $V_{IN}$  must be between 0.1V and 0.8V greater than the output voltage for the device to regulate.

## BLOCK DIAGRAM

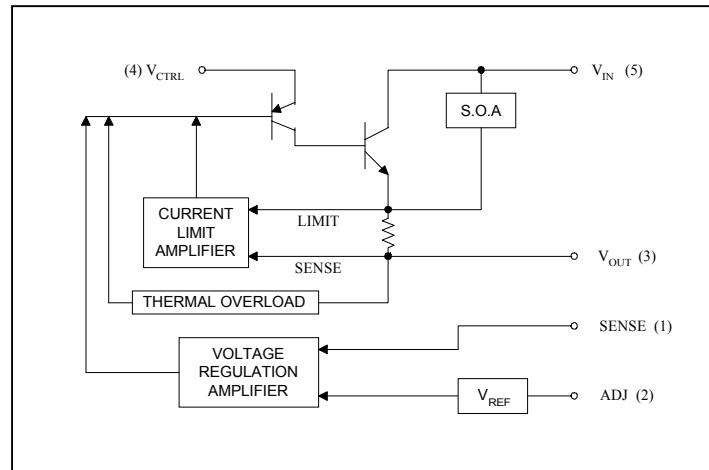

## APPLICATIONS NOTES

The SPX1581 is designed as a high performance and low cost solution for application requiring a lower dropout than traditional NPN regulators.

The SPX1581 uses a separate input voltage  $V_{CTRL}$  ( $V_{CTRL} \geq V_{OUT} + 1.3V$ ) to minimize the dropout voltage. This allows the 2.5V power for the load to come from a 3.3V system supply. As added benefit this will reduce the heat dissipation, and lower heatsink and cooling fan cost. A typical application would use 5V for  $V_{in}$  and 3.3V for  $V_{CTRL}$  from a motherboard power supply to provide a nominal 2.5V output. Using the sense pin allows to Kelvin measure the output, reducing resistive-associated errors.

The SPX1581 can power the 2.5V core voltage for microprocessors such as Pentium™, P55C™, AMD5k86™ and K6™ and the IBM PowerPC™ 603EV and 604EV processors.

\*The reduction of heat dissipation is a result of the increase of the regulator efficiency (efficiency =  $V_{OUT} / V_{IN}$ ).

### Adjustable Regulator Design

1.25V reference voltage is being developed between the SENSE pin and the ADJ pin of the SPX1581. Adding two external resistors (see fig 1.) will allow setting the output voltage from 1.25V to 6V.  $R_1$  is chosen so that this current is specified minimum load current of 10mA.  $R_2$  is given by the formula:  $V_{OUT} = V_{REF} (1 + R_2/R_1) + I_{ADJ} (R_2)$ . The current flowing from the ADJ pin is typically 50 $\mu$ A. This ADJ pin contributes to the final  $V_{OUT}$  but is usually neglected. Connecting the sense pin to the top of the resistor divider will improve load regulation.

### Lowering Noise

Using the SENSE pin to Kelvin the load will increase accuracy of the output voltage during load regulation. For the fixed voltage devices, adding a capacitor at the GND pin will improve transient response. This capacitor is chosen in the range of 1 $\mu$ F to 0.1 $\mu$ F and will depend on the amount of output capacitance in the system.

## TYPICAL APPLICATION

**Fig. 1 Adjustable Regulator**

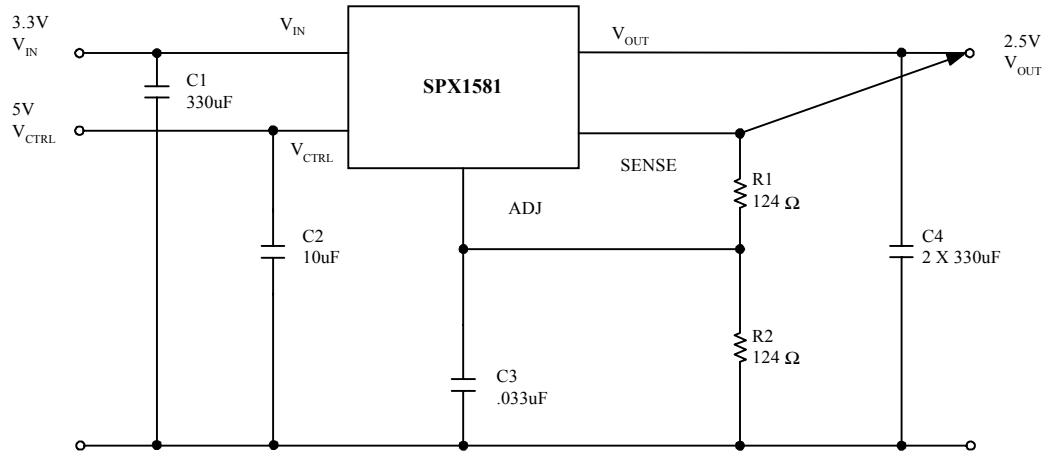

- (1)  $V_{CTRL}$  needed when  $V_{IN} < 5V$ .
- (2)  $V_{OUT} = V_{REF} (1 + R2/R1) + I_{ADJ} R2$ .
- (3)  $V_{REF}$  is measured across adjust to sense.

**Fig.2 Typical Fixed Regulator**

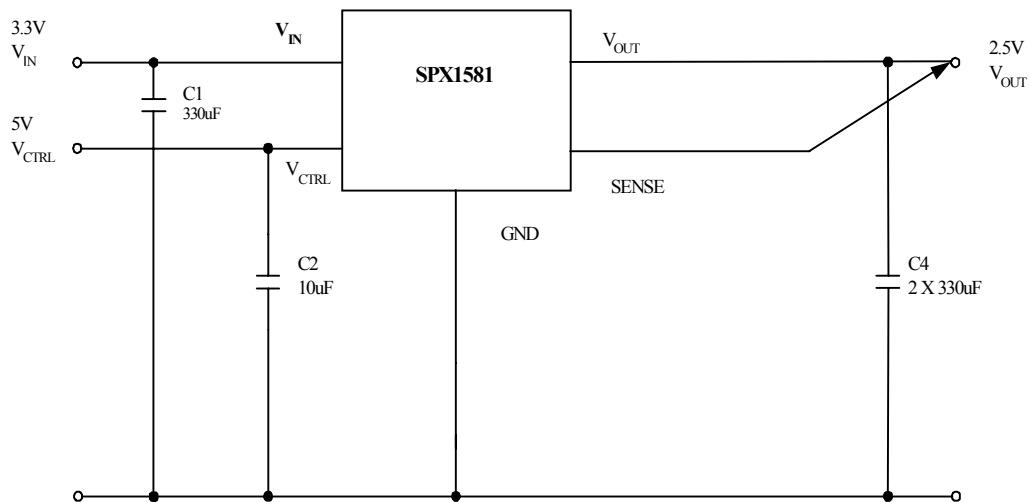

- (1)  $V_{CTRL}$  is needed when  $V_{IN} < 5V$ .

## ORDERING INFORMATION

Ordering No.	Precision	Output Voltages	Packages
SPX1581U	0.6%	Adj	3 Lead TO-220
SPX1581U-2.5	0.6%	2.5V	3 Lead TO-220
SPX1581U-2.8	0.6%	2.8V	3 Lead TO-220
SPX1581U-3.3	0.6%	3.3V	3 Lead TO-220
SPX1581T	0.6%	Adj	3 Lead TO-263
SPX1581T-2.5	0.6%	2.5V	3 Lead TO-263
SPX1581T-2.8	0.6%	2.8V	3 Lead TO-263
SPX1581T-3.3	0.6%	3.3V	3 Lead TO-263



SIGNAL PROCESSING EXCELLENCE

### Sipex Corporation

**Headquarters and Main Offices:**  
22 Linnell Circle  
Billerica, MA 01821  
TEL: (978) 667-8700  
FAX: (978) 670-9001  
e-mail: sales@sipex.com

233 South Hillview Drive  
Milpitas, CA 95035  
TEL: (408) 935-7600  
FAX: (408) 934-7500

Sipex Corporation reserves the right to make changes to any products described herein. Sipex does not assume any liability arising out of the application or use of any product or circuit described herein; neither does it convey any license under its patent rights nor the rights of others.