

GENERAL DESCRIPTION

SM5032C/D is an infrared remote control decoder utilizing COMOS technology, paired with SM5021 for transmitter. The remote control system is capable of controlling eight functions and CP1 to CP6 can multi-decode. There is an option for two toggle signal outputs in these data control functions.

Also there are two custom codes for user to separate different products.

APPLICATIONS

- * Consumer Products Remote Control
- * Toy Remote Control
- * Audio Remote Control

FEATURES

- * Wide operation voltage range, 2.4V to 6V
- * Infrared remote control receiver
- * Two custom code to separate products
- * Eight control functions for continuous signal
- * Multit-key control outputs
- * Two toggle signal can be optioned in outputs
- * A single terminal type oscillator by means of RC is provided
- * Low power consumption
- * High noise immunity
- * 14 pin DIP or SO package

PIN ASSIGNMENTS

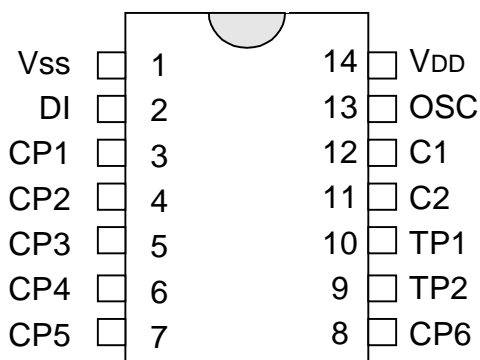

SM5032C

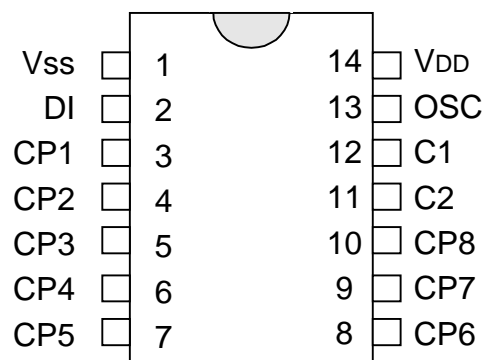

SM5032D



BLOCK DIAGRAM

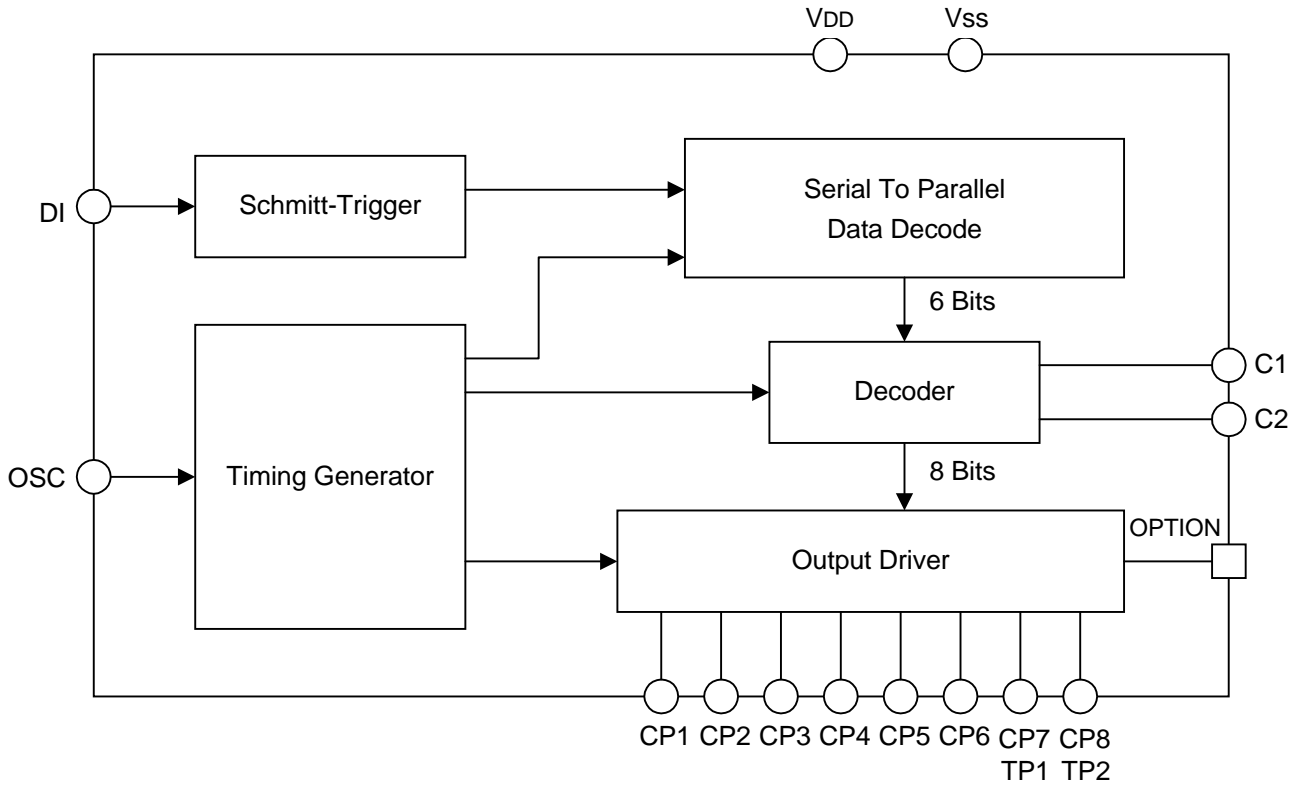

PIN DESCRIPTION

Pin Name	I/O	Function
Vss	POWER	Negative power supply
DI	I	Signal Input
CP1 ~ CP6	O	Multi-key control outputs
CP7,CP8(TP2/TP1)		Single-dey control outputs (Toggle function option)
C1,C2	I	Custom code
OSC	I	38KHz OSC pin
VDD	POWER	Positive power supply



FUNCTION DESCRIPTION

A. Decoder Signal Input Format

Bit Format

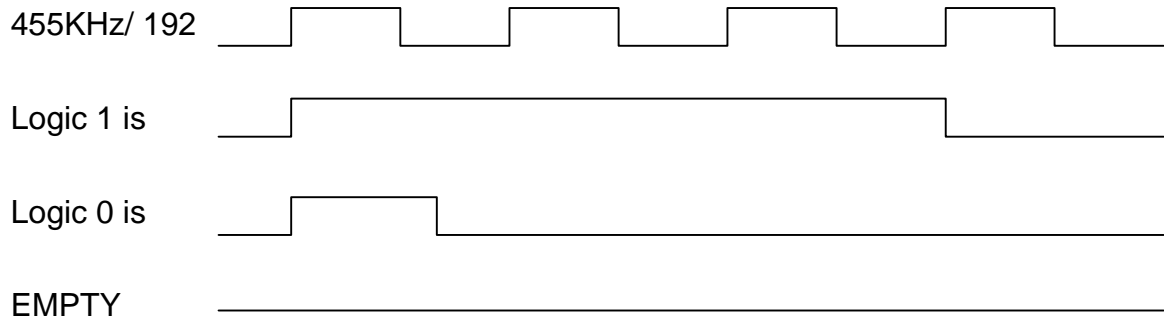

Frame Format

There are four frames, each frame contains four fields while receiving:

- a) Frame Head / Three-Bits 1 1 0 (Metal Option)
- b) Custom Code / Two-Bits C1 C2
- c) Control Word / Seven-Bits 0 0 0 0 0 1 ~ 1 0 0 0 1 1 0
- d) Synch Filed / Four-Bits of Empty

B. Receiver Code Table

Start Word	Custom Code	B1	B2	B3	B4	B5	B6	B7	Receiver
1 1 0	C1 C2	0	0	0	0	0	0	1	CP1
1 1 0	C1 C2	0	0	0	0	0	1	0	CP2
1 1 0	C1 C2	0	0	0	0	1	0	0	CP3
1 1 0	C1 C2	0	0	0	1	0	0	0	CP4
1 1 0	C1 C2	0	0	1	0	0	0	0	CP5
1 1 0	C1 C2	0	1	0	0	0	0	0	CP6
1 1 0	C1 C2	1	0	0	0	0	1	1	CP7/TP2
1 1 0	C1 C2	1	0	0	0	1	1	0	CP8/TP1



C. Receiver Waveform

Normal Condition (Paired With SM5021A)

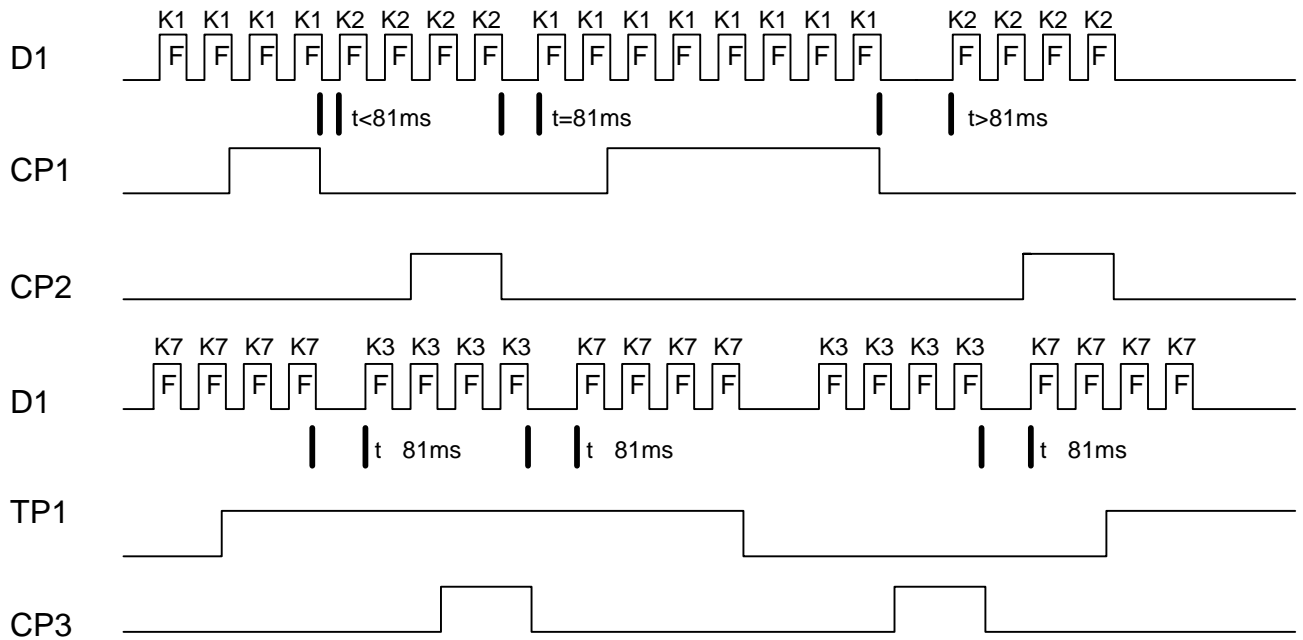

Overlap Condition (Paired With SM5021B)

If more than one data is received, multi-key decode available. (Except for CP7/CP8 or TP1/TP2)

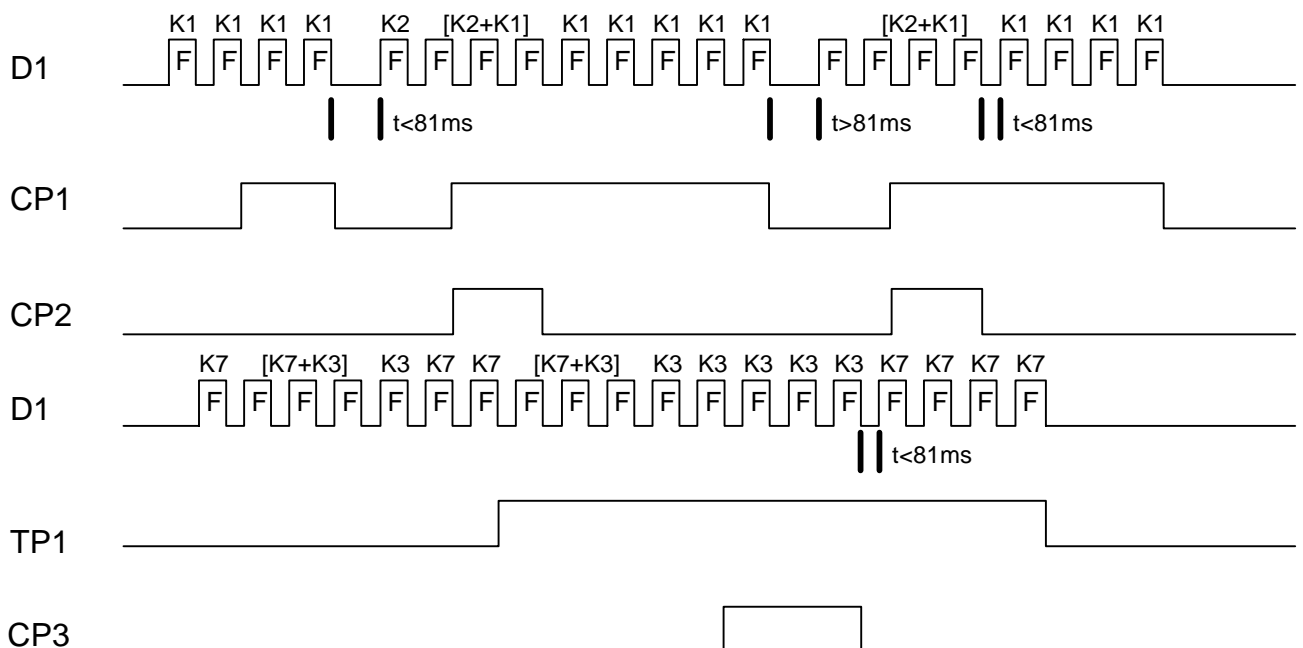



ABSOLUTE MAXIMUM RATINGS

Parameter	Symbol	Test Conditions	Parameter	Unit
Supply Voltage	VDD-Vss		-0.3 ~ 6	V
Input Voltage	VI		Vss - 0.3 ~ VDD + 0.3	V
Output Voltage	Vo		Vss - 0.3 ~ VDD + 0.3	V
Maximum Power Consumption	Pa	VDD-Vss=5V	500	mW
Operating Temperature	Topr		-10 ~ 70	
Storage Temperature	Tstg		-40 ~ 125	

DC ELECTRICAL CHARACTERISTICS

Parameter	Symbol	Test Conditions	Limits			Unit
			Min.	Typ.	Max.	
Supply Voltage	VDD		2.2	3	6	V
Stand-by Current	ISB	VDD - Vss = 3 V OSC stop all output pins open		1		μA
		OSC operation non-loading			300	
Input-high Level	VIH		1.5	2.1	3.5	V
Input Low Level	VIL		0.7	1	1.5	V
CP1 ~ CP8 Source Current	IOH	VOH = +2.4V			1	mA
CP1 ~ CP8 Sink Current	IOL	VOL = +0.8V			1	mA



APPLICATION CIRCUIT

