

Silicon Schottky Diodes

BAS 125 ...

- For low-loss, fast-recovery, meter protection, bias isolation and clamping applications
- Integrated diffused guard ring
- Low forward voltage

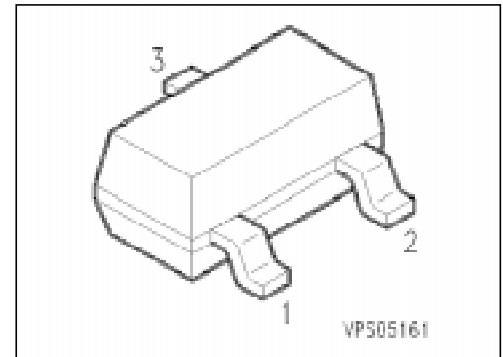

ESD: Electrostatic discharge sensitive device, observe handling precautions!

Type	Marking	Ordering Code (tape and reel)	Pin Configuration	Package ¹⁾
BAS 125	13	Q62702-D1316		SOT-23
BAS 125-04	14	Q62702-D1321		
BAS 125-05	15	Q62702-D1322		
BAS 125-06	16	Q62702-D1323		

¹⁾ For detailed information see chapter Package Outlines.

- For low-loss, fast-recovery, meter protection, bias isolation and clamping applications
- Integrated diffused guard ring
- Low forward voltage

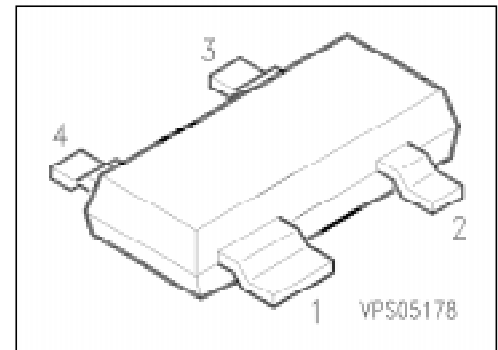

ESD: Electrostatic discharge sensitive device, observe handling precautions!

Type	Marking	Ordering Code (tape and reel)	Pin Configuration	Package ¹⁾
BAS 125-07	17	Q62702-D1327		SOT-143

Maximum Ratings per Diode

Parameter	Symbol	Values	Unit
Reverse voltage	V_R	25	V
Forward current	I_F	100	mA
Surge forward current, $t \leq 10$ ms	I_{FSM}	500	
Total power dissipation, $T_s \leq 25$ °C ³⁾	P_{tot}	250	mW
Junction temperature	T_j	150	°C
Storage temperature range	T_{stg}	- 55 ... + 150	

Thermal Resistance

Junction - ambient ²⁾	$R_{th JA}$	≤ 725	K/W
Junction - soldering point	$R_{th JS}$	≤ 565	

1) For detailed information see chapter Package Outlines.

2) Package mounted on alumina 15 mm × 16.7 mm × 0.7 mm.

3) 450 mW per package.

Electrical Characteristics per Diode
at $T_A = 25\text{ °C}$, unless otherwise specified.

Parameter	Symbol	Values			Unit
		min.	typ.	max.	
Reverse current $V_R = 20\text{ V}$ $V_R = 25\text{ V}$	I_R	– –	– –	1 10	μA
Forward voltage $I_F = 1\text{ mA}$ $I_F = 10\text{ mA}$ $I_F = 35\text{ mA}$	V_F	– – –	385 530 800	410 – 900	mV
Diode capacitance $V_R = 0, f = 1\text{ MHz}$	C_T	–	–	1.1	pF
Differential forward resistance $I_F = 5\text{ mA}, f = 10\text{ kHz}$	R_F	–	15	–	Ω

Forward current $I_F = f(V_F)$

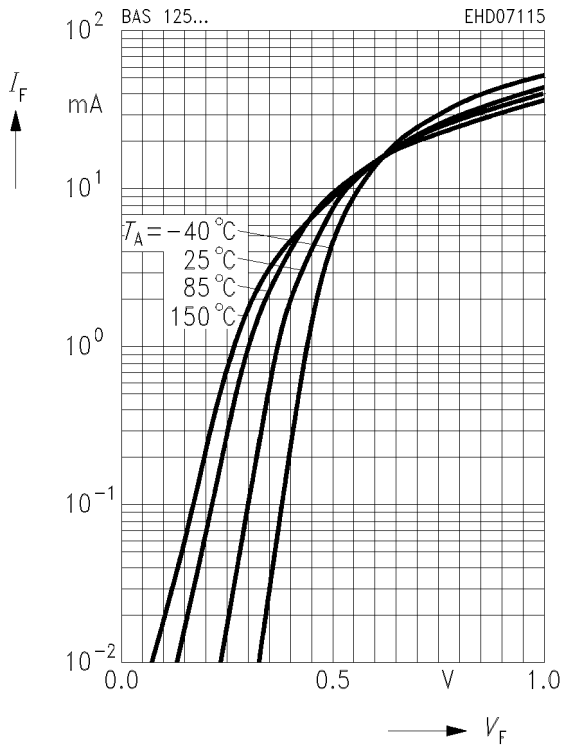

Forward current $I_F = f(T_S; T_A^*)$

*Package mounted on alumina
BAS 125-04, -05, -06, -07

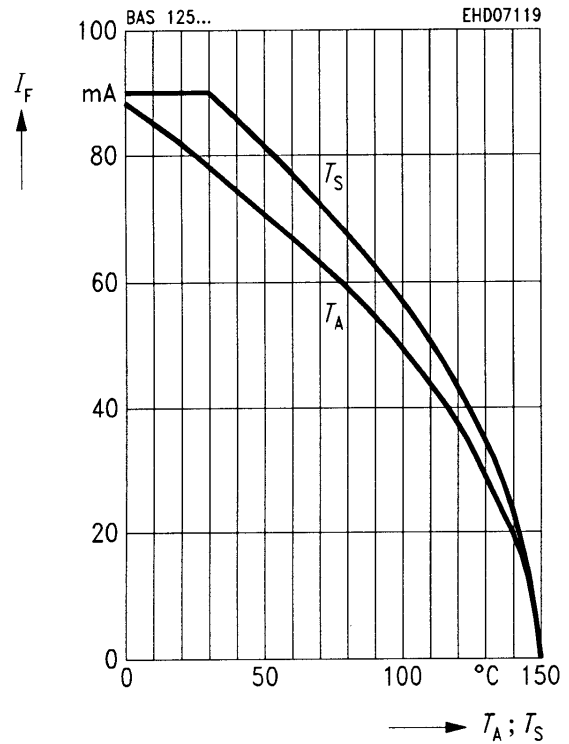

Forward current $I_F = f(T_S; T_A^*)$

*Package mounted on alumina
BAS 125

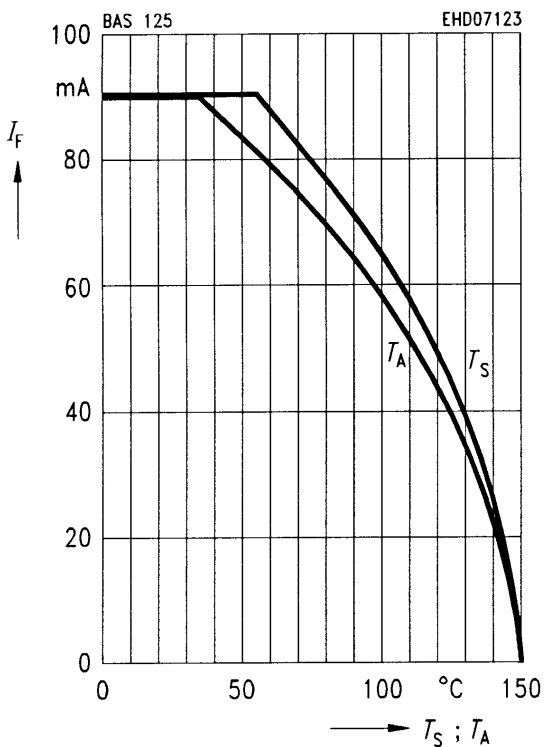

Reverse current $I_R = f(V_R)$

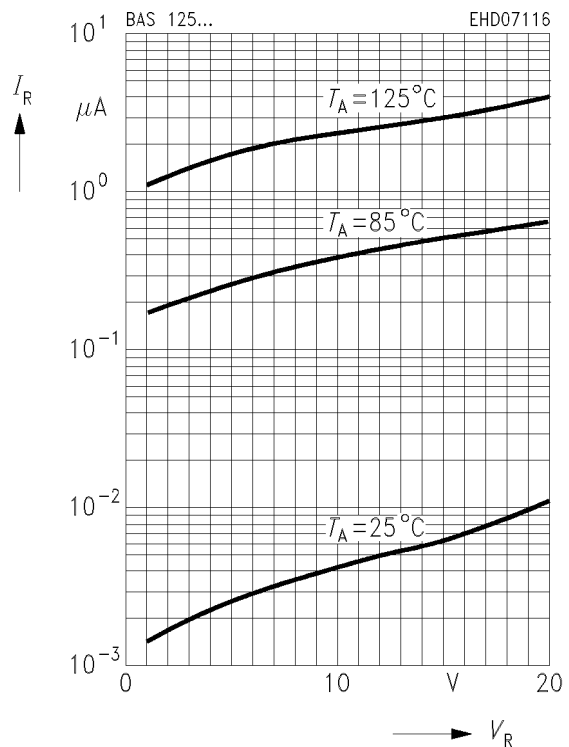

Diode capacitance $C_T = f(V_R)$
 $f = 1 \text{ MHz}$

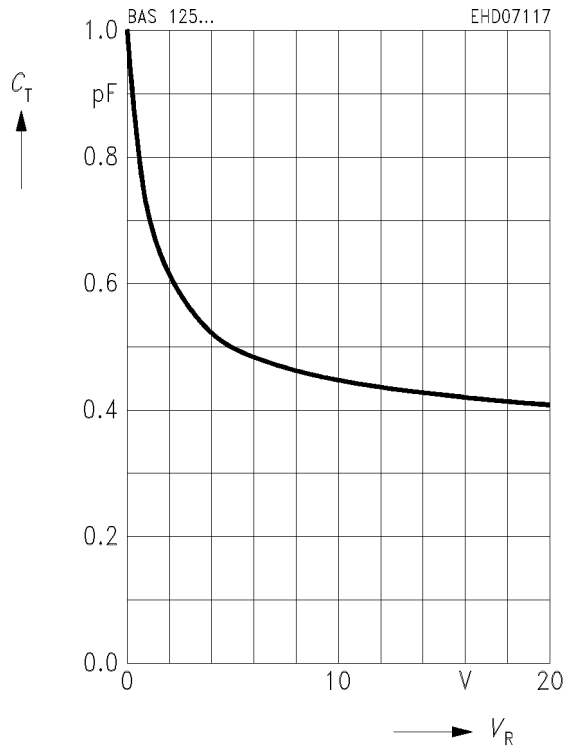

Differential forward resistance $R_F = f(I_F)$
 $f = 10 \text{ kHz}$

