

Features

- Low-power Schottky rectifier diode
- For low-loss, fast-recovery rectification, meter protection, bias isolation and clamping purposes
- Miniature plastic package for surface mounting (SMD)

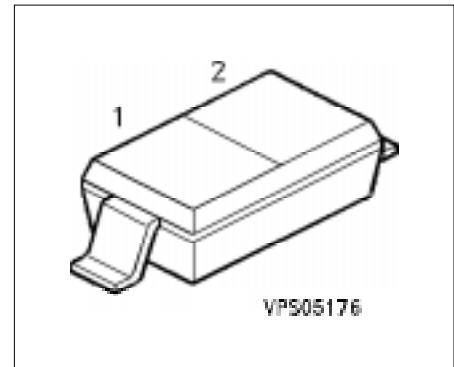

Type	Marking	Ordering Code	Pin Configuration		Package ¹⁾
			1	2	
BAT 65	White/C	Q62702-A990	C	A	SOD-123

¹⁾ Dimensions see page 313.

Maximum Ratings

Parameter	Symbol	Limit Values	Unit
Reverse voltage	V_R	40	V
Forward current	I_F	750	mA
Average forward current, $f = 50$ Hz	I_{FAV}	500	mA
Surge forward current, $t \leq 10$ ms	I_{FSM}	2.5	A
Total power dissipation, $T_S \leq 100$ °C	P_{tot}	600	mW
Junction temperature	T_j	150	°C
Storage temperature range	T_{stg}	- 55 ... + 150	°C

Thermal Resistance

Parameter	Symbol	Limit Values	Unit
Junction - soldering point	R_{thJS}	≤ 80	K/W
Junction to ambient ¹⁾	R_{thJA}	≤ 150	K/W

¹⁾ Package mounted on epoxy PCB 40 mm × 40 mm × 1.5 mm/6 cm² Cu.

Electrical Characteristics

$T_A = 25\text{ °C}$, unless otherwise specified.

Parameter	Symbol	Limit Values			Unit
		min.	typ.	max.	
Reverse current $V_R = 30\text{ V}$ $V_R = 30\text{ V}, T_A = 65\text{ °C}$	I_R	– –	– –	50 900	μA
Forward voltage $I_F = 10\text{ mA}$ $I_F = 100\text{ mA}$ $I_F = 250\text{ mA}$ $I_F = 750\text{ mA}$	V_F	– – – –	0.305 0.38 0.44 0.580	0.40 – 0.70 –	V
Diode capacitance $V_R = 10\text{ V}, f = 1\text{ MHz}$	C_T	–	8.4	12	pF

Forward Current $I_F = f(V_F)$

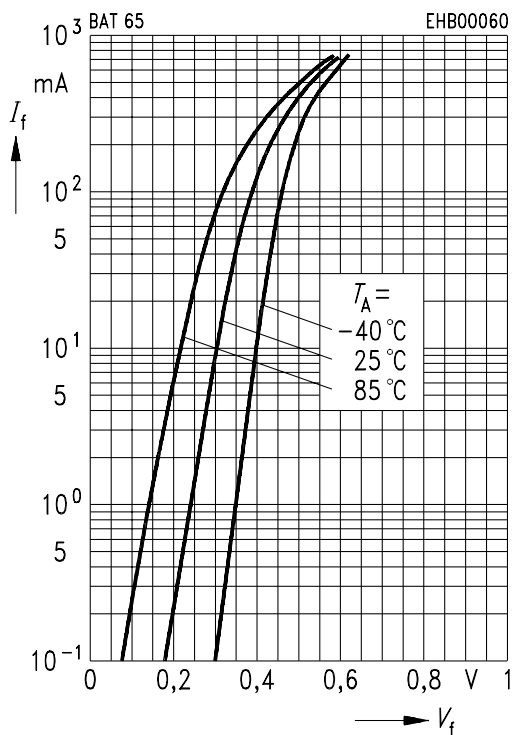

Reverse Current $I_R = f(V_R)$

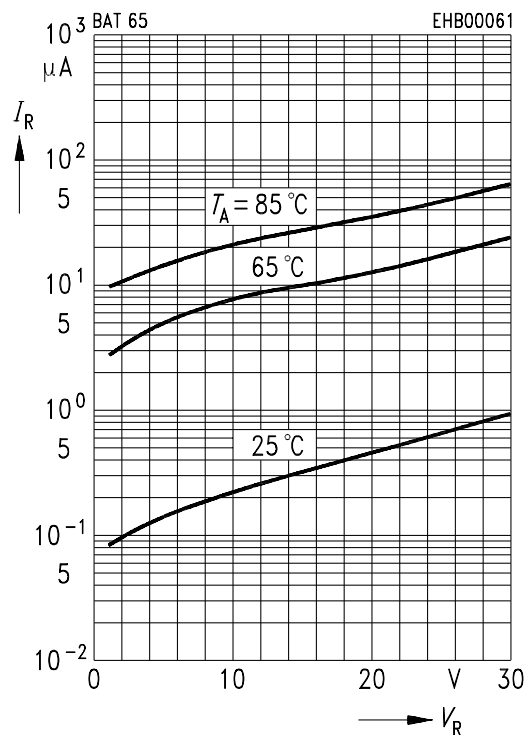

Forward Current $I_F = f(T_S; T_A^{1})$

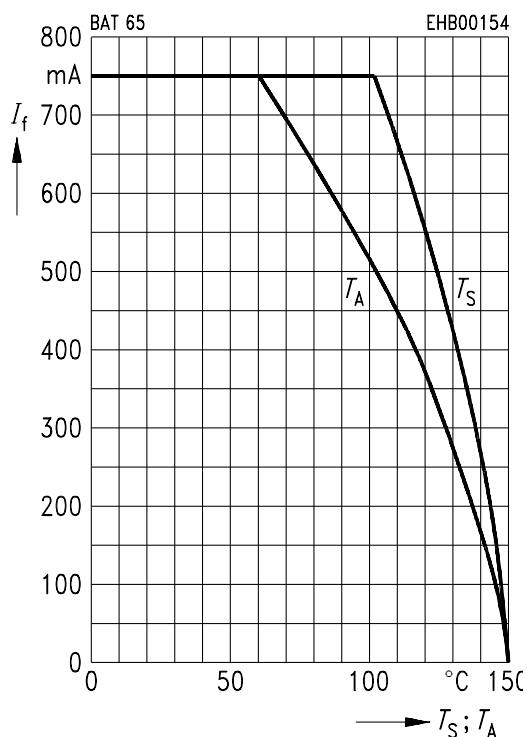

¹⁾ Package mounted on epoxy PCB $40\text{ mm} \times 40\text{ mm} \times 1.5\text{ mm}/6\text{ cm}^2\text{ Cu}$.

Permissible Load $R_{thJS} = f(t_p)$

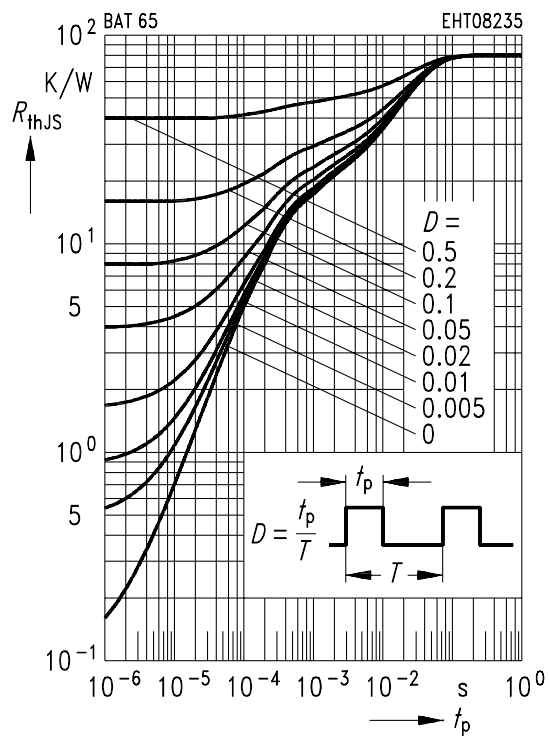

Permissible Pulse Load $I_{fmax}/I_{fDC} = f(t_p)$

