

Preliminary data

Features

- Extended frequency range up to 2.8 GHz ; special design for use in TV-sat indoor units
- High capacitance ratio

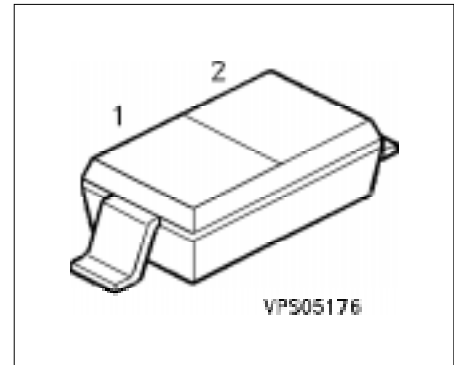

Type	Marking	Ordering Code (tape and reel)	Pin Configuration		Package
			1	2	
BB 835	yellow X	Q62702-B802	C	A	SOD-323

Maximum Ratings

Parameter	Symbol	Values	Unit
Reverse voltage	V_R	30	V
Reverse voltage ($R \geq 5 \text{ k}\Omega$)	V_{RM}	35	V
Forward current	I_F	20	mA
Operating temperature range	T_{OP}	- 55... +150	°C
Storage temperature range	T_{stg}	- 55... +150	°C

Thermal Resistance

Junction - ambient ¹⁾	$R_{th JA}$	≤ 450	K/W
----------------------------------	-------------	------------	-----

¹⁾ For detailed information see chapter Package Outline

Electrical Characteristics

at $T_A = 25\text{ °C}$, unless otherwise specified.

Parameter	Symbol	Value			Unit
		min.	typ.	max.	

DC Characteristics

Reverse current $V_R = 30\text{ V}$ $V_R = 30\text{ V}, T_A = 85\text{ °C}$	I_R	– –	– –	10 200	nA
Diode capacitance $V_R = 1\text{ V}, f = 1\text{ MHz}$ $V_R = 28\text{ V}, f = 1\text{ MHz}$	C_T	8.5 0.5	9.1 0.62	10 0.75	pF
Capacitance ratio $V_R = 1\text{ V}, 28\text{ V}, f = 1\text{ MHz}$	C_{T1}/C_{T28}	13.5	14.7	–	–
Capacitance matching $V_R = 1\dots 28\text{ V}, f = 1\text{ MHz}$	$\Delta C_T/C_T$	–	–	3	%
Series resistance $V_R = 1\text{ V}, f = 470\text{ MHz}$	r_s	–	2.4	–	Ω
Series inductance	L_s	–	1.4	–	nH

Diode capacitance $C_T = f(V_R)$

$f = 1\text{ MHz}$.

