

### FRED Diode

- Fast recovery epitaxial diode
- Soft recovery characteristics

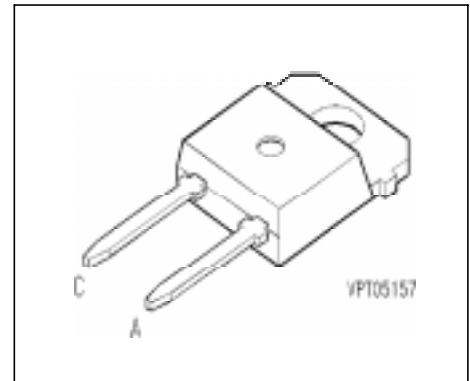

Type	$V_{RRM}$	$I_{FRMS}$	$t_{rr}$	Package	Ordering Code
BYP 300	1200V	6.5A	55ns	TO-218 AD	C67047-A2250-A2

### Maximum Ratings

Parameter	Symbol	Values	Unit
Mean forward current $T_C = 90\text{ °C}, D = 0.5$	$I_{FAV}$	4	A
RMS forward current	$I_{FRMS}$	6.5	
Surge forward current, sine halfwave, aperiodic $T_j = 100\text{ °C}, f = 50\text{ Hz}$	$I_{FSM}$	15	
Repetitive peak forward current $T_j = 100\text{ °C}, t_p \leq 10\text{ }\mu\text{s}$	$I_{FRM}$	40	
$i^2t$ value $T_j = 100\text{ °C}, t_p = 10\text{ ms}$	$\int i^2 dt$	1.1	A <sup>2</sup> s
Repetitive peak reverse voltage	$V_{RRM}$	1200	V
Surge peak reverse voltage	$V_{RSM}$	1200	
Power dissipation $T_C = 90\text{ °C}$	$P_{tot}$	15	W
Chip or operating temperature	$T_j$	-40 ... + 150	°C
Storage temperature	$T_{stg}$	-40 ... + 150	
Thermal resistance, chip case	$R_{thJC}$	$\leq 3.8$	K/W
Thermal resistance, chip-ambient	$R_{thJA}$	$\leq 46$	
DIN humidity category, DIN 40 040	-	E	-
IEC climatic category, DIN IEC 68-1	-	40 / 150 / 56	-

**Electrical Characteristics**, at  $T_j = 25\text{ °C}$ , unless otherwise specified

Parameter	Symbol	Values			Unit
		min.	typ.	max.	

**Static Characteristics**

Forward voltage drop $I_F = 4\text{ A}$ , $T_j = 25\text{ °C}$ $I_F = 4\text{ A}$ , $T_j = 100\text{ °C}$	$V_F$	- -	2.3 2	3 -	V
Reverse current $V_R = 1200\text{ V}$ , $T_j = 25\text{ °C}$ $V_R = 1200\text{ V}$ , $T_j = 100\text{ °C}$ $V_R = 1200\text{ V}$ , $T_j = 150\text{ °C}$	$I_R$	- - -	0.01 0.05 0.15	0.25 - -	mA

**AC Characteristics**

Reverse recovery charge $I_F = 4\text{ A}$ , $V_{CC} = 300\text{ V}$ , $di_F/dt = -800\text{ A}/\mu\text{s}$ $T_j = 100\text{ °C}$	$Q_{rr}$	-	0.8	-	$\mu\text{C}$
Peak reverse recovery current $I_F = 4\text{ A}$ , $V_{CC} = 300\text{ V}$ , $di_F/dt = -800\text{ A}/\mu\text{s}$ $T_j = 100\text{ °C}$	$I_{RRM}$	-	22	-	A
Reverse recovery time $I_F = 4\text{ A}$ , $V_{CC} = 300\text{ V}$ , $di_F/dt = -800\text{ A}/\mu\text{s}$ $T_j = 100\text{ °C}$	$t_{rr}$	-	55	-	ns
Storage time $I_F = 4\text{ A}$ , $V_{CC} = 300\text{ V}$ , $di_F/dt = -800\text{ A}/\mu\text{s}$ $T_j = 100\text{ °C}$	$t_S$	-	30	-	
Softfaktor $I_F = 4\text{ A}$ , $V_{CC} = 300\text{ V}$ , $di_F/dt = -800\text{ A}/\mu\text{s}$ $T_j = 100\text{ °C}$	S	-	0.8	-	-