

16M x 4-Bit Dynamic RAM (4k & 8k Refresh)

HYB 3164400AJ/AT(L) -40/-50/-60
HYB 3165400AJ/AT(L) -40/-50/-60

Advanced Information

- 16 777 216 words by 4-bit organization
- 0 to 70 °C operating temperature
- Fast Page Mode operation
- Performance:

		-40	-50	-60	
t _{RAC}	$\overline{\text{RAS}}$ access time	40	50	60	ns
t _{CAC}	$\overline{\text{CAS}}$ access time	10	13	15	ns
t _{AA}	Access time from address	20	25	30	ns
t _{RC}	Read/write cycle time	75	90	110	ns
t _{PC}	Fast page mode cycle time	30	35	40	ns

- Single + 3.3 V ($\pm 0.3V$) power supply
- Low power dissipation:
 - max. 396 mW active (HYB 3164400AJ/AT(L) -40)
 - max. 324 mW active (HYB 3164400AJ/AT(L) -50)
 - max. 270 mW active (HYB 3164400AJ/AT(L) -60)
 - max. 558 mW active (HYB 3165400AJ/AT(L) -40)
 - max. 468 mW active (HYB 3165400AJ/AT(L) -50)
 - max. 378 mW active (HYB 3165400AJ/AT(L) -60)
 - 7.2 mW standby (LVTTL)
 - 3.24 mW standby (LVCMOS)
 - 720 μ W standby for L-versions
- Read, write, read-modify-write, $\overline{\text{CAS}}$ -before- $\overline{\text{RAS}}$ refresh (CBR), $\overline{\text{RAS}}$ -only refresh, hidden refresh and self refresh (L-version only)
- 8192 refresh cycles/128 ms , 13 R/ 11C addresses (HYB 3164400AJ/AT)
- 4096 refresh cycles/ 64 ms , 12 R/ 12C addresses (HYB 3165400AJ/AT)
- 256 msec refresh period for L-versions
- Plastic Package

P-SOJ-32-1	400 mil	HYB 3164(5)400AJ
P-TSOPII-32-1	400 mil	HYB 3164(5)400AT

This device is a 64 MBit dynamic RAM organized 16 777 216 by 4 bits. The device is fabricated on an advanced second generation 64Mbit 0,35 μm -CMOS silicon gate process technology. The circuit and process design allow this device to achieve high performance and low power dissipation. This DRAM operates with a single 3.3 +/-0.3V power supply and interfaces with either LVTTTL or LVCMOS levels. Multiplexed address inputs permit the HYB 3164(5)400AJ/AT to be packaged in a 400mil wide SOJ-32 or TSOP-32 plastic package. These packages provide high system bit densities and are compatible with commonly used automatic testing and insertion equipment. The HYB3164(5)400ATL parts (L-versions) have a very low power „sleep mode“ supported by Self Refresh

Ordering Information

Type	Ordering Code	Package	Descriptions
HYB 3164400AJ-40		P-SOJ-32-1 400 mil	DRAM (access time 40 ns)
HYB 3164400AJ-50		P-SOJ-32-1 400 mil	DRAM (access time 50 ns)
HYB 3164400AJ-60		P-SOJ-32-1 400 mil	DRAM (access time 60 ns)
HYB 3164400AT-40		P-TSOPII-32-1 400 mil	DRAM (access time 40 ns)
HYB 3164400AT-50		P-TSOPII-32-1 400 mil	DRAM (access time 50 ns)
HYB 3164400AT-60		P-TSOPII-32-1 400 mil	DRAM (access time 60 ns)
HYB 3165400AJ-40		P-SOJ-32-1 400 mil	DRAM (access time 40 ns)
HYB 3165400AJ-50		P-SOJ-32-1 400 mil	DRAM (access time 50 ns)
HYB 3165400AJ-60		P-SOJ-32-1 400 mil	DRAM (access time 60 ns)
HYB 3165400AT-40		P-TSOPII-32-1 400 mil	DRAM (access time 40 ns)
HYB 3165400AT-50		P-TSOPII-32-1 400 mil	DRAM (access time 50 ns)
HYB 3165400AT-60		P-TSOPII-32-1 400 mil	DRAM (access time 60 ns)
HYB 3164(5)400ATL		P-TSOPII-32-1 400 mil	Low Power DRAMs

Pin Names

A0-A12	Address Inputs for 8k-refresh versions HYB 3164400AJ/AT(L)
A0-A11	Address Inputs for 4k-refresh versions HYB 3165400AJ/AT(L)
$\overline{\text{RAS}}$	Row Address Strobe
$\overline{\text{OE}}$	Output Enable
I/O1-I/O4	Data Input/Output
$\overline{\text{CAS}}$	Column Address Strobe
$\overline{\text{WE}}$	Read/Write Input
Vcc	Power Supply (+ 3.3V)
Vss	Ground

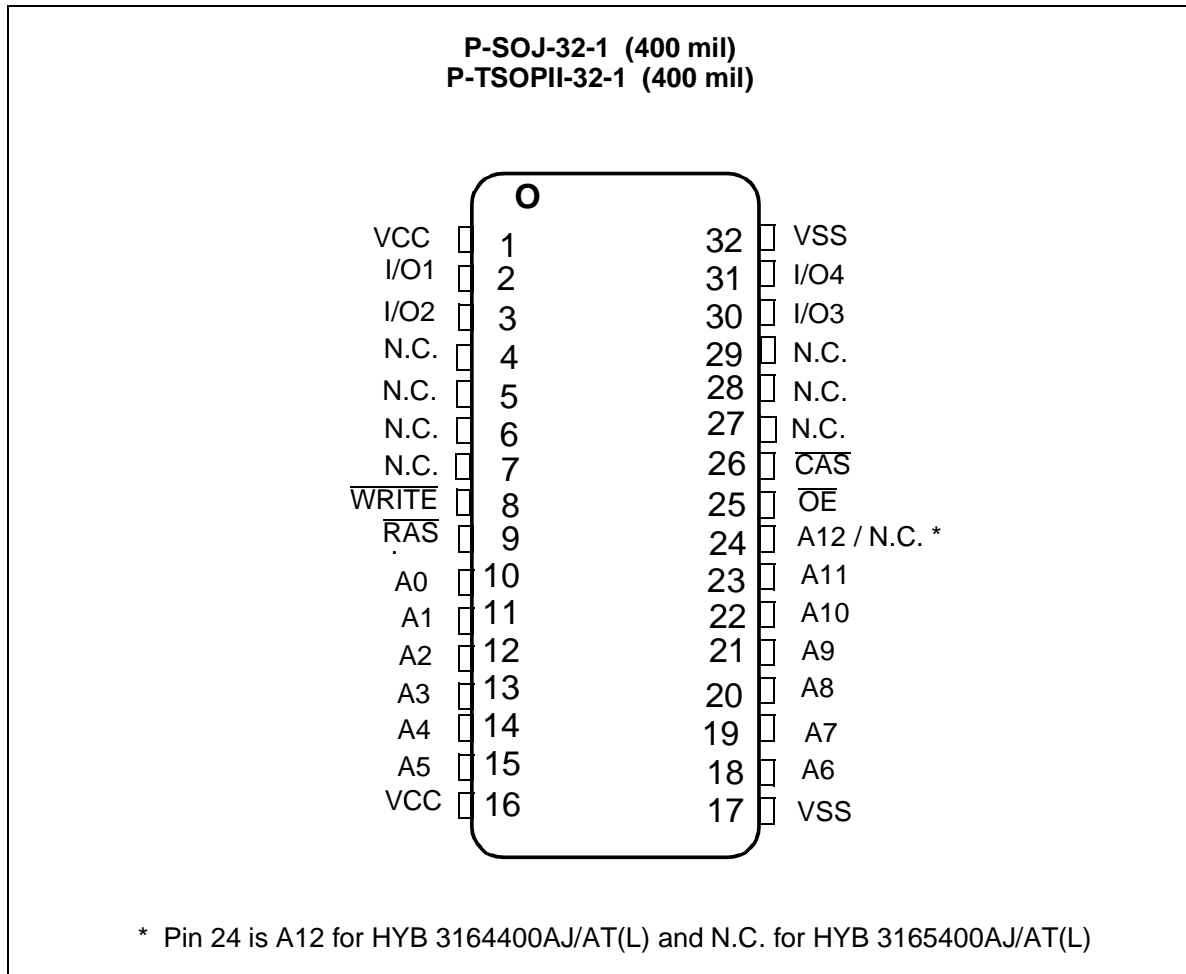

Pin Configuration

TRUTH TABLE

FUNCTION		RAS	CAS	WE	OE	ROW ADDR	COL ADDR	I/O1-I/O4
Standby		H	H - X	X	X	X	X	High Impedance
Read		L	L	H	L	ROW	COL	Data Out
Early-Write		L	L	L	X	ROW	COL	Data In
Delayed-Write		L	L	H - L	H	ROW	COL	Data In
Read-Modify-Write		L	L	H - L	L - H	ROW	COL	Data Out, Data In
Fast Page Mode Read	1st Cycle	L	H - L	H	L	ROW	COL	Data Out
	2nd Cycle	L	H - L	H	L	n/a	COL	Data Out
Fast Page Mode Early Write	1st Cycle	L	H - L	L	X	ROW	COL	Data In
	2nd Cycle	L	H - L	L	X	n/a	COL	Data In
Fast Page Mode RMW	1st Cycle	L	H - L	H - L	L - H	ROW	COL	Data Out, Data In
	2st Cycle	L	H - L	H - L	L - H	n/a	COL	Data Out, Data In
RAS only refresh		L	H	X	X	ROW	n/a	High Impedance
CAS-before-RAS refresh		H - L	L	H	X	X	n/a	High Impedance
Test Mode Entry		H - L	L	L	X	X	n/a	High Impedance
Hidden Refresh	READ	L-H-L	L	H	L	ROW	COL	Data Out
	WRITE	L-H-L	L	L	X	ROW	COL	Data In

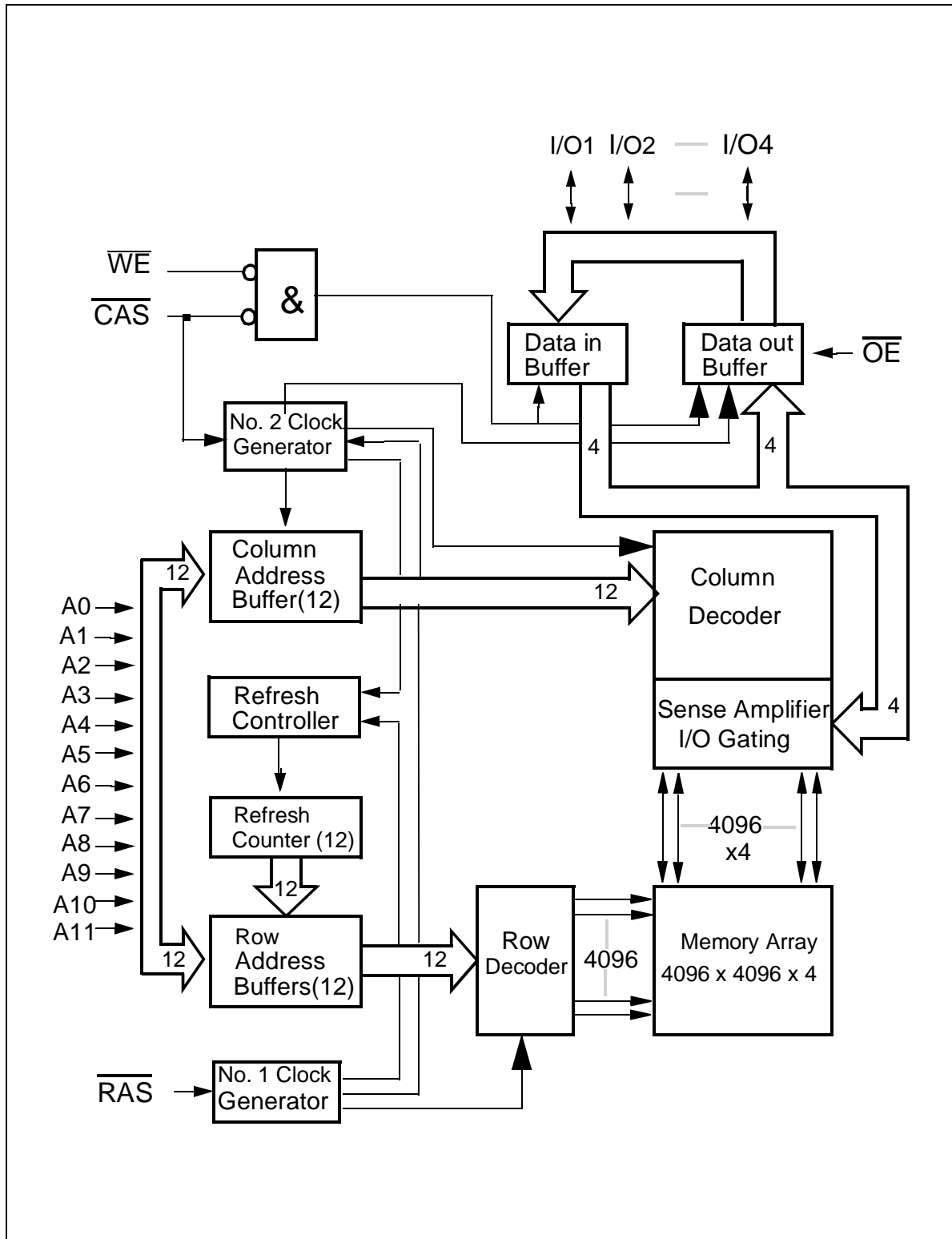

Block Diagram for HYB 3165400AJ/AT(L)

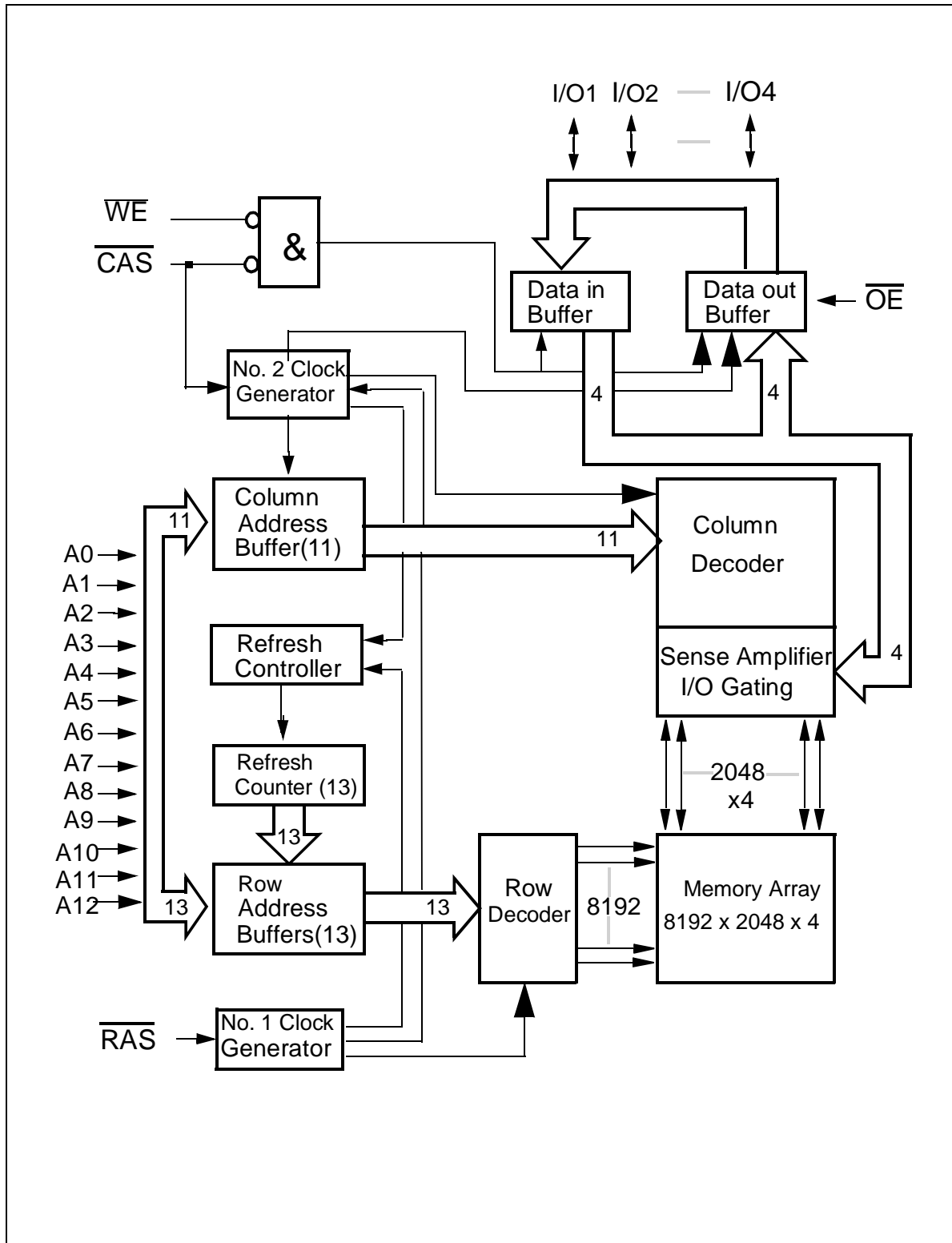

Block Diagram for HYB 3164400AJ/AT(L)

Absolute Maximum Ratings

Operating temperature range.....	0 to 70 °C
Storage temperature range.....	- 55 to 150 °C
Input/output voltage.....	-0.5 to min (V _{CC} +0.5,4.6) V
Power supply voltage.....	-0.5V to 4.6 V
Power dissipation.....	1.0 W
Data out current (short circuit).....	50 mA

Note

Stresses above those listed under „Absolute Maximum Ratings“ may cause permanent damage of the device. Exposure to absolute maximum rating conditions for extended periods may effect device reliability.

DC Characteristics

T_A = 0 to 70 °C, V_{SS} = 0 V, V_{CC} = 3.3 V ± 0.3 V

Parameter	Symbol	Limit Values		Unit	Note
		min.	max.		
Input high voltage	V _{IH}	2.0	V _{CC} +0.3	V	1)
Input low voltage	V _{IL}	- 0.3	0.8	V	1)
Output high voltage (LVTTL) Output „H“ level voltage (I _{out} = -2mA)	V _{OH}	2.4	-	V	
Output low voltage (LVTTL) Output „L“ level voltage (I _{out} = +2mA)	V _{OL}	-	0.4	V	
Output high voltage (LVCMOS) Output „H“ level voltage (I _{out} = -100uA)	V _{OH}	V _{CC} -0.2	-	V	
Output low voltage (LVCMOS) Output „L“ level voltage (I _{out} = +100uA)	V _{OL}	-	0.2	V	
Input leakage current,any input (0 V < V _{in} < V _{CC} , all other pins = 0 V)	I _{I(L)}	- 2	2	μA	
Output leakage current (DO is disabled, 0 V < V _{out} < V _{CC})	I _{O(L)}	- 2	2	μA	

DC-Characteristics (cont'd)

$T_A = 0$ to 70 °C, $V_{SS} = 0$ V, $V_{CC} = 3.3$ V \pm 0.3 V

Parameter	Symbol	refresh version		Unit	Note
		4k	8k		
Operating Current -40 ns version -50 ns version -60 ns version (\overline{RAS} , \overline{CAS} , address cycling: tRC = tRC min.)	I_{CC1}	155 130 105	110 90 75	mA mA mA	2) 3) 4)
Standby Current ($\overline{RAS}=\overline{CAS}=V_{ih}$)	I_{CC2}	2	2	mA	–
\overline{RAS} Only Refresh Current: -40 ns version -50 ns version -60 ns version (RAS cycling: CAS = VIH: tRC = tRC min.)	I_{CC3}	155 130 105	110 90 75	mA mA mA	2) 4)
Fast Page Mode Current: -40 ns version -50 ns version -60 ns version ($\overline{RAS} = V_{IL}$, \overline{CAS} , address cycling: tPC=tPC min.)	I_{CC4}	70 60 50	70 60 50	mA mA mA	2) 3) 4)
Standby Current ($\overline{RAS}=\overline{CAS}=V_{cc}-0.2V$)	I_{CC5}	900	900	μ A	–
Standby Current (L-Version) ($\overline{RAS}=\overline{CAS}=V_{cc}-0.2V$)	I_{CC5}	200	200	μ A	–
\overline{CAS} Before \overline{RAS} Refresh Current -40 ns version -50 ns version -60 ns version (\overline{RAS} , \overline{CAS} cycling: tRC = tRC min.)	I_{CC6}	155 130 105	155 130 105	mA mA mA	2) 4)
Self Refresh Current (L-version only) (CBR cycle with tRAS>TRASSmin, \overline{CAS} held low, $\overline{WE} = V_{cc}-0.2V$, Address and Din= $V_{cc}-0.2V$ or 0.2V)	I_{CC7}	400	400	μ A	

AC Characteristics (note: 6,7,8)

AC64-2F

$T_A = 0 \text{ to } 70 \text{ }^\circ\text{C}$, $V_{CC} = 3.3 \pm 0.3\text{V}$

Parameter	Symbol	-40		-50		-60		Unit	Note
		min.	max.	min.	max.	min.	max.		
Common Parameters									
Random read or write cycle time	t_{RC}	75	–	90	–	110	–	ns	
$\overline{\text{RAS}}$ pulse width	t_{RAS}	40	100k	50	100k	60	100k	ns	
$\overline{\text{CAS}}$ pulse width	t_{CAS}	10	100k	13	100k	15	100k	ns	
$\overline{\text{RAS}}$ precharge time	t_{RP}	25	–	30	–	40	–	ns	
$\overline{\text{CAS}}$ precharge time	t_{CP}	10	–	10	–	10	–	ns	
Row address setup time	t_{ASR}	0	–	0	–	0	–	ns	
Row address hold time	t_{RAH}	5	–	7	–	10	–	ns	
Column address setup time	t_{ASC}	0	–	0	–	0	–	ns	
Column address hold time	t_{CAH}	5	–	7	–	10	–	ns	
$\overline{\text{RAS}}$ to $\overline{\text{CAS}}$ delay time	t_{RCD}	15	30	17	37	20	45	ns	
$\overline{\text{RAS}}$ to column address delay	t_{RAD}	10	20	12	25	15	30	ns	
$\overline{\text{RAS}}$ hold time	t_{RSH}	10	–	13	–	15	–	ns	
$\overline{\text{CAS}}$ hold time	t_{CSH}	40	–	50	–	60	–	ns	
$\overline{\text{CAS}}$ to $\overline{\text{RAS}}$ precharge time	t_{CRP}	5	–	5	–	5	–	ns	
Transition time (rise and fall)	t_T	1	30	1	30	1	30	ns	7
Refresh period for 8k-refresh	t_{REF}	–	128	–	128	–	128	ms	
Refresh period for 4k-refresh	t_{REF}	–	64	–	64	–	64	ms	
Refresh period for L-versions	t_{REF}	–	256	–	256	–	256	ms	

Read Cycle

Access time from $\overline{\text{RAS}}$	t_{RAC}	–	40	–	50	–	60	ns	8, 9
Access time from $\overline{\text{CAS}}$	t_{CAC}	–	10	–	13	–	15	ns	8, 9
Access time from column address	t_{AA}	–	20	–	25	–	30	ns	8, 10
$\overline{\text{OE}}$ access time	t_{OEA}	–	10	–	13	–	15	ns	8
Column address to $\overline{\text{RAS}}$ lead time	t_{RAL}	20	–	25	–	30	–	ns	
Read command setup time	t_{RCS}	0	–	0	–	0	–	ns	
Read command hold time	t_{RCH}	0	–	0	–	0	–	ns	11
Read command hold time referenced to $\overline{\text{RAS}}$	t_{RRH}	0	–	0	–	0	–	ns	11
$\overline{\text{CAS}}$ to output in low-Z	t_{CLZ}	0	–	0	–	0	–	ns	8

AC Characteristics (cont'd)(note: 6,7,8)

AC64-2F

$T_A = 0$ to 70 °C, $V_{CC} = 3.3 \pm 0.3V$

Parameter	Symbol	-40		-50		-60		Unit	Note
		min.	max.	min.	max.	min.	max.		
Output buffer turn-off delay	t_{OFF}	–	10	–	13	–	15	ns	12
Output buffer turn-off delay from \overline{OE}	t_{OEZ}	–	10	–	13	–	15	ns	12
Data to \overline{OE} low delay	t_{DZO}	0	–	0	–	0	–	ns	13
\overline{CAS} high to data delay	t_{CDD}	10	–	13	–	15	–	ns	14
\overline{OE} high to data delay	t_{ODD}	10	–	13	–	15	–	ns	14

Write Cycle

Write command hold time	t_{WCH}	5	–	7	–	10	–	ns	
Write command pulse width	t_{WP}	5	–	7	–	10	–	ns	
Write command setup time	t_{WCS}	0	–	0	–	0	–	ns	15
Write command to \overline{RAS} lead time	t_{RWL}	10	–	13	–	15	–	ns	
Write command to \overline{CAS} lead time	t_{CWL}	10	–	13	–	15	–	ns	
Data setup time	t_{DS}	0	–	0	–	0	–	ns	16
Data hold time	t_{DH}	5	–	7	–	10	–	ns	16
\overline{CAS} delay time from Din	t_{DZC}	0	–	0	–	0	–	ns	13

Read-Modify-Write Cycle

Read-write cycle time	t_{RWC}	105	–	126	–	150	–	ns	
\overline{RAS} to \overline{WE} delay time	t_{RWD}	55	–	68	–	80	–	ns	15
\overline{CAS} to \overline{WE} delay time	t_{CWD}	25	–	31	–	35	–	ns	15
Column address to \overline{WE} delay time	t_{AWD}	35	–	43	–	50	–	ns	15
\overline{OE} command hold time	t_{OEH}	5	–	7	–	10	–	ns	

Fast Page Mode Cycle

Fast page mode cycle time	t_{PC}	30	–	35	–	40	–	ns	
Access time from \overline{CAS} precharge	t_{CPA}	–	25	–	30	–	35	ns	8
\overline{RAS} pulse width	t_{RAS}	40	200k	50	200k	60	200k	ns	
\overline{CAS} precharge to \overline{RAS} Delay	t_{RHPC}	25	–	30	–	35	–	ns	

AC Characteristics (cont'd)(note: 6,7,8)

AC64-2F

$T_A = 0$ to 70 °C, $V_{CC} = 3.3 \pm 0.3V$

Parameter	Symbol	-40		-50		-60		Unit	Note
		min.	max.	min.	max.	min.	max.		

Fast Page Mode Read-Modify-Write Cycle

Fast page mode read-write cycle time	t_{PRWC}	60	–	71	–	80	–	ns	
\overline{CAS} precharge to \overline{WE}	t_{CPWD}	40	–	48	–	55	–	ns	

\overline{CAS} -before- \overline{RAS} Refresh Cycle

\overline{CAS} setup time	t_{CSR}	5	–	5	–	5	–	ns	
\overline{CAS} hold time	t_{CHR}	5	–	5	–	10	–	ns	
\overline{RAS} to \overline{CAS} precharge time	t_{RPC}	0	–	0	–	0	–	ns	
Write to \overline{RAS} precharge time	t_{WRP}	5	–	5	–	10	–	ns	
Write hold time referenced to \overline{RAS}	t_{WRH}	5	–	5	–	10	–	ns	

Self Refresh Cycle (L-version only)

\overline{RAS} pulse width	t_{RASS}	100k	–	100k	–	100k	–	ns	17
\overline{RAS} precharge time	t_{RPS}	75	–	90	–	110	–	ns	17
\overline{CAS} hold time	t_{CHS}	-50	–	-50	–	-50	–	ns	17

Test Mode Cycle

Write command setup time	t_{WTS}	5	–	5	–	5	–	ns	18
Write command hold time	t_{WTH}	5	–	5	–	5	–	ns	18

Capacitance

$T_A = 0$ to 70 °C, $V_{CC} = 3.3 V \pm 0.3 V$, $f = 1$ MHz

Parameter	Symbol	Limit Values		Unit
		min.	max.	
Input capacitance (A0 to A11,A12)	C_{I1}	–	5	pF
Input capacitance (\overline{RAS} , \overline{CAS} , \overline{WE} , \overline{OE})	C_{I2}	–	7	pF
I/O capacitance (I/O1-I/O4)	C_{I0}	–	7	pF

Notes:

- 1) All voltages are referenced to VSS.
Vih may overshoot to Vcc + 2.0 V for pulse widths of < 4ns with 3.3V. Vil may undershoot to -2.0V for pulse width < 4.0 ns with 3.3V. Pulse width measured at 50% points with amplitude measured peak to DC reference.
- 2) ICC1, ICC3, ICC4 and ICC6 and ICC7 depend on cycle rate.
- 3) ICC1 and ICC4 depend on output loading. Specified values are measured with the output open.
- 4) Address can be changed once or less while $\overline{RAS} = Vil$. In the case of ICC4 it can be changed once or less during a fast page mode cycle (tpc).
- 5) An initial pause of 100 μ s is required after power-up followed by 8 \overline{RAS} -only-refresh cycles, before proper device operation is achieved. In case of using internal refresh counter, a minimum of 8 \overline{CAS} -before- \overline{RAS} initialization cycles instead of 8 \overline{RAS} cycles are required.
- 6) AC measurements assume tT = 5 ns.
- 7) VIH (min.) and VIL (max.) are reference levels for measuring timing of input signals. Also, transition times are measured between VIH and VIL.
- 8) Measured with the specified current load and 100 pF at Voh = 2.0 V and Vol = 0.8 V.
- 9) Operation within the tRCD (max.) limit ensures that tRAC (max.) can be met. tRCD (max.) is specified as a reference point only: If tRCD is greater than the specified tRCD (max.) limit, then access time is controlled by tCAC.
- 10) Operation within the tRAD (max.) limit ensures that tRAC (max.) can be met. tRAD (max.) is specified as a reference point only: If tRAD is greater than the specified tRAD (max.) limit, then access time is controlled by tAA.
- 11) Either tRCH or tRRH must be satisfied for a read cycle.
- 12) tOFF (max.) and tOEZ (max.) define the time at which the outputs achieve the open-circuit condition and are not referenced to output voltage levels.
- 13) Either tDZC or tDZO must be satisfied.
- 14) Either tCDD or tODD must be satisfied.
- 15) tWCS, tRWD, tCWD, tAWD and tCPWD are not restrictive operating parameters. They are included in the data sheet as electrical characteristics only. If tWCS > tWCS (min.), the cycle is an early write cycle and the I/O pin will remain open-circuit (high impedance) through the entire cycle; if tRWD > tRWD (min.), tCWD > tCWD (min.), tAWD > tAWD (min.) and tCPWD > tCPWD (min.) , the cycle is a read-write cycle and I/O pins will contain data read from the selected cells. If neither of the above sets of conditions is satisfied, the condition of the I/O pins (at access time) is indeterminate.
- 16) These parameters are referenced to \overline{CAS} leading edge in early write cycles and to \overline{WRITE} leading edge in Read-Modify-Write cycles.
- 17) When using Self Refresh mode, the following refresh operations must be performed to ensure proper DRAM operation:
If row addresses are being refresh in an evenly distributed manner over the refresh interval using CBR refresh cycles, then only one CBR cycle must be performed immediately after exit from Self Refresh.
If row addresses are being refresh in any other manner (ROR - Distributed/Burst or CBR-Burst) over the refresh interval, then a full set of row refreshed must be performed immediately before entry to and immediately after exit from Self Refresh.
- 18) In a Test Mode Read Cycle, the value of trac, taa, tcac and tcpa are delayed by 5 ns from the specified value. These parameters must be adjusted in Test Mode cycles by adding 5ns to the specified value. Associated timings must be adjusted by 5 ns.

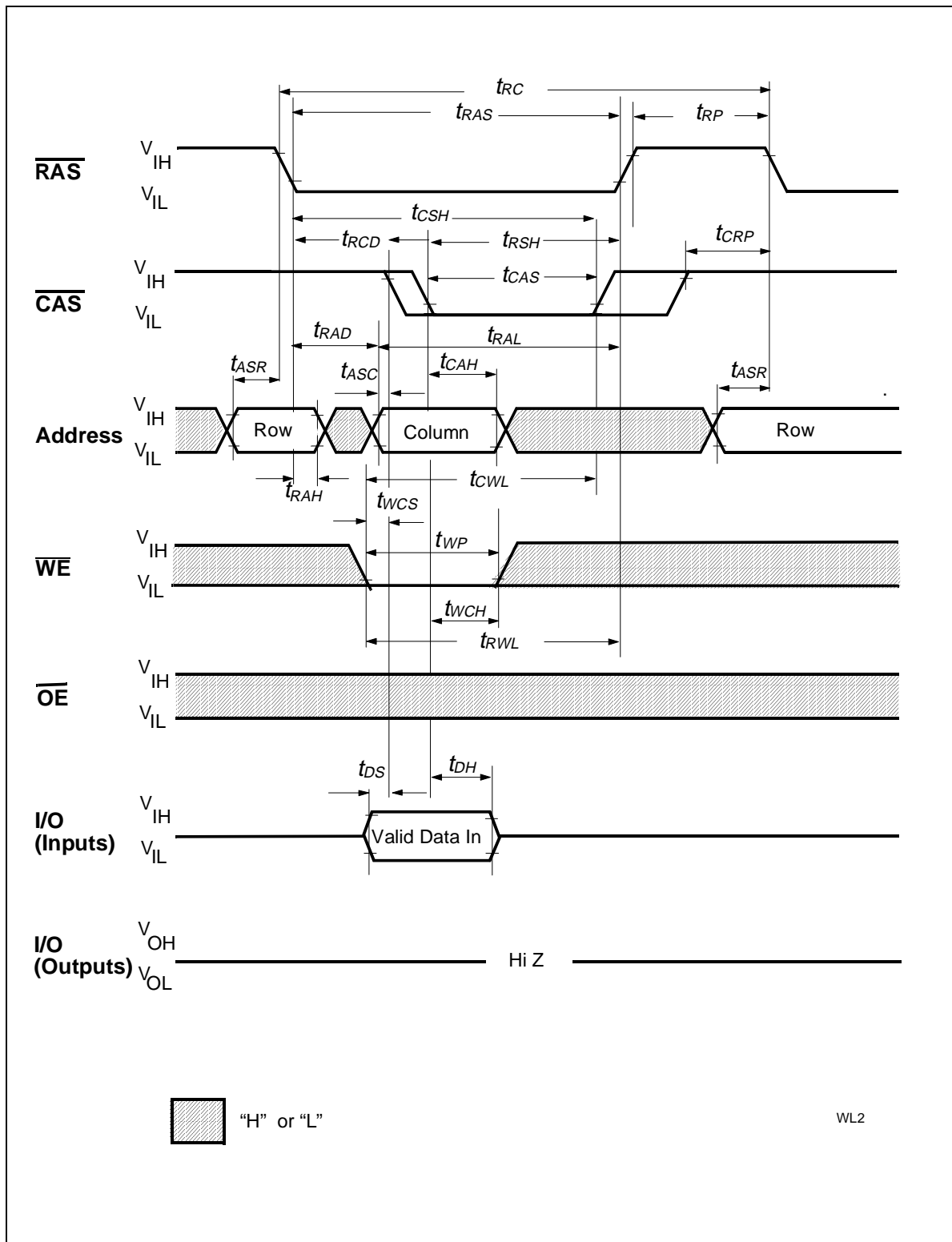

Write Cycle (Early Write)

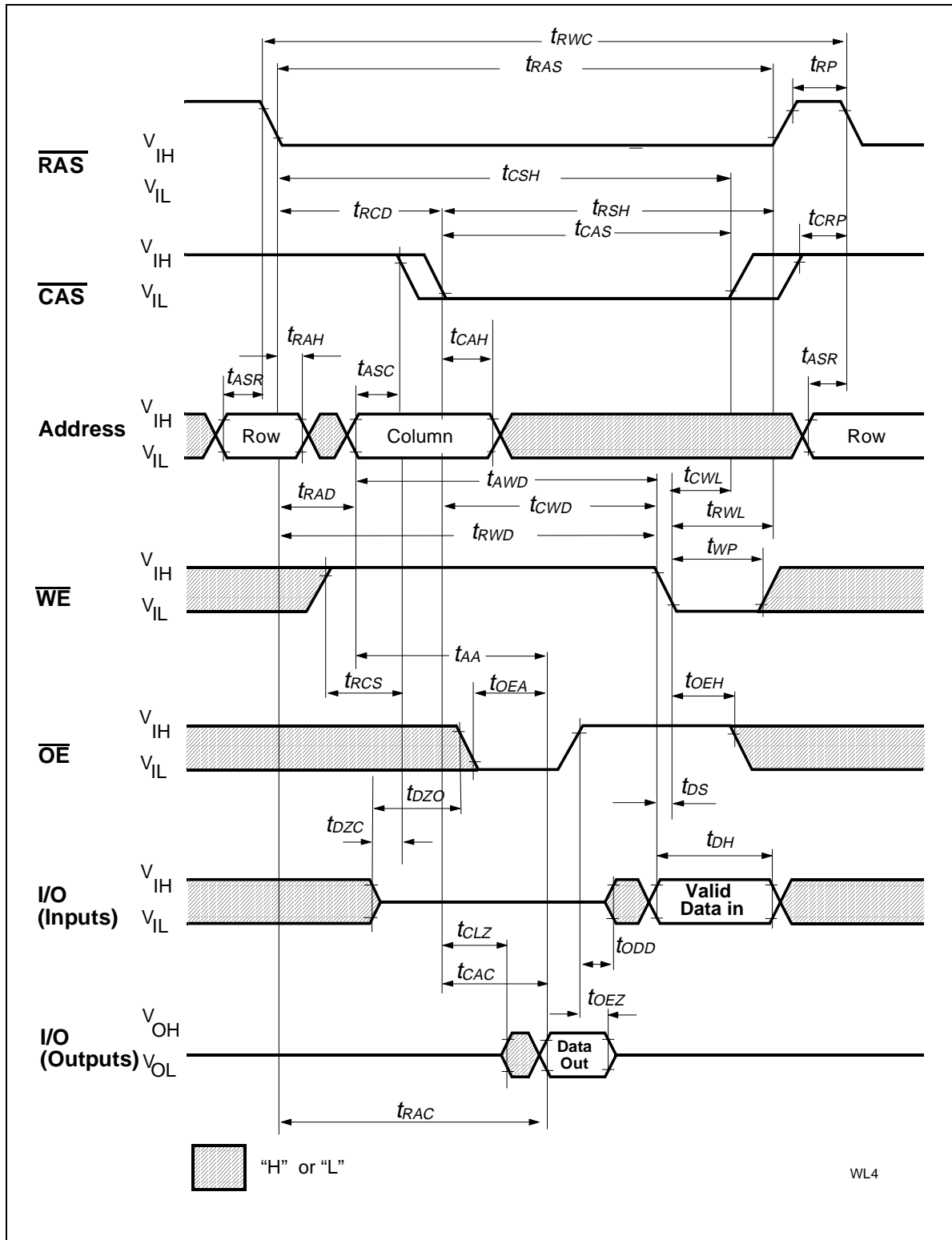

Read-Write (Read-Modify-Write) Cycle

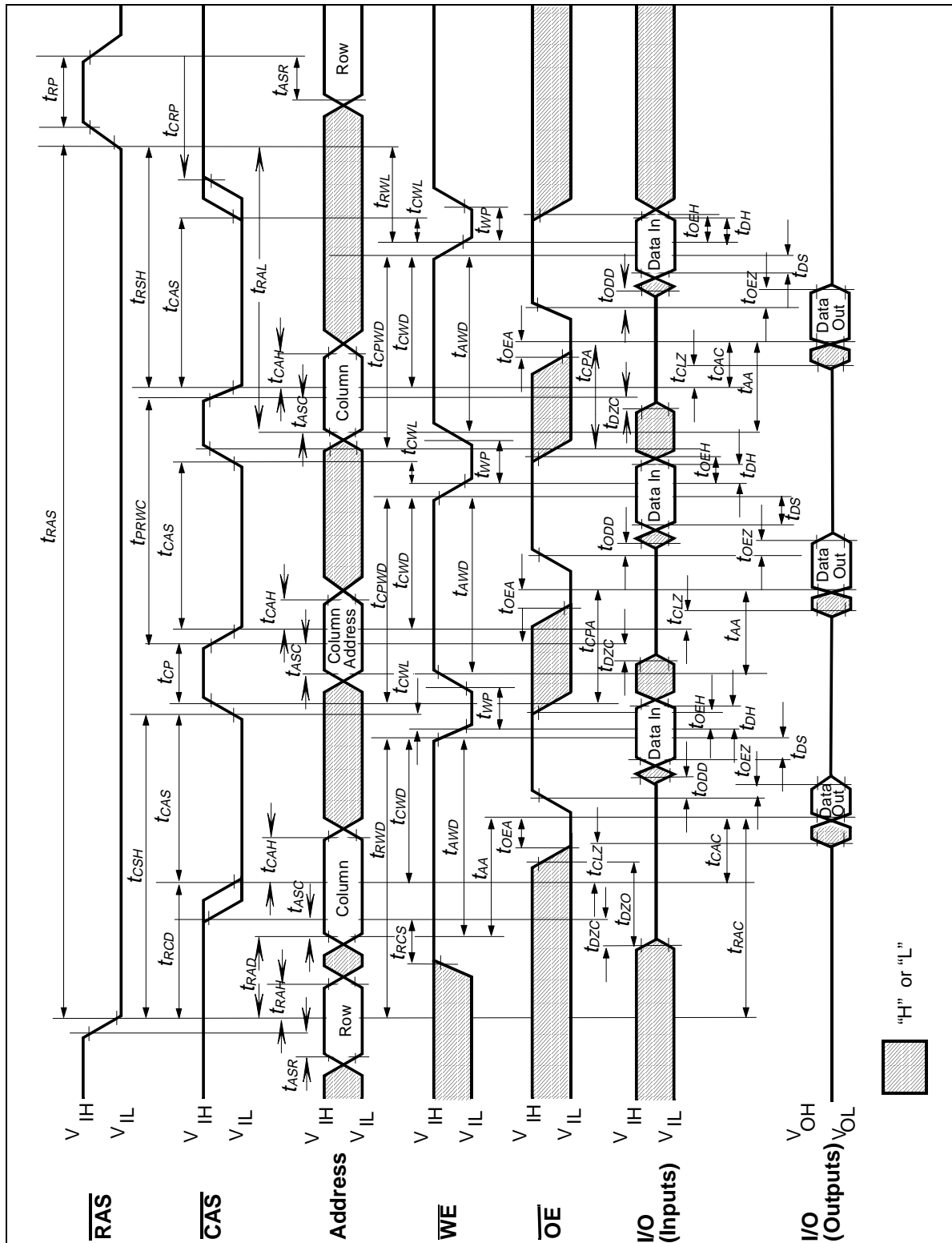

Fast Page Mode Read-Modify-Write Cycle

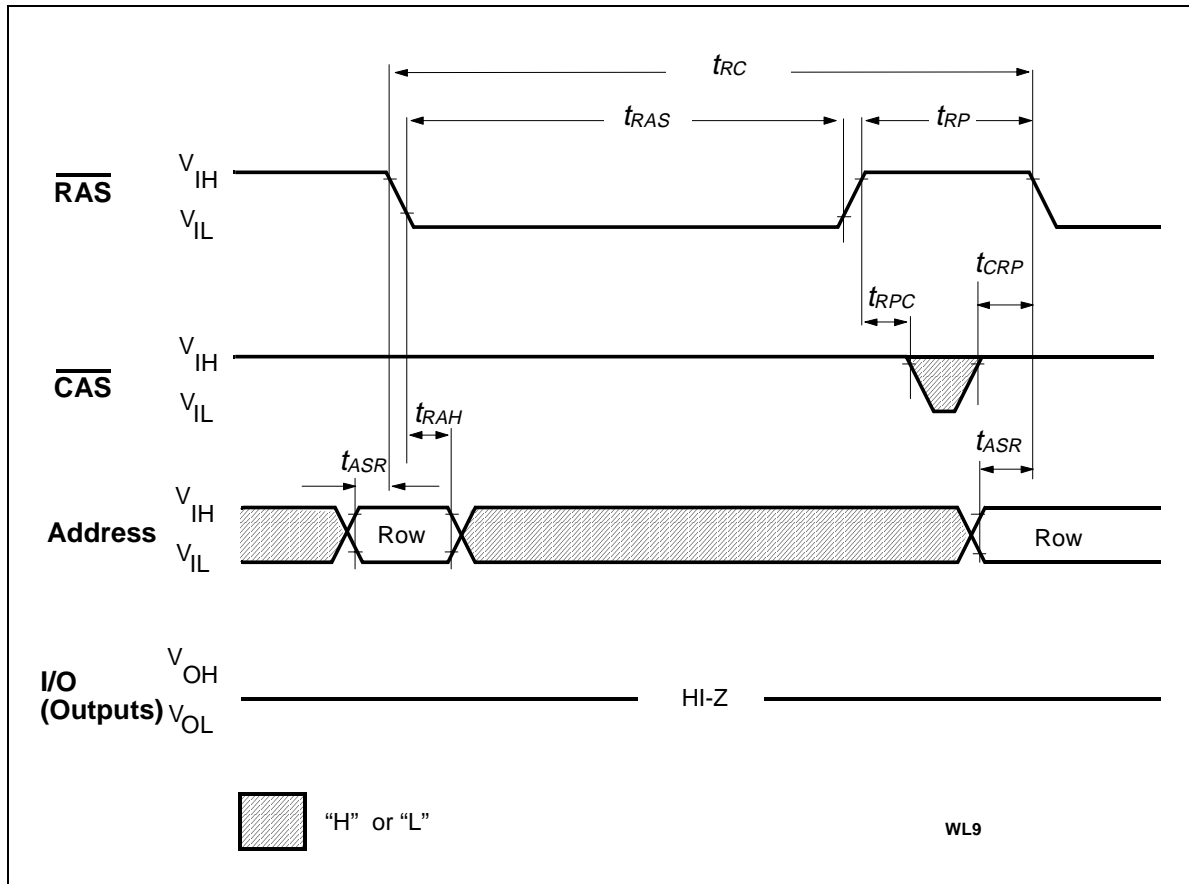

$\overline{\text{RAS}}$ -Only Refresh Cycle

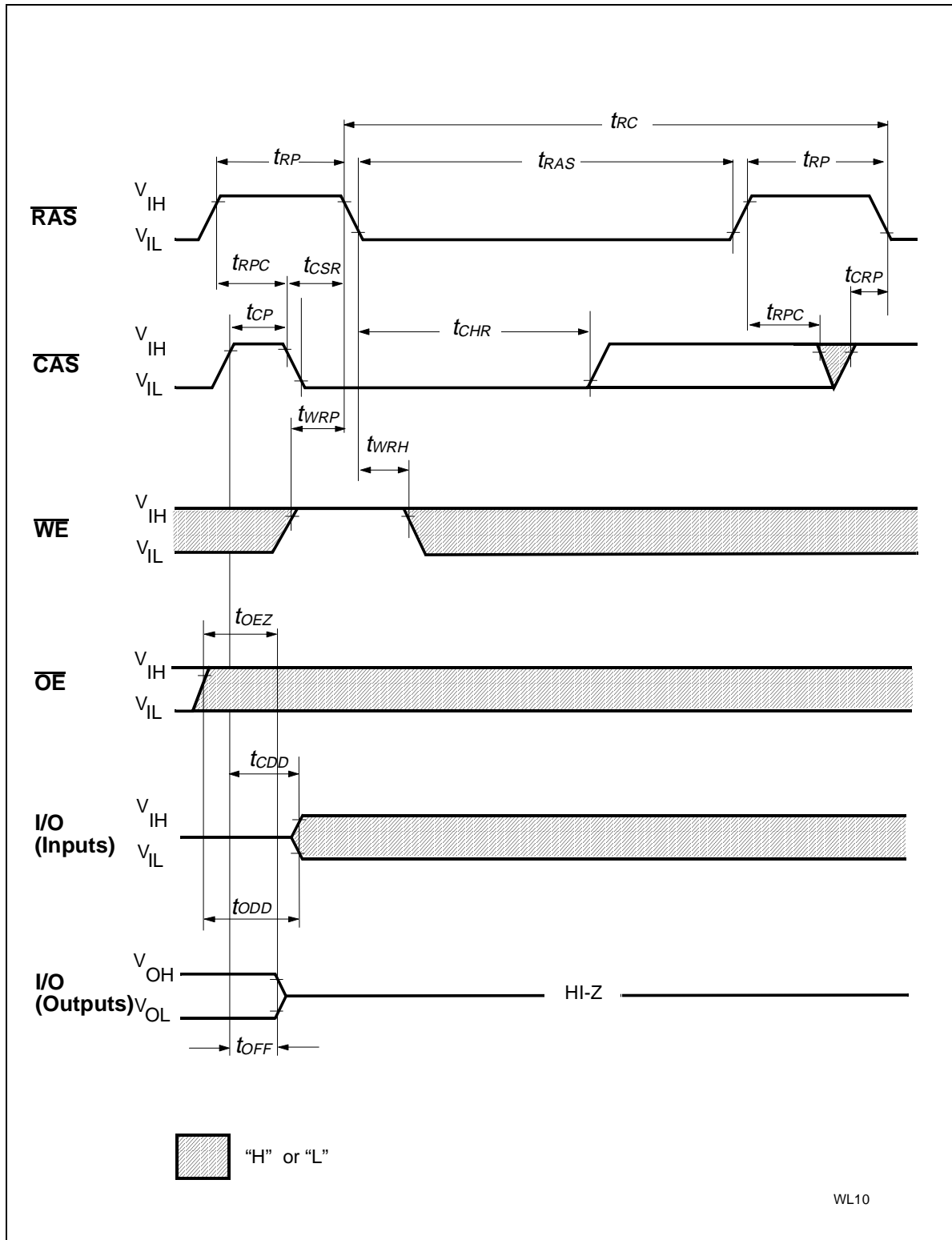

CAS-Before-RAS Refresh Cycle

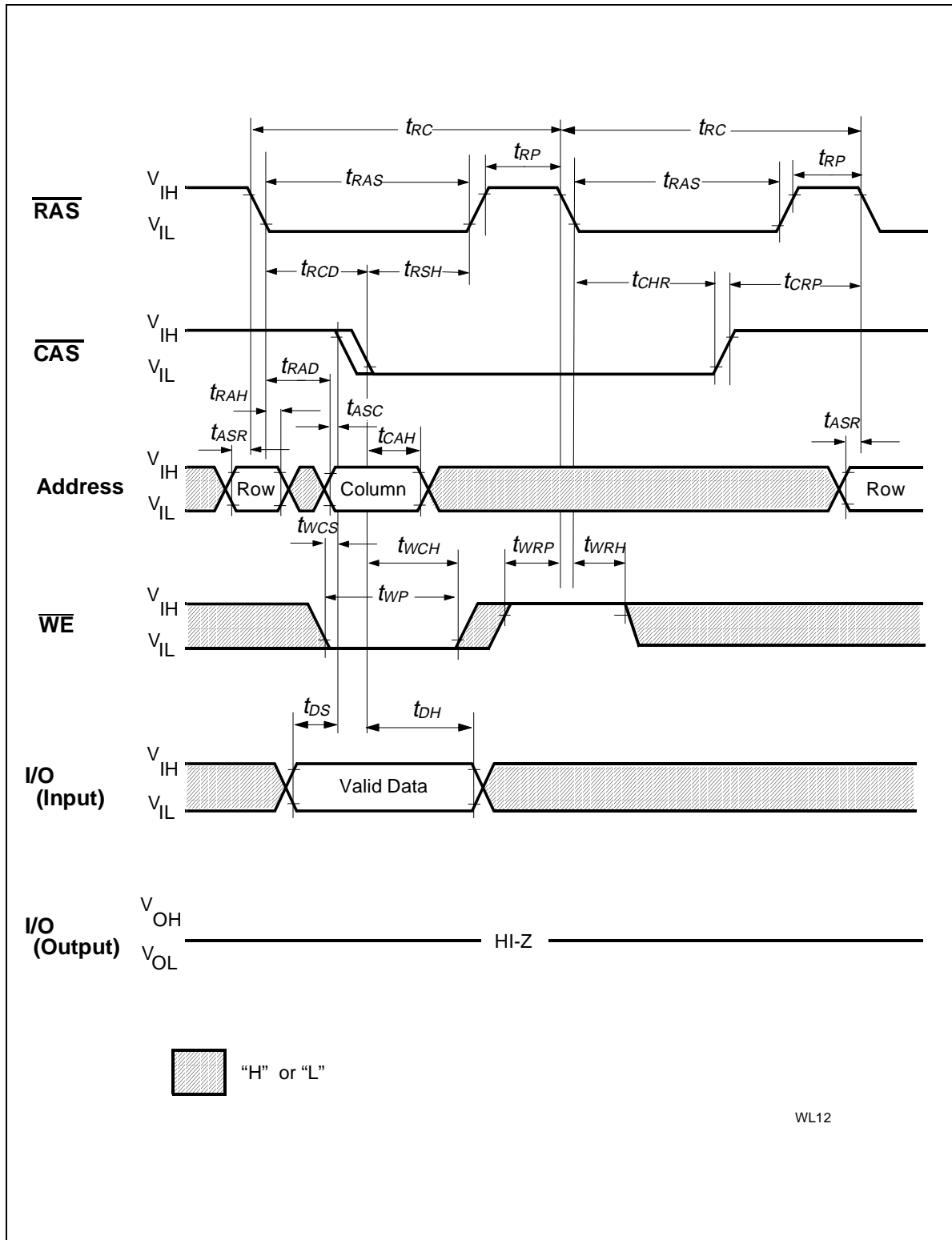

Hidden Refresh Cycle (Early Write)

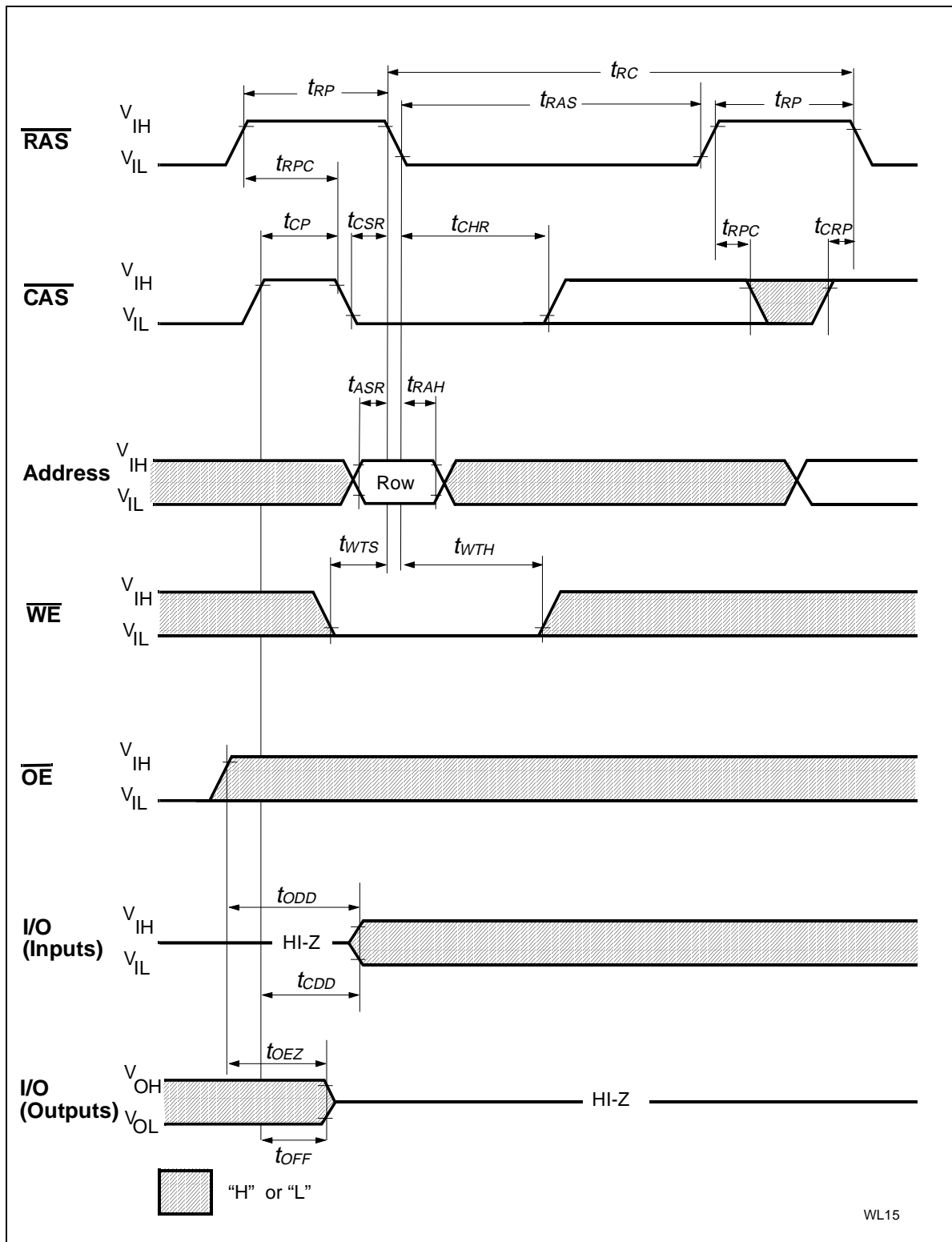

WL15

Test Mode Entry Cycle

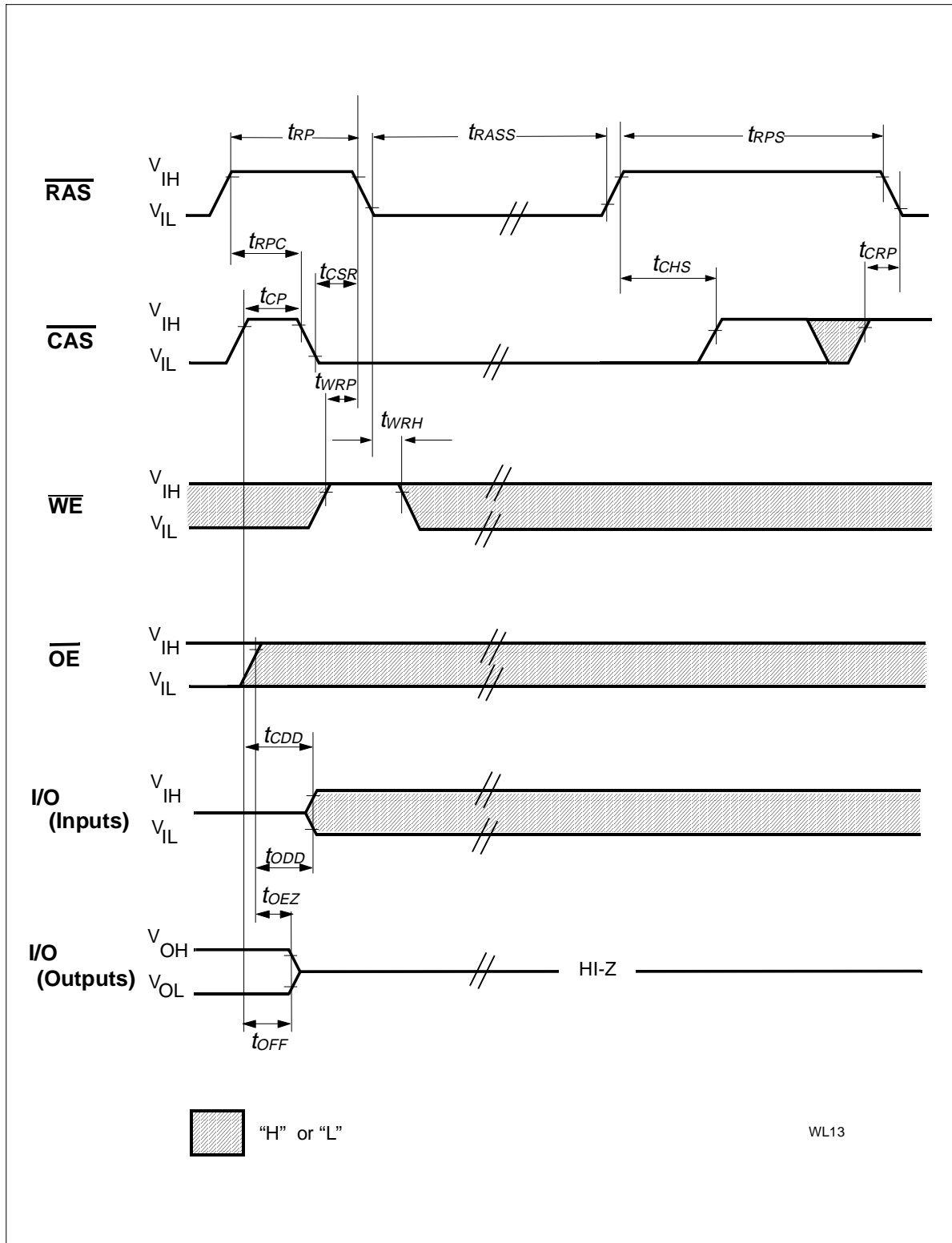

Self Refresh („Sleep Mode“) L-version only

Package Outlines

Plastic Package P-SOJ-32-1 (400 mil)
(Small Outline J-lead, SMD)

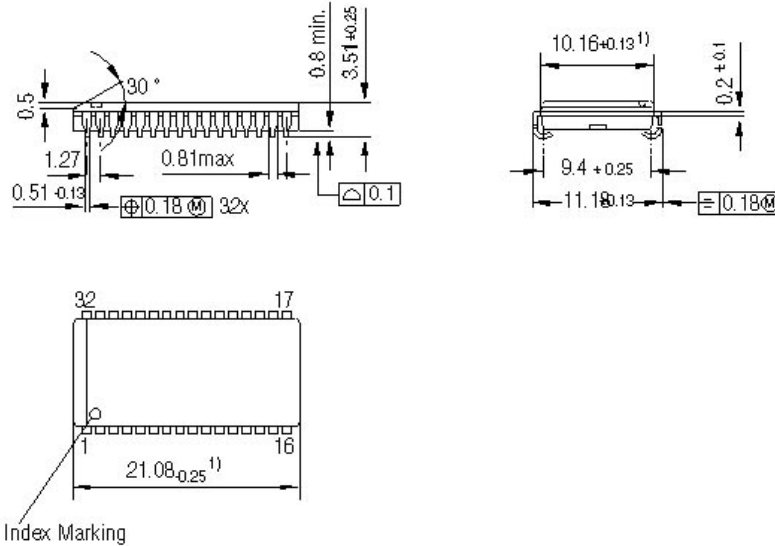

1) Does not include plastic or metal protrusion of 0.15 max. per side

Plastic Package P-TSOPII-32-1 (400 mil)
(Small Outline J-lead, SMD)

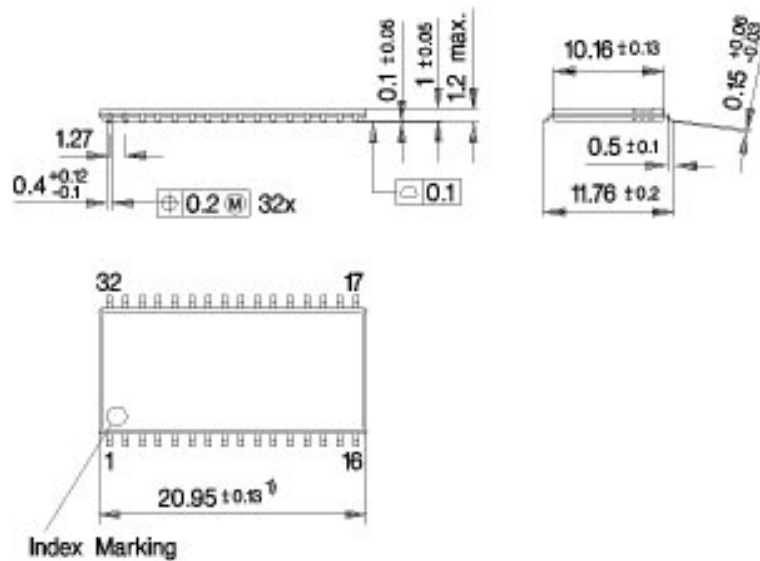

1) Does not include plastic or metal protrusion of 0.25 max. per side