



ICs for Communications

Digital Answering Machine
SAM

PSB 2168 Version 2.1

Data Sheet 11.97

| | | |
|----------------------------------|-----------------------------|--|
| PSB 2168 | | |
| Revision History: | | Current Version: 11.97 |
| Previous Version: | | Preliminary Data Sheet 09.97 |
| Page (in previous Version) | Page (in new Version) | Subjects (major changes since last revision) |
| | | Index added |

For questions on technology, delivery and prices please contact the Semiconductor Group Offices in Germany or the Siemens Companies and Representatives worldwide: see our webpage at <http://www.siemens.de/Semiconductor/address/address.htm>.

Edition 11.97

**Published by Siemens AG,
HL TS,
Balanstraße 73,
81541 München**

© Siemens AG 1997.
All Rights Reserved.

Attention please!

As far as patents or other rights of third parties are concerned, liability is only assumed for components, not for applications, processes and circuits implemented within components or assemblies.

The information describes the type of component and shall not be considered as assured characteristics.

Terms of delivery and rights to change design reserved.

Due to technical requirements components may contain dangerous substances. For information on the types in question please contact your nearest Siemens Office, Semiconductor Group.

Siemens AG is an approved CECC manufacturer.

Packing

Please use the recycling operators known to you. We can also help you – get in touch with your nearest sales office. By agreement we will take packing material back, if it is sorted. You must bear the costs of transport.

For packing material that is returned to us unsorted or which we are not obliged to accept, we shall have to invoice you for any costs incurred.

Components used in life-support devices or systems must be expressly authorized for such purpose!

Critical components¹ of the Semiconductor Group of Siemens AG, may only be used in life-support devices or systems² with the express written approval of the Semiconductor Group of Siemens AG.

- 1 A critical component is a component used in a life-support device or system whose failure can reasonably be expected to cause the failure of that life-support device or system, or to affect its safety or effectiveness of that device or system.
- 2 Life support devices or systems are intended (a) to be implanted in the human body, or (b) to support and/or maintain and sustain human life. If they fail, it is reasonable to assume that the health of the user may be endangered.

| | | |
|----------|---------------------------------------|----|
| 1 | Overview | 10 |
| 1.1 | Features | 11 |
| 1.2 | Pin Configuration | 12 |
| 1.3 | Pin Definitions and Functions | 13 |
| 1.4 | Logic Symbol | 16 |
| 1.5 | Functional Block Diagram | 17 |
| 1.6 | System Integration | 17 |
| 1.6.1 | Stand-Alone Answering Machine | 19 |
| 2 | Functional Description | 21 |
| 2.1 | Functional Units | 24 |
| 2.1.1 | Line Echo Canceller | 24 |
| 2.1.2 | DTMF Detector | 26 |
| 2.1.3 | CNG Detector | 27 |
| 2.1.4 | Alert Tone Detector | 28 |
| 2.1.5 | CPT Detector | 29 |
| 2.1.6 | Caller ID Decoder | 31 |
| 2.1.7 | DTMF Generator | 33 |
| 2.1.8 | Speech Coder | 34 |
| 2.1.9 | Speech Decoder | 36 |
| 2.1.10 | Digital Interface | 37 |
| 2.1.11 | Universal Attenuator | 39 |
| 2.1.12 | Automatic Gain Control Unit | 40 |
| 2.1.13 | Equalizer | 42 |
| 2.2 | Memory Management | 44 |
| 2.2.1 | File Definition and Access | 45 |
| 2.2.2 | User Data Word | 47 |
| 2.2.3 | High Level Memory Management Commands | 48 |
| 2.2.4 | Low Level Memory Management Commands | 56 |
| 2.2.5 | Execution Time | 58 |
| 2.2.6 | Special Notes on File Commands | 59 |
| 2.3 | Miscellaneous | 60 |
| 2.3.1 | Real Time Clock | 60 |
| 2.3.2 | SPS Control Register | 60 |
| 2.3.3 | Reset and Power Down Mode | 60 |
| 2.3.4 | Interrupt | 61 |
| 2.3.5 | Abort | 62 |
| 2.3.6 | Revision Register | 63 |
| 2.3.7 | Hardware Configuration | 63 |
| 2.3.8 | Auxiliary Clock Generation | 64 |
| 2.3.9 | Dependencies of Modules | 64 |
| 2.4 | Interfaces | 66 |
| 2.4.1 | IOM [®] -2 Interface | 66 |

| | | |
|----------|--|------------|
| 2.4.2 | SSDI Interface | 70 |
| 2.4.3 | Serial Control Interface | 72 |
| 2.4.4 | Memory Interface | 76 |
| 2.4.5 | Auxiliary Parallel Port | 85 |
| 3 | Detailed Register Description | 87 |
| 3.1 | Status Register | 87 |
| 3.2 | Hardware Configuration Registers | 89 |
| 3.3 | Read/Write Registers | 93 |
| 3.3.1 | Register Table | 93 |
| 3.3.2 | Register Naming Conventions | 94 |
| 4 | Electrical Characteristics | 160 |
| 4.1 | Absolute Maximum Ratings | 160 |
| 4.2 | DC Characteristics | 160 |
| 4.3 | AC Characteristics | 162 |
| 5 | Package Outlines | 182 |

IOM®, IOM®-1, IOM®-2, SICOFI®, SICOFI®-2, SICOFI®-4, SICOFI®-4μC, SLICOFI®, ARCOFI®, ARCOFI®-BA, ARCOFI®-SP, EPIC®-1, EPIC®-S, ELIC®, IPAT®-2, ITAC®, ISAC®-S, ISAC®-S TE, ISAC®-P, ISAC®-P TE, IDEC®, SICAT®, OCTAT®-P, QUAT®-S are registered trademarks of Siemens AG.

DigiTape™, MUSAC™-A, FALC™54, IWE™, SARE™, UTPT™, ASM™, ASP™ are trademarks of Siemens AG.

| List of Figures | Page |
|--|-------------|
| General | |
| Figure 1: Pin Configuration of PSB 2168 | 12 |
| Figure 2: Logic Symbol of PSB 2168 | 16 |
| Figure 3: Block Diagram of PSB 2168 | 17 |
| Figure 4: Featurephone with Answering Machine for ISDN Terminal | 18 |
| Figure 5: Stand-Alone Answering Machine with ARAM/EPROM | 19 |
| Figure 6: Stand-Alone Answering Machine with Flash Memory | 20 |
| Functional Units | |
| Figure 7: Functional Units - Overview | 21 |
| Figure 8: Functional Units - Recording a Phone Conversation | 23 |
| Figure 9: Line Echo Cancellation Unit - Block Diagram | 24 |
| Figure 10: DTMF Detector - Block Diagram | 26 |
| Figure 11: CNG Detector - Block Diagram | 27 |
| Figure 12: Alert Tone Detector - Block Diagram | 28 |
| Figure 13: CPT Detector - Block Diagram | 29 |
| Figure 14: CPT Detector - Cooked Mode | 29 |
| Figure 15: Caller ID Decoder - Block Diagram | 31 |
| Figure 16: DTMF Generator - Block Diagram | 33 |
| Figure 17: Speech Coder - Block Diagram | 34 |
| Figure 18: Speech Decoder - Block Diagram | 36 |
| Figure 19: Digital Interface - Block Diagram | 37 |
| Figure 20: Universal Attenuator - Block Diagram | 39 |
| Figure 21: Automatic Gain Control Unit - Block Diagram | 40 |
| Figure 22: Automatic Gain Control Unit - Steady State Characteristic | 40 |
| Figure 23: Equalizer - Block Diagram | 42 |
| Memory Management | |
| Figure 24: Memory Management - Data Flow | 44 |
| Figure 25: Memory Management - Directory Structure | 44 |
| Figure 26: Audio File Organization - Example | 45 |
| Figure 27: Binary File Organization - Example | 45 |
| Figure 28: Phrase File Organization - Example | 46 |
| Miscellaneous | |
| Figure 29: Operation Modes - State Chart | 61 |
| Interfaces | |
| Figure 30: IOM [®] -2 Interface - Frame Structure | 66 |
| Figure 31: IOM [®] -2 Interface - Frame Start | 67 |
| Figure 32: IOM [®] -2 Interface - Single Clock Mode | 67 |
| Figure 33: IOM [®] -2 Interface - Double Clock Mode | 68 |
| Figure 34: SSDI Interface - Transmitter Timing | 70 |

| List of Figures | Page |
|---|-------------|
| Figure 35: SSDI Interface - Active Pulse Selection | 71 |
| Figure 36: SSDI Interface - Receiver Timing | 71 |
| Figure 37: Status Register Read Access | 72 |
| Figure 38: Data Read Access | 73 |
| Figure 39: Register Write Access | 73 |
| Figure 40: Configuration Register Read Access | 74 |
| Figure 41: Configuration Register Write Access or Register Read Command | 74 |
| Figure 42: ARAM/DRAM Interface - Connection Diagram | 77 |
| Figure 43: ARAM/DRAM Interface - Read Cycle Timing | 78 |
| Figure 44: ARAM/DRAM Interface - Write Cycle Timing | 79 |
| Figure 45: ARAM/DRAM Interface - Refresh Cycle Timing | 79 |
| Figure 46: EPROM Interface - Connection Diagram | 80 |
| Figure 47: EPROM Interface - Read Cycle Timing | 80 |
| Figure 48: Flash Memory Interface - Connection Diagram | 81 |
| Figure 49: Flash Memory Interface - Multiple Devices | 82 |
| Figure 50: Flash Memory Interface - Command Write | 83 |
| Figure 51: Flash Memory Interface - Address Write | 83 |
| Figure 52: Flash Memory Interface - Data Write | 84 |
| Figure 53: Flash Memory Interface - Data Read | 84 |
| Figure 54: Auxiliary Parallel Port - Multiplex Mode | 86 |

Electrical Characteristics

| | |
|--|-----|
| Figure 55: Input/Output Waveforms for AC-Tests | 162 |
|--|-----|

Timing Diagrams

| | |
|--|-----|
| Figure 56: Oscillator Circuits | 166 |
| Figure 57: SSDI/IOM [®] -2 Interface - Bit Synchronization Timing | 167 |
| Figure 58: SSDI/IOM [®] -2 Interface - Frame Synchronization Timing | 167 |
| Figure 59: SSDI Interface - Strobe Timing | 169 |
| Figure 60: Serial Control Interface | 170 |
| Figure 61: Clock Master Timing | 171 |
| Figure 62: Memory Interface - DRAM Read Access | 172 |
| Figure 63: Memory Interface - DRAM Write Access | 173 |
| Figure 64: Memory Interface - DRAM Refresh Cycle | 174 |
| Figure 65: Memory Interface - EPROM Read | 175 |
| Figure 66: Memory Interface - Samsung Command Write | 176 |
| Figure 67: Memory Interface - Samsung Address Write | 177 |
| Figure 68: Memory Interface - Samsung Data Write | 178 |
| Figure 69: Memory Interface - Samsung Data Read | 179 |
| Figure 70: Auxiliary Parallel Port - Multiplex Mode | 180 |
| Figure 71: Reset Timing | 181 |

| List of Tables | Page |
|---|-------------|
| General | |
| Table 1: Pin Definitions and Functions | 13 |
| Functional Units | |
| Table 2: Signal Summary | 22 |
| Table 3: Line Echo Cancellation Unit Registers | 25 |
| Table 4: DTMF Detector Control Register | 26 |
| Table 5: DTMF Detector Results | 26 |
| Table 6: DTMF Detector Parameters | 26 |
| Table 7: CNG Detector Registers | 27 |
| Table 8: CNG Detector Result | 27 |
| Table 9: Alert Tone Detector Registers | 28 |
| Table 10: Alert Tone Detector Results | 28 |
| Table 11: CPT Detector Result | 30 |
| Table 12: CPT Detector Registers | 30 |
| Table 13: Caller ID Decoder Modes | 31 |
| Table 14: Caller ID Decoder Status | 31 |
| Table 15: Caller ID Decoder Registers | 31 |
| Table 16: DTMF Generator Registers | 33 |
| Table 17: Speech Coder Status | 34 |
| Table 18: Speech Coder Registers | 35 |
| Table 19: Speech Decoder Registers | 36 |
| Table 20: Digital Interface Registers | 37 |
| Table 21: Universal Attenuator Registers | 39 |
| Table 22: Automatic Gain Control Registers | 41 |
| Table 23: Equalizer Registers | 42 |
| Memory Management - General | |
| Table 24: Memory Management Registers | 46 |
| Table 25: Memory Management Status | 46 |
| Table 26: Memory Management Parameters | 47 |
| Memory Management - Commands | |
| Table 27: Initialize Memory Parameters | 48 |
| Table 28: Initialize Memory Results | 48 |
| Table 29: Activate Memory Parameters | 49 |
| Table 30: Activate Memory Results | 49 |
| Table 31: Activate Memory Result Interpretation | 49 |
| Table 32: Open File Parameters | 50 |
| Table 33: Open Next Free File Parameters | 50 |
| Table 34: Open Next Free File Results | 51 |
| Table 35: Seek Parameters | 51 |
| Table 36: Cut File Parameters | 52 |

| | |
|---|----|
| Table 37: Compress File Parameters | 52 |
| Table 38: Memory Status Parameters | 53 |
| Table 39: Memory Status Results | 53 |
| Table 40: Garbage Collection Parameters | 53 |
| Table 41: Access File Descriptor Parameters | 54 |
| Table 42: Access File Descriptor Results | 54 |
| Table 43: Read Data Parameters | 54 |
| Table 44: Read Data Results | 54 |
| Table 45: Write Data Parameters | 55 |
| Table 46: Set Address Parameters | 56 |
| Table 47: DMA Read Parameters | 56 |
| Table 48: DMA Read Results | 56 |
| Table 49: DMA Write Parameters | 57 |
| Table 50: Block Erase Parameters | 57 |
| Table 51: Execution Times | 58 |

Miscellaneous

| | |
|--|----|
| Table 52: Real Time Clock Registers | 60 |
| Table 53: SPS Registers | 60 |
| Table 54: Power Down Bit | 61 |
| Table 55: Interrupt Source Summary | 62 |
| Table 56: Hardware Configuration Checklist | 63 |
| Table 57: Auxiliary Clock Generation | 64 |
| Table 58: Dependencies of Modules | 64 |
| Table 59: File Command Classes | 65 |

Interfaces

| | |
|--|----|
| Table 60: SSDI vs. IOM [®] -2 Interface | 66 |
| Table 61: IOM [®] -2 Interface Registers | 68 |
| Table 62: SSDI Interface Register | 71 |
| Table 63: Command Words for Register Access | 75 |
| Table 64: Address Field W for Configuration Register Write | 75 |
| Table 65: Address Field R for Configuration Register Read | 75 |
| Table 66: Supported Memory Configurations | 76 |
| Table 67: Address Line Usage (ARAM/DRAM Mode) | 78 |
| Table 68: Refresh Frequency Selection | 79 |
| Table 69: Address Line Usage (Samsung Mode) | 81 |
| Table 70: Flash Memory Command Summary | 82 |
| Table 71: Static Mode Registers | 85 |
| Table 72: Multiplex Mode Registers | 85 |
| Table 73: Signal Encoding | 95 |

Electrical Characteristics

Table 74: Status Register Update Timing165

1 Overview

The PSB 2168 provides a solution for an embedded answering in an IOM[®]-2 based system.

The chip features recording by DigiTape[™], a family of high performance algorithms. Messages recorded with DigiTape[™] can be played back with variable speed without pitch alteration. Messages recorded with a higher bitrate can be converted into messages with a lower bitrate arbitrarily. Current members of DigiTape (TM) span the range from 3.3 kbit/s to 10.3 kbit/s.

Furthermore the PSB 2168, V2.1 has a caller ID decoder, DTMF recognition and generation and call progress tone detection. The frequency response of cheap microphones or loudspeakers can be corrected by a programmable equalizer.

Messages and user data can be stored in ARAM/DRAM or flash memory which can be directly connected to the PSB 2168. The PSB 2168 also supports a voice prompt EPROM for fixed announcements.

The PSB 2168 provides an IOM[®]-2 compatible interface with two channels for speech data.

Alternatively to the IOM[®]-2 compatible interface the PSB 2168 supports a simple serial data interface (SSDI) with separate strobe signals for each direction (linear PCM data, one channel).

The chip is programmed by a simple four wire serial control interface and can inform the microcontroller of new events by an interrupt signal. For data retention the PSB 2168 supports a power down mode where only the real time clock and the memory refresh (in case of ARAM/DRAM) are operational.

The PSB 2168 supports interface pins to +5 V levels.

Version 2.1

CMOS

1.1 Features

Digital Functions

- High performance recording by DigiTape™
- Selectable compression rate (3.3 kbit/s, 10.3 kbit/s)
- Variable playback speed
- Support for ARAM or Flash Memory
- Optional voice prompt EPROM
- DTMF generation and detection
- Call progress tone detection
- Caller ID recognition
- Direct memory access
- Real time clock
- Equalizer
- Automatic gain control
- Automatic timestamp
- Auxiliary parallel port
- Ultra low power refresh mode

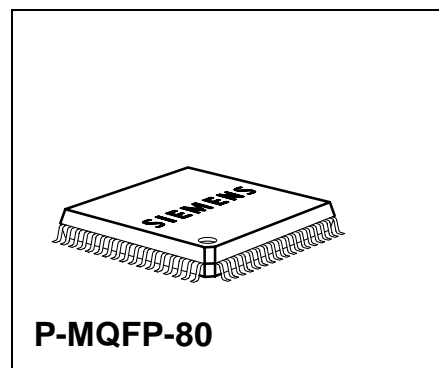

General Features

- SSDI/IOM®-2 compatible interface
- Serial control interface for programming
- Master clock generation for common codecs

| Type | Package |
|----------|-----------|
| PSB 2168 | P-MQFP-80 |

1.2 Pin Configuration
(top view)

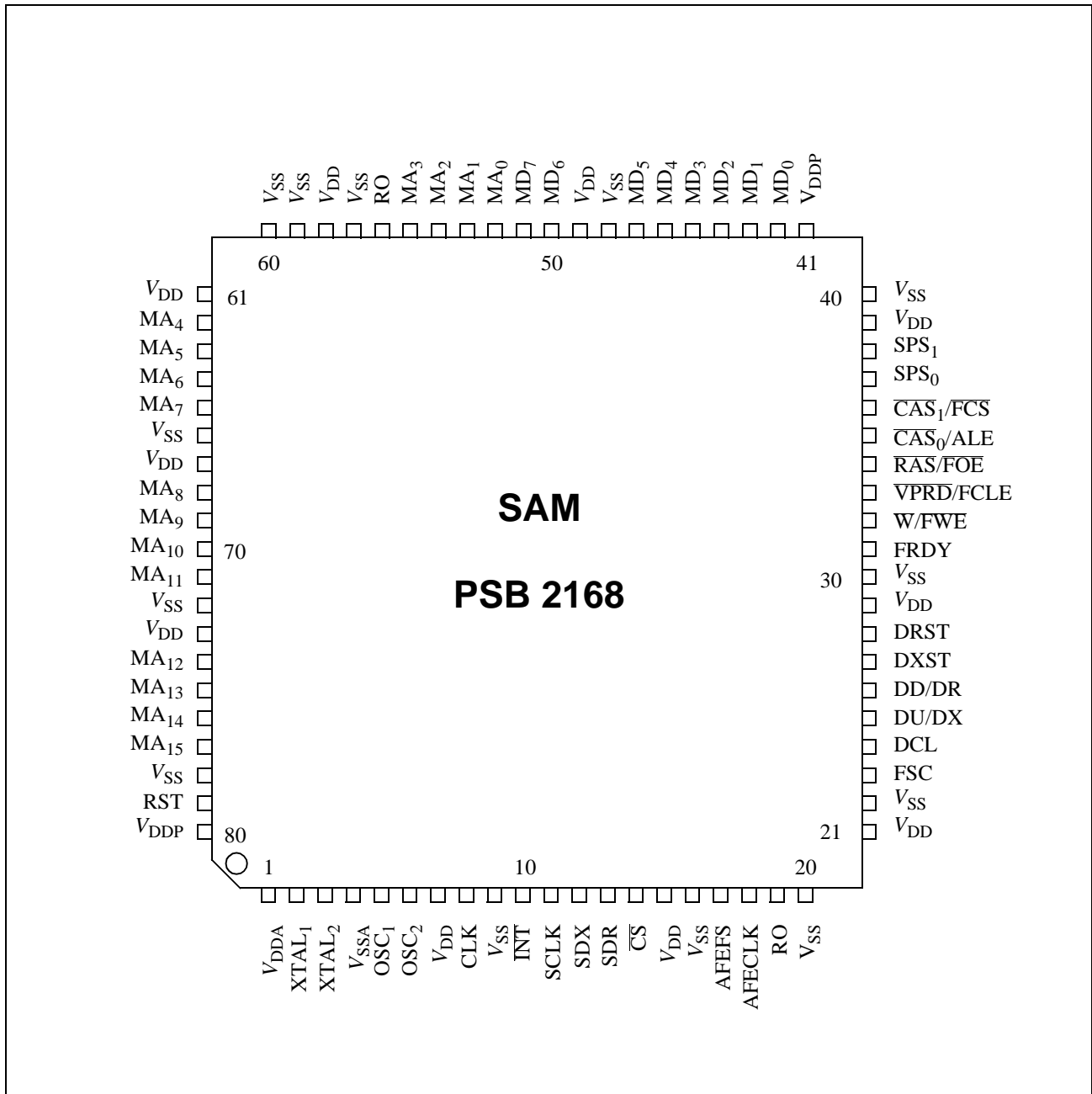

Figure 1 Pin Configuration of PSB 2168

1.3 Pin Definitions and Functions

Table 1 Pin Definitions and Functions

| Pin No. P-MQFP-80 | Symbol | Dir. | Reset | Function |
|---|-----------|-----------|-------|---|
| 41, 80 | V_{DDP} | - | - | Power supply (5V \pm10 %) Power supply for the interface. |
| 7, 15, 21, 29, 39, 49, 58, 61, 67, 73 | V_{DD} | - | - | Power supply (3.0 V - 3.6 V) Power supply for logic. |
| 1 | V_{DDA} | - | - | Power supply (3.0 V - 3.6 V) Power supply for clock generator. |
| 4 | V_{SSA} | - | - | Power supply (0 V) Ground for clock generator. |
| 9, 16, 20, 22, 30, 40, 48, 57, 59, 60, 78, 66, 72 | V_{SS} | - | - | Power supply (0 V) Ground for logic and interface. |
| 17 | AFEFS | O | L | Analog Frontend Frame Sync: 8 kHz frame synchronization signal for the analog front end. |
| 18 | AFECLK | O | L | Analog Frontend Clock: Clock signal for the analog front end. |
| 79 | RST | I | - | Reset: Active high reset signal. |
| 23 | FSC | I | - | Data Frame Synchronization: 8 kHz frame synchronization signal (IOM [®] -2 and SSDI mode). |
| 24 | DCL | I | - | Data Clock: Data Clock of the serial data interface. |
| 26 | DD/DR | I/OD I | - | IOM[®]-2 Compatible Mode: Receive data from IOM [®] -2 controlling device. SSDI Mode: Receive data of the strobed serial data interface. |

Table 1 Pin Definitions and Functions

| | | | | |
|----|------------------|------------------|-----------------|---|
| 25 | DU/DX | I/OD O/ OD | - | IOM[®]-2 Compatible Mode: Transmit data to IOM [®] -2 controlling device. SSDI Mode: Transmit data of the strobed serial data interface. |
| 27 | DXST | O | L | DX Strobe: Strobe for DX in SSDI interface mode. |
| 28 | DRST | I | - | DR Strobe: Strobe for DR in SSDI interface mode. |
| 14 | \overline{CS} | I | - | Chip Select: Select signal of the serial control interface (SCI). |
| 11 | SCLK | I | - | Serial Clock: Clock signal of the serial control interface (SCI). |
| 13 | SDR | I | - | Serial Data Receive: Data input of the serial control interface (SCI). |
| 12 | SDX | O/ OD | H | Serial Data Transmit: Data Output of the serial control interface (SCI). |
| 10 | \overline{INT} | O/ OD | H | Interrupt New status available. |
| 52 | MA ₀ | I/O | L ¹⁾ | Memory Address 0-15: Multiplexed address outputs for ARAM, DRAM access. Non-multiplexed address outputs for voice prompt EPROM. Auxiliary Parallel Port: General purpose I/O. |
| 53 | MA ₁ | I/O | L | |
| 54 | MA ₂ | I/O | L | |
| 55 | MA ₃ | I/O | L | |
| 62 | MA ₄ | I/O | L | |
| 63 | MA ₅ | I/O | L | |
| 64 | MA ₆ | I/O | L | |
| 65 | MA ₇ | I/O | L | |
| 68 | MA ₈ | I/O | L | |
| 69 | MA ₉ | I/O | L | |
| 70 | MA ₁₀ | I/O | L | |
| 71 | MA ₁₁ | I/O | L | |
| 74 | MA ₁₂ | I/O | L | |
| 75 | MA ₁₃ | I/O | L | |
| 76 | MA ₁₄ | I/O | L | |
| 77 | MA ₁₅ | I/O | L | |

Table 1 Pin Definitions and Functions

| | | | | |
|----|--|-----|-----------------|---|
| 42 | MD ₀ | I/O | - | Memory Data 0-7: Memory (ARAM, DRAM, Flash Memory, EPROM) data bus. |
| 43 | MD ₁ | I/O | - | |
| 44 | MD ₂ | I/O | - | |
| 45 | MD ₃ | I/O | - | |
| 46 | MD ₄ | I/O | - | |
| 47 | MD ₅ | I/O | - | |
| 50 | MD ₆ | I/O | - | |
| 51 | MD ₇ | I/O | - | |
| 35 | $\overline{\text{CAS}}_0$ / ALE | O | H ²⁾ | ARAM, DRAM: Column address strobe for memory bank 0 or 1. |
| 36 | $\overline{\text{CAS}}_1$ / $\overline{\text{FCS}}$ | O | | Flash Memory: Address Latch Enable for address lines A ₁₆ -A ₂₃ . Chip select signal for Flash Memory |
| 34 | $\overline{\text{RAS}}$ / $\overline{\text{FOE}}$ | O | H ²⁾ | ARAM, DRAM: Row address strobe for both memory banks. Flash Memory: Output enable signal for Flash Memory. |
| 33 | $\overline{\text{VPRD}}$ / FCLE | O | H ²⁾ | ARAM, DRAM: Read signal for voice prompt EPROM. Flash Memory: Command latch enable for Flash Memory. |
| 32 | W/FWE | O | H ²⁾ | ARAM, DRAM: Write signal for all memory banks. Flash Memory: Write signal for Flash Memory. |
| 31 | FRDY | I | - | Flash Memory Ready Input for Ready/Busy signal of Flash Memory |
| 5 | OSC ₁ | I | - | Auxiliary Oscillator: Oscillator loop for 32.768 kHz crystal. |
| 6 | OSC ₂ | O | Z | |
| 8 | CLK | I | - | Alternative AFCLK Source 13,824 MHz |
| 2 | XTAL ₁ | I | - | Oscillator: XTAL ₁ : External clock or input of oscillator loop. XTAL ₂ : output of oscillator loop for crystal. |
| 3 | XTAL ₂ | O | Z | |

Table 1 Pin Definitions and Functions

| | | | | |
|--------|------------------|---|---|--|
| 37 | SPS ₀ | O | L | Multipurpose Outputs: General purpose, address lines or status |
| 38 | SPS ₁ | O | L | |
| 19, 56 | RO | O | - | Reserved Output Must be left open. |

- 1) These lines are driven low with 125 μA until the mode (address lines or auxiliary port) is defined.
- 2) These lines are driven high with 70 μA during reset.

1.4 Logic Symbol

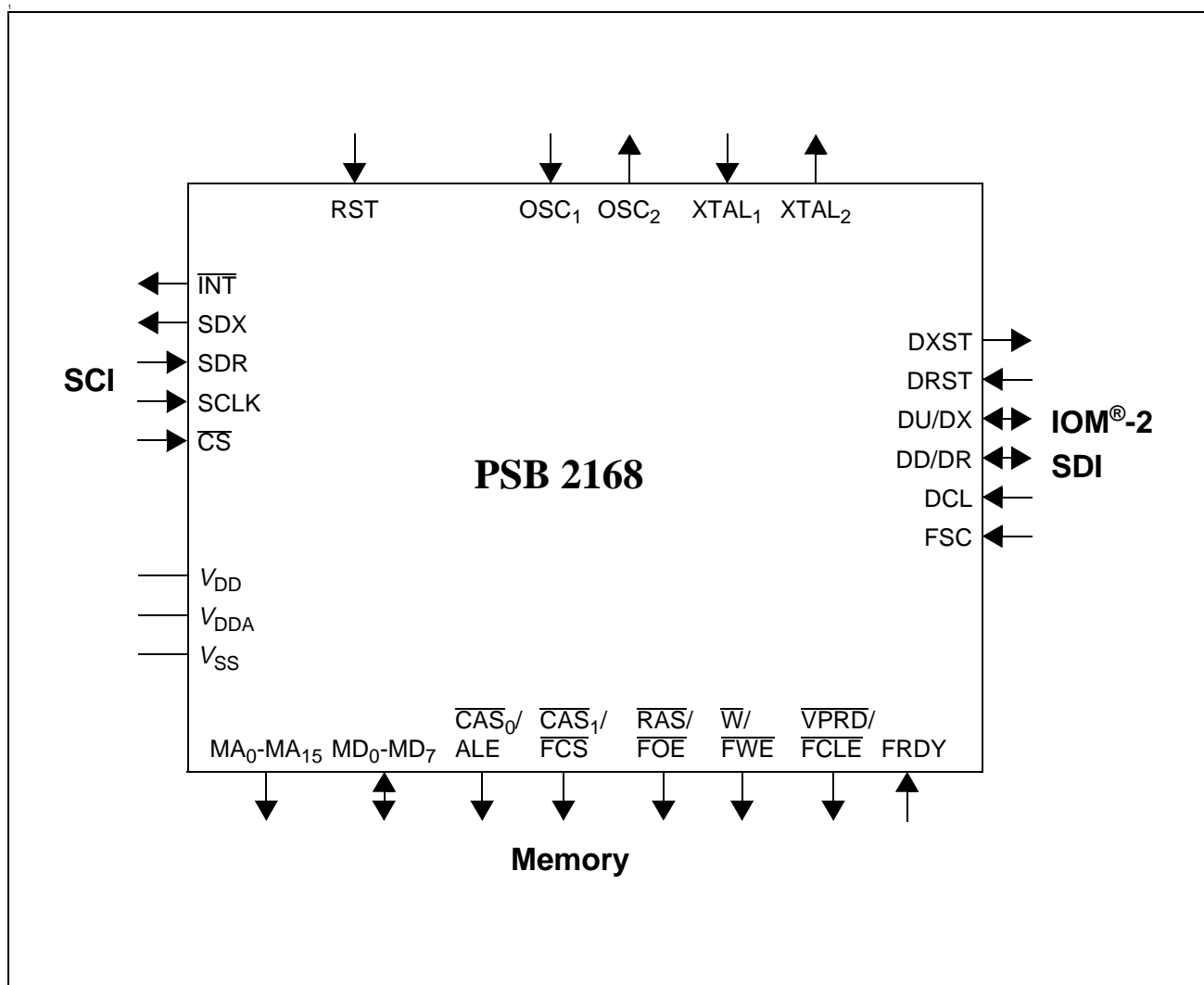

Figure 2 Logic Symbol of PSB 2168

1.5 Functional Block Diagram

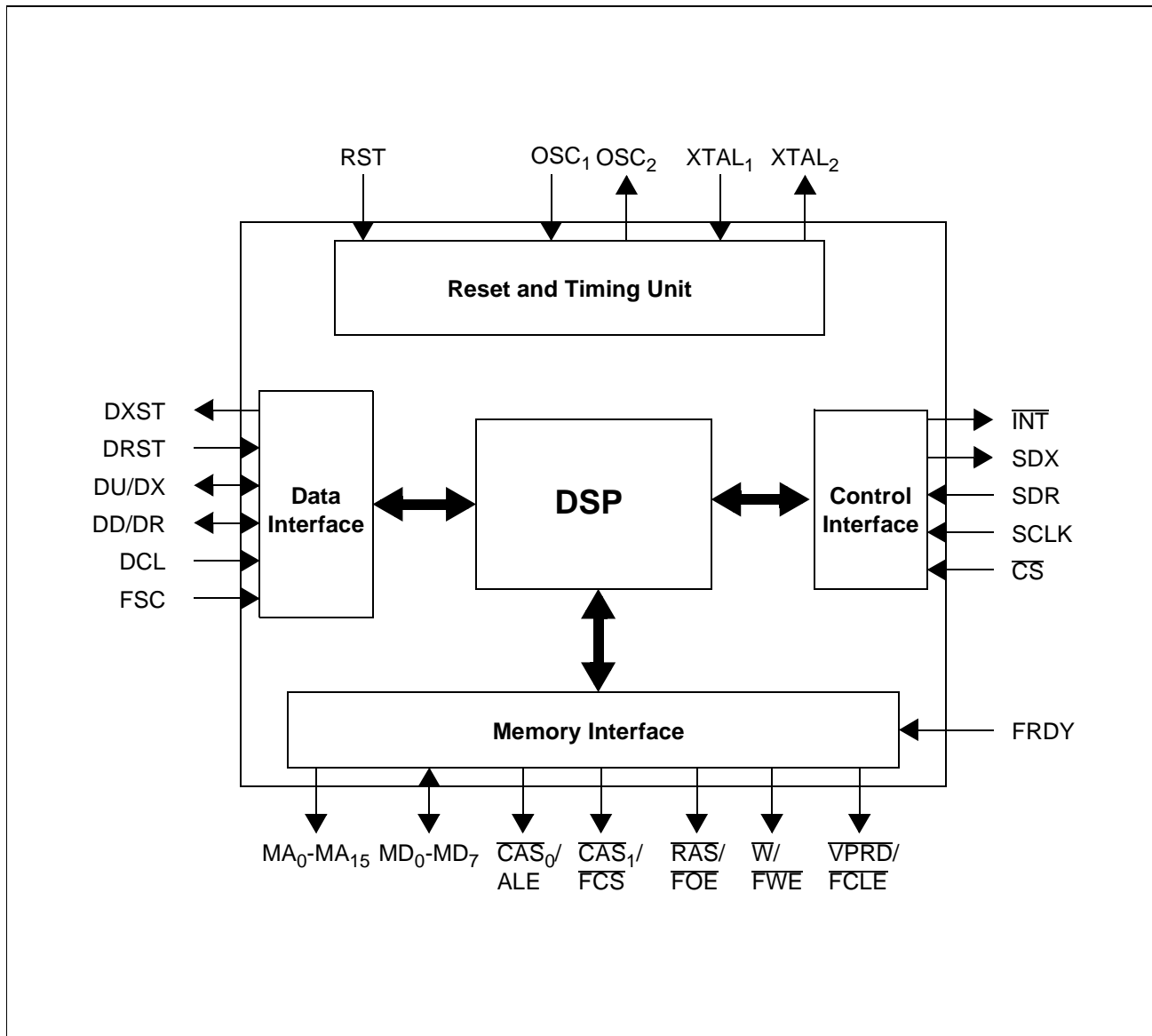

Figure 3 Block Diagram of PSB 2168

1.6 System Integration

The integration into an ISDN terminal is shown in figure 4. All voice data is transferred by the IOM®-2 compatible interface. The PSB 2168 is programmed by the SCI interface. The PSB 2163 is programmed by the IOM®-2 interface. The microcontroller can access the memory attached to the PSB 2168. This is useful for storing system parameters or phonebook entries.

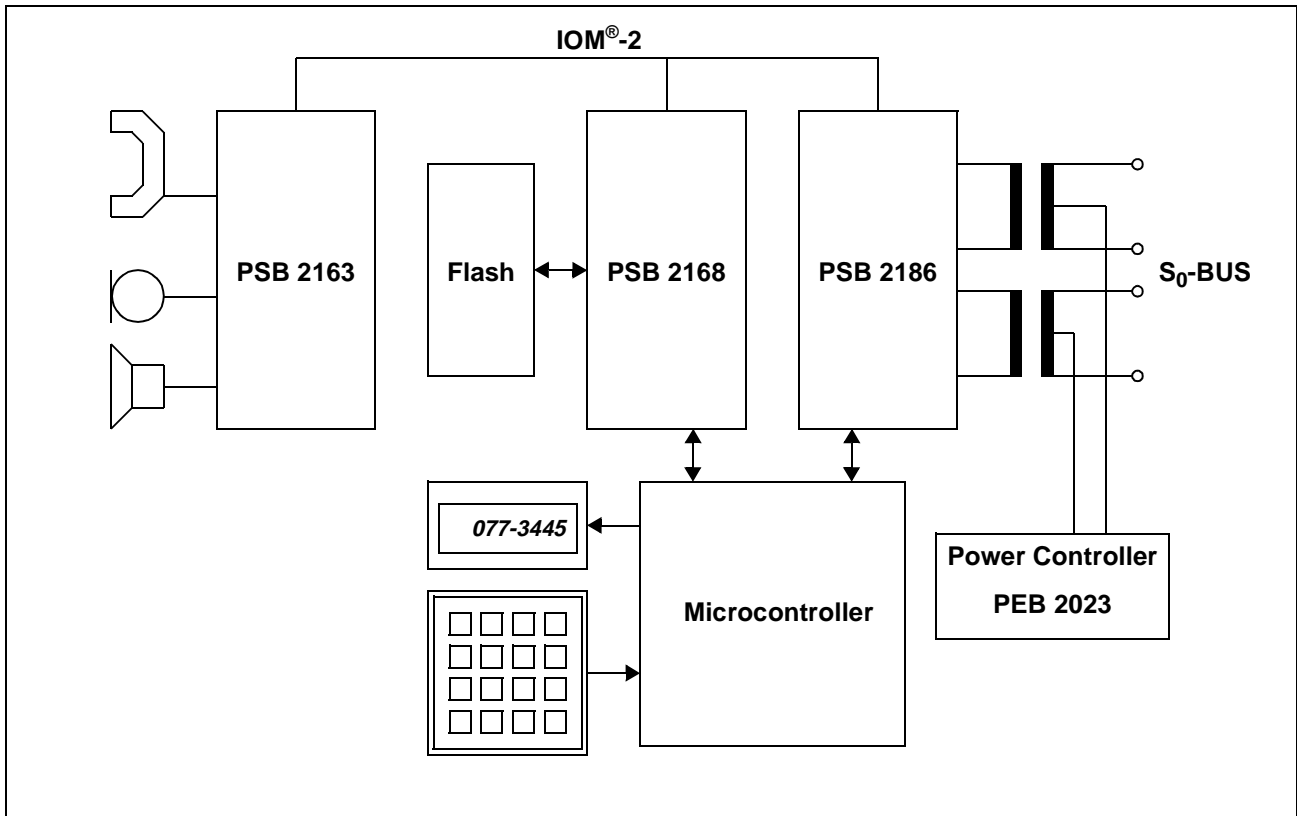

Figure 4 Featurephone with Answering Machine for ISDN Terminal

1.6.1 Stand-Alone Answering Machine

The PSB 2168 can also be used in conjunction with a simple codec for a stand-alone answering machine (figure 5). In this application the PSB 2168 generates the necessary clocks for the simple codec at the pins AFECLK and AFEFS. Therefore the simple codec can be connected without further glue logic.

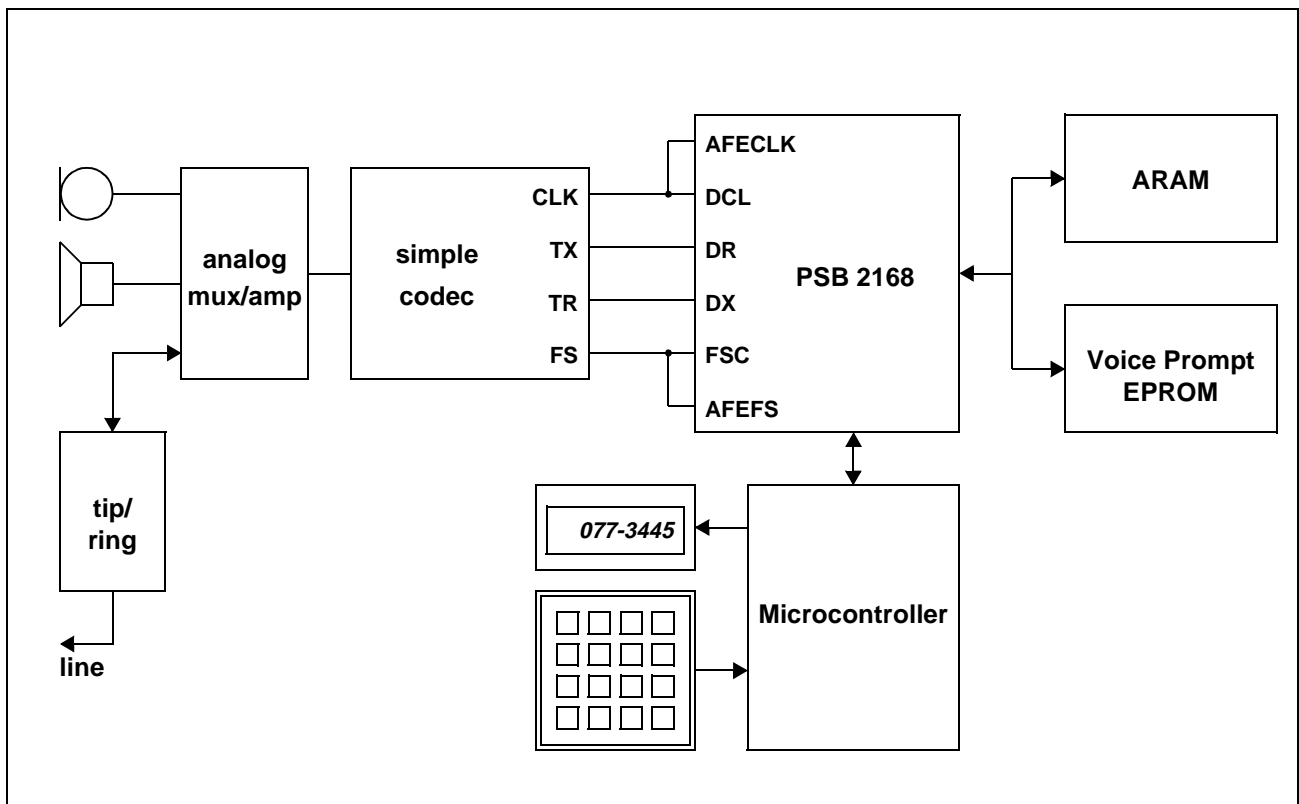

Figure 5 Stand-Alone Answering Machine with ARAM/EPROM

Overview

Furthermore the PSB 2168 can be used to scan the keyboard and drive the display if instead of ARAM/DRAM and EPROM flash memory devices (SAMSUNG mode) are used for storage (figure 6).

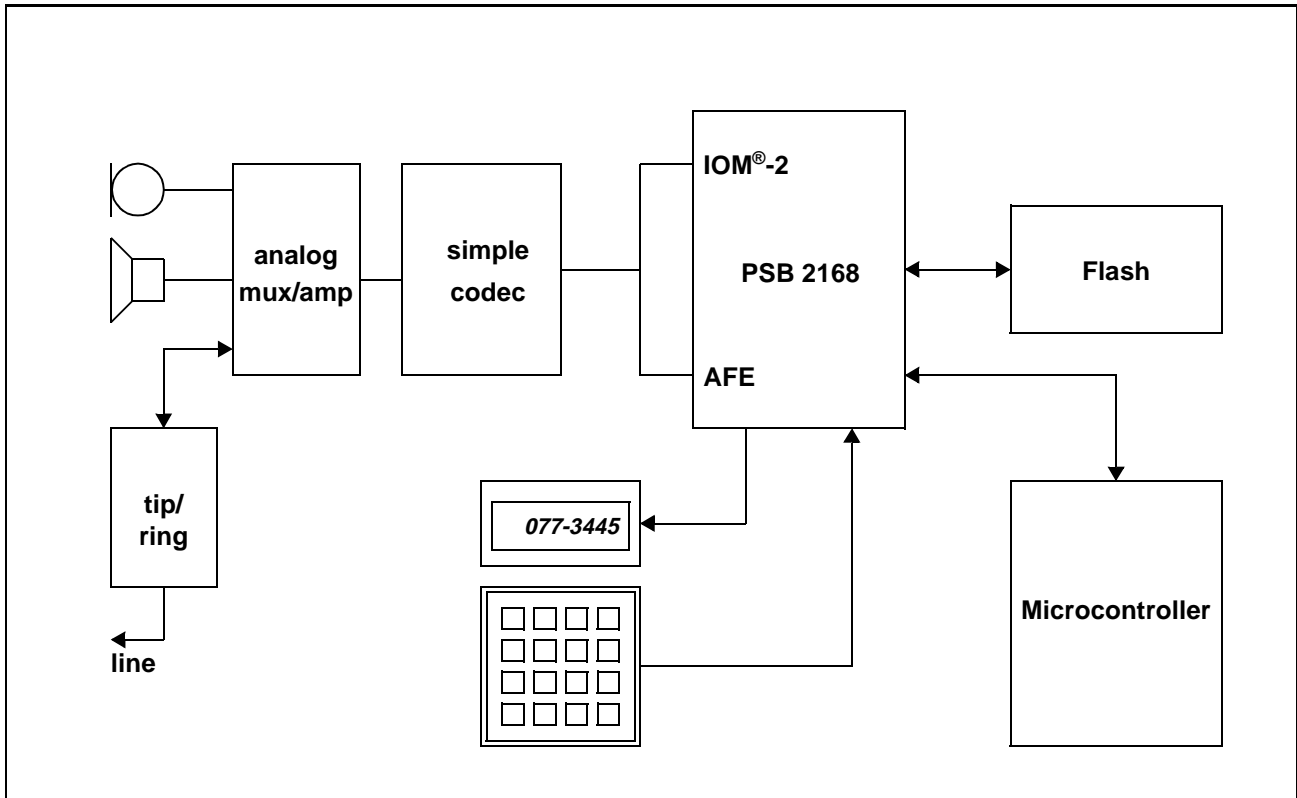

Figure 6 Stand-Alone Answering Machine with Flash Memory

In either case all features of the PSB 2168 can be used (e.g. caller id).

Functional Description

2 Functional Description

The PSB 2168 contains several functional units that can be combined with almost no restrictions to perform a given task. Figure 7 gives an overview of the important functional units.

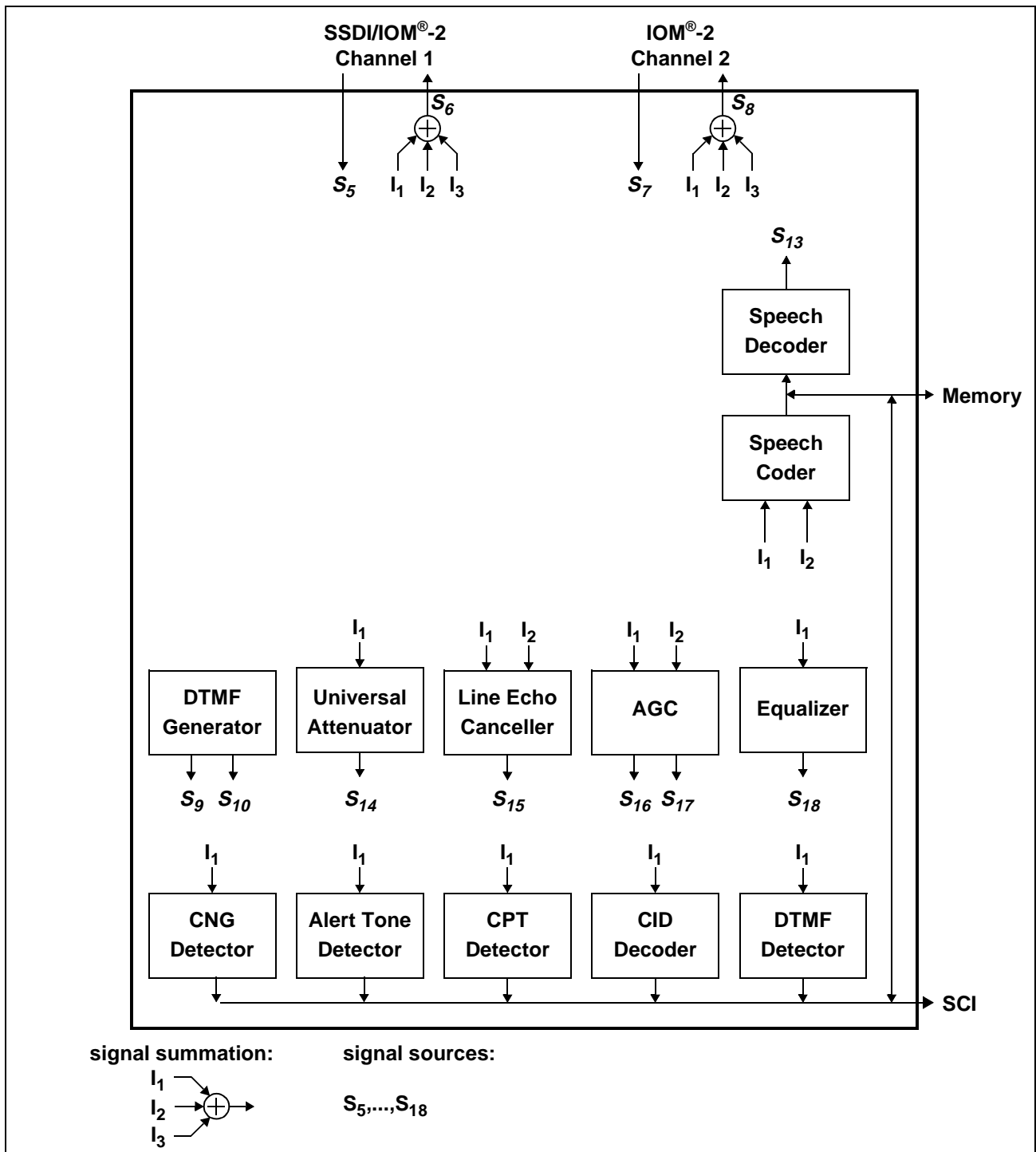

Figure 7 Functional Units - Overview

Functional Description

Each unit has one or more signal inputs (denoted by I). Most units have at least one signal output (denoted by S). Any input I can be connected to any signal output S. In addition to the signals shown in figure 7 there is also the signal S₀ (silence), which is useful at signal summation points. Table 2 lists the available signals within the PSB 2168 according to their reference points.

Table 2 Signal Summary

| Signal | Description |
|-----------------|---|
| S ₀ | Silence |
| S ₁ | Reserved |
| S ₂ | Reserved |
| S ₃ | Reserved |
| S ₄ | Reserved |
| S ₅ | Serial interface input, channel 1 |
| S ₆ | Serial interface output, channel 1 |
| S ₇ | Serial interface input, channel 2 |
| S ₈ | Serial interface output, channel 2 |
| S ₉ | DTMF generator output |
| S ₁₀ | DTMF generator auxiliary output |
| S ₁₁ | Reserved |
| S ₁₂ | Reserved |
| S ₁₃ | Speech decoder output |
| S ₁₄ | Universal attenuator output |
| S ₁₅ | Line echo canceller output |
| S ₁₆ | Automatic gain control output (after gain stage) |
| S ₁₇ | Automatic gain control output (before gain stage) |
| S ₁₈ | Equalizer output |

Functional Description

The following figures show the connections for a typical state during operation. Units that are not needed are not shown. Inputs that are not needed are connected to S_0 which provides silence (denoted by 0). In figure 8 a phone conversation is currently in progress. The speech coder is used to record the signals of both parties. The alert tone detector is used to detect an alerting tone of an off-hook caller id request while the CID decoder decodes the actual data transmitted in this case.

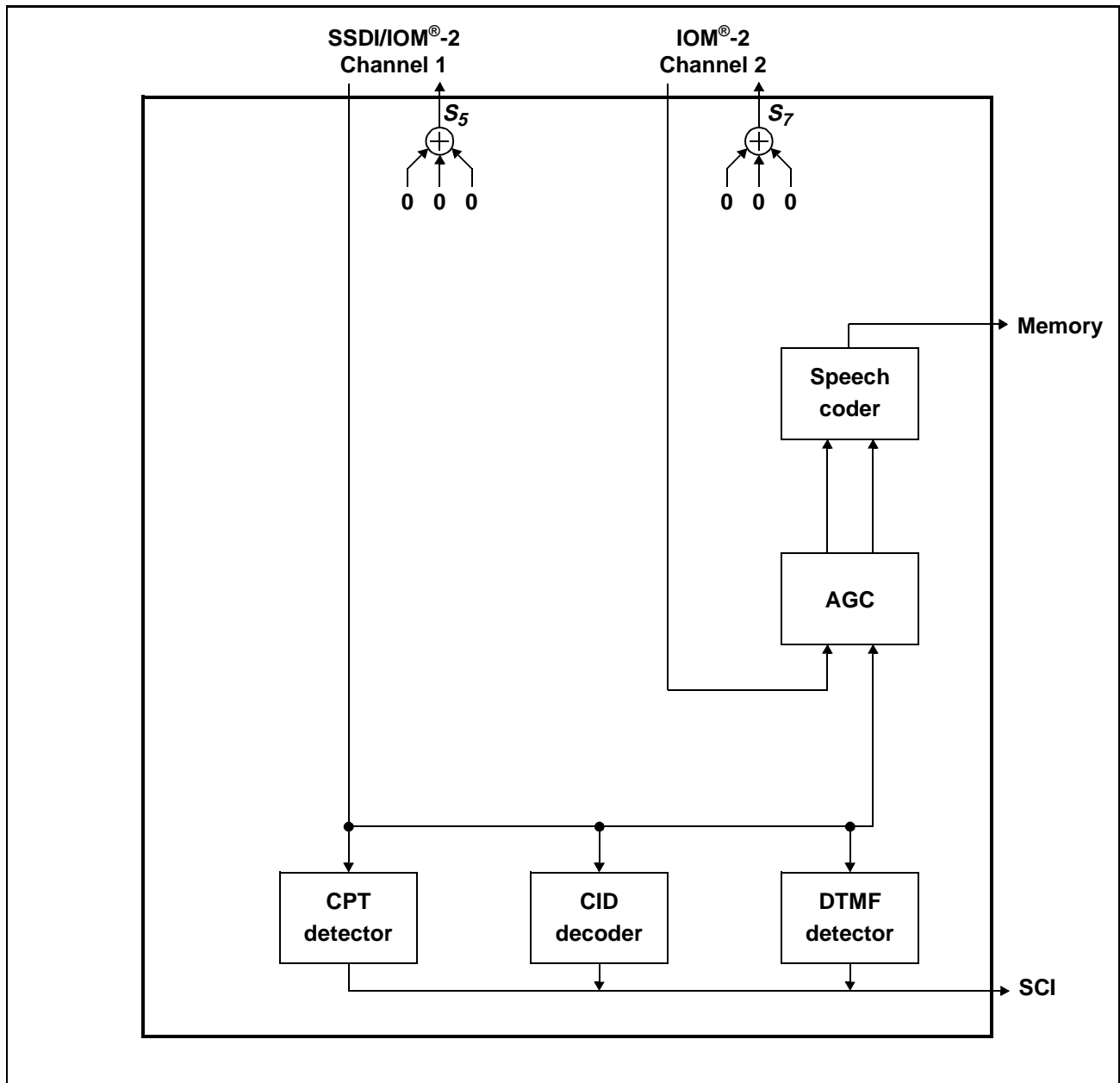

Figure 8 Functional Units - Recording a Phone Conversation

Functional Description

2.1 Functional Units

In this section the functional units of the PSB 2168 are described in detail. The functional units can be individually enabled or disabled.

2.1.1 Line Echo Canceller

The PSB 2168 contains an adaptive line echo cancellation unit for the cancellation of near end echoes. The unit has two modes: normal and extended. In normal mode, the maximum echo length is 4 ms. This mode is always available. In extended mode, the maximum echo length is 24 ms. Extended mode cannot be used while the speech encoder or slow playback is active.

The line echo cancellation unit is especially useful in front of the various detectors (DTMF, CPT, etc.). A block diagram is shown in figure 9.

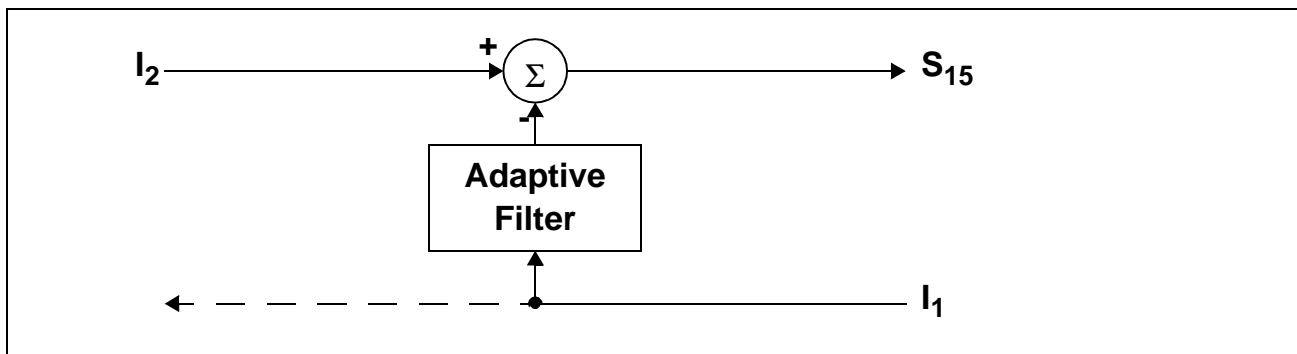

Figure 9 Line Echo Cancellation Unit - Block Diagram

The line echo canceller provides only one outgoing signal (S_{15}) as the other outgoing signal would be identical with the input signal I_1 .

Input I_2 is usually connected to the line input while input I_1 is connected to the outgoing signal.

In normal mode the adaption process can be controlled by three parameters: MIN, ATT and MGN. Adaption takes only place if both of the following conditions hold:

1. $I_1 > \text{MIN}$
2. $I_1 - I_2 - \text{ATT} + \text{MGN} > 0$

With the first condition adaption to small signals can be avoided. The second condition avoids adaption during double talk. The parameter ATT represents the echo loss provided by external circuitry. The adaption stops if the power of the received signal (I_2) exceeds the power of the expected signal ($I_1 - \text{ATT}$) by more than the margin MGN.

Functional Description

Table 3 shows the registers associated with the line echo canceller.

Table 3 Line Echo Cancellation Unit Registers

| Register | # of Bits | Name | Comment | Relevant Mode |
|----------|-----------|------|---|---------------|
| LECCTL | 1 | EN | Line echo canceller enable | both |
| LECCTL | 1 | MD | Line echo canceller mode | |
| LECCTL | 5 | I2 | Input signal selection for I ₂ | both |
| LECCTL | 5 | I1 | Input signal selection for I ₁ | both |
| LECLEV | 15 | MIN | Minimal power for signal I ₁ | normal |
| LECATT | 15 | ATT | Externally provided attenuation (I ₁ to I ₂) | normal |
| LECMGN | 15 | MGN | Margin for double talk detection | normal |

Functional Description

2.1.2 DTMF Detector

Figure 10 shows a block diagram of the DTMF detector. The results of the detector are available in the status register and a dedicated result register that can be read via the serial control interface (SCI) by the external controller. All sixteen standard DTMF tones are recognized.

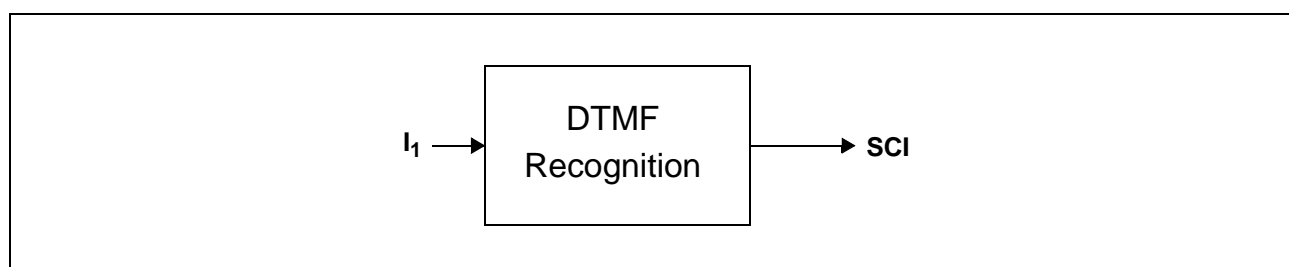

Figure 10 DTMF Detector - Block Diagram

Table 4 to 6 show the associated registers.

Table 4 DTMF Detector Control Register

| Register | # of Bits | Name | Comment |
|----------|-----------|------|------------------------|
| DDCTL | 1 | EN | DTMF detector enable |
| DDCTL | 5 | I1 | Input signal selection |

As soon as a valid DTMF tone is recognized, the status word and the DTMF tone code are updated (table 5).

Table 5 DTMF Detector Results

| Register | # of Bits | Name | Comment |
|----------|-----------|------|-----------------|
| STATUS | 1 | DTV | DTMF code valid |
| DDCTL | 5 | DTC | DTMF tone code |

DTV is set when a DTMF tone is recognized and reset when no DTMF tone is recognized or the detector is disabled. The code for the DTMF tone is placed into the register DDCTL. The registers DDTW and DDLEV hold parameters for detection (table 6).

Table 6 DTMF Detector Parameters

| Register | # of Bits | Name | Comment |
|----------|-----------|-------|---|
| DDTW | 15 | TWIST | Twist for DTMF recognition |
| DDLEV | 6 | MIN | Minimum signal level to detect DTMF tones |

Functional Description

2.1.3 CNG Detector

The calling tone (CNG) detector can detect the standard calling tones of fax machines or modems. This helps to distinguish voice messages from data transfers. The result of the detector is available in the status register that can be read via the serial control interface (SCI) by the external controller. The CNG detector consists of two band-pass filters with fixed center frequency of 1100 Hz and 1300 Hz.

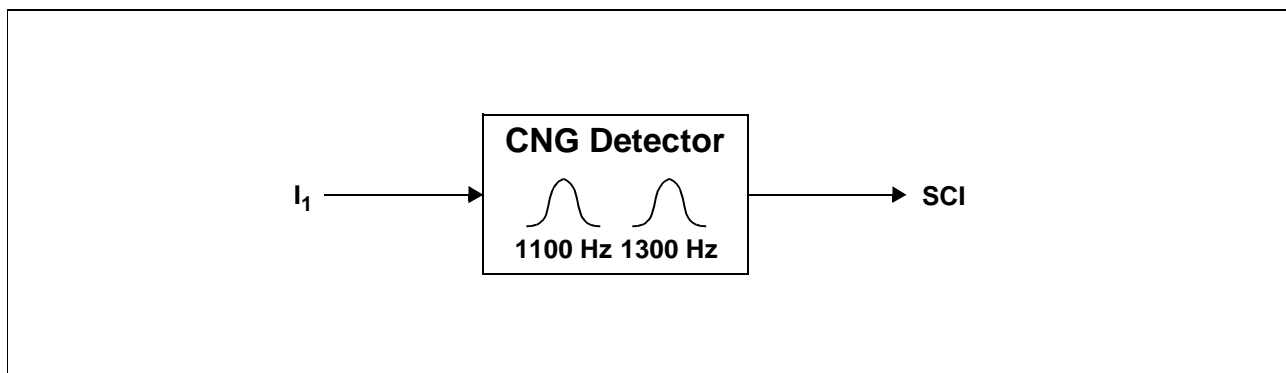

Figure 11 CNG Detector - Block Diagram

Table 7 shows the available parameters.

Table 7 CNG Detector Registers

| Register | # of Bits | Name | Comment |
|----------|-----------|------|------------------------------|
| CNGCTL | 1 | EN | CNG detector enable |
| CNGCTL | 5 | I1 | Input signal selection |
| CNGLEV | 16 | MIN | Minimum signal level |
| CNGBT | 16 | TIME | Minimum time of signal burst |
| CNGRES | 16 | RES | Input signal resolution |

Both the programmed minimum time and the minimum signal level must be exceeded for a valid CNG tone. Furthermore the input signal resolution can be reduced by the RES parameter. This can be useful in a noisy environment at low signal levels although the accuracy of the detection decreases. As soon as a valid tone is recognized, the status word of the PSB 2168 is updated. The status bits are defined as follows:

Table 8 CNG Detector Result

| Register | # of Bits | Name | Comment |
|----------|-----------|------|---------------------------------|
| STATUS | 1 | CNG | Fax/Modem calling tone detected |

2.1.4 Alert Tone Detector

The alert tone detector can detect the standard alert tones (2130 Hz and 2750 Hz) for caller id protocols. The results of the detector are available in the status register and the dedicated register ATDCTL0 that can be read via the serial control interface (SCI) by the external controller.

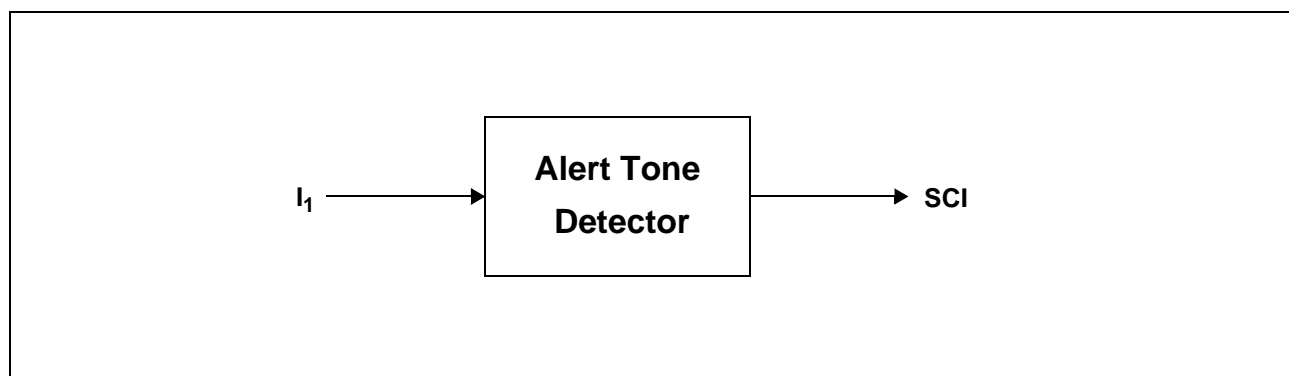

Figure 12 Alert Tone Detector - Block Diagram

Table 9 Alert Tone Detector Registers

| Register | # of Bits | Name | Comment |
|----------|-----------|------|--|
| ATDCTL0 | 1 | EN | Alert Tone Detector Enable |
| ATDCTL0 | 5 | I1 | Input signal selection |
| ATDCTL1 | 1 | MD | Detection of dual tones or single tones |
| ATDCTL1 | 1 | DEV | Maximum deviation (0.5% or 1.1%) |
| ATDCTL1 | 8 | MIN | Minimum signal level to detect alert tones |

As soon as a valid alert tone is recognized, the status word of the PSB 2168 and the code for the detected combination of alert tones are updated (table 10).

Table 10 Alert Tone Detector Results

| Register | # of Bits | Name | Comment |
|----------|-----------|------|---------------------|
| STATUS | 1 | ATV | Alert tone detected |
| ATDCTL0 | 2 | ATC | Alert tone code |

Functional Description

2.1.5 CPT Detector

The selected signal is monitored continuously for a call progress tone. The CPT detector consists of a band-pass and an optional timing checker (figure 13).

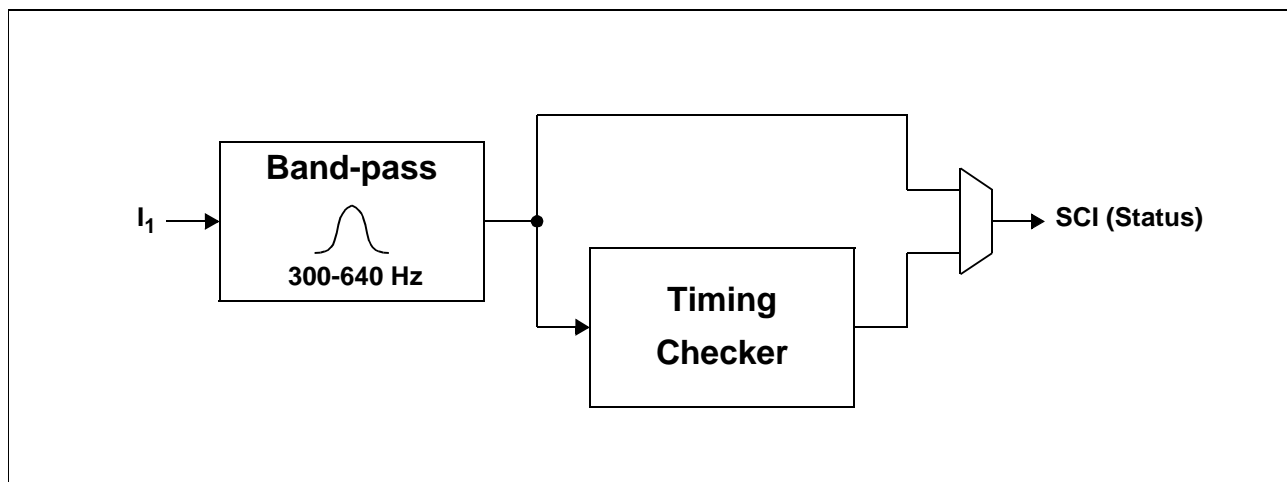

Figure 13 CPT Detector - Block Diagram

The CPT detector can be used in two modes: raw and cooked. In raw mode, the occurrence of a signal within the frequency range, time and energy limits is directly reported. The timing checker is bypassed and therefore the PSB 2168 does not interpret the length or interval of the signal.

In cooked mode, the number and duration of signal bursts are interpreted by the timing checker. A signal burst followed by a gap is called a cycle. Cooked mode requires a minimum of two cycles. The CPT flag is set with the first burst after the programmed number of cycles has been detected. The CPT flag remains set until the unit is disabled, even if the conditions are not met anymore. In this mode the CPT is modelled as a sequence of identical bursts separated by gaps with identical length. The PSB 2168 can be programmed to accept a range for both the burst and the gap. It is also possible to specify a maximum aberration of two consecutive bursts and gaps. Figure 14 shows the parameters for a single cycle (burst and gap).

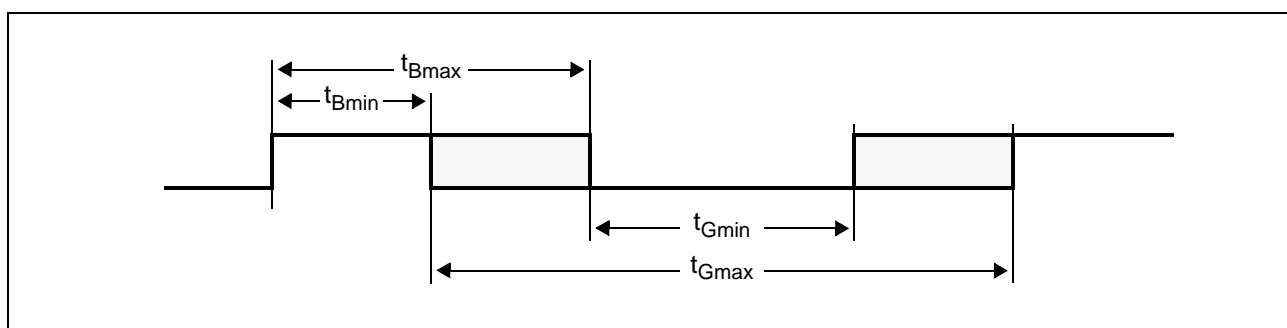

Figure 14 CPT Detector - Cooked Mode

The status bit is defined as follows:

Functional Description

Table 11 CPT Detector Result

| Register | # of Bits | Name | Comment |
|----------|-----------|------|---|
| STATUS | 1 | CPT | CP tone currently detected [340 Hz; 640 Hz] |

CPT is not affected by reading the status word. It is automatically reset when the unit is disabled. Table 12 shows the control register for the CPT detector.

Table 12 CPT Detector Registers

| Register | # of Bits | Name | Comment |
|----------|-----------|------|---|
| CPTCTL | 1 | EN | Unit enable |
| CPTCTL | 1 | MD | Mode (cooked, raw) |
| CPTCTL | 5 | I1 | Input signal selection |
| CPTMN | 8 | MINB | Minimum time of a signal burst (t_{Bmin}) |
| CPTMN | 8 | MING | Minimum time of a signal gap (t_{Gmin}) |
| CPTMX | 8 | MAXB | Maximum time of a signal burst (t_{Bmax}) |
| CPTMX | 8 | MAXG | Maximum time of a signal gap (t_{Gmax}) |
| CPTDT | 8 | DIFB | Maximum difference between consecutive bursts |
| CPTDT | 8 | DIFG | Maximum difference between consecutive gaps |
| CPTTR | 3 | NUM | Number of cycles (cooked mode), 0 (raw mode) |
| CPTTR | 8 | MIN | Minimum signal level to detect tones |
| CPTTR | 4 | SN | Minimal signal-to-noise ratio |

If any condition is violated during a sequence of cycles the timing checker is reset and restarts with the next valid burst.

Note: In cooked mode CPT is set with the first burst after the programmed number of cycles has been detected.

Note: The number of cycles must be set to zero in raw mode.

Functional Description

2.1.6 Caller ID Decoder

The caller ID decoder is basically a 1200 baud modem (FSK, demodulation only). The bit stream is formatted by a subsequent UART and the data is available in a data register along with status information (figure 15).

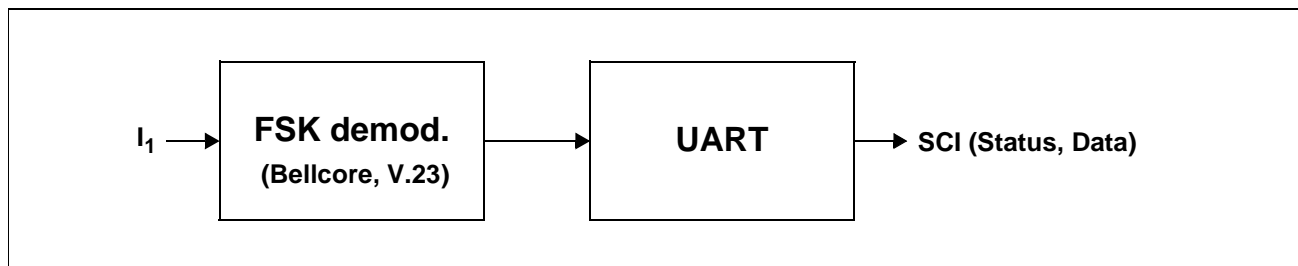

Figure 15 Caller ID Decoder - Block Diagram

The FSK demodulator supports two modes according to table 13. The appropriate mode is detected automatically.

Table 13 Caller ID Decoder Modes

| Mode | Mark (Hz) | Space (Hz) | Comment |
|------|-----------|------------|----------|
| 1 | 1200 | 2200 | Bellcore |
| 2 | 1300 | 2100 | V.23 |

The CID decoder does not interpret the data received. Each byte received is placed into the CIDCTL register (table 15). The status byte of the PSB 2168 is updated (table 14).

Table 14 Caller ID Decoder Status

| Register | # of Bits | Name | Comment |
|----------|-----------|------|-------------------|
| STATUS | 1 | CIA | CID byte received |
| STATUS | 1 | CD | Carrier Detected |

CIA and CD are cleared when the unit is disabled. In addition, CIA is cleared when CIDCTL0 is read.

Table 15 Caller ID Decoder Registers

| Register | # of Bits | Name | Comment |
|----------|-----------|------|-----------------------------|
| CIDCTL0 | 1 | EN | Unit enable |
| CIDCTL0 | 5 | I1 | Input signal selection |
| CIDCTL0 | 8 | DATA | Last CID data byte received |

Functional Description

Table 15 Caller ID Decoder Registers

| Register | # of Bits | Name | Comment |
|-----------------|------------------|-------------|---|
| CIDCTL1 | 5 | NMSS | Number of mark/space sequences necessary for successful detection of carrier detect |
| CIDCTL1 | 6 | NMB | Number of mark bits necessary before space of first byte after carrier detect |
| CIDCTL1 | 5 | MIN | Minimum signal level for CID detection |

When the CID unit is enabled, it first waits for a channel seizure signal consisting of a series of alternating space and mark signals. The number of spaces and marks that have to be received without errors before the PSB 2168 reports a carrier detect by setting status bit CD can be programmed.

Channel seizure must be followed by at least 16 continuous mark signals. The first space signal detected is then regarded as the start bit of the first message byte.

The interpretation of the data, including message type, length and checksum is completely left to the controller. The CID unit should be disabled as soon as the complete information has been received as it cannot detect the end of the transmission by itself.

Note: Some caller ID mechanism may require additional external components for DC decoupling. These tasks must be handled by the controller.

Note: The controller is responsible for selecting and storing parts of the CID as needed.

Functional Description

2.1.7 DTMF Generator

The DTMF generator can generate single or dual tones with programmable frequency and gain. This unit is primarily used to generate the common DTMF tones but can also be used for signalling or other user defined tones. A block diagram is shown in figure 16.

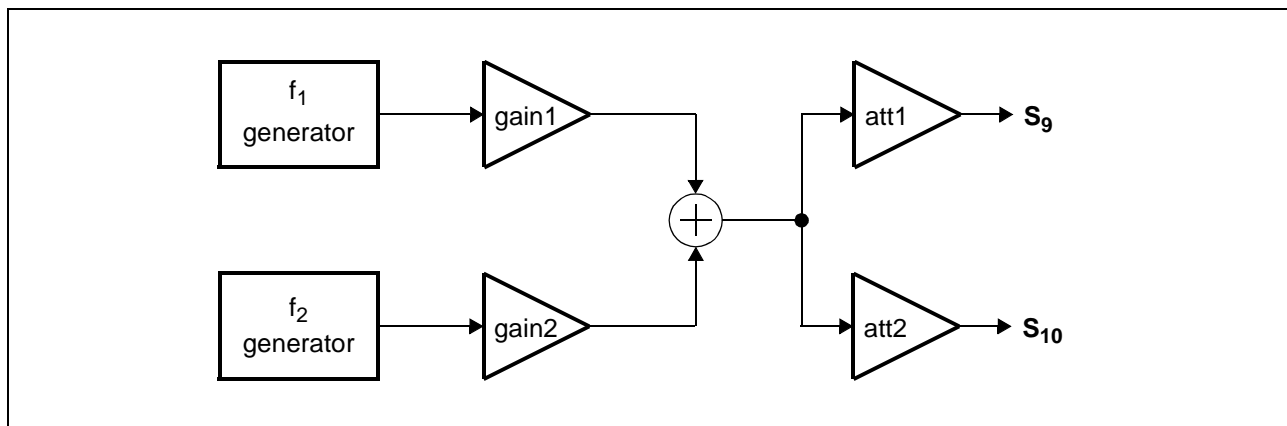

Figure 16 DTMF Generator - Block Diagram

Both generators and amplifiers are identical. There are two modes for programming the generators, cooked mode and raw mode. In cooked mode, the standard DTMF frequencies are generated by programming a single 4 bit code. In raw mode, the frequency of each generator/amplifier can be programmed individually by a separate register. The unit has two outputs which provide the same signal but with individually programmable attenuation. Table 16 shows the parameters of this unit.

Table 16 DTMF Generator Registers

| Register | # of Bits | Name | Comment |
|----------|-----------|------|---------------------------------|
| DGCTL | 1 | EN | Enable for generators |
| DGCTL | 1 | MD | Mode (cooked/raw) |
| DGCTL | 4 | DTC | DTMF code (cooked mode) |
| DGF1 | 15 | FRQ1 | Frequency of generator 1 |
| DGF2 | 15 | FRQ2 | Frequency of generator 2 |
| DGL | 7 | LEV1 | Level of signal for generator 1 |
| DGL | 7 | LEV2 | Level of signal for generator 2 |
| DGATT | 8 | ATT1 | Attenuation of S ₉ |
| DGATT | 8 | ATT2 | Attenuation of S ₁₀ |

Note: DGF1 and DGF2 are undefined when cooked mode is used and must not be written.

Functional Description

2.1.8 Speech Coder

The speech coder (figure 17) has two input signals I_1 and I_2 . The first signal (I_1) is fed to the coder while the second signal (I_2) is used as a reference signal for voice controlled recording. The signal I_1 can be coded by either a High Quality coder or a Long Play coder.

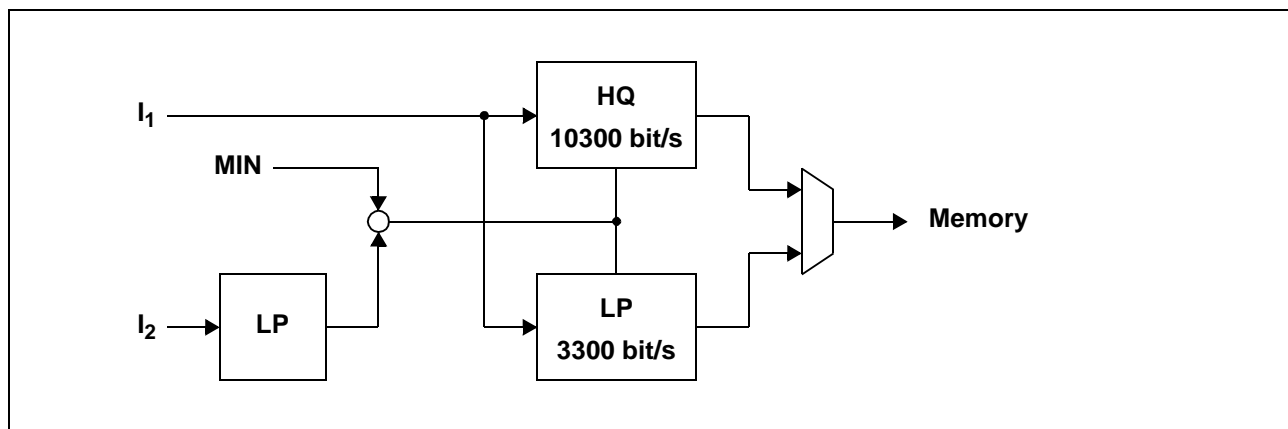

Figure 17 Speech Coder - Block Diagram

In High Quality the output data stream runs at a fixed rate of 10300 bit/s and provides excellent speech quality. In Long Play mode, the output data stream is further reduced to an average of 3300 bit/s while still maintaining good quality.

Data is written starting at the current file pointer and the file pointer is advanced as needed. In case of any memory error (e.g. memory full) a file error is indicated and the coder is disabled. The controller must subsequently close the file.

The coder can be switched on the fly. However, it may take up to 60 ms until the switch is executed. The controller must therefore wait for at least this time until issuing another command that relies on the mode switch. No audio data is lost during switching.

The signal I_2 is first filtered by a low pass LP1 with programmable time constant and then compared to a reference level MIN. If the filtered signal exceeds MIN, then the status bit SD (table 17) is set immediately. If the filtered signal has been smaller than MIN for a programmable time TIME then the status bit SD is reset.

The coder can be enabled in permanent mode or in voice recognition mode. In permanent mode, the coder starts immediately and compresses all input data continuously. The current state of the status bit SD does not affect the coder.

In voice recognition mode, the coder is automatically started on the first transition of the status bit from 0 to 1. Once the coder has started it remains active until disabled.

Table 17 Speech Coder Status

| Register | # of Bits | Name | Comment |
|----------|-----------|------|-----------------|
| STATUS | 1 | SD | Speech detected |

Functional Description

The operation of the speech coder is defined according to table 18.

Table 18 Speech Coder Registers

| Register | # of Bits | Name | Comment |
|----------|-----------|------|---|
| SCCTL | 1 | EN | Enable speech coder |
| SCCTL | 1 | HQ | High quality mode |
| SCCTL | 1 | VC | Voice controlled recording |
| SCCTL | 5 | I1 | Input signal 1 selection |
| SCCTL | 5 | I2 | Input signal 2 selection |
| SCCT2 | 8 | MIN | Minimal signal level for speech detection |
| SCCT2 | 8 | TIME | Minimum time for reset of SD |
| SCCT3 | 8 | LP | Time constant for low-pass |

Note: The peak data rate in LP mode is 4800 bit/s.

Note: Both HQ and LP mode will not produce identical bit streams after a coding/decoding cycle.

Functional Description

2.1.9 Speech Decoder

The speech decoder (figure 18) decompresses the data previously coded by the speech coder unit and delivers a standard 128 kbit/s data stream.

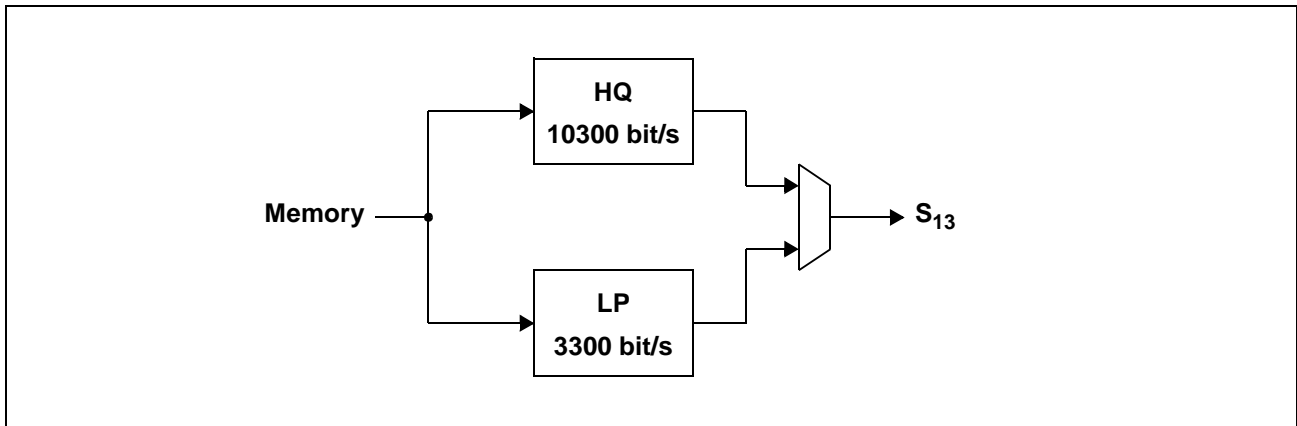

Figure 18 Speech Decoder - Block Diagram

The decoder supports fast (1.5 and 2.0 times) and slow (0.5 times) motion independent of the selected quality. The decoder requests input data as needed at a variable rate. Table 19 shows the signal and mode selection for the speech decoder.

Table 19 Speech Decoder Registers

| Register | # of Bits | Name | Comment |
|----------|-----------|-------|-----------------------------|
| SDCTL | 1 | EN | Enable speech decoder |
| SDCTL | 2 | SPEED | Selection of playback speed |

Data reading starts at the location of the current file pointer. The file pointer is updated during speech decoding. If the end of the file is reached, the decoder is automatically disabled. The PSB 2168 automatically resets SDCTL:EN at this point.

Functional Description

2.1.10 Digital Interface

There are two almost identical interfaces at the digital side as shown in figure 19. The only difference between these two interfaces is that only channel 1 supports the SSDI mode.

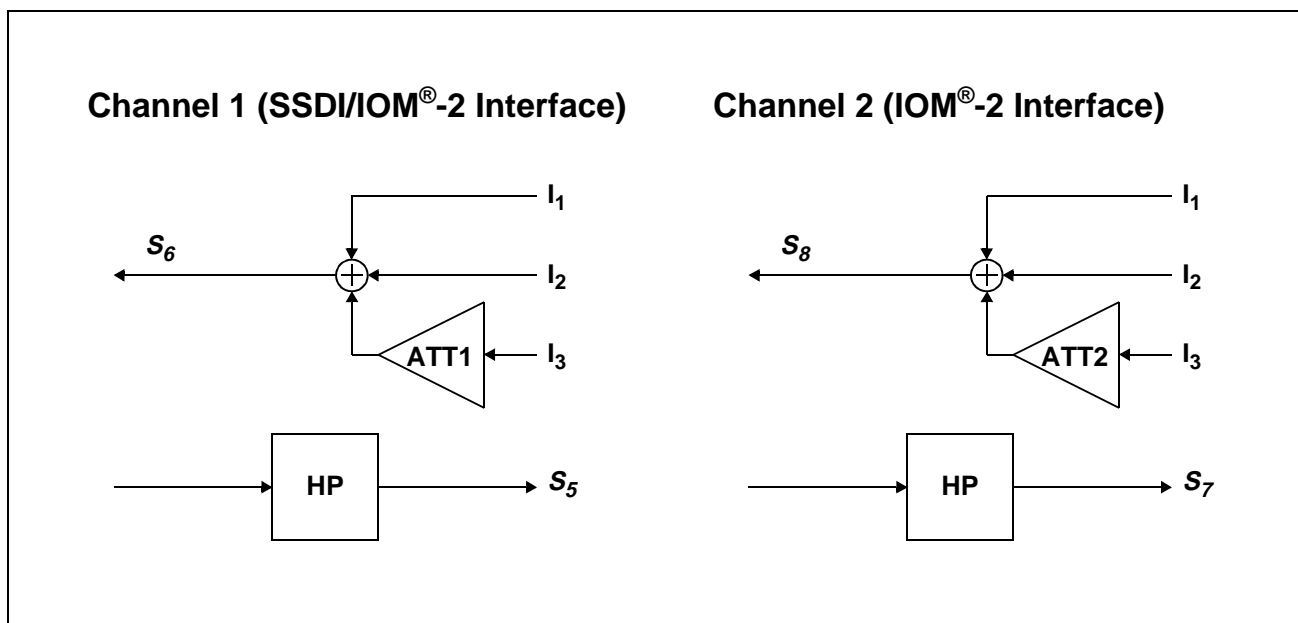

Figure 19 Digital Interface - Block Diagram

Each outgoing signal can be the sum of two signals with no attenuation and one signal with programmable attenuation (ATT). The attenuator can be used for artificial echo if there is none externally provided (e.g. ISDN application). Each input can be passed through an optional high-pass (HP). The associated registers are shown in table 20.

Table 20 Digital Interface Registers

| Register | # of Bits | Name | Comment |
|----------|-----------|------|-----------------------------------|
| IFS3 | 5 | I1 | Input signal 1 for S ₆ |
| IFS3 | 5 | I2 | Input signal 2 for S ₆ |
| IFS3 | 5 | I3 | Input signal 3 for S ₆ |
| IFS3 | 1 | HP | High-pass for S ₅ |
| IFS4 | 5 | I1 | Input signal 1 for S ₈ |
| IFS4 | 5 | I2 | Input signal 2 for S ₈ |
| IFS4 | 5 | I3 | Input signal 3 for S ₈ |
| IFS4 | 1 | HP | High-pass for S ₇ |

Functional Description**Table 20 Digital Interface Registers**

| Register | # of Bits | Name | Comment |
|-----------------|------------------|-------------|---|
| IFG5 | 8 | ATT1 | Attenuation for input signal I3 (Channel 1) |
| IFG5 | 8 | ATT2 | Attenuation for input signal I3 (Channel 2) |

Functional Description

2.1.11 Universal Attenuator

The PSB 2168 contains an universal attenuator that can be connected to any signal (e.g. for sidetone gain in ISDN applications).

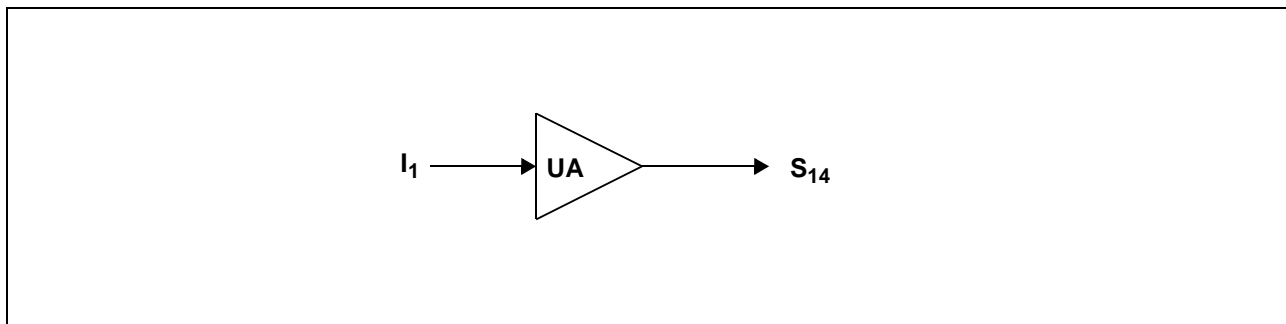

Figure 20 Universal Attenuator - Block Diagram

Table 21 shows the associated register.

Table 21 Universal Attenuator Registers

| Register | # of Bits | Name | Comment |
|----------|-----------|------|---------------------|
| UA | 8 | ATT | Attenuation for UA |
| UA | 5 | I1 | Input signal for UA |

Functional Description

2.1.12 Automatic Gain Control Unit

In addition to the universal attenuator with programmable but fixed gain the PSB 2168 contains an amplifier with automatic gain control (AGC). The AGC is preceded by a signal summation point for two input signals. One of the input signals can be attenuated.

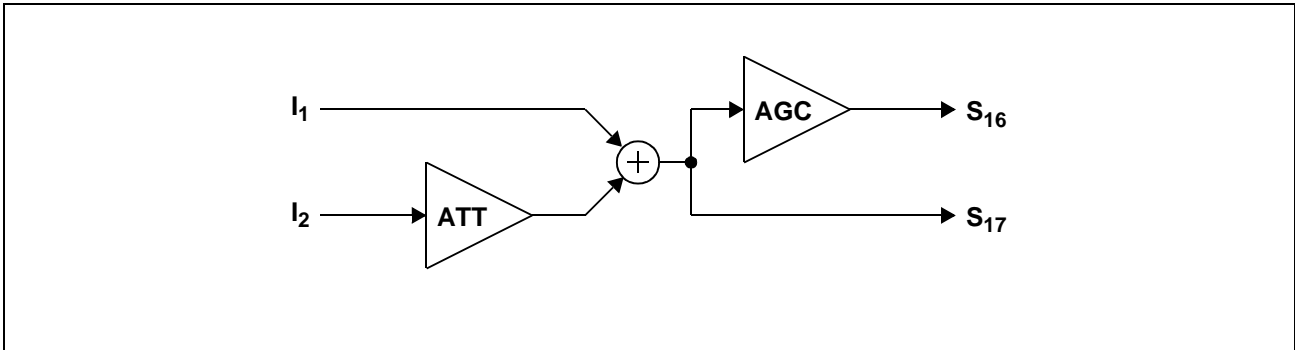

Figure 21 Automatic Gain Control Unit - Block Diagram

Furthermore the signal after the summation point is available. Besides providing a general signal summation (S_{16} not used) this signal is especially useful if the AGC unit provides the input signal for the speech coder. In this case S_{17} can be used as a reference signal for voice controlled recording.

Operation of the AGC depends on a threshold level defined by the parameter COM (value relative to the maximum PCM-value). The bold line in Figure 22 depicts the steady-state output level of the AGC as a function of the input level.

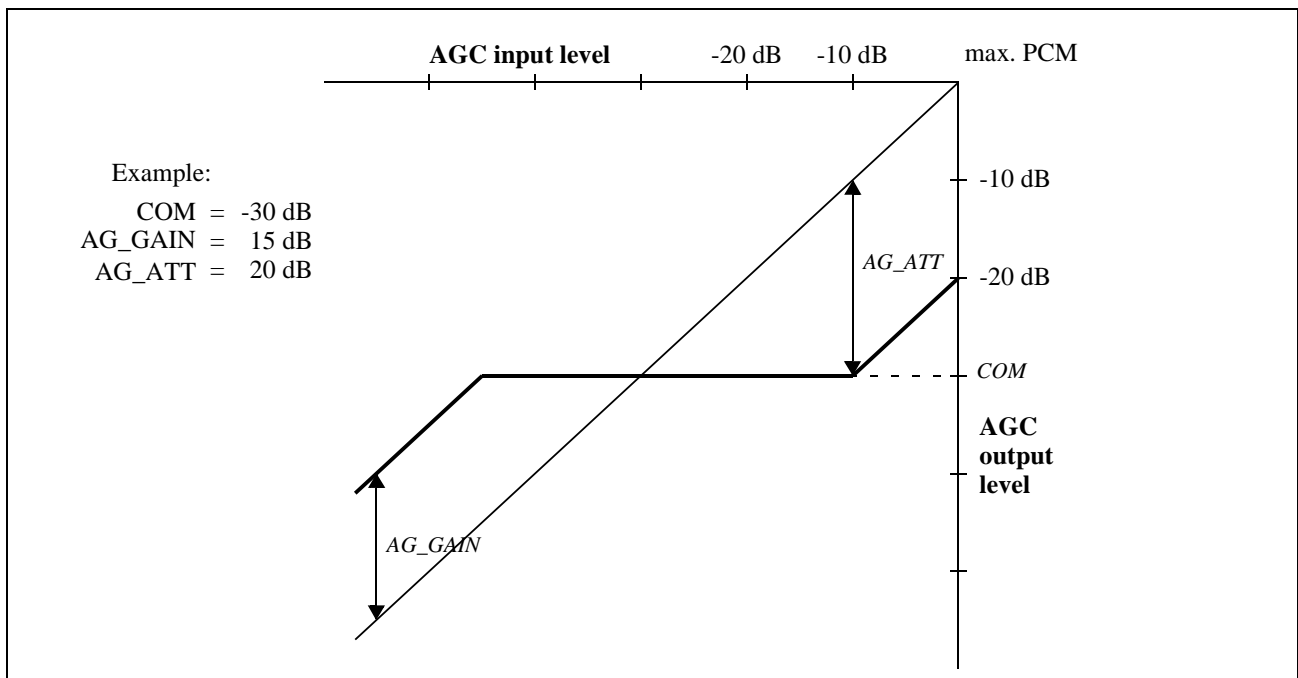

Figure 22 Automatic Gain Control Unit - Steady State Characteristic

Functional Description

The regulation speed is controlled by SPEEDH for signal amplitudes above the threshold and SPEEDL for amplitudes below. Usually SPEEDH will be chosen to be at least 10 times faster than SPEEDL. The AGC reacts faster for higher values of SPEEDH (SPEEDL). The current gain/attenuation of the AGC can be read at any time. An additional low pass with time constant LP is provided to avoid an immediate response of the AGC to very short signal bursts.

Furthermore the AGC contains a comparator that starts and stops the gain regulation. The signal after the summation point (S17) is filtered by a peak detector with time constant DEC for decay. Then the signal is compared to a programmable limit LIM. Regulation takes only place when the filtered signal exceeds the limit.

Table 22 shows the associated registers.

Table 22 Automatic Gain Control Registers

| Register | # of Bits | Name | Comment |
|----------|-----------|---------|--------------------------------------|
| AGCCTL | 1 | EN | Enable |
| AGCCTL | 5 | I1 | Input signal 1 for AGC |
| AGCCTL | 5 | I2 | Input signal 2 for AGC |
| AGCATT | 15 | ATT | Attenuation for I ₂ |
| AGC1 | 8 | AG_INIT | Initial AGC gain/attenuation |
| AGC1 | 8 | COM | Compare level rel. to max. PCM-value |
| AGC2 | 8 | SPEEDL | Change rate for lower levels |
| AGC2 | 8 | SPEEDH | Change rate for higher level |
| AGC3 | 8 | AG_ATT | Attenuation range |
| AGC3 | 7 | AG_GAIN | Gain range |
| AGC4 | 7 | DEC | Peak detector time constant |
| AGC4 | 8 | LIM | Comparator minimal signal level |
| AGC5 | 7 | LP | AGC low pass time constant |

Functional Description

2.1.13 Equalizer

The PSB 2168 also provides an equalizer that can be inserted into any signal path. The main application for the equalizer is the adaption to the frequency characteristics of the microphone, transducer or loudspeaker.

The equalizer consists of an IIR filter followed by an FIR filter as shown in figure 23.

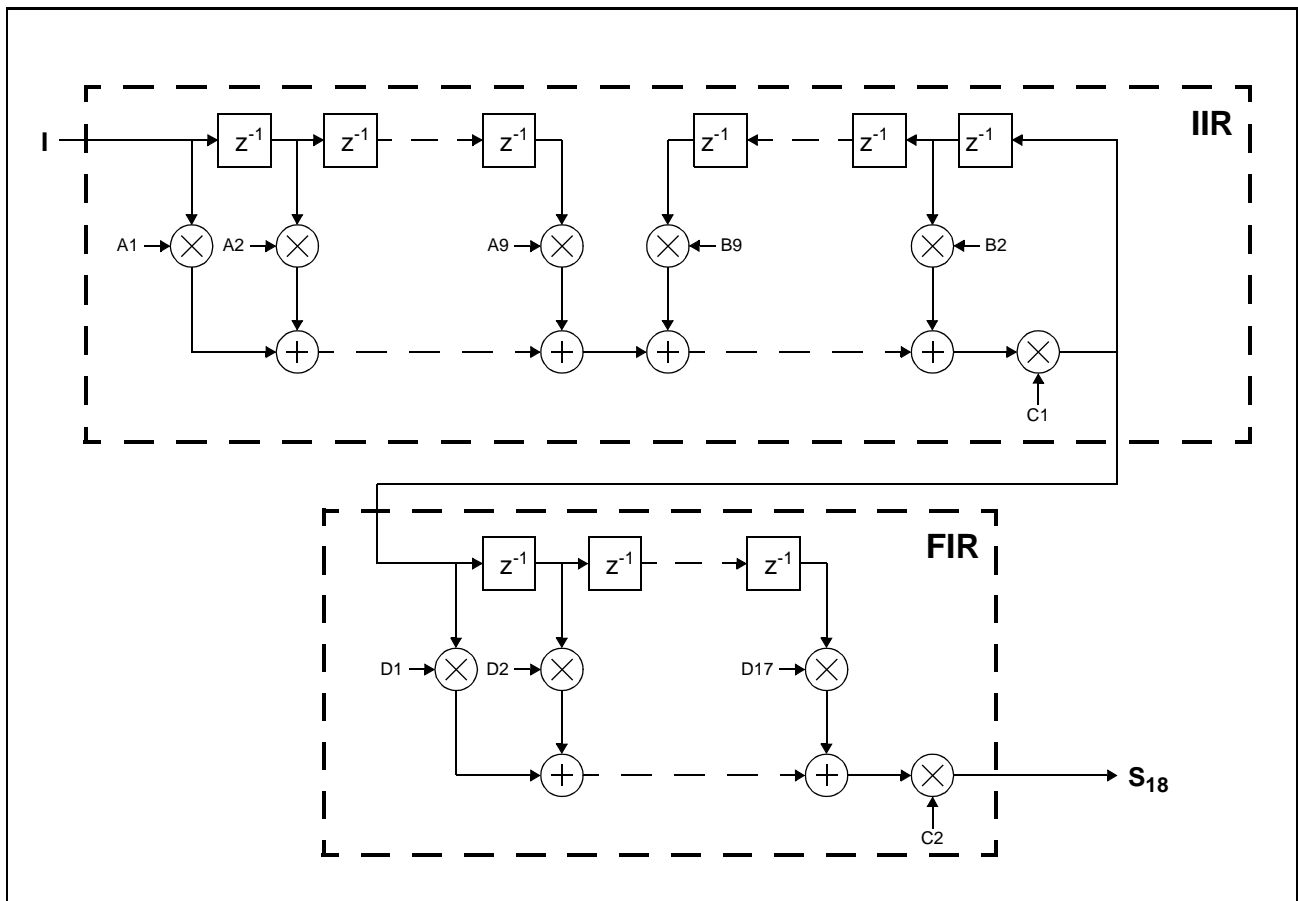

Figure 23 Equalizer - Block Diagram

The coefficients A_1 - A_9 , B_2 - B_9 and C_1 belong to the IIR filter, the coefficients D_1 - D_{17} and C_2 belong to the FIR filter. Table 23 shows the registers associated with the equalizer.

Table 23 Equalizer Registers

| Register | # of Bits | Name | Comment |
|----------|-----------|------|----------------------------|
| FCFCTL | 1 | EN | Enable |
| FCFCTL | 5 | I | Input signal for equalizer |
| FCFCTL | 6 | ADR | Filter coefficient address |
| FCFCOF | 16 | | Filter coefficient data |

Functional Description

Due to the multitude of coefficients the PSB 2168 uses an indirect addressing scheme for reading or writing an individual coefficient. The address of the coefficient is given by ADR and the actual value is read or written to register FCFCOF.

In order to ease programming the PSB 2168 automatically increments the address ADR after each access to FCFCOF.

Note: Any access to an out-of-range address automatically resets FCFCTL:ADR.

2.2 Memory Management

This section describes the memory management provided by the PSB 2168. As figure 24 shows, three units can access the external memory. During recording, the speech coder can write compressed speech data into the external memory. For playback, the speech decoder reads compressed speech data from external memory. In addition, the microcontroller can directly access the memory by the SCI interface.

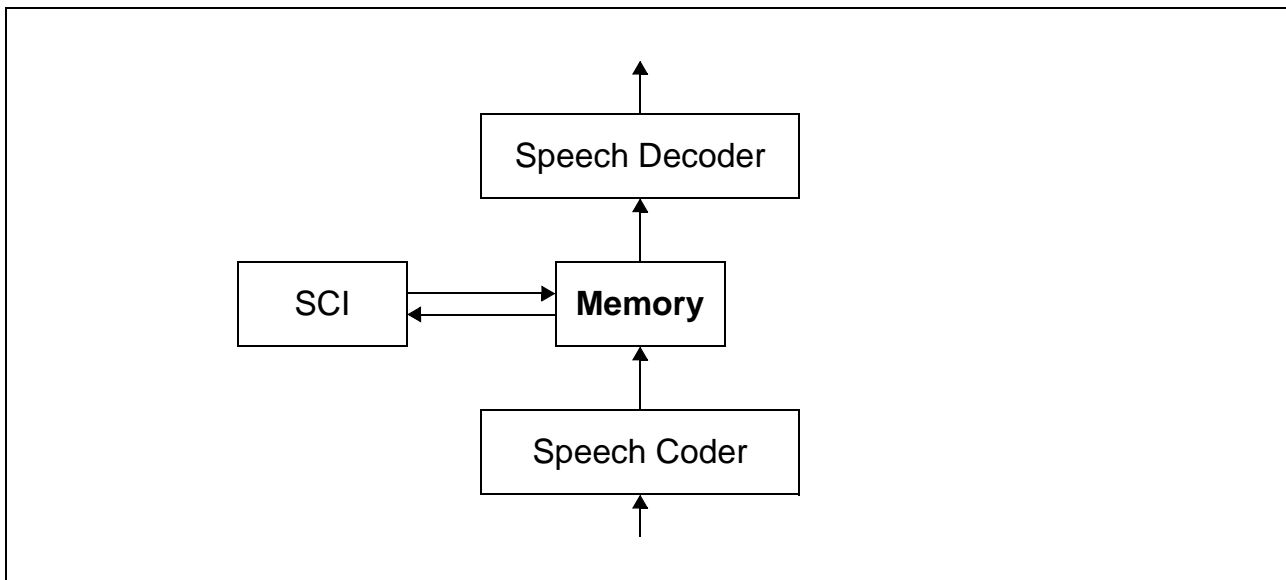

Figure 24 Memory Management - Data Flow

The memory is organized as a file system. For each memory space (R/W-memory and voice prompt memory) the PSB 2168 maintains a directory with 255 file descriptors (figure 25).

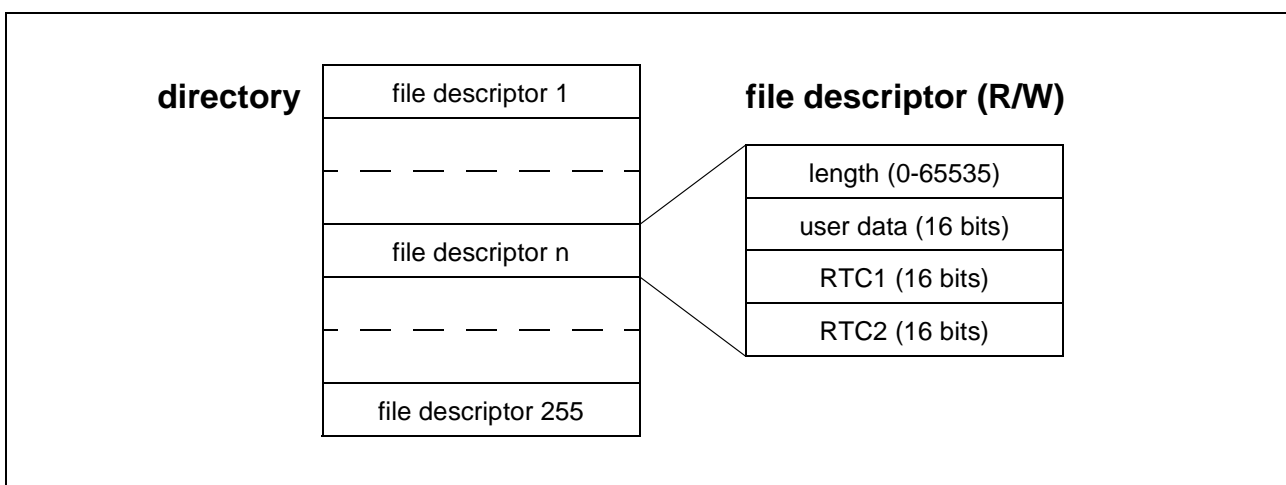

Figure 25 Memory Management - Directory Structure

The directories must be created after each power failure for volatile R/W-memory. All file descriptors are cleared (all words zero). For non-volatile memory, the directories have to

Functional Description

be created only once. If the directories already exist, the memory has just to be activated after a reset. The file descriptors are not changed in this case.

All commands that access the other fields or involve a write access must not be used in voice prompt memory space.

2.2.1 File Definition and Access

A file is a linear sequence of units and can be accessed in two modes: binary and audio. In binary mode, a unit is a word. In audio mode, a unit is a variable number of words representing 30 ms of uncompressed speech. A file can contain at most 65535 units. Figure 26 shows an audio file containing 100 audio units. The length of the message is therefore 3 s.

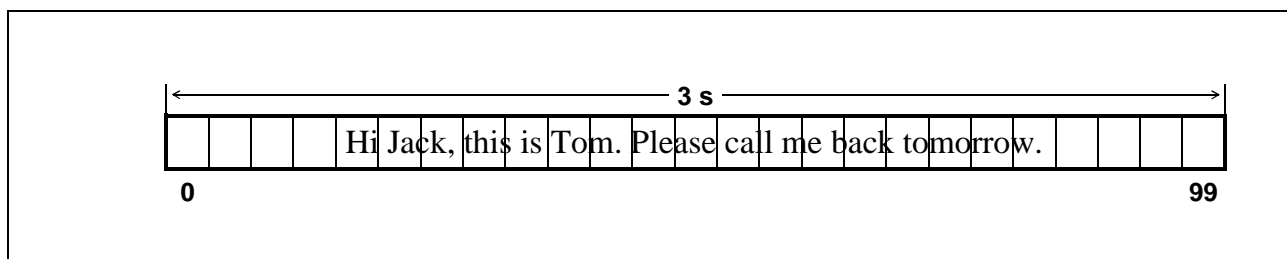

Figure 26 Audio File Organization - Example

Figure 27 shows a binary file of 11 words containing a phonebook (with only two entries).

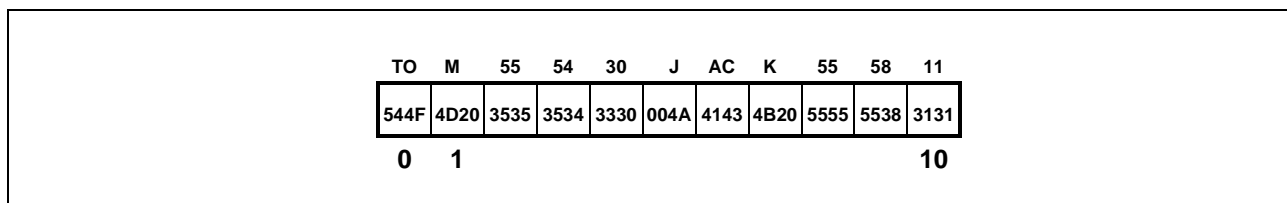

Figure 27 Binary File Organization - Example

There is one special file in the voice prompt directory (referenced by file number 255) which is intended for a large number of phrases and hence has a different organization. This file exists only in the directory for the voice prompt memory. It consists of up to 2048 phrases of arbitrary individual length. The actual number of units within an individual phrase is determined during creation and cannot be altered afterwards. Phrases can be combined in any sequence without intermediate noise or gaps.

Functional Description

Figure 28 shows a phrase file containing a total of five phrases.

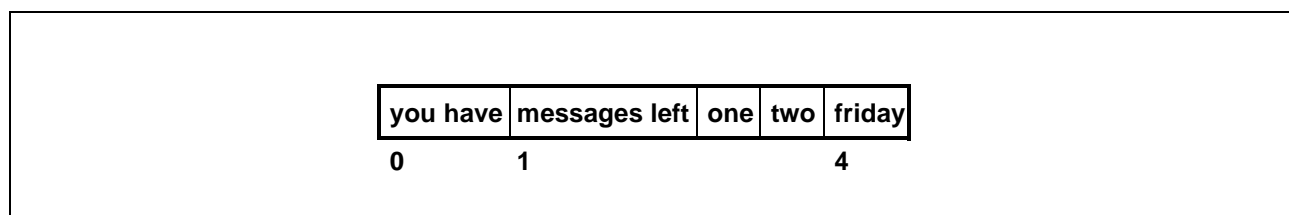

Figure 28 Phrase File Organization - Example

Before an access to a file can take place, the file must be opened with the following information:

1. memory space (messages or voice prompts)
2. file number
3. access mode

These parameters remain effective until the next open command is given or, in case of the file pointer, until a file access. All other files are closed and cannot be accessed. The file with file number 0 is not a physical file. Opening this file closes all physical files.

The PSB 2168 provides four registers for file access and two bits within the STATUS register. Table 24 shows these registers.

Table 24 Memory Management Registers

| Register | # of Bits | Comment |
|----------|-----------|---|
| FCMD | 16 | Command to execute |
| FCTL | 16 | Access mode and file number |
| FDATA | 16 | Data transfer and additional parameters |
| FPTR | 16 (11) | File pointer (phrase selector) |
| STATUS | 16 | Busy and Error indication |

The status register contains two flags (table 25) to indicate if currently a file command is under execution and if the last file command terminated without error. A new command must not be written to FCMD while the last one is still running (STATUS:BSY=1). The only command that can be aborted is Compress File.

Table 25 Memory Management Status

| Register | # of Bits | Name | Comment |
|----------|-----------|------|---|
| STATUS | 1 | BSY | File command or decoder/encoder still running |
| STATUS | 1 | ERR | File command completed/aborted with error |

Functional Description

Writing to FCMD also resets the error bit in the status register.

Table 26 shows the parameters defining the access mode and the access location. All parameters can only be written when no file command is currently running. They become effective after the completion of an open command. If another unit (e.g. speech coder) accesses the file, the file pointer is updated automatically. Therefore the controller can monitor the progress of recording or playing by reading the file pointer.

Table 26 Memory Management Parameters

| Register | # of Bits | Name | Comment |
|----------|-----------|------|------------------------------------|
| FCTL | 1 | MS | Memory space (R/W or voice prompt) |
| FCTL | 1 | MD | Access mode (audio or binary) |
| FCTL | 1 | TS | Write timestamp (file open only) |
| FCTL | 8 | FNO | File number (active file) |
| FPTR | 16 | | File pointer or phrase selector |

Commands are written to the FCMD register. The busy bit in the STATUS register is set within 125µs. The command may start execution after a delay, however (see section 2.2.5). Some commands require additional parameters which are written prior to the command into the specified registers. Data transfer is done by the register FDATA (both reading and writing).

2.2.2 User Data Word

The user data word consists of 12 bits that can be read or written by the user, two bits (R) that are reserved for future use and two read-only bits (D,M) which indicate the status of a file.

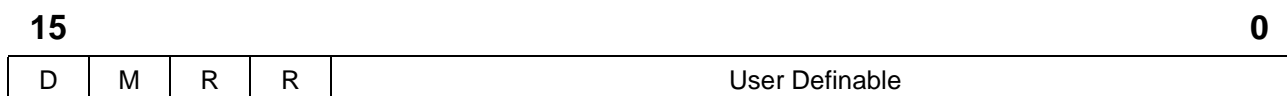

If D is set, the file is marked for deletion and should not be used any more. This bit is maintained by the PSB 2168 for housekeeping.

Functional Description

2.2.3 High Level Memory Management Commands

This section describes each of the high level memory management commands in detail. These commands are sufficient for normal operation of an answering machine. In addition, there are four low level commands (section 2.2.4). These commands are only required for special tasks like in-system reprogramming of the voice prompt area.

2.2.3.1 Initialize

This command creates a directory, sets the external memory configuration and delivers the size of usable memory in 1 kByte blocks. Furthermore the voice prompt memory space is scanned for a valid directory. The PSB 2168 can either create an empty directory from scratch or leave the first n files of an existing directory untouched while deleting the remaining files (ARAM/DRAM only). This option is useful if due to an unexpected event (e.g. power loss during recording) some data is corrupted. In that case vital system information can still be recovered if it has been stored in the first files.

Table 27 Initialize Memory Parameters

| Register | # of Bits | Name | Comment |
|----------|-----------|------|--|
| FCMD | 5 | CMD | Initialize command code |
| FCMD | 1 | IN | Confirmation for Initialization |
| FCTL | 8 | FNO | 0: delete no file 1: delete all files n: delete starting with file n |
| CCTL | 2 | MT | Type of R/W memory (DRAM, Flash) |
| CCTL | 1 | MQ | Quality of R/W memory (Audio, Normal) |
| CCTL | 1 | MV | Scan for voice prompt directory |

Table 28 Initialize Memory Results

| Register | # of Bits | Name | Comment |
|----------|-----------|------|--|
| FDATA | 16 | | Number of usable 1kByte blocks in R/W memory |

Possible Errors:

- no R/W memory found
- more than 59 bad blocks (flash and ARAM)
- voice prompt directory requested, but not detected

Note: This command must be given only once for flash devices.

Functional Description

2.2.3.2 Activate

This command activates an existing directory, sets the external memory configuration and delivers the size of usable memory in 1 kByte blocks. Furthermore the voice prompt memory space is scanned for a valid directory. Upon activation the PSB 2168 checks (in case of ARAM/DRAM only) the consistency of the directory in R/W memory space. It returns the first file that contains corrupted data (if any). If corrupted data is detected an initialization should be performed with the same file number as an input parameter.

Table 29 Activate Memory Parameters

| Register | # of Bits | Name | Comment |
|----------|-----------|------|---------------------------------------|
| FCMD | 5 | CMD | Activate command code |
| CCTL | 2 | MT | Type of R/W memory (DRAM, Flash) |
| CCTL | 1 | MQ | Quality of R/W memory (Audio, Normal) |
| CCTL | 1 | MV | Voice prompt directory available |

Table 30 Activate Memory Results

| Register | # of Bits | Name | Comment |
|----------|-----------|------|---|
| FDATA | 16 | | Number of usable 1 kByte blocks in R/W memory |
| FCTL | 8 | FNO | n: number of first corrupted file |

Possible error conditions:

- no memory connected
- no directory found
- device ID wrong (flash only)
- corrupted files found (see FCTL:FNO)
- directory corrupted

This command can have three types of result as shown in table 31.

Table 31 Activate Memory Result Interpretation

| Result | STATUS: ERR | FCTL: FNO | Comment |
|------------|----------------|--------------|---|
| no error | 0 | 0 | Command successful, memory activated. |
| soft error | 1 | n | The first n-1 files are O.K. The memory is activated. |
| hard error | 1 | 1 | The memory is not activated due to a hard error. |

Functional Description

2.2.3.3 Open File

A specific file is opened for subsequent accesses with the specified access mode. Opening a new file automatically closes the currently open file and clears the file pointer. Opening file number 0 can be used to close all physical files. If the TS flag is set, the current content of RTC1 and RTC2 is written to the appropriate fields of the file descriptor in order to provide a timestamp.

Table 32 Open File Parameters

| Register | # of Bits | Name | Comment |
|----------|-----------|------|----------------------------------|
| FCMD | 5 | CMD | Open command code |
| FCTL | 1 | MS | Memory space (R/W, voice prompt) |
| FCTL | 1 | MD | Access mode (audio or binary) |
| FCTL | 1 | TS | Write timestamp |
| FCTL | 8 | FNO | File number <fno> |

Possible error conditions:

- selected file marked for deletion, but not yet deleted by garbage collection
- memory space invalid
- new file selected, but memory full
- <fno> exceeds number of prompts (in voice prompt space only)
- wrong access mode selected for existing file

Note: In case of flash memory existing ones in the entries RTC1/RTC2 of the file descriptor cannot be altered. Therefore TS should be set only once during the lifetime of a file.

2.2.3.4 Open Next Free File

The next free file is opened for subsequent write accesses with the specified access mode. The search starts at the specified file number. If the TS flag is set, the current content of RTC1 and RTC2 is written to the appropriate fields of the file descriptor in order to provide a timestamp. If a free file has been found, the file is opened and the file number is returned in FCTL:FNO. Otherwise an error is reported.

Table 33 Open Next Free File Parameters

| Register | # of Bits | Name | Comment |
|----------|-----------|------|----------------------------------|
| FCMD | 5 | CMD | Open Next Free File command code |
| FCTL | 1 | MD | Access mode (audio or binary) |

Functional Description

Table 33 Open Next Free File Parameters

| Register | # of Bits | Name | Comment |
|----------|-----------|------|---------------------|
| FCTL | 1 | TS | Write timestamp |
| FCTL | 8 | FNO | Starting point (>0) |

Table 34 Open Next Free File Results

| Register | # of Bits | Name | Comment |
|----------|-----------|------|-------------|
| FCTL | 8 | FNO | File number |

Possible error conditions:

- no unused file found
- memory full

Note: In case of flash memory existing ones cannot be altered. Therefore TS should be set only once during the lifetime of a file.

Note: R/W-memory must be selected (FCTL:MS). Otherwise the result is unpredictable.

2.2.3.5 Seek

The file pointer of the currently opened file is set to the specified position. If the current file is the phrase file the PSB 2168 starts the speech decoder immediately after the seek is finished. This is done by simply enabling the decoder. All other settings of the decoder remain unaffected. The BSY bit is first set during the file command. It is then reset for a short period until the speech decoder is enabled internally. It is then set again while the decoder is running and finally reset when the phrase is finished.

Table 35 Seek Parameters

| Register | # of Bits | Name | Comment |
|----------|-----------|------|--------------------------------|
| FCMD | 5 | CMD | Seek command code |
| FPTR | 16 (11) | | File pointer (phrase selector) |

Possible error conditions:

- file pointer out of range
- phrase number out of range

Functional Description

2.2.3.6 Cut File

All units starting with the unit addressed by the file pointer are removed from the file. If all units are deleted the file is marked for deletion (see user data word). However, the associated file descriptor and memory space are released only after a subsequent garbage collection.

Table 36 Cut File Parameters

| Register | # of Bits | Name | Comment |
|----------|-----------|------|----------------------------------|
| FCMD | 5 | CMD | Cut command code |
| FPTR | 16 | | Position of first unit to delete |

Possible error conditions:

- file pointer out of range
- voice prompt memory selected

2.2.3.7 Compress File

An audio file that has been recorded in HQ mode can be recoded using LP mode. This reduces the file size to approximately one third of the original size. The speech quality, however, is somewhat lower compared to a signal that has been recorded in LP mode in the first place. This command can be aborted at any time and resumed later without loss of information. Prior to this command all files must be closed. Table 37 shows the parameters for this command.

Table 37 Compress File Parameters

| Register | # of Bits | Name | Comment |
|----------|-----------|------|-----------------------|
| FCMD | 5 | CMD | Compress command code |
| FCTL | 8 | FNO | File number <fno> |

Possible error conditions:

- <fno> invalid
- another file currently open
- binary file selected

Functional Description
2.2.3.8 Memory Status

This command returns the number of available 1 kB blocks in R/W memory space.

Table 38 Memory Status Parameters

| Register | # of Bits | Name | Comment |
|----------|-----------|------|--------------------|
| FCMD | 5 | CMD | Memory status code |

Table 39 Memory Status Results

| Register | # of Bits | Name | Comment |
|----------|-----------|------|-----------------------|
| FDATA | 16 | FREE | Number of free blocks |

Possible error conditions:

- file open

2.2.3.9 Garbage Collection

This command initiates a garbage collection. Until a garbage collection files that are marked for deletion still occupy the associated file descriptor and memory space. After the garbage collection these file descriptors and the associated memory space are available again. This command can optionally remap the directory. In this mode the remaining file descriptors are remapped to form a contiguous block starting with file number 1. The original order is preserved. This command requires that all files are closed, i.e. file 0 is opened. Independently of the selected directory only the read/write directory is used.

Table 40 Garbage Collection Parameters

| Register | # of Bits | Name | Comment |
|----------|-----------|------|---------------------------------|
| FCMD | 5 | CMD | Garbage Collection Command Code |
| FCMD | 1 | RD | Remap Directory |

Possible error conditions:

- file open

2.2.3.10 Access File Descriptor

By this command the length, user data word and RTC1/RTC2 of a file descriptor can be read. The user data word can also be written. The file or the other entries of the file descriptor are not affected by this command.

Functional Description

Table 41 Access File Descriptor Parameters

| Register | # of Bits | Name | Comment |
|----------|-----------|------|--|
| FCMD | 5 | CMD | Read Access or Write Access command code |
| FDATA | 16 | | User data (write access only) |

Table 42 Access File Descriptor Results

| Register | # of Bits | Name | Comment |
|----------|-----------|------|--|
| FDATA | 16 | | Content of selected entry (read access only) |

Possible error conditions:

- none

Note: In case of flash memory bits already set to 1 cannot be altered.

Note: Do not use this command with the phrase file (fno = 255).

2.2.3.11 Read Data

This command can be used in binary access mode only. A single word is read at the position given by the file pointer. The file pointer can be set by the Seek command. The file pointer is advanced by one word automatically.

Table 43 Read Data Parameters

| Register | # of Bits | Name | Comment |
|----------|-----------|------|------------------------|
| FCMD | 5 | CMD | Read Data Command Code |

Table 44 Read Data Results

| Register | # of Bits | Name | Comment |
|----------|-----------|------|-----------|
| FDATA | 16 | | Data word |

Possible error conditions:

- file pointer out of range
- phrase file selected
- audio file selected

Functional Description

2.2.3.12 Write Data

This commands can be used in binary access mode only. A single word is written at the position of the file pointer. The file pointer is advanced by one word automatically. Note, that for FLASH memory only zeroes can be overwritten by ones. This restriction occurs only if an already used value within an existing file is to be overwritten.

Table 45 Write Data Parameters

| Register | # of Bits | Name | Comment |
|----------|-----------|------|---|
| FCMD | 5 | CMD | Access Mode Command Code (including mode) |
| FDATA | 16 | | Data word |

Possible error conditions:

- file pointer out of range (for existing files only)
- voice prompt memory selected
- memory full
- audio file selected

Functional Description

2.2.4 Low Level Memory Management Commands

These commands allow the direct access of any location (single word) of the external memory. Additionally it is possible to erase any block in case of a flash device. These commands should not be used during normal operation as they may interfere with the file system. No file must be open when one of these commands is given.

The primary use of these commands is the in-system programming of a flash device with voice prompts. Please refer to the appropriate Application Notes.

2.2.4.1 Set Address

This command sets the 24 bit address pointer APTR. Only the address bits A₈-A₂₃ are set, the address bits A₀-A₇ are automatically cleared.

Table 46 Set Address Parameters

| Register | # of Bits | Name | Comment |
|----------|-----------|------|--|
| FCMD | 5 | CMD | Set Address command code |
| FDATA | 16 | ADR | Address bits A ₈ -A ₂₃ of address pointer APTR |

Possible error conditions:

- file open

2.2.4.2 DMA Read

This command reads a single word addressed by APTR. After the read access APTR is automatically incremented by one. Table 47 shows the parameters for this command.

Table 47 DMA Read Parameters

| Register | # of Bits | Name | Comment |
|----------|-----------|------|-----------------------|
| FCMD | 5 | CMD | DMA Read command code |

Table 48 DMA Read Results

| Register | # of Bits | Name | Comment |
|----------|-----------|------|------------------------------|
| FDATA | 16 | DATA | Data read from address APTR. |

Possible error conditions:

- file open

2.2.4.3 DMA Write

This command writes a single word to the location addressed by APTR. After the write access APTR is automatically incremented by one. Table 49 shows the parameters for this command.

Table 49 DMA Write Parameters

| Register | # of Bits | Name | Comment |
|----------|-----------|------|----------------------------|
| FCMD | 5 | CMD | DMA Write command code |
| FDATA | 16 | DATA | Data to be written to APTR |

Possible error conditions:

- file open

Note: If flash memory is connected the actual write is only performed when the last word within a page is written. Until then the data is merely buffered in the flash device. Please check the flash memory data sheets on page size.

2.2.4.4 Block Erase

This command erases the physical block which includes the address given by APTR. The actual amount of memory erased by this command depends on the block size of the flash device. Table 50 shows the parameters for this command.

Table 50 Block Erase Parameters

| Register | # of Bits | Name | Comment |
|----------|-----------|------|--------------------------|
| FCMD | 5 | CMD | Block Erase command code |

Possible error conditions:

- file open
- ARAM/DRAM configured

Functional Description

2.2.5 Execution Time

The execution time of the file commands is determined by four factors:

1. Internal state of the PSB 2168
2. Memory configuration
3. Memory state
4. Individual characteristics of the memory devices

Therefore there is no general formula for an exact calculation of the execution time for file commands. For ARAM/DRAM items three and four are not significant as the memory access timing is always fixed and no additional delay is incurred for erasing memory blocks. However, the amount of memory has significant impact on the initialization in case of ARAM and flash.

For flash devices the particular location of a write access in combination with the internal organization of the memory device may result in a block erase and subsequent write accesses in order to copy data. In this case the individual erase and write timing of the attached devices also prolongs the execution time.

The first factor, the internal state of the PSB 2168, can influence all file commands regardless of the memory type attached. In general the PSB 2168 may delay any file command by up to 30 ms. However, it is possible to skip this delay if the following conditions hold:

1. The command is not *initialize/activate*
2. Neither the DTMF detector nor the speech coder nor the speech decoder are running

If neither condition is violated then the PSB 2168 can be forced to start command execution immediately. This is done by setting the EIE bit in the FCMD register along with the command code.

Table 51 gives an indication of the execution time for two typical memory configurations.

Table 51 Execution Times

| Command | ARAM (4 MBit) | KM29LV040 |
|--------------------------------|--------------------|----------------|
| Initialize | 40 s ¹⁾ | <11 s |
| Activate | < 10 ms | 3 s |
| Open File /Open Next Free File | <10 ms | <26 ms |
| Seek (within 4 MBit File) | <0.5 s | <0.5 s |
| Seek (within phrase file) | <1 ms | <1 ms |
| Cut File | <5 ms | <5 ms |
| Compress File | #units * 30 ms | #units * 30 ms |
| Access File Descriptor | <10 ms | <10 ms |

Functional Description

Table 51 Execution Times

| Command | ARAM (4 MBit) | KM29LV040 |
|--------------------|---------------|-----------|
| Memory Status | <10 ms | <10 ms |
| Read/Write Data | <10 ms | <10 ms |
| Garbage Collection | <20 ms | 3 s |

¹⁾ less than 20 ms for DRAM

2.2.6 Special Notes on File Commands

1. No MMU commands must be inserted between opening a file and writing data to it, either by writing data to a binary file or by enabling the coder for audio files. Therefore reading or writing the file descriptor (e.g. user data word) is only allowed after all data writing has happened.
2. If an audio file has been opened for replay, a Write File Descriptor Command must be followed by a Seek command before the decoder can be enabled.

Functional Description

2.3 Miscellaneous

2.3.1 Real Time Clock

The PSB 2168 supplies a real time clock which maintains time with a resolution of a second and a range of up to a year. There are two registers which contain the current time and date (table 52).

Table 52 Real Time Clock Registers

| Register | # of Bits | Name | Comment |
|----------|-----------|------|-----------------|
| RTC1 | 6 | SEC | Seconds elapsed |
| RTC1 | 6 | MIN | Minutes elapsed |
| RTC2 | 5 | HR | Hours elapsed |
| RTC2 | 11 | DAY | Days elapsed |

The real time clock maintains time during normal mode and power down mode only if the auxiliary oscillator OSC is running and the RTC is enabled.

Note: Writing out-of-range values to RTC1 and RTC2 results in undefined operation of the RTC

2.3.2 SPS Control Register

The two SPS outputs (SPS₀, SPS₁) can be used as either general purpose outputs, extended address outputs for Voice Prompt EPROM or as status register outputs. Table 53 shows the associated register.

Table 53 SPS Registers

| | | | |
|--------|---|------|-------------------------------------|
| SPSCTL | 1 | SP0 | Output Value of SPS ₀ |
| SPSCTL | 1 | SP1 | Output Value of SPS ₁ |
| SPSCTL | 3 | MODE | Mode of Operation |
| SPSCTL | 4 | POS | Position for status register window |

When used as status register outputs, the status register bit at position POS appears at SPS₀ and the bit at position POS+1 appears at SPS₁. This mode of operation can be used for debugging purposes or direct polling of status register bits.

2.3.3 Reset and Power Down Mode

The PSB 2168 can be in either reset mode, power down mode or active mode. During reset the PSB 2168 clears the hardware configuration registers and stops both internal

Functional Description

and external activity. The address lines MA₀-MA₁₅ provide a weak low until they are actually used as address lines (strong outputs) or auxiliary port pins (I/O). In reset mode the hardware configuration registers can be read and written. With the first access to a read/write register the PSB 2168 enters active mode. In this mode the main oscillator is running and normal operation takes place. By setting the power down bit (PD) the PSB 2168 can be brought to power down mode.

Table 54 Power Down Bit

| Register | # of Bits | Name | Comment |
|----------|-----------|------|-----------------|
| CCTL | 1 | PD | power down mode |

In power down mode the main oscillator is stopped and, depending on HWCONFIG2:PPM), the memory control lines are released (weak high). Depending on the configuration (ARAM/DRAM, APP) the PSB 2168 may still generate external activity (e.g. refresh cycles). The PSB 2168 enters active mode again upon an access to a read/write register. Figure 29 shows a state chart of the modes of the PSB 2168.

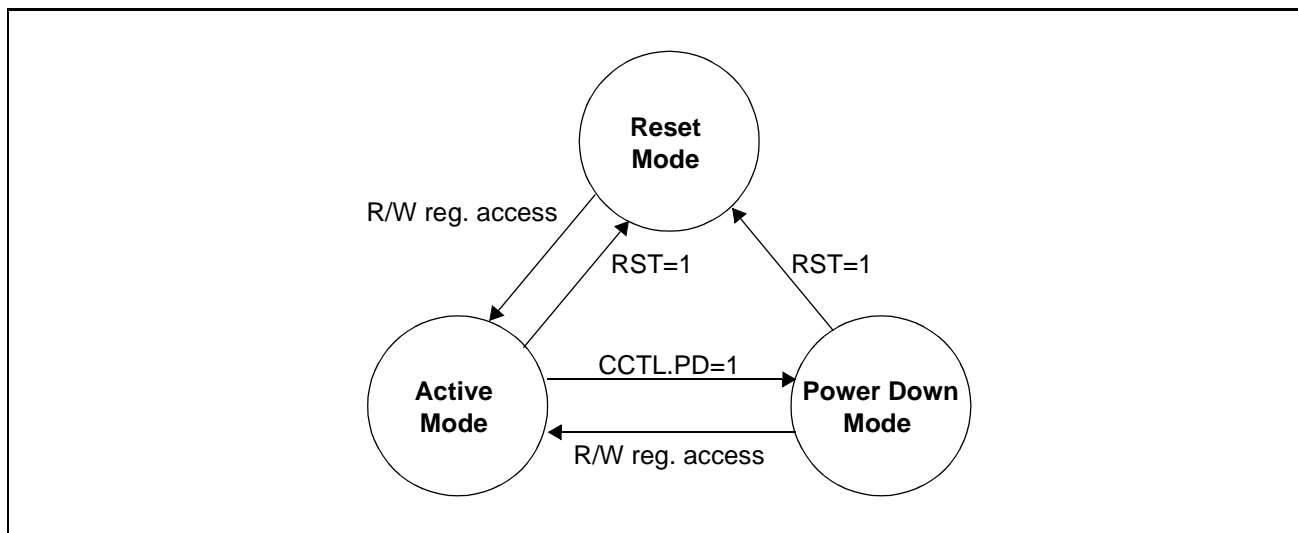

Figure 29 Operation Modes - State Chart

2.3.4 Interrupt

The PSB 2168 can generate an interrupt to inform the host of an update of the STATUS register according to table 55. An interrupt mask register (INTM) can be used to disable or enable the interrupting capability of each bit of the STATUS register except ABT individually.

Functional Description

Table 55 Interrupt Source Summary

| STATUS (old) | STATUS (new) | Set by | Reset by |
|--------------|--------------|------------------------------|--------------------------|
| RDY=0 | RDY=1 | Command completed | Command issued |
| CIA=0 | CIA=1 | New Caller ID byte available | CIDCTL0 read |
| CD=0 | CD=1 | Carrier detected | Carrier lost |
| CD=1 | CD=0 | Carrier lost | Carrier detected |
| CPT=0 | CPT=1 | Call progress tone detected | CPT lost |
| CPT=1 | CPT=0 | Call progress tone lost | CPT detected |
| CNG=0 | CNG=1 | Fax calling tone detected | CNG lost |
| DTV=0 | DTV=1 | DTMF tone detected | DTMF tone lost |
| DTV=1 | DTV=0 | DTMF tone lost | DTMF tone detected |
| ATV=0 | ATV=1 | Alert tone detected | Alert tone lost |
| ATV=1 | ATV=0 | Alert tone lost | Alert tone detected |
| BSY=1 | BSY=0 | File command completed | New command issued |
| SD=0 | SD=1 | Speech activity detected | Speech activity lost |
| SD=1 | SD=0 | Speech activity lost | Speech activity detected |

An interrupt is internally generated if any combination of these events occurs and the interrupt is not masked. The interrupt is cleared when the host reads the STATUS register. If a new event occurs while the host reads the status register, the status register is updated *after* the current access is terminated and a new interrupt is generated immediately after the access has ended.

Note: If the internal interrupt occurs after the controller has already selected the device but not yet read the STATUS word, then the STATUS word is updated and the internal interrupt is cleared. Therefore the controller should always evaluate the STATUS word when read.

2.3.5 Abort

If the PSB 2168 cannot continue the current operations in progress (e.g. due to a transient loss of power) it stops operation and initializes all read/write registers to their reset state. After that it sets the ABT bit of the STATUS register and generates an interrupt. The PSB 2168 discards all commands with the exception of a write command to the revision register while ABT is set. Only after the write command to the revision register (with any value) the ABT bit is reset and a reinitialization can take place.

Functional Description
2.3.6 Revision Register

The PSB 2168 contains a revision register. This register is read only and does not influence operation in any way. A write to the revision register clears the ABT bit of the STATUS register but does not alter the content of the revision register.

2.3.7 Hardware Configuration

The PSB 2168 can be adapted to various external hardware configurations by four special registers: HWCONFIG0 to HWCONFIG3. These registers are usually only written once during initialization and must not be changed while the PSB 2168 is in active mode. It is mandatory that the programmed configuration reflects the external hardware for proper operation. Special care must be taken to avoid I/O conflicts or excess current by enabling inputs without an external driving source. Table 56 can be used as a checklist.

Table 56 Hardware Configuration Checklist

| Register | Name | Value | Check |
|-----------|---------------------------|-------|---------------------------------------|
| HWCONFIG0 | $\overline{\text{PFRDY}}$ | 1 | FRDY must not float |
| HWCONFIG0 | OSC | 1 | OSC1/2 must be connected to a crystal |

Functional Description

2.3.8 Auxiliary Clock Generation

The PSB 2168 can generate a data clock (at AFECLK) and a frame synchronization signal (at AFEFS) for typical single channel codecs. The PSB 2168 provides two pairs of frequencies according to table 57.

Table 57 Auxiliary Clock Generation

| CM1 | CM0 | AFECLK | AFEFS | Comment |
|-----|-----|-----------|-----------|-------------------------------------|
| 0 | 0 | L | L | auxiliary clock generation disabled |
| 0 | 1 | undefined | undefined | reserved |
| 1 | 0 | 512 kHz | 8 kHz | e.g. MC145480 |
| 1 | 1 | 1.536 MHz | 8 kHz | e.g. TP3054 |

Note: These frequencies are derived from the main oscillator. Therefore the values listed in the table are only valid for the specified oscillator frequencies (see HWCONFIG1)

2.3.9 Dependencies of Modules

There are some restrictions concerning the modules that can be enabled at the same time (table 58). A checked cell indicates that the two modules (defined by the row and the column of the cell) must not be enabled at the same time.

Table 58 Dependencies of Modules

| | Speech Encoder | Speech Decoder | Line EC (24 ms) | DTMF Detector | File Command |
|-----------------|----------------|-----------------|-----------------|---------------|--------------|
| Speech Encoder | | X | X | | B,O,I |
| Speech Decoder | X | | X ¹⁾ | | B,O,I |
| Line EC (24 ms) | X | X ¹⁾ | | | B,O |
| DTMF Detector | | | | | B,I |
| File Command | B,O,I | B,O,I | B,O | B,I | |

¹⁾ if Speech Decoder is running at slow speed

There are three classes of file commands denoted by the letters B, O and I. Table 59 shows the definition of these classes:

Functional Description

Table 59 File Command Classes

| Class | Description |
|--------------|--|
| B | Background commands (Activate, Recompress, Garbage Collection, Initialize) |
| O | Open Commands (Open, Open Next Free File) |
| I | Any command executed with EIE=1 (i.e. immediate execution) |

Examples:

- The line echo canceller (in 24 ms mode) cannot be enabled when the speech decoder is running at slow speed.
- If the DTMF detector is running, none of the background file commands (B) must be executed. In addition, no file command must be executed with immediate execution enabled (I). However, files may be opened and other commands (like read or write) may be executed without immediate execution enabled.

Functional Description

2.4 Interfaces

This section describes the interfaces of the PSB 2168. The PSB 2168 supports both an IOM[®]-2 interface with single and double clock mode and a strobed serial data interface (SSDI). However, these two interfaces cannot be used simultaneously as they share some pins. Both interfaces are for data transfer only and cannot be used for programming the PSB 2168. Table 60 lists the features of the two alternative interfaces.

Table 60 SSDI vs. IOM[®]-2 Interface

| | IOM [®] -2 | SSDI |
|------------------------------|-------------------------------|---------------------------|
| Signals | 4 | 6 |
| Channels (bidirectional) | 2 | 1 |
| Code | linear PCM, A-law, μ -law | linear PCM |
| Synchronization within frame | by timeslot (programmable) | by signal (DXST, DRST) |

2.4.1 IOM[®]-2 Interface

The data stream is partitioned into packets called frames. Each frame is divided into a fixed number of timeslots. Each timeslot is used to transfer 8 bits. Figure 30 shows a commonly used terminal mode (three channels ch_0 , ch_1 and ch_2 with four timeslots each). The first timeslot (in figure 30: B1) is denoted by number 0, the second one (B2) by 1 and so on.

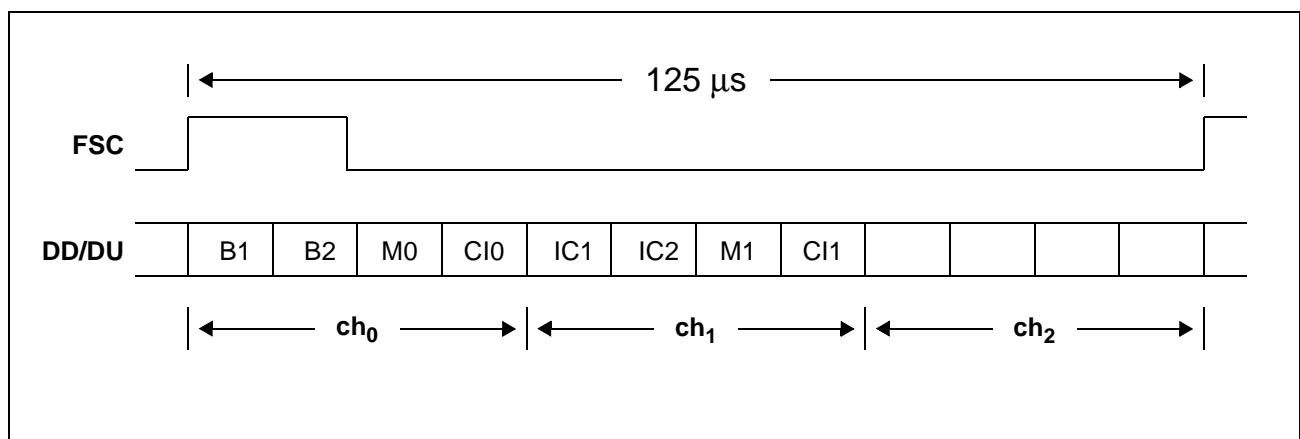

Figure 30 IOM[®]-2 Interface - Frame Structure

The signal FSC is used to indicate the start of a frame. Figure 31 shows as an example two valid FSC-signals (FSC, FSC^{*}) which both indicate the same clock cycle as the first clock cycle of a new frame (T_1).

Note: Any timeslot (including M0, CI0, ...) can be used for data transfer. However, programming is not supported via the monitor channels.

Functional Description

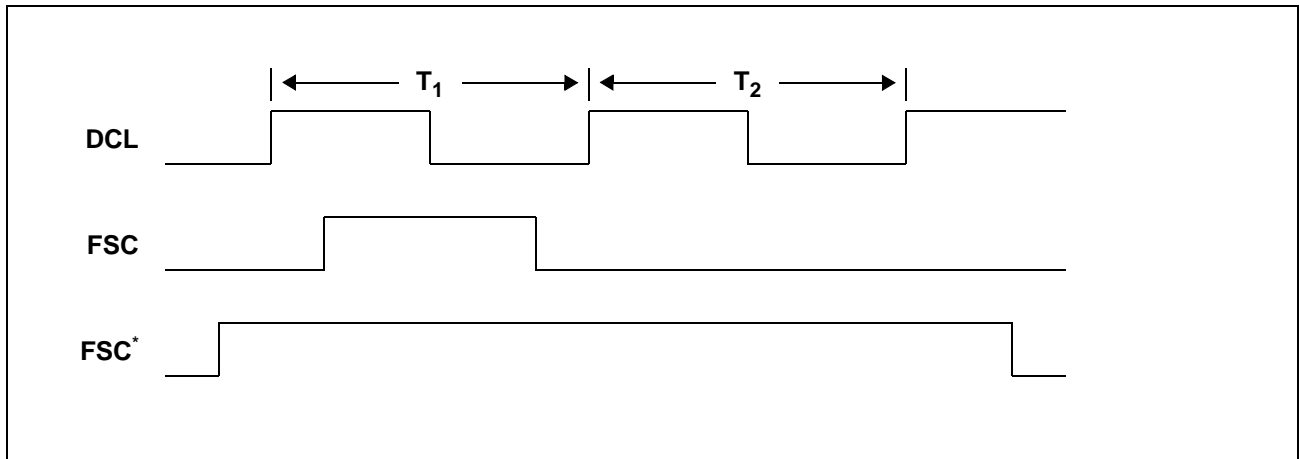

Figure 31 IOM[®]-2 Interface - Frame Start

The PSB 2168 supports both single clock mode and double clock mode. In single clock mode, the bit rate is equal to the clock rate. Bits are shifted out with the rising edge of DCL and sampled at the falling edge. In double clock mode, the clock runs at twice the bit rate. Therefore for each bit there are two clock cycles. Bits are shifted out with the rising edge of the first clock cycle and sampled with the falling edge of the second clock cycle. Figure 32 shows the timing for single clock mode and figure 33 shows the timing for double clock mode.

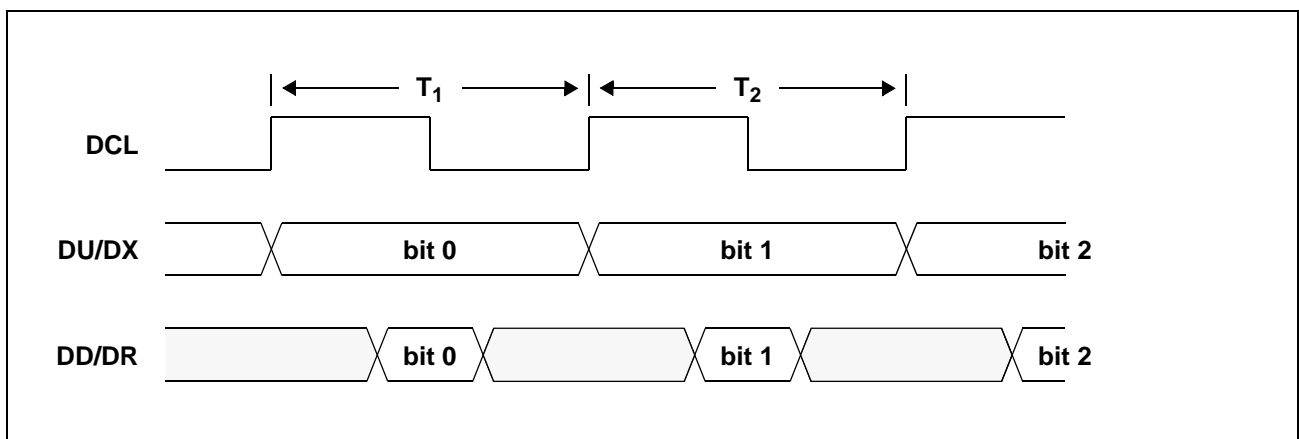

Figure 32 IOM[®]-2 Interface - Single Clock Mode

Functional Description

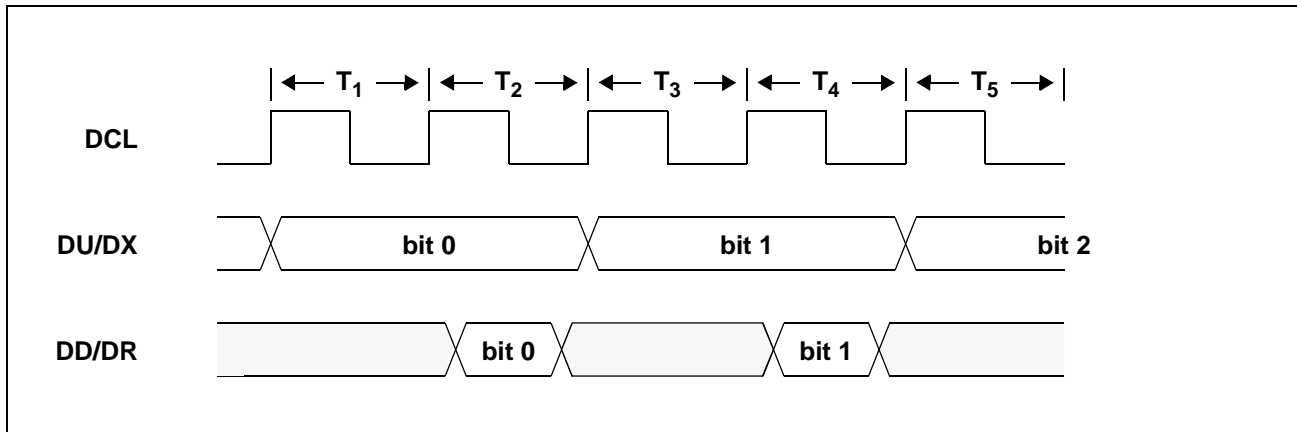

Figure 33 IOM[®]-2 Interface - Double Clock Mode

The PSB 2168 supports up to two channels simultaneously for data transfer. Both the coding (PCM or linear) and the data direction (DD/DU assignment for transmit/receive) can be programmed individually for each channel. Table 61 shows the registers used for configuration of the IOM[®]-2 interface.

Table 61 IOM[®]-2 Interface Registers

| Register | # of Bits | Name | Comment |
|----------|-----------|------|---|
| SDCONF | 1 | EN | Interface enable |
| SDCONF | 1 | DCL | Selection of clock mode |
| SDCONF | 6 | NTS | Number of timeslots within frame |
| SDCHN1 | 1 | EN | Channel 1 enable |
| SDCHN1 | 6 | TS | First timeslot (channel 1) |
| SDCHN1 | 1 | DD | Data Direction (channel 1) |
| SDCHN1 | 1 | PCM | 8 bit code or 16 bit linear PCM (channel 1) |
| SDCHN1 | 1 | PCD | 8 bit code (A-law or μ -law, channel 1) |
| SDCHN2 | 1 | EN | Channel 2 enable |
| SDCHN2 | 6 | TS | First timeslot (channel 2) |
| SDCHN2 | 1 | DD | Data Direction (channel 2) |
| SDCHN2 | 1 | PCM | 8 bit code or 16 bit linear PCM (channel 2) |
| SDCHN2 | 1 | PCD | 8 bit code (A-law or μ -law, channel 2) |

In A-law or μ -law mode, only 8 bits are transferred and therefore only one timeslot is needed for a channel. In linear mode, 16 bits are needed for a single channel. In this mode, two consecutive timeslots are used for data transfer. Bits 8 to 15 are transferred

Functional Description

within the first timeslot and bits 0 to 7 are transferred within the next timeslot. The first timeslot must have an even number. The most significant bit is always transmitted first.

2.4.2 SSDI Interface

The SSDI interface is intended for seamless connection to low-cost burst mode controllers (e.g. PMB 27251) and supports a single channel in each direction. The data stream is partitioned into frames. Within each frame one 16 bit value can be sent and received by the PSB 2168. The start of a frame is indicated by the rising edge of FSC. Data is always sampled at the falling edge of DCL and shifted out with the rising edge of DCL.

The SSDI transmitter and receiver are operating independently of each other except that both use the same FSC and DCL signal.

2.4.2.1 SSDI Interface - Transmitter

The PSB 2168 indicates outgoing data (on signal DX) by activating DXST for 16 clocks. The signal DXST is activated with the same rising edge of DCL that is used to send the first bit (Bit 15) of the data. DXST is deactivated with the first rising edge of DCL after the last bit has been transferred. The PSB 2168 drives the signal DX only when DXST is activated. Figure 34 shows the timing for the transmitter.

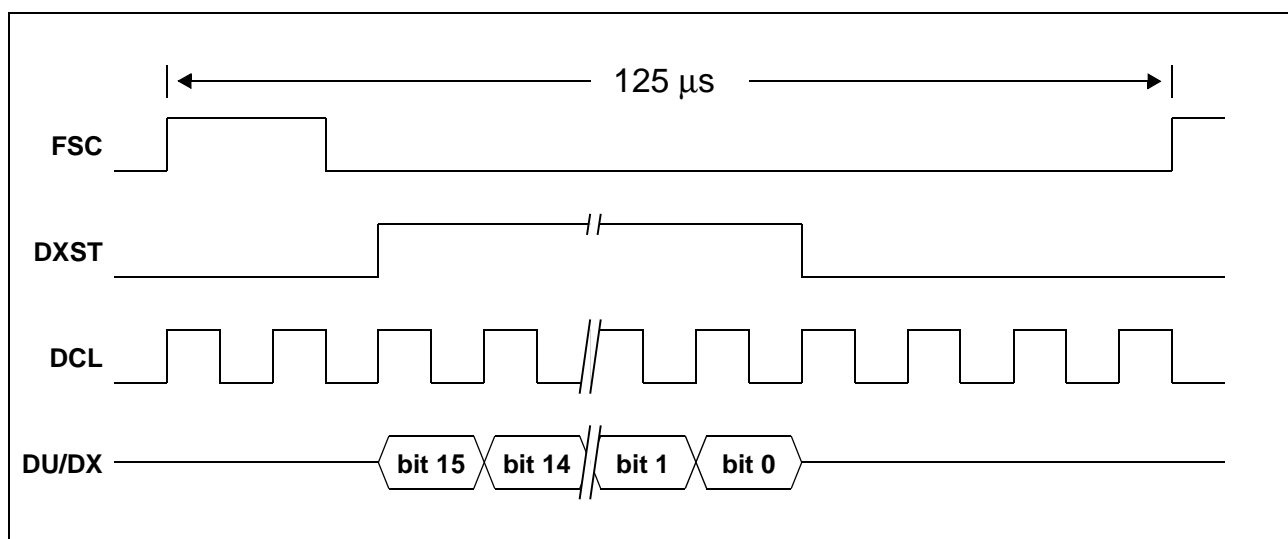

Figure 34 SSDI Interface - Transmitter Timing

2.4.2.2 SSDI Interface - Receiver

Valid data is indicated by an active DRST pulse. Each DRST pulse must last for exactly 16 DCL clocks. As there may be more than one DRST pulses within a single frame the PSB 2168 can be programmed to listen to the n-th pulse with n ranging from 1 to 16. In order to detect the first pulse properly, DRST must not be active at the rising edge of FSC. In figure 35 the PSB 2168 is listening to the third DRST pulse (n=3).

Functional Description

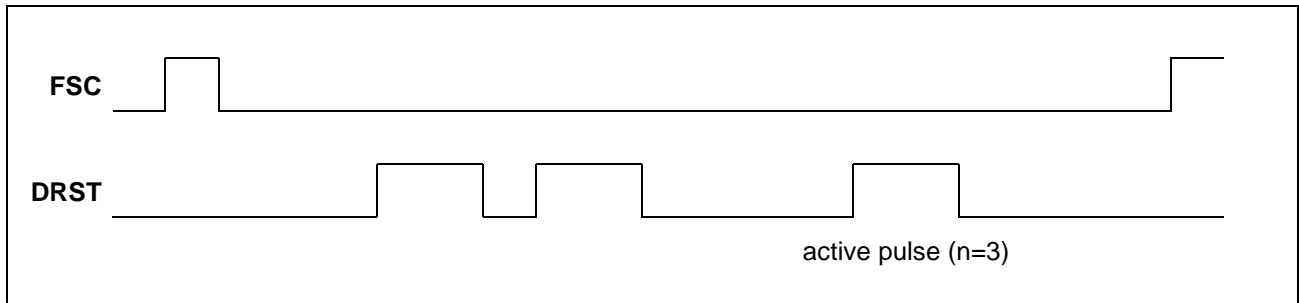

Figure 35 SSDI Interface - Active Pulse Selection

Figure 36 shows the timing for the SSDI receiver.

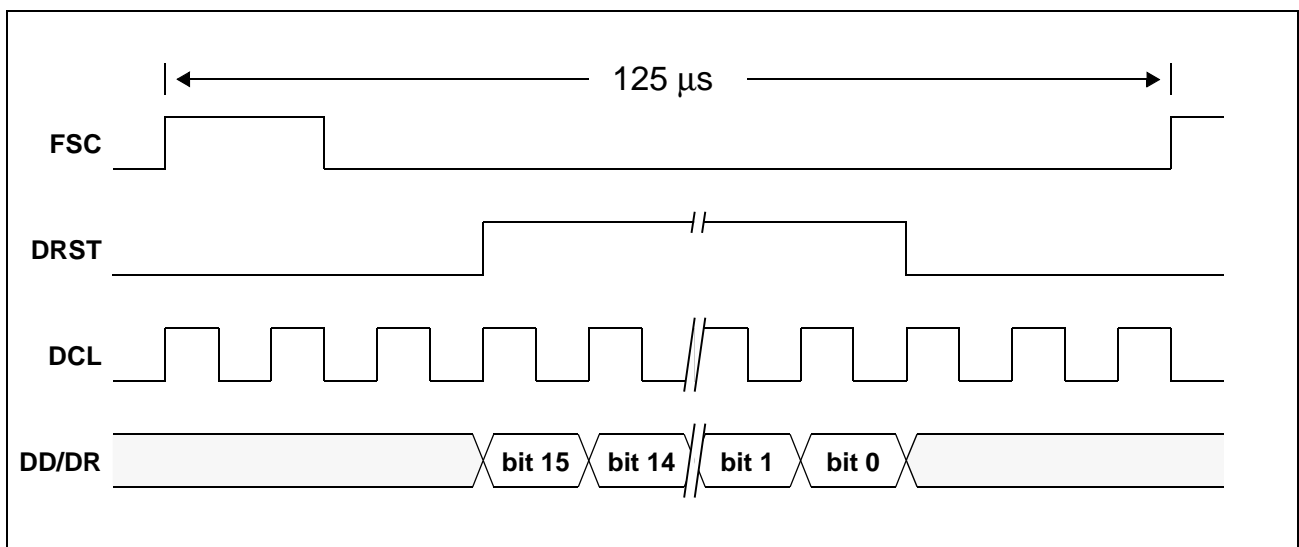

Figure 36 SSDI Interface - Receiver Timing

Table 62 shows the registers used for configuration of the SSDI interface.

Table 62 SSDI Interface Register

| Register | # of Bits | Name | Comment |
|----------|-----------|------|------------------------------|
| SDCHN1 | 4 | NAS | Number of active DRST strobe |

2.4.3 Serial Control Interface

The serial control interface (SCI) uses four lines: SDR, SDX, SCLK and \overline{CS} . Data is transferred by the lines SDR and SDX at the rate given by SCLK. The falling edge of \overline{CS} indicates the beginning of an access. Data is sampled by the PSB 2168 at the rising edge of SCLK and shifted out at the falling edge of SCLK. Each access must be terminated by a rising edge of \overline{CS} . The accesses to the PSB 2168 can be divided into three classes:

1. Configuration Read/Write
2. Status/Data Read
3. Register Read/Write

If the PSB 2168 is in power down mode, a read access to the status register does not deliver valid data with the exception of the RDY bit. After the status has been read the access can be either terminated or extended to read data from the PSB 2168. A register read/write access can only be performed when the PSB 2168 is ready. The RDY bit in the status register provides this information.

Any access to the PSB 2168 starts with the transfer of 16 bits to the PSB 2168 over line SDR. This first word specifies the access class, access type (read or write) and, if necessary, the register accessed. If a configuration register is written, the first word also includes the data and the access is terminated. Likewise, if a register read is issued, the access is terminated after the first word. All other accesses continue by the transfer of the status register from the PSB 2168 over line SDX. If a register (excluding configuration) is to be written, the next 16 bits containing the data are transferred over line SDR and the access is terminated. Figures 37 to 40 show the timing diagrams for the different access classes and types to the PSB 2168.

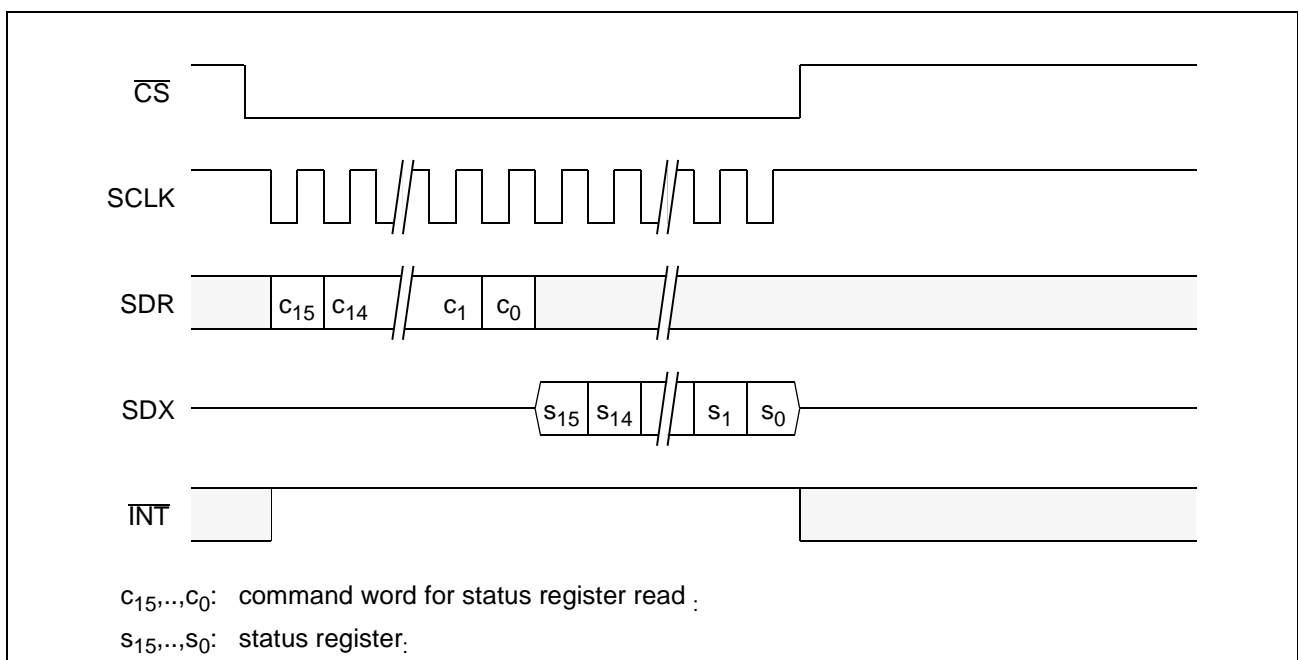

Figure 37 Status Register Read Access

Functional Description

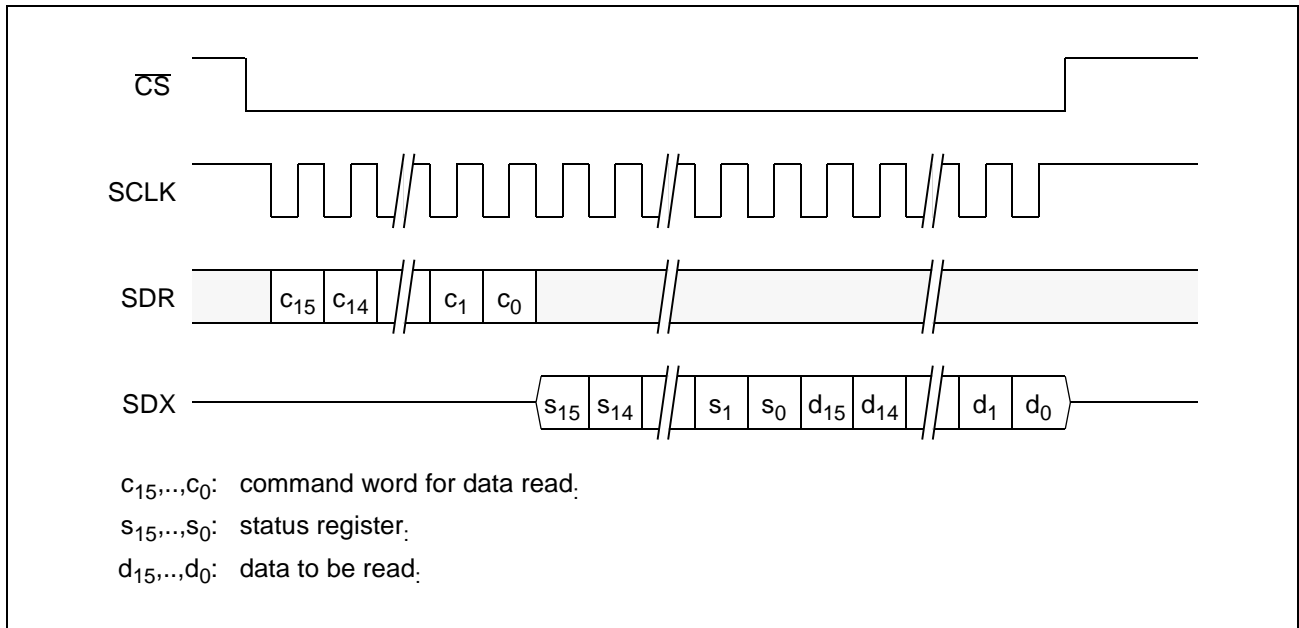

Figure 38 Data Read Access

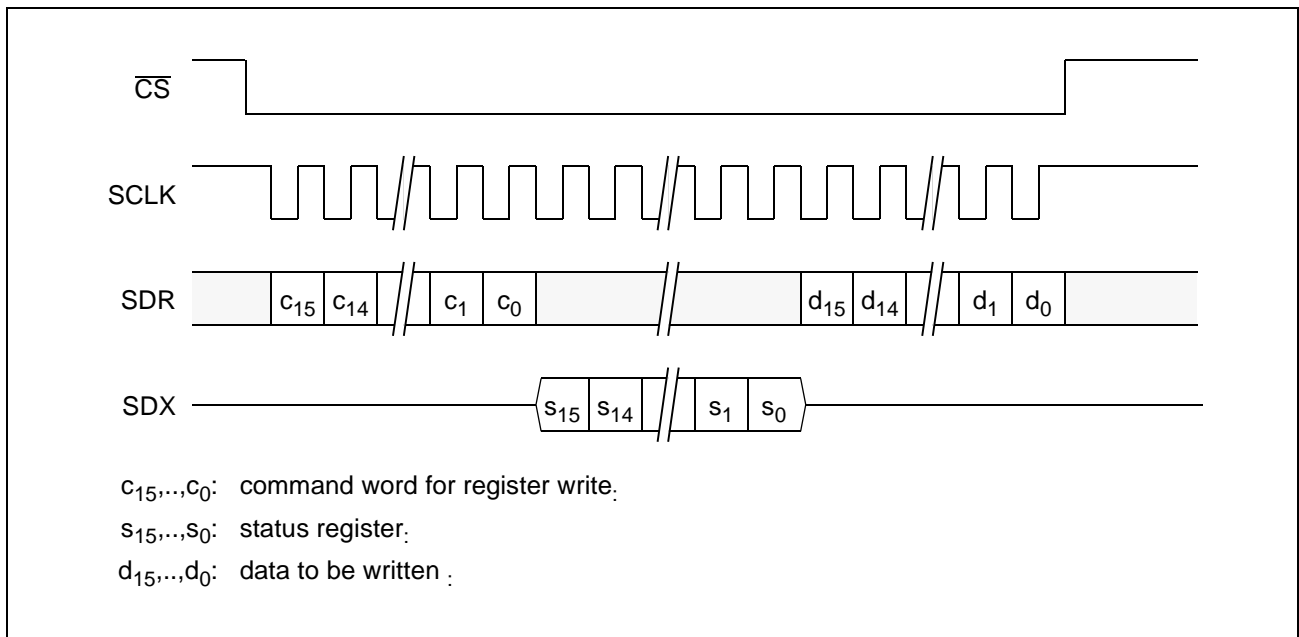

Figure 39 Register Write Access

Functional Description

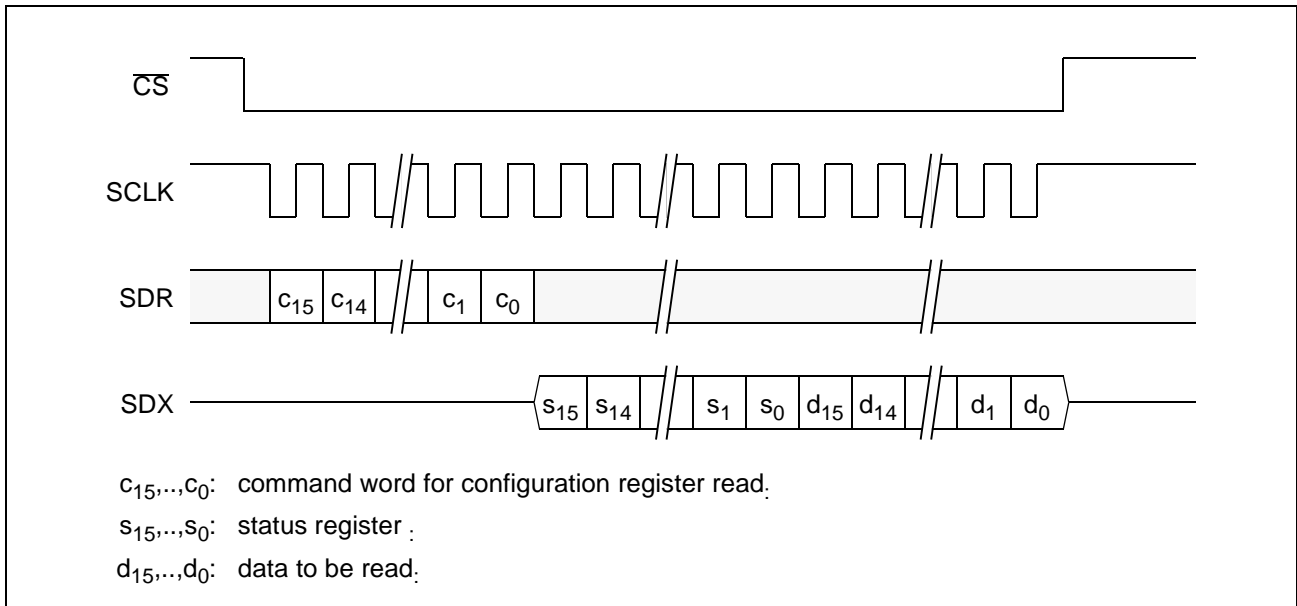

Figure 40 Configuration Register Read Access

Configuration registers at even addresses use bit positions d_7-d_0 while configuration registers at odd addresses use bit positions $d_{15}-d_8$.

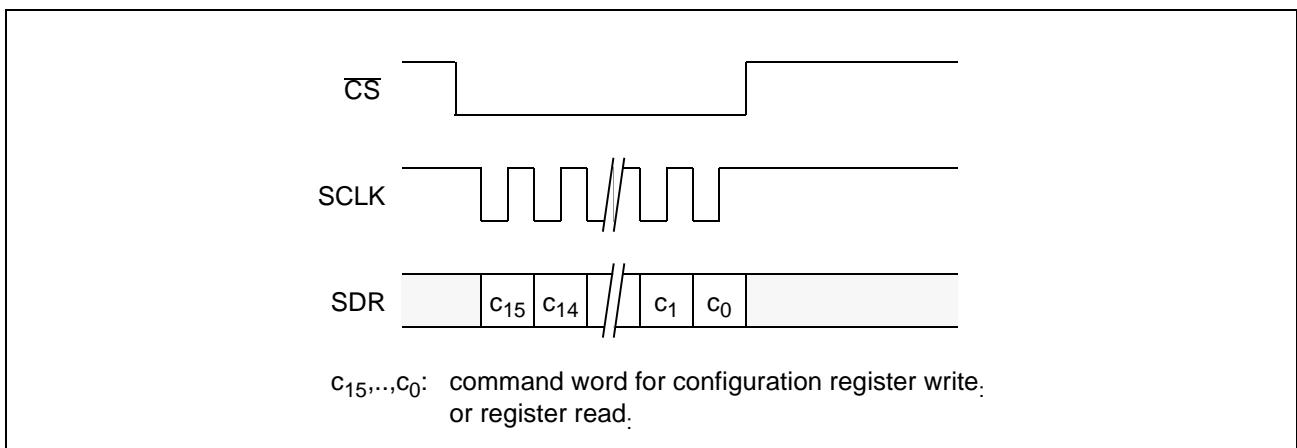

Figure 41 Configuration Register Write Access or Register Read Command

The internal interrupt signal is cleared when the first bit of the status register is put on SDX. However, externally the signal \overline{INT} is deactivated as long as \overline{CS} stays low. If the internal interrupt signal is not cleared or another event causing an interrupt occurs while the microcontroller is already reading the status belonging to the first event then INT goes low again immediately after \overline{CS} is removed. The timing is shown in figure 37. Table 63 shows the formats of the different command words. All other command words are reserved.

Functional Description

Table 63 Command Words for Register Access

| | | | | | | | | | | | | | | | | |
|--|----|----|----|----|-----|----|---|------|---|---|---|---|---|---|---|---|
| | 15 | 14 | 13 | 12 | 11 | 10 | 9 | 8 | 7 | 6 | 5 | 4 | 3 | 2 | 1 | 0 |
| Read Status Register or Data Read Access | 0 | 0 | 1 | 1 | 0 | 0 | 0 | 0 | 0 | 0 | 0 | 0 | 0 | 0 | 0 | 0 |
| Read Register | 0 | 1 | 0 | 1 | REG | | | | | | | | | | | |
| Write Register | 0 | 1 | 0 | 0 | REG | | | | | | | | | | | |
| Read Configuration Reg. | 0 | 1 | 1 | 1 | 0 | 0 | R | 0 | 0 | 0 | 0 | 0 | 0 | 0 | 0 | 0 |
| Write Configuration Reg. | 0 | 1 | 1 | 0 | 0 | 0 | W | DATA | | | | | | | | |

In case of a configuration register write, W determines which configuration register is to be written (table 64):

Table 64 Address Field W for Configuration Register Write

| | | |
|---|---|------------|
| 9 | 8 | Register |
| 0 | 0 | HWCONFIG 0 |
| 0 | 1 | HWCONFIG 1 |
| 1 | 0 | HWCONFIG 2 |
| 1 | 1 | HWCONFIG 3 |

In case of a configuration register read, R determines which pair of configuration registers is to be read (table 65):

Table 65 Address Field R for Configuration Register Read

| | |
|---|-------------------------|
| 9 | Register pair |
| 0 | HWCONFIG 0 / HWCONFIG 1 |
| 1 | HWCONFIG 2 / HWCONFIG 3 |

Note: Reading any register except the status register or a hardware configuration register requires at least two accesses. The first access is a register read command (figure 41). With this access the register address is transferred to the. After that access data read accesses (figure 38) must be executed. The first data read access with STATUS:RDY=1 delivers the value of the register.

Functional Description

2.4.4 Memory Interface

The PSB 2168 supports either Flash Memory or ARAM/DRAM as external memory for storing messages. If ARAM/DRAM is used, an EPROM can be added optionally to support read-only messages (e.g. voice prompts). Table 66 summarizes the different configurations supported.

Table 66 Supported Memory Configurations

| Mbit | Type | Bank 0 (D ₀ -D ₃) | Bank 1 (D ₄ -D ₇) | Comment |
|--------|-----------|--|--|------------------|
| 1 | ARAM/DRAM | 256kx4 | - | |
| 2 | ARAM/DRAM | 256kx4 | 256kx4 | |
| 4 | ARAM/DRAM | 1Mx4 | - | |
| 4 | ARAM/DRAM | 512kx8 | | |
| 8 | ARAM/DRAM | 1Mx4 | 1Mx4 | |
| 16 | ARAM/DRAM | 4Mx4 | - | 2k or 4k refresh |
| 16 | ARAM/DRAM | 2Mx8 | | 2k refresh |
| 32 | ARAM/DRAM | 4Mx4 | 4Mx4 | 2k or 4k refresh |
| 32 | ARAM/DRAM | 2x2Mx8 | | 2k refresh |
| 64 | ARAM/DRAM | 16Mx4 | - | 4k or 8k refresh |
| 64 | ARAM/DRAM | 8Mx8 | | 4k or 8k refresh |
| 128 | ARAM/DRAM | 16Mx4 | 16Mx4 | 4k or 8k refresh |
| 4-128 | FLASH | 512kx8 devices | | KM29N040 |
| 16-128 | FLASH | 2Mx8 devices | | KM29N16000 |

If ARAM/DRAM is used, the total amount of memory must be a power of two and all devices must be of the same type. The pin FRDY must be tied high.

For flash devices, the PSB 2168 supports in-circuit programming of voice prompts by releasing the control lines during reset and (optionally) power down. Instead of actively driving the lines \overline{FCS} , \overline{FOE} , \overline{FWE} , \overline{FCLE} and \overline{ALE} these lines are pulled high by a weak pullup during reset and (optionally) power down.

Functional Description

2.4.4.1 ARAM/DRAM Interface

The PSB 2168 supports up to two banks of memory which may be 4 bit or 8 bit wide (Figure 42). If both banks are used they must be populated identically.

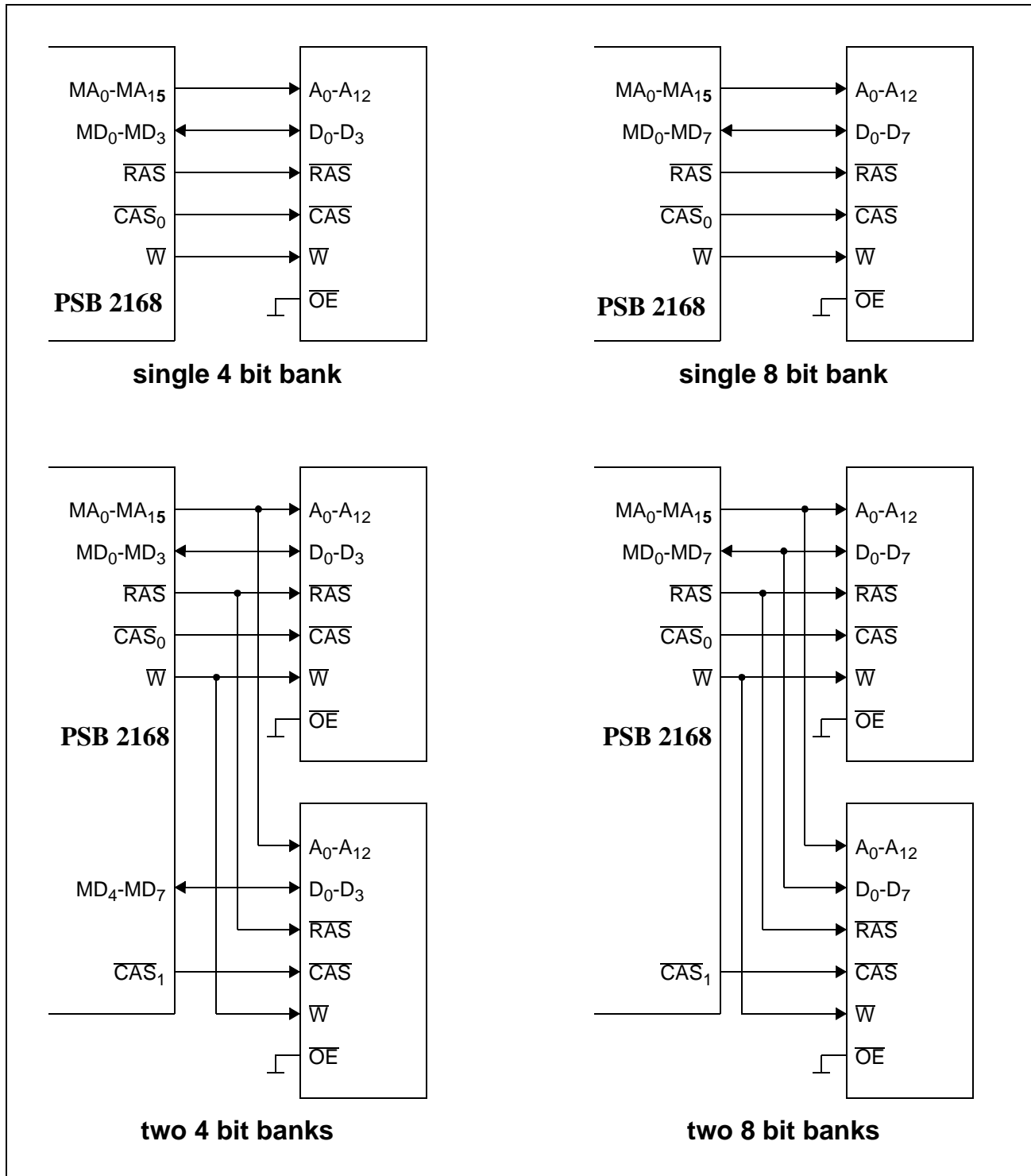

Figure 42 ARAM/DRAM Interface - Connection Diagram

Functional Description

The PSB 2168 also supports different internal organizations of ARAM/DRAM chips. Table 67 shows the necessary connections on the address bus.

Table 67 Address Line Usage (ARAM/DRAM Mode)

| ARAM/DRAM | CS9 ¹⁾ | MA ₀ -MA ₈ | MA ₉ | MA ₁₀ | MA ₁₁ | MA ₁₂ | MA ₁₃ |
|---------------------|-------------------|----------------------------------|-----------------|------------------|------------------|------------------|------------------|
| 256k x4 | 1 | A ₀ -A ₈ | | | | | |
| 512k x8 | 1 | A ₀ -A ₈ | A ₉ | | | | |
| 1M x4 | 0 | A ₀ -A ₈ | A ₉ | | | | |
| 4M x4 (2k refresh) | 0 | A ₀ -A ₈ | A ₉ | A ₁₀ | | | |
| 4M x4 (4k refresh) | 0 | A ₀ -A ₈ | A ₉ | A ₁₀ | A ₁₁ | | |
| 2M x8 | 0 | A ₀ -A ₈ | A ₉ | A ₁₀ | | | |
| 16M x4 (4k refresh) | 0 | A ₀ -A ₈ | A ₉ | A ₁₀ | | A ₁₁ | |
| 16M x4 (8k refresh) | 0 | A ₀ -A ₈ | A ₉ | A ₁₀ | | A ₁₁ | A ₁₂ |
| 8M x8 (4k refresh) | 0 | A ₀ -A ₈ | A ₉ | A ₁₀ | | A ₁₁ | |
| 8M x8 (8k refresh) | 0 | A ₀ -A ₈ | A ₉ | A ₁₀ | | A ₁₁ | A ₁₂ |

¹⁾ see chip control register CCTL

The timing of the ARAM/DRAM interface is shown in figures 43 to 45. The timing is derived from the internal memory clock MCLK* which runs at a quarter of the system clock.

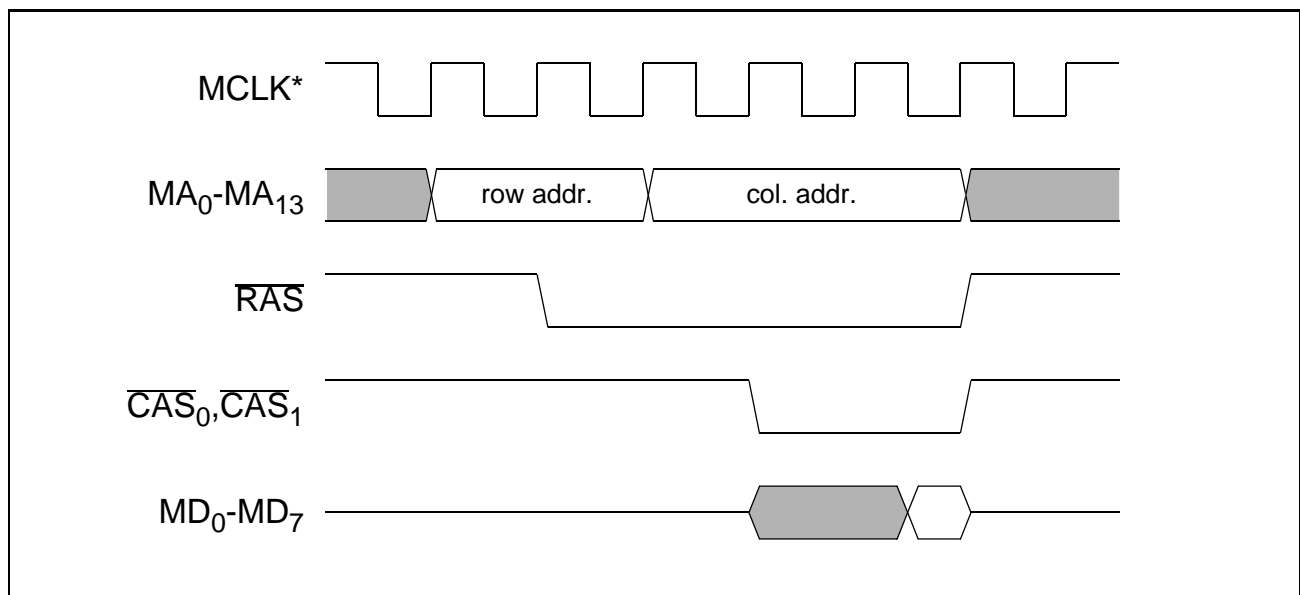

Figure 43 ARAM/DRAM Interface - Read Cycle Timing

Functional Description

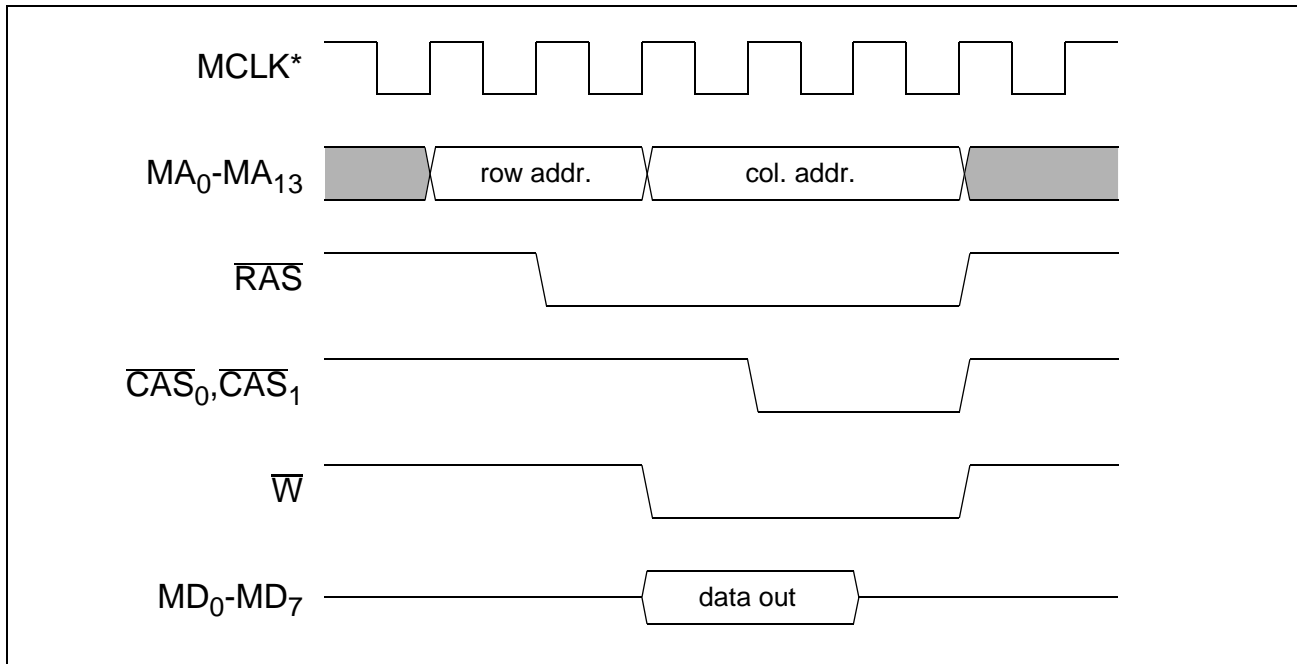

Figure 44 ARAM/DRAM Interface - Write Cycle Timing

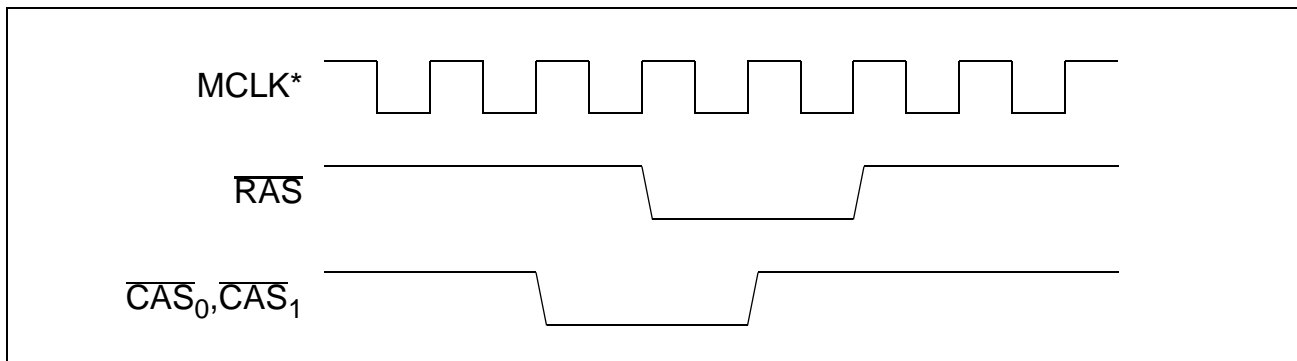

Figure 45 ARAM/DRAM Interface - Refresh Cycle Timing

The PSB 2168 ensures that \overline{RAS} remains inactive for at least one MCLK*-cycle between successive accesses.

The frequency at which refresh cycles are performed is shown in table 68.

Table 68 Refresh Frequency Selection

| Refresh frequency | Comment |
|-----------------------------------|--|
| 64 kHz | Memory access (e.g. recording) in progress |
| 8, 16, 32 or 64 kHz ¹⁾ | No memory access in progress or power-down |

¹⁾ as programmed by HWCONFIG2:RSEL

Functional Description

2.4.4.2 EPROM Interface

The PSB 2168 supports an EPROM in parallel with ARAM/DRAM. This interface is always 8 Bits wide and supports a maximum of 256 kB. Figure 46 shows a connection diagram and figure 47 the timing. This interface supports read cycles only.

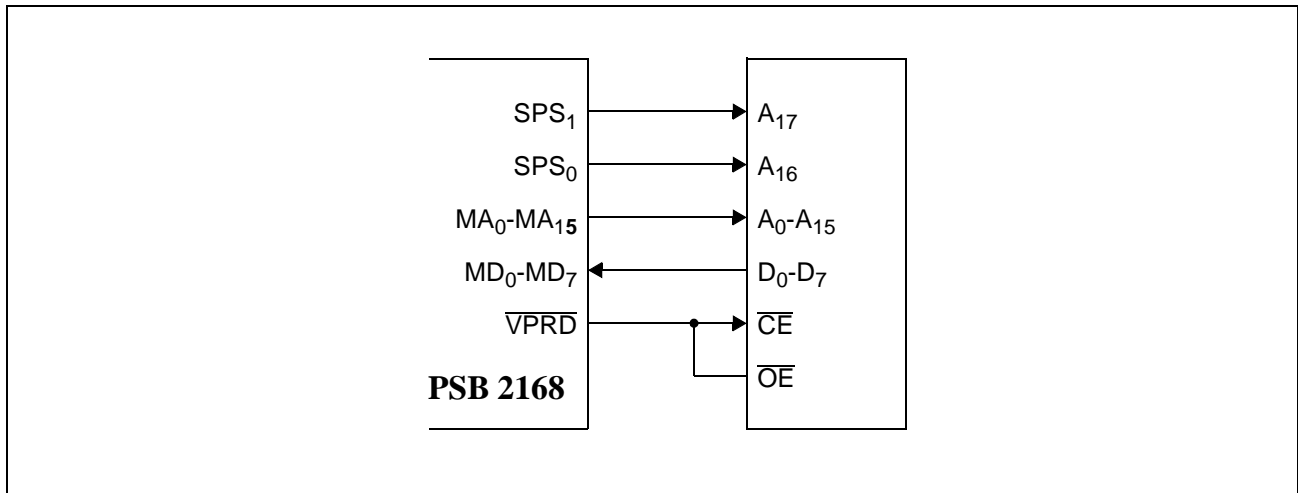

Figure 46 EPROM Interface - Connection Diagram

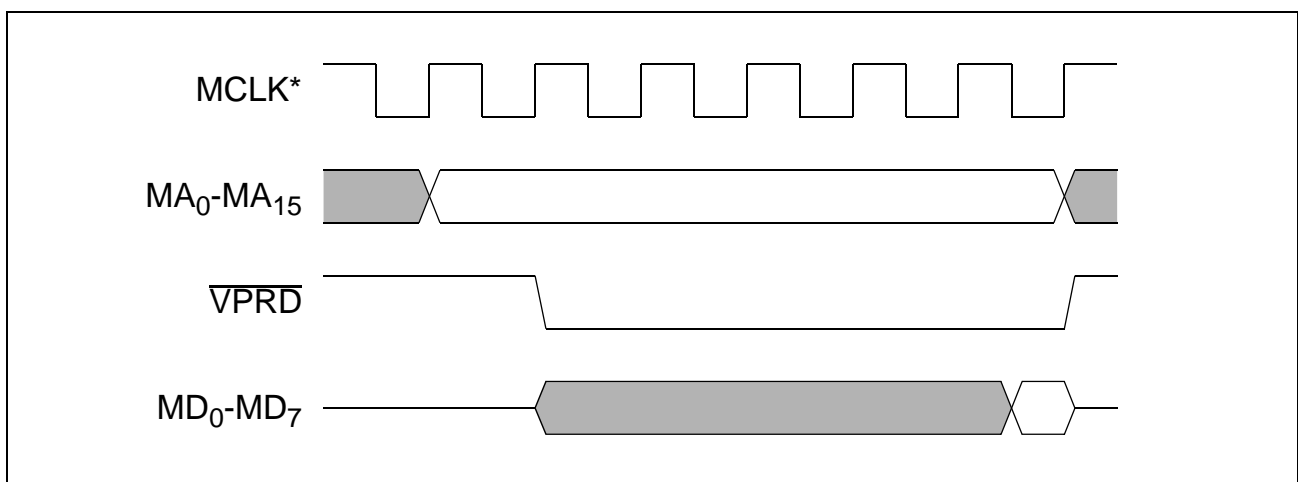

Figure 47 EPROM Interface - Read Cycle Timing

Note: In order to access more than 64 kB the pins SPS₀ and SPS₁ can be programmed to provide the address lines A₁₆ and A₁₇. In this mode A₁₆ and A₁₇ remain stable during the whole read cycle. See the register SPSCTL for programming information.

Functional Description

2.4.4.3 Flash Memory Interface

The PSB 2168 has special support for the KM29N040 and KM29N16000 or equivalent devices. No external components are required for up to four KM29N040. Figure 48 shows the connection diagram for a single device.

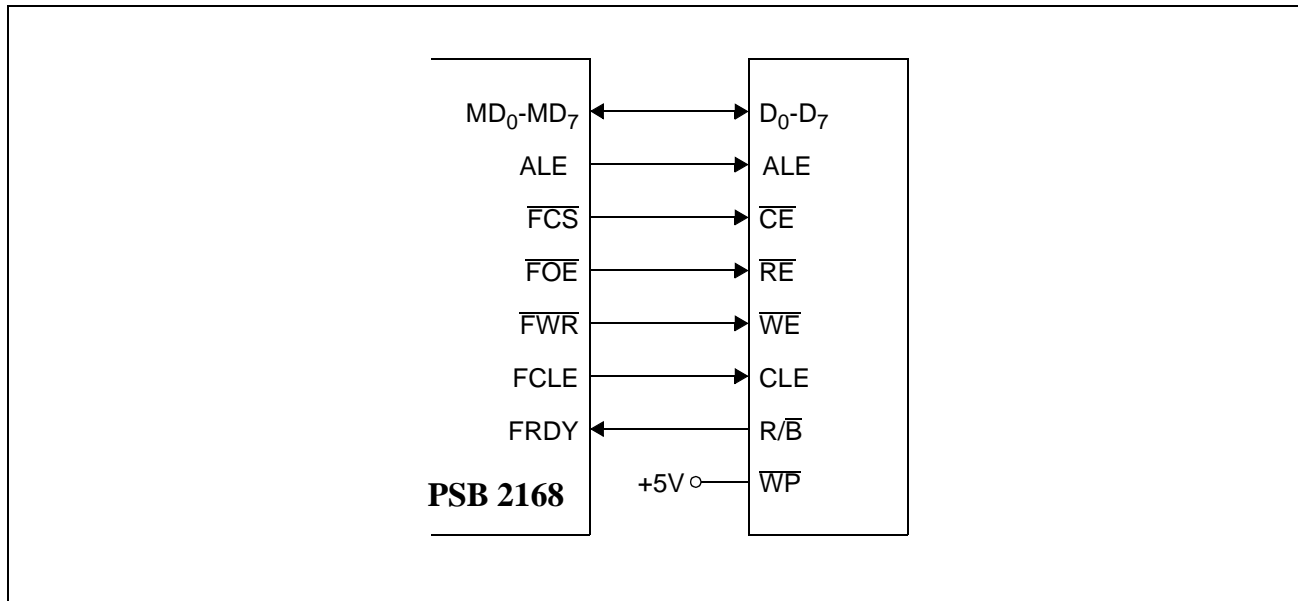

Figure 48 Flash Memory Interface - Connection Diagram

Table 69 shows the signals output during a device access on the MA-lines. The address bits can be used by an external decoder. Up to four KM29N040 are supported directly by the decoded select signals \overline{FCS}_0 - \overline{FCS}_3 .

Table 69 Address Line Usage (Samsung Mode)

| | | | | | | | | | | | |
|--------------------|--------------------|--------------------|--------------------|-----------------|-----------------|-----------------|-----------------|-----------------|-----------------|-----------------|-----------------|
| MA ₁₁ | MA ₁₀ | MA ₉ | MA ₈ | MA ₇ | MA ₆ | MA ₅ | MA ₄ | MA ₃ | MA ₂ | MA ₁ | MA ₀ |
| \overline{FCS}_3 | \overline{FCS}_2 | \overline{FCS}_1 | \overline{FCS}_0 | A ₂₃ | A ₂₂ | A ₂₁ | A ₂₀ | A ₁₉ | A ₁₈ | A ₁₇ | A ₁₆ |

Functional Description

Figure 49 shows an application with three KM29N040 devices.

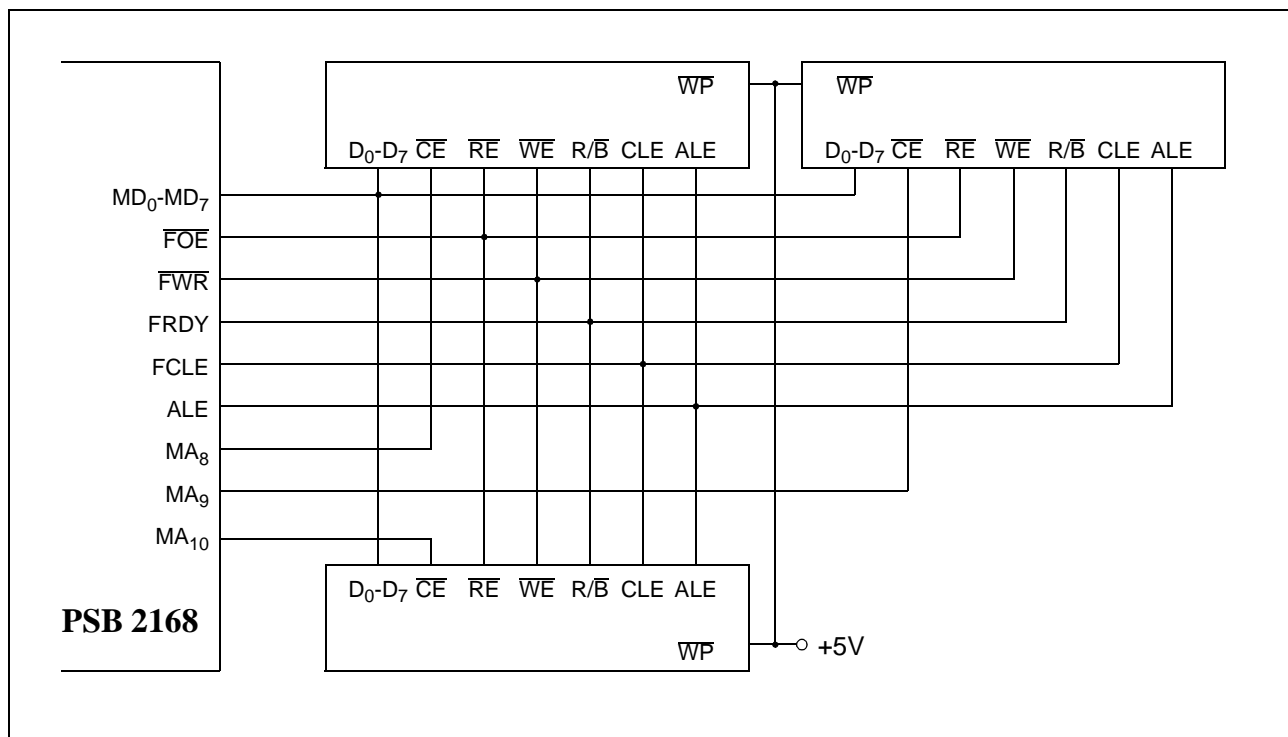

Figure 49 Flash Memory Interface - Multiple Devices

An access to the Flash Memory can consist of several partial access cycles where only the timing of the partial access cycles is defined but not the time between two adjacent partial access cycles. The PSB 2168 performs three types of partial access cycles:

1. Command write
2. Address write
3. Data read/write

Table 70 shows the supported accesses and the corresponding partial access cycles.

Table 70 Flash Memory Command Summary

| Access | Command write | Address write 1 | Address write 2 | Address write 3 | # of Data read/write | Command write |
|-------------|---------------|---------------------------------|----------------------------------|----------------------------------|----------------------|---------------|
| RESET | FF | - | - | - | - | - |
| STATUS READ | 70 | - | - | - | 1 | - |
| BLOCK ERASE | 60 | A ₈ -A ₁₅ | A ₁₆ -A ₂₃ | - | - | D0 |
| READ | 00 | A ₀ -A ₇ | A ₈ -A ₁₅ | A ₁₆ -A ₂₃ | 1-32 | - |
| WRITE | 80 | A ₀ -A ₇ | A ₈ -A ₁₅ | A ₁₆ -A ₂₃ | 1-32 | 10 |

Functional Description

The timing for the partial access cycles is shown in figures 50 to 51. Note that both \overline{FCS} and MA_0-MA_{15} remain stable between the first and the last partial access of a device access.

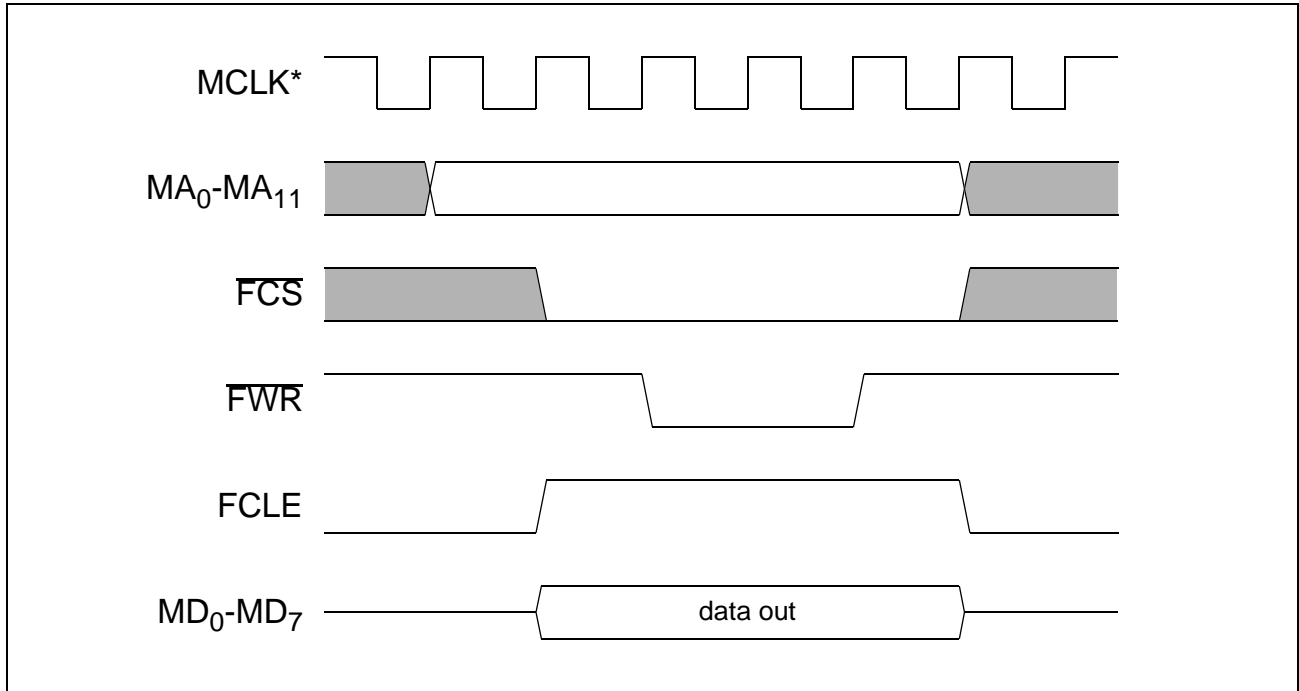

Figure 50 Flash Memory Interface - Command Write

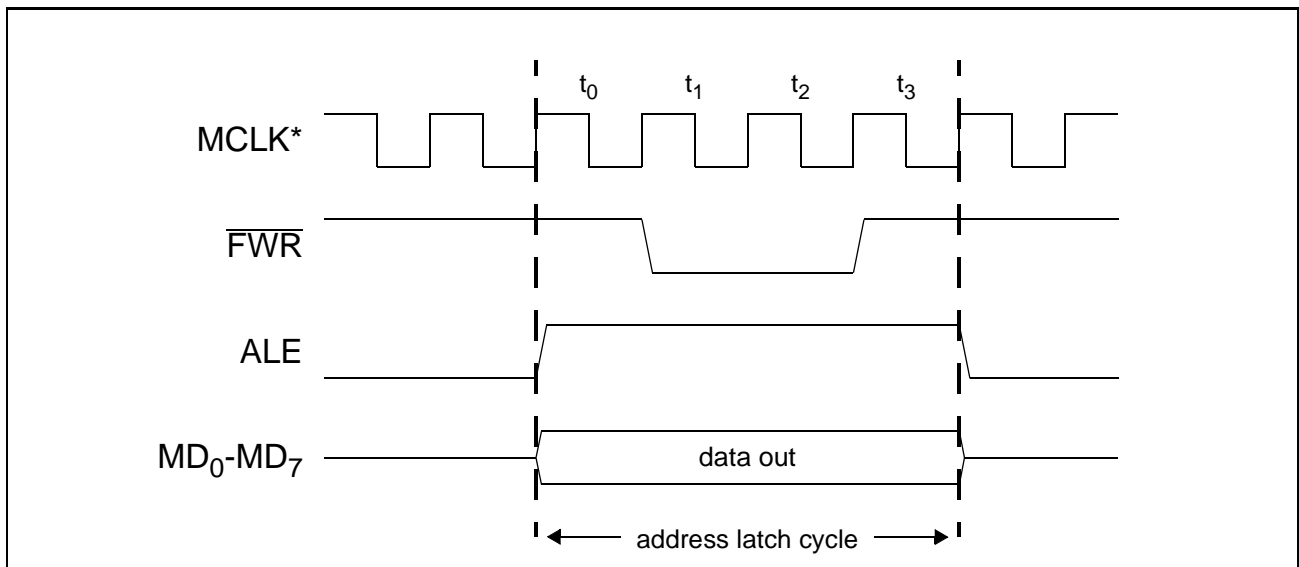

Figure 51 Flash Memory Interface - Address Write

As there is no access that starts or stops with an address write cycle (figure 51) \overline{FCS} is already low at the start of this cycle and also remains low.

Functional Description

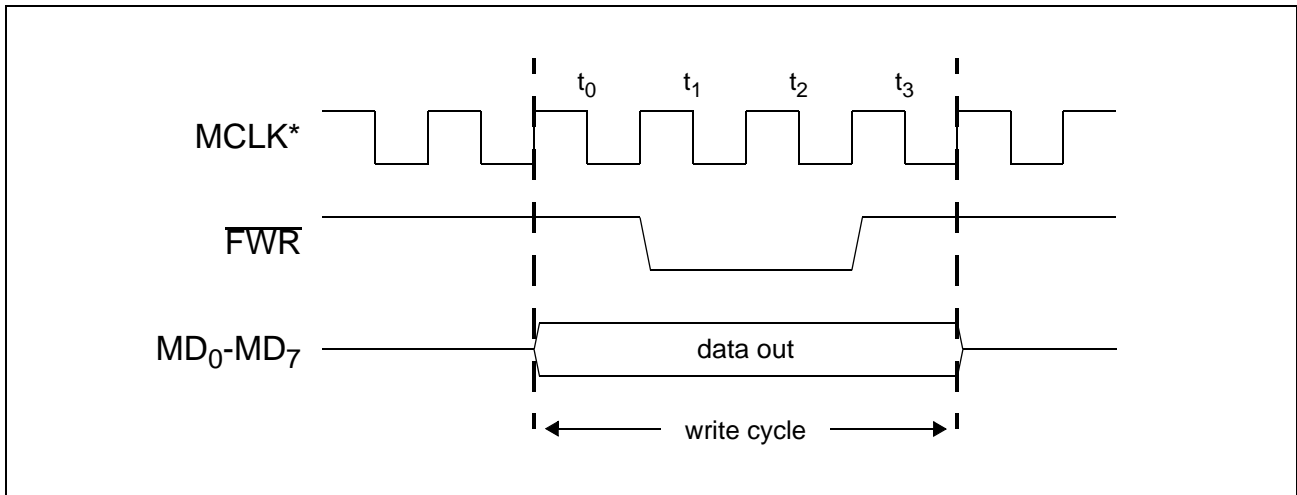

Figure 52 Flash Memory Interface - Data Write

As there is no access that starts or stops with a data write cycle (figure 52) \overline{FCS} is already low at the start of this cycle and also remains low.

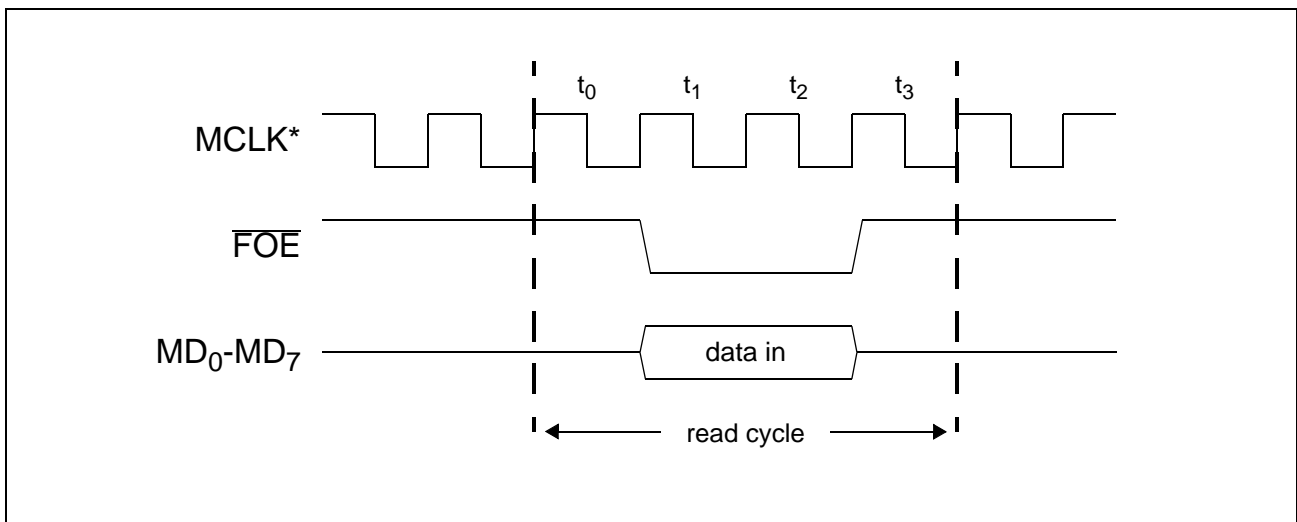

Figure 53 Flash Memory Interface - Data Read

If the device access ends with a read cycle, the \overline{FCS} -signals go inactive after t_3 of the last read cycle. The data is latched at the rising edge of \overline{FOE} .

Functional Description

2.4.5 Auxiliary Parallel Port

The PSB 2168 provides an auxiliary parallel port if the memory interface is in Samsung mode and only one device is used. In this case the lines MA₀ to MA₁₅ are not needed for the memory interface and can therefore be used for an auxiliary parallel port. This port has two modes: static mode and multiplex mode.

2.4.5.1 Static Mode

In static mode all pins of the auxiliary parallel port interface have identical functionality. Any pin can be configured as an output or an input. Pins configured as outputs provide a static signal as programmed by the controller. Pins configured as inputs are monitoring the signal continuously without latching. The controller always reads the current value. Table 71 shows the registers used for static mode.

Table 71 Static Mode Registers

| Register | # of bits | Comment |
|----------|-----------|---|
| DOUT3 | 16 | Output signals (for pins configured as outputs) |
| DIN | 16 | Input signals (for pins configured as inputs) |
| DDIR | 16 | Pin direction |

2.4.5.2 Multiplex Mode

In multiplex mode, the PSB 2168 uses MA₁₂-MA₁₅ to distinguish four timeslots. Each timeslot has a duration of approximately 2 ms. The timeslots are separated by a gap of approximately 125 μs in which none of the signals at MA₁₂-MA₁₅ are active. The PSB 2168 multiplexes three more output registers to MA₀-MA₁₁ in timeslots 0, 1 and 2. In timeslot 3 the direction of the pins can be programmed. For input pins, the signal is latched at the falling edge of MA₁₅. Table 72 shows the registers used for multiplex mode.

This mode is useful for scanning keys or controlling seven segment LED displays.

Table 72 Multiplex Mode Registers

| Register | # of bits | Comment |
|----------|-----------|---|
| DOUT0 | 12 | Output signals on MA ₀ -MA ₁₁ while MA ₁₅ =1 |
| DOUT1 | 12 | Output signals on MA ₀ -MA ₁₁ while MA ₁₄ =1 |
| DOUT2 | 12 | Output signals on MA ₀ -MA ₁₁ while MA ₁₃ =1 |
| DOUT3 | 12 | Output signals (for pins configured as outputs) while MA ₁₂ =1 |
| DIN | 12 | Input signals (for pins configured as inputs) at falling edge of MA ₁₂ |
| DDIR | 12 | Pin direction during MA ₁₂ =1 |

Functional Description

Figure 54 shows the timing diagram for multiplex mode.

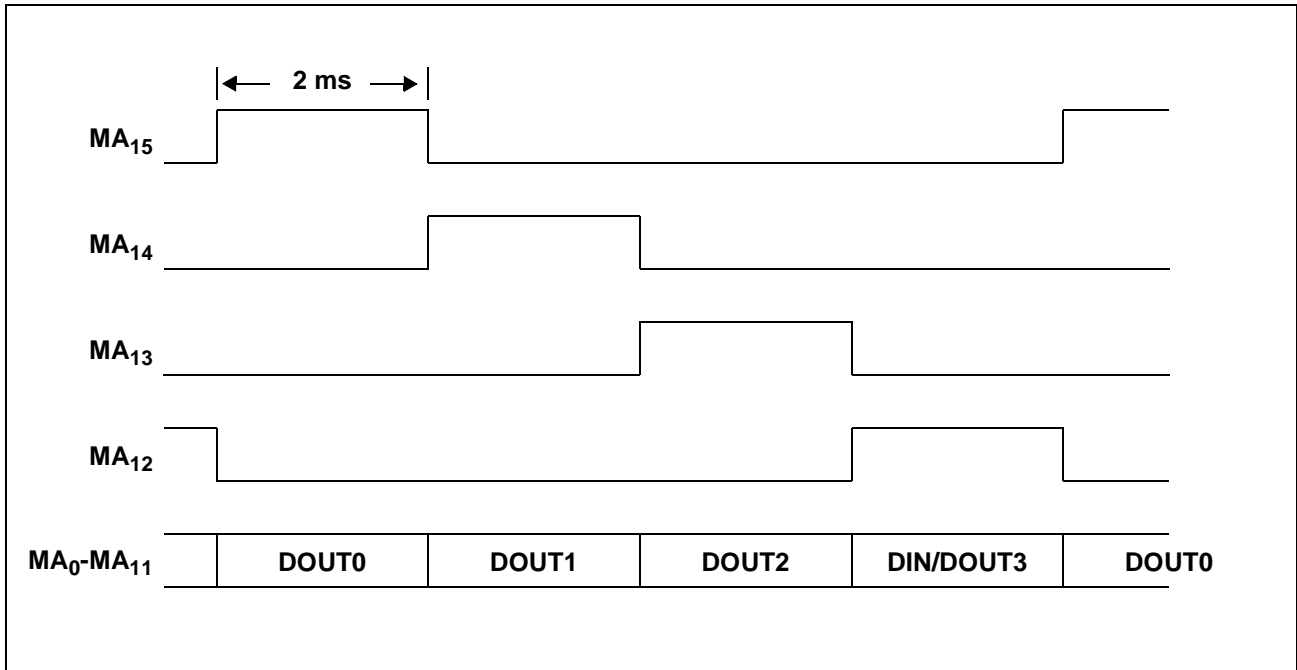

Figure 54 Auxiliary Parallel Port - Multiplex Mode

Note: In either mode the voltage at any pin (MA₀ to MA₁₅) must not exceed V_{DD}.

Detailed Register Description

3 Detailed Register Description

The PSB 2168 has a single status register (read only) and an array of data registers (read/write). The purpose of the status register is to inform the external microcontroller of important status changes of the PSB 2168 and to provide a handshake mechanism for data register reading or writing. If the PSB 2168 generates an interrupt, the status register contains the reason of the interrupt.

3.1 Status Register

| | | | | | | | | | | | | | | | | |
|-----------|-----|---|---|-----|----|-----|-----|----|-----|-----|-----|-----|---------------|---------------|---------------|--|
| 15 | | | | | | | | | | | | | | 0 | | |
| RDY | ABT | 0 | 0 | CIA | CD | CPT | CNG | SD | ERR | BSY | DTV | ATV | ¹⁾ | ¹⁾ | ¹⁾ | |

¹⁾ undefined

RDY **Ready**

- 0: The last command (if any) is still in progress.
- 1: The last command has been executed.

ABT **Abort**

- 0: No exception during operation
- 1: Some exception other than reset caused the PSB 2168 to abort any operation currently in progress. The external microcontroller should reinitialize the PSB 2168 to ensure proper operation. The ABT bit is cleared by writing any value to register REV. No other command is accepted by the PSB 2168 while ABT is set.

CIA **Caller ID Available**

- 0: No new data for caller ID
- 1: New caller ID byte available

CD **Carrier Detect**

- 0: No carrier detected
- 1: Carrier detected

Detailed Register Description**CPT Call Progress Tone**

- 0: Currently no call progress tone detected or pause detected (raw mode)
- 1: Currently a call progress is detected

CNG Fax Calling Tone

- 0: Currently no fax calling tone detected
- 1: Currently a fax calling tone is detected

SD Speech Detected

- 0: No speech detected
- 1: Speech signal at input of coder

ERR Error (File Command)

- 0: No error
- 1: Last file command resulted in an error

BSY Busy (File Command)

- 0: File system idle
- 1: File system still busy (also set during encoding/decoding)

DTV DTMF Tone Valid

- 0: No new DTMF code available
- 1: New DTMF code available in DDCTL

ATV Alert Tone Valid

- 0: No new alert tone code available
- 1: New alert tone code available in ADCTL0

Detailed Register Description

3.2 Hardware Configuration Registers

HWCONFIG 0 - Hardware Configuration Register 0

| | | | | | | | |
|----|---|-----|-----|-------|---------------------------|-------|-------|
| 7 | | | | | | | 0 |
| PD | 0 | RTC | OSC | PPSDI | $\overline{\text{PFRDY}}$ | PPINT | PPSDX |

PPSDX Push/Pull for SDX

- 0: The SDX pin has open-drain characteristic
- 1: The SDX pin has push/pull characteristic

PPINT Push/Pull for $\overline{\text{INT}}$

- 0: The $\overline{\text{INT}}$ pin has open-drain characteristic
- 1: The $\overline{\text{INT}}$ pin has push/pull characteristic

$\overline{\text{PFRDY}}$ Pullup for FRDY

- 0: The internal pullup resistor of pin $\overline{\text{FRDY}}$ is enabled
- 1: The internal pullup resistor of $\overline{\text{FRDY}}$ is disabled

PPSDI Push/Pull for SDI interface

- 0: The DU and DD pins have open-drain characteristic
- 1: The DU and DD pins have push/pull characteristic

OSC Enable Auxiliary Oscillator

- 0: The auxiliary oscillator (OSC₁, OSC₂) is disabled
- 1: The auxiliary oscillator (OSC₁, OSC₂) is enabled

RTC Enable Real Time Clock

- 0: The real time clock is disabled
- 1: The real time clock (RTC) is enabled.

PD Power Down (read only)

- 0: The PSB 2168 is in active mode
- 1: The PSB 2168 is in power down mode

Detailed Register Description

HWCONFIG 1 - Hardware Configuration Register 1

| | | | | |
|-----|---|---|---|------|
| 7 | 0 | 0 | 1 | 0 |
| APP | 0 | 0 | 1 | XTAL |
| | | | | SSDI |

APP Auxiliary Parallel Port

| 7 | 6 | Description |
|---|---|--|
| 0 | 0 | normal (ARAM/DRAM, Intel type flash, voice prompt EPROM) |
| 0 | 1 | APP static mode |
| 1 | 0 | APP multiplex mode |
| 1 | 1 | reserved |

XTAL XTAL Frequency

| 2 | 1 | Factor p ¹⁾ | Description |
|---|---|------------------------|-------------|
| 0 | 0 | reserved | reserved |
| 0 | 1 | 4.5 | 31.104 MHz |
| 1 | 0 | 4 | 27.648 MHz |
| 1 | 1 | reserved | reserved |

¹⁾ The factor p is needed to calculate the clock frequency at AFECLK.

SSDI SSDI Interface Selection

- 0: IOM[®]-2 Interface
- 1: SSDI Interface

Detailed Register Description

HWCONFIG 2 - Hardware Configuration Register 2

| | | | | | | |
|-----|------|------|---|---|--|------|
| 7 | | | | | | 0 |
| PPM | ESDX | ESDR | 0 | 0 | | RSEL |

PPM Push/Pull for Memory Interface (reset, power down)

- 0: The signals for the memory interface have push/pull characteristic
- 1: The signals for the memory interface have pullup/pulldown characteristic

ESDX Edge Select for DX

- 0: DX is transmitted with the rising edge of DCL
- 1: DX is transmitted with the falling edge of DCL

ESDR Edge Select for DR

- 0: DR is latched with the falling edge of DCL
- 1: DR is latched with the rising edge of DCL

RSEL Refresh Select

| 1 | 0 | Description |
|---|---|--------------------------|
| 0 | 0 | 64 kHz refresh frequency |
| 0 | 1 | 32 kHz refresh frequency |
| 1 | 0 | 16 kHz refresh frequency |
| 1 | 1 | 8 kHz refresh frequency |

Detailed Register Description

HWCONFIG 3 - Hardware Configuration Register 3

| | | | | | | | |
|----------|---|---|---|---|---|-----|----------|
| 7 | | | | | | | 0 |
| 0 | 0 | 0 | 0 | 0 | 0 | CM1 | CM0 |

CM1 Clock Master 1

0: Clock generation at AFEFS and AFECLK disabled

1: Clock generation at AFEFS and AFECLK enabled

CM0 Clock Master 0

0: 512 kHz (AFECLK)

1: 1.536 MHz (AFECLK)

Detailed Register Description

3.3 Read/Write Registers

The following sections contains all read/write registers of the PSB 2168. The register addresses are given as hexadecimal values. Registers marked with an R are affected by reset or a wake up after power down. All other registers retain their previous value. No access must be made to addresses other than those associated with a read/write register.

Furthermore parameters of a functional unit must not be altered while the unit is enabled. Parameters that can be changed on the fly (taking effect while the functional unit is enabled) are marked individually.

3.3.1 Register Table

| Address. | Name | Long Name | Page |
|----------|---------|---|------|
| 00h | REV | Revision..... | 96 |
| 01h R | CCTL | Chip Control | 97 |
| 02h R | INTM | Interrupt Mask Register | 98 |
| 0Ah R | SDCONF | Serial Data Interface Configuration | 99 |
| 0Bh R | SDCHN1 | Serial Data Interface Channel 1 | 100 |
| 0Ch R | IFS3 | Interface Select 3 | 102 |
| 0Dh R | SDCHN2 | Serial Data Interface Channel 2 | 103 |
| 0Eh R | IFS4 | Interface Select 4 | 104 |
| 0Fh R | IFG5 | Interface Gain 5..... | 105 |
| 10h R | UA | Universal Attenuator..... | 106 |
| 11h R | DGCTL | DTMF Generator Control..... | 107 |
| 12h | DGF1 | DTMF Generator Frequency 1 | 108 |
| 13h | DGF2 | DTMF Generator Frequency 2 | 109 |
| 14h | DGL | DTMF Generator Level..... | 110 |
| 15h | DGATT | DTMF Generator Attenuation | 111 |
| 16h R | CNGCTL | Calling Tone Control..... | 112 |
| 17h | CNGBT | CNG Burst Time | 113 |
| 18h | CNGLEV | CNG Minimal Signal Level | 114 |
| 19h | CNGRES | CNG Signal Resolution | 115 |
| 1Ah R | ATDCTL0 | Alert Tone Detection 0..... | 116 |
| 1Bh | ATDCTL1 | Alert Tone Detection 1..... | 117 |
| 1Ch R | CIDCTL0 | Caller ID Control 0..... | 118 |
| 1Dh | CIDCTL1 | Caller ID Control 1 | 119 |
| 20h R | CPTCTL | Call Progress Tone Control | 120 |
| 21h | CPTTR | Call Progress Tone Thresholds..... | 121 |
| 22h | CPTMN | CPT Minimum Times..... | 122 |
| 23h | CPTMX | CPT Maximum Times..... | 123 |
| 24h | CPTDT | CPT Delta Times | 124 |
| 25h R | LECCTL | Line Echo Cancellation Control | 125 |

Detailed Register Description

| | | | |
|-------|--------|---|-----|
| 26h | LECLEV | Minimal Signal Level for Line Echo Cancellation | 126 |
| 27h | LECATT | Externally Provided Attenuation | 127 |
| 28h | LECMGN | Margin for Double Talk Detection | 128 |
| 29h R | DDCTL | DTMF Detector Control | 129 |
| 2Ah | DDTW | DTMF Detector Signal Twist | 130 |
| 2Bh | DDLEV | DTMF Detector Minimum Signal Level..... | 131 |
| 2Eh R | FCFCTL | Equalizer Control..... | 132 |
| 2Fh | FCFCOF | Equalizer Coefficient Data..... | 134 |
| 30h R | SCCTL | Speech Coder Control..... | 135 |
| 31h | SCCT2 | Speech Coder Control 2..... | 136 |
| 32h | SCCT3 | Speech Coder Control 3..... | 137 |
| 34h R | SDCTL | Speech Decoder Control..... | 138 |
| 38h R | AGCCTL | AGC Control..... | 139 |
| 39h R | AGCATT | Automatic Gain Control Attenuation | 140 |
| 3Ah | AGC1 | Automatic Gain Control 1 | 141 |
| 3Bh | AGC2 | Automatic Gain Control 2 | 142 |
| 3Ch | AGC3 | Automatic Gain Control 3 | 143 |
| 3Dh | AGC4 | Automatic Gain Control 4 | 144 |
| 3Eh | AGC5 | Automatic Gain Control 5 | 145 |
| 40h R | FCTL | File Control..... | 146 |
| 41h R | FCMD | File Command..... | 147 |
| 42h R | FDATA | File Data..... | 149 |
| 43h R | FPTR | File Pointer | 150 |
| 47h R | SPSCTL | SPS Control..... | 151 |
| 48h R | RTC1 | Real Time Clock 1 | 152 |
| 49h R | RTC2 | Real Time Clock 2..... | 153 |
| 4Ah R | DOUT0 | Data Out (Timeslot 0) | 154 |
| 4Bh R | DOUT1 | Data Out (Timeslot 1) | 155 |
| 4Ch R | DOUT2 | Data Out (Timeslot 2) | 156 |
| 4Dh R | DOUT3 | Data Out (Timeslot 3 or Static Mode)..... | 157 |
| 4Eh | DIN | Data In (Timeslot 3 or Static Mode)..... | 158 |
| 4Fh R | DDIR | Data Direction (Timeslot 3 or Static Mode) | 159 |

Note: Registers CCTL, FCTL, FCMD, FDATA, FPTR, RTC1, RTC2, DOUT0, DOUT1, DOUT2, DOUT3 and DDIR are only affected by reset, not by wakeup. For register SPSCTL see the register description for the exact behaviour.

3.3.2 Register Naming Conventions

Several registers contain one or more fields for input signal selection. All fields labelled I_1 (I_2 , I_3) are five bits wide and use the same coding as shown in table 73.

Detailed Register Description

Table 73 Signal Encoding

| 4 | 3 | 2 | 1 | 0 | Signal | Description |
|----------|----------|----------|----------|----------|-----------------|------------------------------------|
| 0 | 0 | 0 | 0 | 0 | S ₀ | Silence |
| 0 | 0 | 0 | 0 | 1 | S ₁ | Reserved |
| 0 | 0 | 0 | 1 | 0 | S ₂ | Reserved |
| 0 | 0 | 0 | 1 | 1 | S ₃ | Reserved |
| 0 | 0 | 1 | 0 | 0 | S ₄ | Reserved |
| 0 | 0 | 1 | 0 | 1 | S ₅ | Serial interface input, channel 1 |
| 0 | 0 | 1 | 1 | 0 | S ₆ | Serial interface output, channel 1 |
| 0 | 0 | 1 | 1 | 1 | S ₇ | Serial interface input, channel 2 |
| 0 | 1 | 0 | 0 | 0 | S ₈ | Serial interface output, channel 2 |
| 0 | 1 | 0 | 0 | 1 | S ₉ | DTMF generator output |
| 0 | 1 | 0 | 1 | 0 | S ₁₀ | DTMF generator auxiliary output |
| 0 | 1 | 0 | 1 | 1 | S ₁₁ | Reserved |
| 0 | 1 | 1 | 0 | 0 | S ₁₂ | Reserved |
| 0 | 1 | 1 | 0 | 1 | S ₁₃ | Speech decoder output |
| 0 | 1 | 1 | 1 | 0 | S ₁₄ | Universal attenuator output |
| 0 | 1 | 1 | 1 | 1 | S ₁₅ | Line echo canceller output |
| 1 | 0 | 0 | 0 | 0 | S ₁₆ | AGC unit output (after AGC) |
| 1 | 0 | 0 | 0 | 1 | S ₁₇ | AGC unit output (before AGC) |
| 1 | 0 | 0 | 1 | 0 | S ₁₈ | Equalizer output |
| 1 | 0 | 0 | 1 | 1 | | reserved |
| 1 | 0 | 1 | - | - | | reserved |
| 1 | 1 | - | - | - | | reserved |

Detailed Register Description

00_h **REV** **Revision**

| | | | | | | | | | | | | | | | |
|-----------|---|---|---|---|---|---|---|---|---|---|---|---|---|----------|---|
| 15 | | | | | | | | | | | | | | 0 | |
| 0 | 0 | 1 | 0 | 0 | 0 | 0 | 0 | 0 | 0 | 0 | 0 | 0 | 0 | 0 | 0 |

The revision register can only be read. For the PSB 2168, V2.1, all bits except bit 13 are zero.

Note: A write access to the revision register does not alter its content. It does, however, reset the ABT bit of the STATUS register.

Detailed Register Description

01_h CCTL Chip Control

| | | | | | | | | | | | | | | | |
|-------------|---|---|---|----|---|---|----|---|---|---|----|----|-----|-----|----------|
| 15 | | | | | | | | | | | | | | | 0 |
| 0 | 0 | 0 | 0 | MV | 0 | 0 | PD | 0 | 0 | 0 | MQ | MT | CS9 | SAS | |
| Reset Value | | | | | | | | | | | | | | | |
| 0 | 0 | 0 | 0 | 0 | 0 | 0 | 0 | 0 | 0 | 0 | 0 | 0 | 0 | 0 | 0 |

MV Voice Prompt Directory
 0: not available
 1: available (within EPROM or Flash)

PD Power Down
 0: PSB 2168 is in active mode
 1: enter power-down mode

MQ Memory Quality
 0: ARAM
 1: DRAM

MT Memory Type

| 3 | 2 | Description |
|---|---|----------------------|
| 0 | 0 | ARAM/DRAM |
| 1 | 1 | Samsung flash memory |

CS9 CAS selection
 0: other memory
 1: 256kx4 or 512kx8 memory

SAS Split Address Space
 0: other ARAM/DRAM
 1: two 2Mx8 devices

Detailed Register Description

02_h INTM Interrupt Mask Register

| | | | | | | | | | | | | | | | |
|-------------|---|---|---|-----|----|-----|-----|----|---|-----|-----|-----|----------|---|---|
| 15 | | | | | | | | | | | | | 0 | | |
| RDY | 1 | 0 | 0 | CIA | CD | CPT | CNG | SD | 0 | BSY | DTV | ATV | 0 | 0 | 0 |
| Reset Value | | | | | | | | | | | | | | | |
| 0 | 1 | 0 | 0 | 0 | 0 | 0 | 0 | 0 | 0 | 0 | 0 | 0 | 0 | 0 | 0 |

If a bit of this register is reset (set to 0), the corresponding bit of the status register does not generate an interrupt.

If a bit is set (set to 1), an external interrupt can be generated by the corresponding bit of the status register.

|

Detailed Register Description

0A_h SDCONF Serial Data Interface Configuration

| | | | | | | | | | | | | | | |
|-------------|---|-----|--|--|--|--|---|---|---|---|---|-----|---|----|
| 15 | | | | | | | | | | 0 | | | | |
| 0 | 0 | NTS | | | | | 0 | 0 | 0 | 0 | 0 | DCL | 0 | EN |
| Reset Value | | | | | | | | | | | | | | |
| 0 | 0 | 0 | | | | | 0 | 0 | 0 | 0 | 0 | 0 | 0 | 0 |

NTS Number of Timeslots

| 13 | 12 | 11 | 10 | 9 | 8 | Description |
|-----|-----|-----|-----|-----|-----|-------------|
| 0 | 0 | 0 | 0 | 0 | 0 | 1 |
| 0 | 0 | 0 | 0 | 0 | 1 | 2 |
| ... | ... | ... | ... | ... | ... | ... |
| 1 | 1 | 1 | 1 | 1 | 1 | 64 |

DCL Double Clock Mode

- 0: Single Clock Mode
- 1: Double Clock Mode

EN Enable Interface

- 0: Interface is disabled (both channels)
- 1: Interface is enabled (depending on separate channel enable bits)

Detailed Register Description

0B_h SDCHN1 Serial Data Interface Channel 1

15

0

| | | | | | | | |
|-----|---|---|-----|----|-----|----|----|
| NAS | 0 | 0 | PCD | EN | PCM | DD | TS |
|-----|---|---|-----|----|-----|----|----|

Reset Value

| | | | | | | | |
|---|---|---|---|---|---|---|---|
| 0 | 0 | 0 | 0 | 0 | 0 | 0 | 0 |
|---|---|---|---|---|---|---|---|

NAS Number of active DRST strobe (SSDI interface mode)

| 15 | 14 | 13 | 12 | Description |
|-----|-----|-----|-----|-------------|
| 0 | 0 | 0 | 0 | 1 |
| ... | ... | ... | ... | ... |
| 1 | 1 | 1 | 1 | 16 |

PCD PCM Code

0: A-law

1: μ -law

EN Enable Interface

0: Interface is disabled

1: Interface is enabled if SDCONF:EN=1

PCM PCM Mode

0: 16 Bit Linear Coding (two timeslots)

1: 8 Bit PCM Coding (one timeslot)

DD Data Direction

0: DD: Data Downstream, DU: Data Upstream

1: DD: Data Upstream, DU: Data Downstream

TS Timeslot for Channel 1

| 5 | 4 | 3 | 2 | 1 | 0 | Description |
|-----|-----|-----|-----|-----|-----|-------------|
| 0 | 0 | 0 | 0 | 0 | 0 | 0 |
| ... | ... | ... | ... | ... | ... | ... |
| 1 | 1 | 1 | 1 | 1 | 1 | 63 |

Detailed Register Description

*Note: If PCM=0 then TS denotes the first timeslot of the two consecutive timeslots used.
Only even timeslots are allowed in this case.*

Detailed Register Description

0C_h IFS3 Interface Select 3

| | | | |
|-------------|----|----|----------|
| 15 | | | 0 |
| HP | I1 | I2 | I3 |
| Reset Value | | | |
| 0 | 0 | 0 | 0 |

HP High-Pass for S₅

0: Disabled

1: Enabled

I1 Input signal 1 for S₆

I2 Input signal 2 for S₆

I3 Input signal 3 for S₆

Note: As all sources are always active, unused sources must be set to 0 (S₀).

Detailed Register Description

0D_h SDCHN2 Serial Data Interface Channel 2

15 0

| | | | | | | | | | | |
|---|---|---|---|---|---|-----|----|-----|----|----|
| 0 | 0 | 0 | 0 | 0 | 0 | PCD | EN | PCM | DD | TS |
|---|---|---|---|---|---|-----|----|-----|----|----|

Reset Value

| | | | | | | | | | | |
|---|---|---|---|---|---|---|---|---|---|---|
| 0 | 0 | 0 | 0 | 0 | 0 | 0 | 0 | 0 | 0 | 0 |
|---|---|---|---|---|---|---|---|---|---|---|

PCD PCM Code

- 0: A-law
- 1: μ -law

EN Enable Interface

- 0: Interface is disabled
- 1: Interface is enabled if SDCONF:EN=1

PCM PCM Mode

- 0: 16 Bit Linear Coding (two timeslots)
- 1: 8 Bit PCM Coding (one timeslot)

DD Data Direction

- 0: DD: Data Downstream, DU: Data Upstream
- 1: DD: Data Upstream, DD: Data Downstream

TS Timeslot for Channel 2

| 5 | 4 | 3 | 2 | 1 | 0 | Description |
|-----|-----|-----|-----|-----|-----|-------------|
| 0 | 0 | 0 | 0 | 0 | 0 | 0 |
| 0 | 0 | 0 | 0 | 0 | 1 | 1 |
| ... | ... | ... | ... | ... | ... | ... |
| 1 | 1 | 1 | 1 | 1 | 1 | 63 |

Note: If PCM=0 then TS denotes the first timeslot of the two consecutive timeslots used. Only even timeslots are allowed in this case.

Detailed Register Description

0E_h IFS4 Interface Select 4

| | | | |
|-------------|----|----|----------|
| 15 | | | 0 |
| HP | I1 | I2 | I3 |
| Reset Value | | | |
| 0 | 0 | 0 | 0 |

HP High-Pass for S₇

0: Disabled

1: Enabled

I1 Input signal 1 for S₈

I2 Input signal 2 for S₈

I3 Input signal 3 for S₈

As all sources are always active, unused sources must be set to 0 (S₀).

Detailed Register Description

0F_h IFG5 Interface Gain 5

| | |
|--------------------|--------------------|
| 15 | 0 |
| ATT1 ¹⁾ | ATT2 ¹⁾ |
| Reset Value | |
| 255 (0 dB) | 255 (0 dB) |

¹⁾ Can be changed on the fly.

ATT1 Attenuation for I3 (Channel 1)

In order to obtain an attenuation *A* the parameter ATT1 can be calculated by the following formula:

$$ATT1 = 256 \times 10^{A/20 \text{ dB}}$$

ATT2 Attenuation for I3 (Channel 2)

In order to obtain an attenuation *A* the parameter ATT2 can be calculated by the following formula:

$$ATT2 = 256 \times 10^{A/20 \text{ dB}}$$

Detailed Register Description

10_h UA Universal Attenuator

15 **0**

| | | | | |
|-------------------|---|---|---|----|
| ATT ¹⁾ | 0 | 0 | 0 | 11 |
|-------------------|---|---|---|----|

Reset Value

| | | | | |
|-------------|---|---|---|---|
| 0 (-100 dB) | 0 | 0 | 0 | 0 |
|-------------|---|---|---|---|

¹⁾ Can be changed on the fly.

ATT Attenuation for UA

For a given attenuation A [dB] the parameter ATT can be calculated by the following formula:

$$ATT = 256 \times 10^{A/20 \text{ dB}}$$

11 Input Selection for UA

Detailed Register Description

11_h DGCTL DTMF Generator Control

15 0

| | | | | | | | | | | | | | |
|----|----|---|---|---|---|---|---|---|---|---|---|---|-----|
| EN | MD | 0 | 0 | 0 | 0 | 0 | 0 | 0 | 0 | 0 | 0 | 0 | DTC |
|----|----|---|---|---|---|---|---|---|---|---|---|---|-----|

Reset Value

| | | | | | | | | | | | | | |
|---|---|---|---|---|---|---|---|---|---|---|---|---|---|
| 0 | 0 | 0 | 0 | 0 | 0 | 0 | 0 | 0 | 0 | 0 | 0 | 0 | 0 |
|---|---|---|---|---|---|---|---|---|---|---|---|---|---|

EN Generator Enable

- 0: Disabled
- 1: Enabled

MD Mode

- 0: raw
- 1: cooked

DTC Dial Tone Code (cooked mode)

| 3 | 2 | 1 | 0 | Digit | Frequency |
|---|---|---|---|-------|-----------|
| 0 | 0 | 0 | 0 | 1 | 697/1209 |
| 0 | 0 | 0 | 1 | 2 | 697/1336 |
| 0 | 0 | 1 | 0 | 3 | 697/1477 |
| 0 | 0 | 1 | 1 | A | 697/1633 |
| 0 | 1 | 0 | 0 | 4 | 770/1209 |
| 0 | 1 | 0 | 1 | 5 | 770/1336 |
| 0 | 1 | 1 | 0 | 6 | 770/1477 |
| 0 | 1 | 1 | 1 | B | 770/1633 |
| 1 | 0 | 0 | 0 | 7 | 852/1209 |
| 1 | 0 | 0 | 1 | 8 | 852/1336 |
| 1 | 0 | 1 | 0 | 9 | 852/1477 |
| 1 | 0 | 1 | 1 | C | 852/1633 |
| 1 | 1 | 0 | 0 | * | 941/1209 |
| 1 | 1 | 0 | 1 | 0 | 941/1336 |
| 1 | 1 | 1 | 0 | # | 941/1477 |
| 1 | 1 | 1 | 1 | D | 941/1633 |

Detailed Register Description

12_h DGF1 DTMF Generator Frequency 1

| | |
|-----------|----------|
| 15 | 0 |
| 0 | FRQ |

FRQ Frequency of Generator 1

The parameter FRQ for a given frequency f [Hz] can be calculated by the following formula:

$$FRQ = 32768 \times \frac{f}{4000\text{Hz}}$$

Detailed Register Description**13_h DGF2 DTMF Generator Frequency 2**

| | |
|-----------|----------|
| 15 | 0 |
| 0 | FRQ |

FRQ Frequency of Generator 2

The parameter FRQ for a given frequency f [Hz] can be calculated by the following formula:

$$\text{FRQ} = 32768 \times \frac{f}{4000\text{Hz}}$$

Detailed Register Description

14_h DGL DTMF Generator Level

| | | | |
|----|------|---|------|
| 15 | | 0 | |
| 0 | LEV2 | 0 | LEV1 |

LEV2 Signal Level of Generator 2

In order to obtain a signal level L (relative to the PCM maximum value) for generator 2 the value of LEV2 can be calculated according to the following formula:

$$\text{LEV2} = 128 \times 10^{L/20 \text{ dB}}$$

LEV1 Signal Level of Generator 1

In order to obtain a signal level L (relative to the PCM maximum value) for generator 1 the value of LEV1 can be calculated according to the following formula:

$$\text{LEV1} = 128 \times 10^{L/20 \text{ dB}}$$

Detailed Register Description

15_h DGATT DTMF Generator Attenuation

15

0

| | |
|------|------|
| ATT2 | ATT1 |
|------|------|

ATT2 Attenuation of Signal S₁₀

In order to obtain attenuation *A* the parameter ATT2 can be calculated by the formula:

$$ATT2 = \begin{cases} 128 + 1024 \times 10^{A/20 \text{ dB}} & ;A > 18, 1 \text{ dB} \\ 128 \times 10^{A/20 \text{ dB}} & ;A < 18, 1 \text{ dB} \end{cases}$$

ATT1 Attenuation of Signal S₉

In order to obtain attenuation *A* the parameter ATT1 can be calculated by the formula:

$$ATT1 = \begin{cases} 128 + 1024 \times 10^{A/20 \text{ dB}} & ;A > 18, 1 \text{ dB} \\ 128 \times 10^{A/20 \text{ dB}} & ;A < 18, 1 \text{ dB} \end{cases}$$

Detailed Register Description

16_h CNGCTL Calling Tone Control

15

0

| | | | | | | | | | | | | |
|----|---|---|---|---|---|---|---|---|---|---|---|----|
| EN | 0 | 0 | 0 | 0 | 0 | 0 | 0 | 0 | 0 | 0 | 0 | I1 |
|----|---|---|---|---|---|---|---|---|---|---|---|----|

Reset Value

| | | | | | | | | | | | | |
|---|---|---|---|---|---|---|---|---|---|---|---|---|
| 0 | 0 | 0 | 0 | 0 | 0 | 0 | 0 | 0 | 0 | 0 | 0 | 0 |
|---|---|---|---|---|---|---|---|---|---|---|---|---|

EN Enable

0: CNG unit disabled

1: CNG unit enabled

I1 Input Selection for Calling Tone Detector

Detailed Register Description

17_h CNGBT CNG Burst Time

| | |
|----|------|
| 15 | 0 |
| 0 | TIME |

TIME Minimum Time for Calling Tone

In order to obtain the parameter TIME for a minimum time *t* the following formula can be used:

$$\text{TIME} = t / 0.125 \text{ ms}$$

Detailed Register Description

18_h CNGLEV CNG Minimal Signal Level

| | | |
|----|---|-----|
| 15 | | 0 |
| 0 | 0 | MIN |

MIN Minimum Signal Level for Calling Tone

In order to obtain the parameter MIN for a minimum signal level L the following formula can be used:

$$MIN = 16384 \times 10^{L/20} \text{ dB}$$

Detailed Register Description

19_h CNGRES CNG Signal Resolution

| | | | | |
|-----------|---|---|---|----------|
| 15 | | | | 0 |
| 1 | 1 | 1 | 1 | RES |

RES Signal Resolution

The parameter RES depends on the noise level *L* as follows:

$$RES = -4096 \times 10^{L/20 \text{ dB}}$$

Detailed Register Description

1A_h ATDCTL0 Alert Tone Detection 0

15

0

| | | | | | | | | | | | |
|----|---|---|----|---|---|---|---|---|---|---|-----|
| EN | 0 | 0 | I1 | 0 | 0 | 0 | 0 | 0 | 0 | 0 | ATC |
|----|---|---|----|---|---|---|---|---|---|---|-----|

Reset Value

| | | | | | | | | | | | |
|---|---|---|---|---|---|---|---|---|---|---|-----------------|
| 0 | 0 | 0 | 0 | 0 | 0 | 0 | 0 | 0 | 0 | 0 | - ¹⁾ |
|---|---|---|---|---|---|---|---|---|---|---|-----------------|

¹⁾ undefined

EN Enable alert tone detection

0: The alert tone detection is disabled

1: The alert tone detection is enabled

I1 Input signal selection

ATC Alert Tone Code

| 1 | 0 | Description |
|---|---|-------------|
| 0 | 0 | no tone |
| 0 | 1 | 2130 |
| 1 | 0 | 2750 |
| 1 | 1 | 2130/2750 |

Detailed Register Description

1B_h ATDCTL1 Alert Tone Detection 1

15

0

| | | | | | | | | |
|----|---|---|-----|---|---|---|---|-----|
| MD | 0 | 0 | DEV | 0 | 0 | 0 | 0 | MIN |
|----|---|---|-----|---|---|---|---|-----|

MD Alert tone detection mode

- 0: Only dual tones will be detected
- 1: Either dual or single tones will be detected

DEV Maximum frequency deviation for alert tone

- 0: 0.5%
- 1: 1.1%

MIN Minimum level of alert tone signal

For a minimum signal level *min* the parameter MIN is given by the following formula:

$$MIN = 2560 \times 10^{\min/20 \text{ dB}}$$

Detailed Register Description

1C_h CIDCTL0 Caller ID Control 0

15

0

| | | | | |
|----|---|---|----|------|
| EN | 0 | 0 | I1 | DATA |
|----|---|---|----|------|

Reset Value

| | | | | |
|---|---|---|---|---|
| 0 | 0 | 0 | 0 | 0 |
|---|---|---|---|---|

EN CID Enable

0: Disabled

1: Enabled

I1 Input signal selection

DATA Last received data byte

Detailed Register Description

1D_h CIDCTL1 Caller ID Control 1

15 **0**

| | | |
|-----|------|-----|
| NMB | NMSS | MIN |
|-----|------|-----|

NMB Minimum Number of Mark Bits

| 15 | 14 | 13 | 12 | 11 | 10 | Description |
|-----|-----|-----|-----|-----|-----|-------------|
| 0 | 0 | 0 | 0 | 0 | 0 | 0 |
| 0 | 0 | 0 | | | 1 | 10 |
| ... | ... | ... | ... | ... | ... | ... |
| 1 | 1 | 1 | 1 | 1 | 1 | 630 |

NMSS Minimum Number of Mark/Space Sequences

| 9 | 8 | 7 | 6 | 5 | Description |
|-----|-----|-----|-----|-----|-------------|
| 0 | 0 | 0 | 0 | 0 | 1 |
| 0 | 0 | 0 | 0 | 1 | 11 |
| ... | ... | ... | ... | ... | |
| 1 | 1 | 1 | 1 | 1 | 311 |

MIN Minimum Signal Level for CID Decoder

For a minimum signal level *min* the parameter MIN is given by the following formula:

$$MIN = 640 \times 10^{\min/20 \text{ dB}}$$

Detailed Register Description

20_h CPTCTL Call Progress Tone Control

15

0

| | | | | | | | | | | | |
|----|----|---|---|---|---|---|---|---|---|---|----|
| EN | MD | 0 | 0 | 0 | 0 | 0 | 0 | 0 | 0 | 0 | I1 |
|----|----|---|---|---|---|---|---|---|---|---|----|

Reset Value

| | | | | | | | | | | | |
|---|---|---|---|---|---|---|---|---|---|---|---|
| 0 | 0 | 0 | 0 | 0 | 0 | 0 | 0 | 0 | 0 | 0 | 0 |
|---|---|---|---|---|---|---|---|---|---|---|---|

EN CPT Detector Enable

0: Disabled

1: Enabled

MD CPT Mode

0: raw

1: cooked

I1 Input signal selection

Detailed Register Description

21_h CPTTR Call Progress Tone Thresholds

15

0

| | | | |
|-----|---|----|-----|
| NUM | 0 | SN | MIN |
|-----|---|----|-----|

NUM Number of Cycles

| 15 | 14 | 13 | cooked mode | raw mode |
|-----|-----|-----|-------------|----------|
| 0 | 0 | 0 | reserved | 0 |
| 0 | 0 | 1 | 2 | reserved |
| ... | ... | ... | ... | reserved |
| 1 | 1 | 1 | 8 | reserved |

SN Minimal Signal-to-Noise Ratio

| 11 | 10 | 9 | 8 | Description |
|----|----|---|---|-------------|
| 1 | 1 | 1 | 1 | 9 dB |
| 1 | 0 | 0 | 0 | 12 dB |
| 0 | 1 | 0 | 0 | 15 dB |
| 0 | 0 | 1 | 0 | 18 dB |
| 0 | 0 | 0 | 0 | 22 dB |

MIN Minimum Signal Level for CPT Detector

| Value | Description |
|-----------------|-------------|
| 89 _h | -40 dB |
| 85 _h | -42 dB |
| 80 _h | -44 dB |
| 9A _h | -46 dB |
| 95 _h | -48 dB |
| 90 _h | -50 dB |

Detailed Register Description

22_h CPTMN CPT Minimum Times

| | |
|------|------|
| 15 | 0 |
| MINB | MING |

MINB Minimum Time for CPT Burst

The parameter MINB for a minimal burst time TB_{min} can be calculated by the following formula:

$$MINB = \frac{TB_{min} - 32 \text{ ms}}{4}$$

MING Minimum Time for CPT Gap

The parameter MING for a minimal burst time TG_{min} can be calculated by the following formula:

$$MING = \frac{TG_{min} - 32 \text{ ms}}{4}$$

Detailed Register Description

23_h CPTMX CPT Maximum Times

| | |
|------|------|
| 15 | 0 |
| MAXB | MAXG |

MAXB Maximum Time for CPT Burst

The parameter MAXB for a maximal burst time of *TBmax* can be calculated by the following formula:

$$MAXB = \frac{TB_{max} - TB_{min}}{8}$$

MAXG Maximum Time for CPT Gap

The parameter MAXG for a maximal burst time of *TGmax* can be calculated by the following formula:

$$MAXG = \frac{TG_{max} - TG_{min}}{8}$$

Detailed Register Description

24_h CPTDT CPT Delta Times

| | |
|------|------|
| 15 | 0 |
| DIFB | DIFG |

DIFB Maximum Time Difference between consecutive Bursts

The parameter DIFB for a maximal difference of t ms of two burst durations can be calculated by the following formula:

$$\text{DIFB} = \frac{t}{2 \text{ ms}}$$

DIFG Maximum Time Difference between consecutive Gaps

The parameter DIFG for a maximal difference of t ms of two gap durations can be calculated by the following formula:

$$\text{DIFG} = \frac{t}{2 \text{ ms}}$$

Detailed Register Description

25_h LECCTL Line Echo Cancellation Control

| | | | | | | | |
|-------------|----|---|---|---|---|----------|----|
| 15 | | | | | | 0 | |
| EN | MD | 0 | 0 | 0 | 0 | I1 | I2 |
| Reset Value | | | | | | | |
| 0 | 0 | 0 | 0 | 0 | 0 | 0 | 0 |

EN Enable

0: Disabled

1: Enabled

MD Mode

0: Normal

1: Extended

I1 Input signal selection for I₁

I2 Input signal selection for I₂

Detailed Register Description

26_h LECLEV Minimal Signal Level for Line Echo Cancellation

| | |
|-----------|----------|
| 15 | 0 |
| 0 | MIN |

MIN

The parameter MIN for a minimal signal level L (dB) can be calculated by the following formula:

$$MIN = \frac{512 \times (96.3 + L)}{5 \times \log 2}$$

Detailed Register Description**27_h LECATT Externally Provided Attenuation**

| | |
|-----------|----------|
| 15 | 0 |
| 0 | ATT |

ATT

The parameter ATT for an externally provided attenuation A (dB) can be calculated by the following formula:

$$ATT = \frac{512 \times A}{5 \times \log 2}$$

Detailed Register Description

28_h LECMGN Margin for Double Talk Detection

| | |
|----|-----|
| 15 | 0 |
| 0 | MGN |

MGN

The parameter MGN for a margin of L (dB) can be calculated by the following formula:

$$MGN = \frac{512 \times L}{5 \times \log 2}$$

Detailed Register Description

29_h DDCTL DTMF Detector Control

15

0

| | | | | | | | | | |
|----|---|---|----|--|--|---|---|---|-----|
| EN | 0 | 0 | I1 | | | 0 | 0 | 0 | DTC |
|----|---|---|----|--|--|---|---|---|-----|

Reset Value

| | | | | | | | | | |
|---|---|---|---|--|--|---|---|---|-----|
| 0 | 0 | 0 | 0 | | | 0 | 0 | 0 | _1) |
|---|---|---|---|--|--|---|---|---|-----|

¹⁾ undefined

EN Enable DTMF tone detection

0: The DTMF detection is disabled

1: The DTMF detection is enabled

I1 Input signal selection

DTC DTMF Tone Code

| 4 | 3 | 2 | 1 | 0 | Frequency | Digit |
|---|---|---|---|---|------------|-------|
| 1 | 0 | 0 | 0 | 0 | 941 / 1633 | D |
| 1 | 0 | 0 | 0 | 1 | 697 / 1209 | 1 |
| 1 | 0 | 0 | 1 | 0 | 697 / 1336 | 2 |
| 1 | 0 | 0 | 1 | 1 | 697 / 1477 | 3 |
| 1 | 0 | 1 | 0 | 0 | 770 / 1209 | 4 |
| 1 | 0 | 1 | 0 | 1 | 770 / 1336 | 5 |
| 1 | 0 | 1 | 1 | 0 | 770 / 1477 | 6 |
| 1 | 0 | 1 | 1 | 1 | 852 / 1209 | 7 |
| 1 | 1 | 0 | 0 | 0 | 852 / 1336 | 8 |
| 1 | 1 | 0 | 0 | 1 | 852 / 1477 | 9 |
| 1 | 1 | 0 | 1 | 0 | 941 / 1336 | 0 |
| 1 | 1 | 0 | 1 | 1 | 941 / 1209 | * |
| 1 | 1 | 1 | 0 | 0 | 941 / 1477 | # |
| 1 | 1 | 1 | 0 | 1 | 697 / 1633 | A |
| 1 | 1 | 1 | 1 | 0 | 770 / 1633 | B |
| 1 | 1 | 1 | 1 | 1 | 852 / 1633 | C |

Detailed Register Description

2A_h DDTW DTMF Detector Signal Twist

| | |
|-----------|----------|
| 15 | 0 |
| 0 | TWIST |

TWIST Signal twist for DTMF tone

In order to obtain a minimal signal twist T the parameter TWIST can be calculated by the following formula:

$$TWIST = 32768 \times 10^{(0.5 \text{ dB} - T) / 10 \text{ dB}}$$

Note: TWIST must be in the range [4096,20480]

Detailed Register Description

2B_h DDLEV DTMF Detector Minimum Signal Level

15

0

| | | | | | | | | | | | |
|---|---|---|---|---|---|---|---|---|---|---|-----|
| 1 | 1 | 1 | 1 | 1 | 1 | 1 | 1 | 1 | 1 | 1 | MIN |
|---|---|---|---|---|---|---|---|---|---|---|-----|

MIN Minimum Signal Level

| 5 | 4 | 3 | 2 | 1 | 0 | Description |
|-----|-----|-----|-----|-----|-----|-------------|
| 0 | 0 | 1 | 1 | 1 | 0 | -50 dB |
| 0 | 0 | 1 | 1 | 1 | 1 | -49 dB |
| ... | ... | ... | ... | ... | ... | ... |
| 1 | 0 | 0 | 0 | 0 | 1 | -31 dB |
| 1 | 0 | 0 | 0 | 1 | 0 | -30 dB |

Note: Values outside the given range are reserved and must not be used.

Detailed Register Description

2E_h FCFCTL Equalizer Control

15

0

| | | | | | | |
|----|---|-----|---|---|---|---|
| EN | 0 | ADR | 0 | 0 | 0 | 1 |
|----|---|-----|---|---|---|---|

Reset Value

| | | | | | | |
|---|---|---|---|---|---|---|
| 0 | 0 | 0 | 0 | 0 | 0 | 0 |
|---|---|---|---|---|---|---|

EN Enable equalizer

0: The equalizer is disabled

1: The equalizer is enabled

ADR Coefficient address

| 13 | 12 | 11 | 10 | 9 | 8 | Coefficient |
|----|----|----|----|---|---|-------------|
| 0 | 0 | 0 | 0 | 0 | 0 | A1 |
| 0 | 0 | 0 | 0 | 0 | 1 | A2 |
| 0 | 0 | 0 | 0 | 1 | 0 | A3 |
| 0 | 0 | 0 | 0 | 1 | 1 | A4 |
| 0 | 0 | 0 | 1 | 0 | 0 | A5 |
| 0 | 0 | 0 | 1 | 0 | 1 | A6 |
| 0 | 0 | 0 | 1 | 1 | 0 | A7 |
| 0 | 0 | 0 | 1 | 1 | 1 | A8 |
| 0 | 0 | 1 | 0 | 0 | 0 | A9 |
| 0 | 0 | 1 | 0 | 0 | 1 | B2 |
| 0 | 0 | 1 | 0 | 1 | 0 | B3 |
| 0 | 0 | 1 | 0 | 1 | 1 | B4 |
| 0 | 0 | 1 | 1 | 0 | 0 | B5 |
| 0 | 0 | 1 | 1 | 0 | 1 | B6 |
| 0 | 0 | 1 | 1 | 1 | 0 | B7 |
| 0 | 0 | 1 | 1 | 1 | 1 | B8 |
| 0 | 1 | 0 | 0 | 0 | 0 | B9 |
| 0 | 1 | 0 | 0 | 0 | 1 | C1 |
| 0 | 1 | 0 | 0 | 1 | 0 | D1 |
| 0 | 1 | 0 | 0 | 1 | 1 | D2 |
| 0 | 1 | 0 | 1 | 0 | 0 | D3 |
| 0 | 1 | 0 | 1 | 0 | 1 | D4 |
| 0 | 1 | 0 | 1 | 1 | 0 | D5 |

Detailed Register Description

| 13 | 12 | 11 | 10 | 9 | 8 | Coefficient |
|-----------|-----------|-----------|-----------|----------|----------|--------------------|
| 0 | 1 | 0 | 1 | 1 | 1 | D6 |
| 0 | 1 | 1 | 0 | 0 | 0 | D7 |
| 0 | 1 | 1 | 0 | 0 | 1 | D8 |
| 0 | 1 | 1 | 0 | 1 | 0 | D9 |
| 0 | 1 | 1 | 0 | 1 | 1 | D10 |
| 0 | 1 | 1 | 1 | 0 | 0 | D11 |
| 0 | 1 | 1 | 1 | 0 | 1 | D12 |
| 0 | 1 | 1 | 1 | 1 | 0 | D13 |
| 0 | 1 | 1 | 1 | 1 | 1 | D14 |
| 1 | 0 | 0 | 0 | 0 | 0 | D15 |
| 1 | 0 | 0 | 0 | 0 | 1 | D16 |
| 1 | 0 | 0 | 0 | 1 | 0 | D17 |
| 1 | 0 | 0 | 0 | 1 | 1 | C2 |

I1 Input signal selection

Detailed Register Description

2F_h FCFCOF Equalizer Coefficient Data

| | | |
|-----------|----------|----------|
| 15 | V | 0 |
|-----------|----------|----------|

V Coefficient value

For the coefficient A₁-A₉, B₂-B₉ and D₁-D₁₇ the following formula can be used to calculate V for a coefficient c:

$$V = 32768 \times c \quad ; -1 \leq c < 1$$

For the coefficients C₁ and C₂ the following formula can be used to calculate V for a coefficient c:

$$V = 128 \times c \quad ; 1 \leq c < 256$$

Detailed Register Description

30_h SCCTL Speech Coder Control

| | | | | | | | | |
|-------------|------------------|----|---|---|---|----|--|----------|
| 15 | | | | | | | | 0 |
| EN | HQ ¹⁾ | VC | 0 | 0 | 0 | I1 | | I2 |
| Reset Value | | | | | | | | |
| 0 | 0 | 0 | 0 | 0 | 0 | 0 | | 0 |

¹⁾ Can be changed on the fly.

EN Enable

0: Disabled

1: Enabled

HQ High Quality Mode

0: Long Play Mode

1: High Quality Mode

VC Voice Controlled Start of Recording

0: Disabled

1: Enabled

I1 Input signal selection (first input)

I2 Input signal selection (second input)

Detailed Register Description

31_h SCCT2 Speech Coder Control 2

| | |
|------|-----|
| 15 | 0 |
| TIME | MIN |

TIME

The parameter TIME for a time t ([ms]) can be calculated by the following formula:

$$\text{TIME} = \frac{t}{32}$$

MIN

The parameter MIN for a signal level L ([dB]) can be calculated by the following formula:

$$\text{MIN} = 16384 \times 10^{\frac{L}{20}}$$

Detailed Register Description

32_h SCCT3 Speech Coder Control 3

| | | | | | | | | | | |
|-----------|----|---|---|---|---|---|---|---|---|----------|
| 15 | | | | | | | | | | 0 |
| 0 | LP | 0 | 0 | 0 | 0 | 0 | 0 | 0 | 0 | 0 |

LP

The parameter LP for a time constant of t ([ms]) can be calculated by the following formula:

$$LP = \frac{256}{t}$$

Detailed Register Description

34_h SDCTL Speech Decoder Control

15

0

| | | | | | | | | | | | | | | |
|----|---|---|---|---|---|---|---|---|---|---|---|---|---|-------|
| EN | 0 | 0 | 0 | 0 | 0 | 0 | 0 | 0 | 0 | 0 | 0 | 0 | 0 | SPEED |
|----|---|---|---|---|---|---|---|---|---|---|---|---|---|-------|

Reset Value

| | | | | | | | | | | | | | | |
|---|---|---|---|---|---|---|---|---|---|---|---|---|---|---|
| 0 | 0 | 0 | 0 | 0 | 0 | 0 | 0 | 0 | 0 | 0 | 0 | 0 | 0 | 0 |
|---|---|---|---|---|---|---|---|---|---|---|---|---|---|---|

EN Enable

0: Disabled

1: Enabled

SPEED Playback Speed

| 1 | 0 | Description |
|---|---|------------------------|
| 0 | 0 | normal speed |
| 0 | 1 | 0.5 times normal speed |
| 1 | 0 | 1.5 times normal speed |
| 1 | 1 | 2.0 times normal speed |

Detailed Register Description

38_h AGCTL AGC Control

| | | | | | | | | | | | | |
|-------------|---|---|---|---|---|----|--|--|--|--|--|----------|
| 15 | | | | | | | | | | | | 0 |
| EN | 0 | 0 | 0 | 0 | 0 | I1 | | | | | | I2 |
| Reset Value | | | | | | | | | | | | |
| 0 | 0 | 0 | 0 | 0 | 0 | 0 | | | | | | 0 |

EN Enable

0: Disabled

1: Enabled

I1 Input signal selection for I₁

I2 Input signal selection for I₂

Detailed Register Description

39_h AGCATT Automatic Gain Control Attenuation

15

0

| |
|-----|
| ATT |
|-----|

Reset Value

| |
|-------------|
| 0 (-100 dB) |
|-------------|

ATT

The parameter ATT for an attenuation A ([dB]) can be calculated by the following formula:

$$ATT = 32768 \times 10^{\frac{A}{20}}$$

Detailed Register Description

3A_h AGC1 Automatic Gain Control 1

15

0

| | |
|-----|---------|
| COM | AG_INIT |
|-----|---------|

COM

The parameter COM for a signal level L ([dB]) can be calculated by the following formula:

$$COM = \begin{cases} 128 + 10^{\frac{L + 66,22}{20}} & ;L < -42,14 \text{ dB} \\ 10^{\frac{L + 42,14}{20}} & ;L > -42,14 \text{ dB} \end{cases}$$

AG_INIT

In order to obtain an initial gain G ([db]) the parameter AG_INIT can be calculated by the following formula:

$$AG_INIT = \begin{cases} 128 + 10^{\frac{G + 18,06}{20}} & ;G < 24 \text{ dB} \\ 10^{\frac{G - 6,02}{20}} & ;G > 24 \text{ dB} \end{cases}$$

Detailed Register Description

3B_h AGC2 Automatic Gain Control 2

15

0

| | |
|--------|--------|
| SPEEDL | SPEEDH |
|--------|--------|

SPEEDL

This parameter has no dimension. It controls the regulation speed of the AGC for signal levels below the comparator threshold (AGC1:COM). The higher the value the faster the AGC. Setting this parameter to 0 inhibits regulation.

SPEEDH

This parameter has no dimension. It controls the regulation speed of the AGC for signal levels above the comparator threshold (AGC1:COM). The higher the value the faster the AGC. Setting this parameter to 0 inhibits regulation.

Detailed Register Description

3C_h AGC3 Automatic Gain Control 3

| | | |
|-----------|-----|----------|
| 15 | | 0 |
| | MIN | MAX |

MIN

The parameter MIN for a gain G ([dB]) can be calculated by the following formula:

$$\text{MIN} = \begin{cases} 128 + 10^{\frac{G + 18,06}{20}} & ;G < 24 \text{ dB} \\ 10^{\frac{G - 6,02}{20}} & ;G > 24 \text{ dB} \end{cases}$$

MAX

The parameter MAX for an attenuation A ([dB]) can be calculated by the following formula:

$$\text{MAX} = 10^{\frac{A + 42,14}{20}}$$

Detailed Register Description

3D_h AGC4 Automatic Gain Control 4

| | |
|-----------|----------|
| 15 | 0 |
| DEC | LIM |

DEC

The parameter DEC for a time constant t ([1/ms]) is given by the following formula:

$$DEC = \frac{256}{t}$$

LIM

The parameter LIM for a signal level L ([dB]) can be calculated by the following formula:

$$LIM = \begin{cases} 128 + 10^{\frac{L + 90,3}{20}} & ;L < 66,22 \text{ dB} \\ 10^{\frac{L + 66,22}{20}} & ;L > 66,22 \text{ dB} \end{cases}$$

Detailed Register Description

3E_h AGC5 Automatic Gain Control 5

| | | | | | | | | | |
|-----------|---|---|---|---|---|---|---|---|----------|
| 15 | | | | | | | | | 0 |
| 0 | 0 | 0 | 0 | 0 | 0 | 0 | 0 | 1 | LP |

LP

The parameter LP for a time constant t ([1/ms]) is given by the following formula:

$$LP = \frac{16}{t}$$

Detailed Register Description

40_h FCTL File Control

15 **0**

| | | | | | | | | |
|---|----|----|----|---|---|---|---|-----|
| 0 | MD | MS | TS | 0 | 0 | 0 | 0 | FNO |
|---|----|----|----|---|---|---|---|-----|

Reset Value

| | | | | | | | | |
|---|---|---|---|---|---|---|---|---|
| 0 | 0 | 0 | 0 | 0 | 0 | 0 | 0 | 0 |
|---|---|---|---|---|---|---|---|---|

MD Mode

- 0: Audio Mode
- 1: Binary Mode

MS Memory Space

- 0: R/W Memory
- 1: Voice Prompt Directory

TS Time Stamp

- 0: no update of RTC1/RTC2 entry of file descriptor
- 1: RTC1/RTC2 entries are updated by content of RTC1/RTC2 registers.

FNO File Number

Detailed Register Description

41_h FCMD File Command

15 **0**

| | | | | | | | | | | | | |
|---|----|----|---|---|---|---|---|---|-----|-----|---|-----|
| 0 | IN | RD | 0 | 0 | 0 | 0 | 0 | 0 | ABT | EIE | 0 | CMD |
|---|----|----|---|---|---|---|---|---|-----|-----|---|-----|

Reset Value

| | | | | | | | | | | | | |
|---|---|---|---|---|---|---|---|---|---|---|---|---|
| 0 | 0 | 0 | 0 | 0 | 0 | 0 | 0 | 0 | 0 | 0 | 0 | 0 |
|---|---|---|---|---|---|---|---|---|---|---|---|---|

IN Initialize

- 0: no
- 1: yes (if CMD=1111)

RD Remap Directory

- 0: no
- 1: yes

ABT Abort Command

- 0: no
- 1: abort recompress

EIE Enable Immediate Execution

- 0: disabled (default, always possible)
- 1: enabled (restricted to certain commands and operating modes)

CMD File Command

| 4 | 3 | 2 | 1 | 0 | Description |
|---|---|---|---|---|------------------------------|
| 0 | 0 | 0 | 0 | 0 | Open File |
| 0 | 0 | 0 | 0 | 1 | Activate |
| 0 | 0 | 0 | 1 | 0 | Seek |
| 0 | 0 | 0 | 1 | 1 | Cut File |
| 0 | 0 | 1 | 0 | 0 | Read Data |
| 0 | 0 | 1 | 0 | 1 | Write Data |
| 0 | 0 | 1 | 1 | 0 | Memory Status |
| 0 | 0 | 1 | 1 | 1 | Recompress file |
| 0 | 1 | 0 | 0 | 0 | Read File Descriptor - User |
| 0 | 1 | 0 | 0 | 1 | Write File Descriptor - User |

Detailed Register Description

| 4 | 3 | 2 | 1 | 0 | Description |
|----------|----------|----------|----------|----------|-----------------------------|
| 0 | 1 | 0 | 1 | 0 | Read File Descriptor - RTC1 |
| 0 | 1 | 0 | 1 | 1 | Read File Descriptor - RTC2 |
| 0 | 1 | 1 | 0 | 0 | Read File Descriptor - LEN |
| 0 | 1 | 1 | 0 | 1 | Garbage Collection |
| 0 | 1 | 1 | 1 | 0 | Open Next Free File |
| 0 | 1 | 1 | 1 | 1 | Initialize |
| 1 | 0 | 0 | 0 | 0 | DMA Read |
| 1 | 0 | 0 | 0 | 1 | DMA Write |
| 1 | 0 | 0 | 1 | 0 | Erase Block |
| 1 | 0 | 0 | 1 | 1 | Set Address |
| 1 | 0 | 1 | - | - | reserved |
| 1 | 1 | 0 | - | - | reserved |
| 1 | 1 | 1 | - | - | reserved |

Detailed Register Description

42_h **FDATA** **File Data**

| | |
|-------------|---|
| 15 | 0 |
| FREE | |
| Reset Value | |
| 0 | |

The FDATA register contains the following information after a memory status command:

FREE Free Blocks

Number of blocks (1 kByte) currently usable for recording.

Detailed Register Description

43_h FPTR File Pointer

15

0

| | | | | | |
|--------------|---|---|---|---|-----------------|
| File Pointer | | | | | |
| 0 | 0 | 0 | 0 | 0 | Phrase selector |

Reset Value

| |
|---|
| 0 |
|---|

Detailed Register Description

47h SPSCTL SPS Control

15

0

| | | | | | | | | | | | |
|-----|---|---|---|---|---|---|---|---|------|-----|-----|
| POS | 0 | 0 | 0 | 0 | 0 | 0 | 0 | 0 | MODE | SP1 | SP0 |
|-----|---|---|---|---|---|---|---|---|------|-----|-----|

Reset Value

| | | | | | | | | | | | |
|---|---|---|---|---|---|---|---|---|---|-----|-----|
| 0 | 0 | 0 | 0 | 0 | 0 | 0 | 0 | 0 | 0 | _1) | _1) |
|---|---|---|---|---|---|---|---|---|---|-----|-----|

1) undefined

POS Position of Status Register Window

| 15 | 14 | 13 | 12 | SPS ₀ | SPS ₁ |
|-----|-----|-----|-----|------------------|------------------|
| 0 | 0 | 0 | 0 | Bit 0 | Bit 1 |
| 0 | 0 | 0 | 1 | Bit 1 | Bit 2 |
| ... | ... | ... | ... | ... | ... |
| 1 | 1 | 1 | 0 | Bit 14 | Bit 15 |

MODE Mode of SPS Interface

| 4 | 3 | 2 | Description |
|---|---|---|---|
| 0 | 0 | 0 | Disabled (SPS ₀ and SPS ₁ zero) |
| 0 | 0 | 1 | Output of SP1 and SP0 |
| 1 | 0 | 1 | Expanded address output |
| 1 | 1 | 0 | Output of STATUS register |

SP1 Direct Control for SPS₁

0: SPS₁ set to 0

1: SPS₁ set to 1

SP0 Direct Control for SPS₀

0: SPS₀ set to 0

1: SPS₀ set to 1

Note: If mode 1 has been selected prior to power-down, both mode 1 and the values of SP1 and SP0 are retained during power-down and wake-up. Other modes are reset to 0 during power down.

Detailed Register Description

48_h RTC1 Real Time Clock 1

15

0

| | | | | | |
|---|---|---|---|-----|-----|
| 0 | 0 | 0 | 0 | MIN | SEC |
|---|---|---|---|-----|-----|

Reset Value

| | | | | | |
|---|---|---|---|---|---|
| 0 | 0 | 0 | 0 | 0 | 0 |
|---|---|---|---|---|---|

MIN Minutes

Number of minutes elapsed in the current hour (0-59).

SEC Seconds

Number of seconds elapsed in the current minute (0-59).

Detailed Register Description

49_h RTC2 Real Time Clock 2

| | |
|-------------|----------|
| 15 | 0 |
| DAY | HR |
| Reset Value | |
| 0 | 0 |

DAY Days

Number of days elapsed since last reset (0-2047).

HR Hours

Number of hours elapsed in the current day (0-23).

Detailed Register Description

4A_h DOUT0 Data Out (Timeslot 0)

| | | | | |
|-------------|---|---|---|----------|
| 15 | | | | 0 |
| 0 | 0 | 0 | 0 | DATA |
| Reset Value | | | | |
| 0 | 0 | 0 | 0 | 0 |

DATA Output Data

Output data for pins MA₀-MA₁₁ while MA₁₂=1 (only if HWCONFIG1:APP=10).

Note: This register cannot be read.

Detailed Register Description

4B_n DOUT1 Data Out (Timeslot 1)

| | | | | |
|-------------|---|---|---|----------|
| 15 | | | | 0 |
| 0 | 0 | 0 | 0 | DATA |
| Reset Value | | | | |
| 0 | 0 | 0 | 0 | 0 |

DATA Output Data

Output data for pins MA₀-MA₁₁ while MA₁₃=1 (only if HWCONFIG1:APP=10).

Note: This register cannot be read.

Detailed Register Description

4C_h DOUT2 Data Out (Timeslot 2)

| | | | | |
|-------------|---|---|---|----------|
| 15 | | | | 0 |
| 0 | 0 | 0 | 0 | DATA |
| Reset Value | | | | |
| 0 | 0 | 0 | 0 | 0 |

DATA Output Data

Output data for pins MA₀-MA₁₁ while MA₁₄=1 (only if HWCONFIG1:APP=10).

Note: This register cannot be read.

Detailed Register Description

4D_h DOUT3 Data Out (Timeslot 3 or Static Mode)

| | |
|-------------|----------|
| 15 | 0 |
| DATA | |
| Reset Value | |
| 0 | |

DATA Output Data

Output data for pins MA₀-MA₁₁ while MA₁₅=1 (only if HWCONFIG1:APP=10).

Output data for pins MA₀-MA₁₅ (only if HWCONFIG1:APP=01)

Note: This register cannot be read.

Detailed Register Description

4E_h DIN Data In (Timeslot 3 or Static Mode)

15

0



DATA Input Data

Input data for pins MA₀-MA₁₁ at falling edge of MA₁₂ (only if HWCONFIG1:APP=10).

Input data for pins MA₀-MA₁₅ (only if HWCONFIG1:APP=01)

Detailed Register Description

4F_h DDIR Data Direction (Timeslot 3 or Static Mode)

| | | |
|----------------|--|----------|
| 15 | | 0 |
| DIR | | |
| Reset Value | | |
| 0 (all inputs) | | |

DIR Port Direction

Port direction during MA₁₂=1 or in static mode.

0: input

1: output

Note: This register cannot be read.

Electrical Characteristics

4 Electrical Characteristics

4.1 Absolute Maximum Ratings

| Parameter | Symbol | Limit Values | Unit |
|---|-----------|---|------|
| Ambient temperature under bias | T_A | -20 to 85 | °C |
| Storage temperature | T_{STG} | - 65 to 125 | °C |
| Supply Voltage | V_{DD} | -0.5 to 4.2 | V |
| Supply Voltage | V_{DDA} | -0.5 to 4.2 | V |
| Supply Voltage | V_{DDP} | -0.5 to 6 | V |
| Voltage of pin with respect to ground: XTAL ₁ , XTAL ₂ | V_S | 0 to V_{DDA} | V |
| Voltage on any pin with respect to ground | V_S | If $V_{DDP} < 3$ V: - 0.4 to $V_{DD} + 0.5$ If $V_{DDP} > 3$ V: - 0.4 to $V_{DDP} + 0.5$ | V |

ESD integrity (according MIL-Std. 883D, method 3015.7): 2 kV

Exception: The pins \overline{INT} , SDX, DU/DX, DD/DR, SPS₀, SPS₁ and MD₀-MD₇ are not protected against voltage stress >1 kV.

Note: Stresses above those listed here may cause permanent damage to the device. Exposure to absolute maximum ratings conditions for extended periods may affect device reliability.

4.2 DC Characteristics

$V_{DD}/V_{DDA} = 3.3 \text{ V} \pm 0.3 \text{ V}$; $V_{DDP} = 5 \text{ V} \pm 10\%$; $V_{SS}/V_{SSA} = 0 \text{ V}$; $T_A = 0 \text{ to } 70 \text{ °C}$

| Parameter | Symbol | Limit Values | | | Unit | Test Condition |
|--|-----------|-----------------|------|-----------------|------|---------------------------------------|
| | | min. | typ. | max. | | |
| Input leakage current | I_{IL} | - 1.0 | | 1.0 | μA | $0 \text{ V} \leq V_{IN} \leq V_{DD}$ |
| H-input level (except MA ₀ -MA ₁₅ , XTAL ₁ , OSC ₁) | V_{IH1} | 2.0 | | $V_{DDP} + 0.3$ | V | |
| H-input level (OSC ₁) | V_{IH2} | 0.8 V_{DD} | | $V_{DDA} + 0.3$ | V | |
| H-input level (MA ₀ -MA ₁₅ , MCTL ¹) | V_{IH3} | 2.0 | | V_{DD} | V | |
| L-input level (except pins XTAL ₁ , OSC ₁) | V_{IL1} | - 0.3 | | 0.8 | V | |

Electrical Characteristics

 $V_{DD}/V_{DDA} = 3.3 \text{ V} \pm 0.3 \text{ V}; V_{DDP} = 5 \text{ V} \pm 10\%; V_{SS}/V_{SSA} = 0 \text{ V}; T_A = 0 \text{ to } 70 \text{ }^\circ\text{C}$

| Parameter | Symbol | Limit Values | | | Unit | Test Condition |
|---|-------------------|------------------------|------|-------------------------|------|-------------------------|
| | | min. | typ. | max. | | |
| L-input level (OSC ₁) | V _{IL2} | - 0.3 | | 0.2 V _{DDA} | V | |
| H-output level (except DU/DX, DD/DR, MA ₀ -MA ₁₅ , SPS ₀ , SPS ₁ , MD ₀ -MD ₇) | V _{OH1} | V _{DD} - 0.45 | | | V | I _O = 2 mA |
| H-output level (SPS ₀ , SPS ₁ , MD ₀ -MD ₇ , SDX, INT) | V _{OH2} | V _{DD} - 0.6 | | | V | I _O = 2 mA |
| H-output level (MA ₀ -MA ₁₅) | V _{OH3} | V _{DD} - 0.45 | | | V | I _O = 5 mA |
| H-output level (DU/DX, DD/DR) | V _{OH4} | V _{DD} - 0.6 | | | V | I _O = 7 mA |
| L-output level (except DU/DX, DD/DR, MA ₀ -MA ₁₅) | V _{OL1} | | | 0.45 | V | I _O = - 2 mA |
| L-output level (MA ₀ -MA ₁₅) (address mode or APP output) | V _{OL2} | | | 0.45 | V | I _O = - 5 mA |
| L-output current (MA ₀ -MA ₁₅) (after reset) | I _{LO} | 50 | 150 | 240 | μA | RST=1 |
| H-output current (MCTL ¹⁾) | I _{HO} | 25 | 65 | 120 | μA | RST=1 |
| L-output level (pins DU/DX, DD/DR) | V _{OL3} | | | 0.45 | V | I _O = - 7 mA |
| Internal pullup current (FRDY) | I _{LI} | 350 | 750 | 1300 | μA | |
| Input capacitance | C _I | | | 10 | pF | |
| Output capacitance | C _O | | | 15 | pF | |
| V _{DD} supply current (power down, no refresh, no RTC) | I _{DDS1} | | 10 | 50 | μA | |
| V _{DD} supply current (power down, refresh, RTC) | I _{DDS2} | | 20 | 70 | μA | |
| V _{DD} supply current operating | I _{DDO} | | 55 | 70 | mA | V _{DD} = 3.3 V |
| V _{DDP} supply current | I _{DDP} | | 1 | 10 | μA | |

¹⁾ MCTL signals are ($\overline{W}/\overline{FWE}$, $\overline{VPRD}/\overline{FCLE}$, $\overline{RAS}/\overline{FOE}$, $\overline{CAS_0}/\overline{ALE}$, $\overline{CAS_1}/\overline{FCS}$)

Electrical Characteristics

4.3 AC Characteristics

Digital inputs are driven to 2.4 V for a logical “1” and to 0.45 V for a logical “0”. Timing measurements are made at 2.0 V for a logical “1” and 0.8 V for a logical “0”. The AC-testing input/output waveforms are shown below.

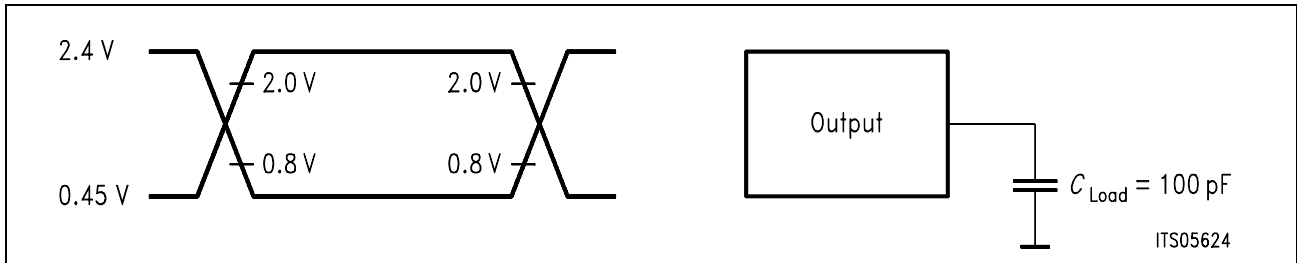

Figure 55 Input/Output Waveforms for AC-Tests

Electrical Characteristics

DTMF Detector

| Parameter | Symbol | Limit Values | | | Unit | Test Condition |
|----------------------------|--------|--------------|------|------|------|------------------|
| | | min. | typ. | max. | | |
| Frequency deviation accept | | -1.5 | | 1.5 | % | |
| Frequency deviation reject | | 3.5 | | -3.5 | % | |
| Acceptance level | | -45 | | 0 | dB | rel. to max. PCM |
| Rejection level | | | | -50 | dB | rel. to max. PCM |
| Twist deviation accept | | +/-2 | | +/-8 | dB | programmable |
| Noise Tolerance | | | | 12 | dB | |
| Signal duration accept | | 40 | | | ms | |
| Signal duration reject | | | | 23 | ms | |
| Gap duration accept | | 18 | | | ms | |

CPT Detector

| Parameter | Symbol | Limit Values | | | Unit | Test Condition |
|----------------------------|--------|--------------|------|------|------|------------------|
| | | min. | typ. | max. | | |
| Frequency acceptance range | | 300 | | 640 | Hz | |
| Frequency rejection range | | 800 | | 200 | Hz | |
| Acceptance level | | -45 | | 0 | dB | rel. to max. PCM |
| Rejection level | | | | -50 | dB | rel. to max. PCM |
| Signal duration accept | | 50 | | | ms | programmable |
| Signal duration reject | | | | 10 | ms | |

Caller ID Decoder

| Parameter | Symbol | Limit Values | | | Unit | Test Condition |
|----------------------------|--------|--------------|------|------|------|------------------|
| | | min. | typ. | max. | | |
| Frequency deviation accept | | -2 | | 2 | % | |
| Acceptance level | | -45 | | 0 | dB | rel. to max. PCM |
| Transmission rate | | 1188 | 1200 | 1212 | baud | |
| Noise Tolerance | | | | -12 | dB | |

Electrical Characteristics

Alert Tone Detector

| Parameter | Symbol | Limit Values | | | Unit | Test Condition |
|----------------------------|--------|--------------|------|------|------|--------------------------|
| | | min. | typ. | max. | | |
| Frequency deviation accept | | -0.5 | | 0.5 | % | ATDCTL1:DEV=0 |
| Frequency deviation accept | | -1.1 | | 1.1 | % | ATDCTL1:DEV=1 |
| Frequency deviation reject | | 3.5 | | -3.5 | % | |
| Acceptance level | | -40 | | 0 | dB | rel. to max. PCM |
| Rejection level | | | | -5 | dB | rel. to acceptance level |
| Twist deviation accept | | | | +/-7 | dB | |
| Noise Tolerance | | | | 20 | dB | |
| Signal duration accept | | 75 | | | ms | |
| Gap duration accept | | 40 | | | ms | |

CNG Detector

| Parameter | Symbol | Limit Values | | | Unit | Test Condition |
|----------------------------|--------|--------------|------|------|------|--------------------|
| | | min. | typ. | max. | | |
| Frequency deviation accept | | -40 | | 40 | Hz | |
| Frequency deviation reject | | -50 | | 50 | Hz | |
| Acceptance level | | -45 | | 0 | dB | SNR >10 dB |
| Acceptance level | | -50 | | 0 | dB | SNR >15 dB |
| Rejection level | | -3 dB | | | dB | rel. to CNGLEV:MIN |
| Signal duration reject | | | | -1 | % | rel. to CNGBT:TIME |

Electrical Characteristics

Status Register Update Time

The individual bits of the STATUS register may change due to an event (like a recognized DTMF tone) or a command. The timing can be divided into four classes

Table 74 Status Register Update Timing

| Class | Timing | | Comment |
|-------|-------------|---------------------------|---|
| | Min. | Max. | |
| I | 0 | 0 | Immediately after command has been issued |
| A | 0 | 125 μ s ¹⁾ | Command has been accepted |
| D | 125 μ S | 250 μ s | Deactivation time after command has been issued |
| E | - | - | Associated event has happened |

¹⁾ one FSC period

With these definitions the timing of the individual bits in the STATUS register can be given as shown in table:

| Bit | RDY | ABT | CIA | CD | CPT | CNG | SD | ERR | BSY | DTV | ATV |
|----------------|-----|-----|-----|-----|-----|-----|-----|-----|-----------------|-----|-----|
| 0->1 | A | E | E | E | E | E | E | E | A ¹⁾ | E | E |
| 1->0 | I | A | A,D | E,D | E,D | D | E,D | A | E | E,D | E,D |

¹⁾ up to 30 ms if command is either SDCTL:EN=1 or SCCTL:EN=1

Electrical Characteristics

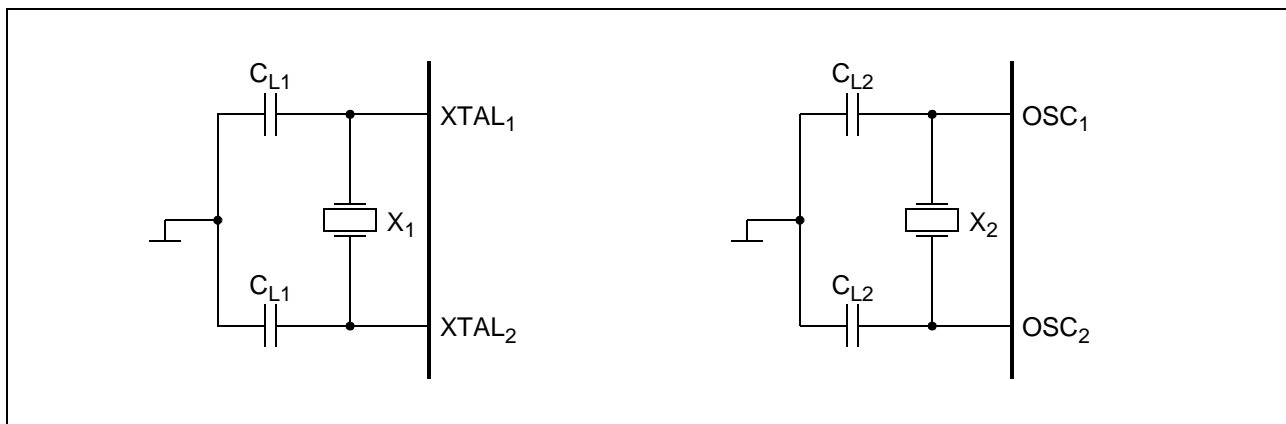

Figure 56 Oscillator Circuits

| Recommended Values Oscillator Circuits | Value | | | Unit |
|---|-------|-----|-----|------|
| | Min | Typ | Max | |
| Load CL ₁ | | | 40 | pF |
| Static capacitance X ₁ | | | 5 | pF |
| Motional capacitance X ₁ | | | 17 | fF |
| Resonance resistor X ₁ | | | 60 | Ω |
| Load CL ₂ | | | 30 | pF |
| Static Capacitance X ₂ | | 1.7 | | pF |
| Motional capacitance X ₂ | | 3.5 | | fF |
| Resonance resistor X ₂ | | 18 | 40 | kΩ |
| Frequency deviation | | | 100 | ppm |

Electrical Characteristics

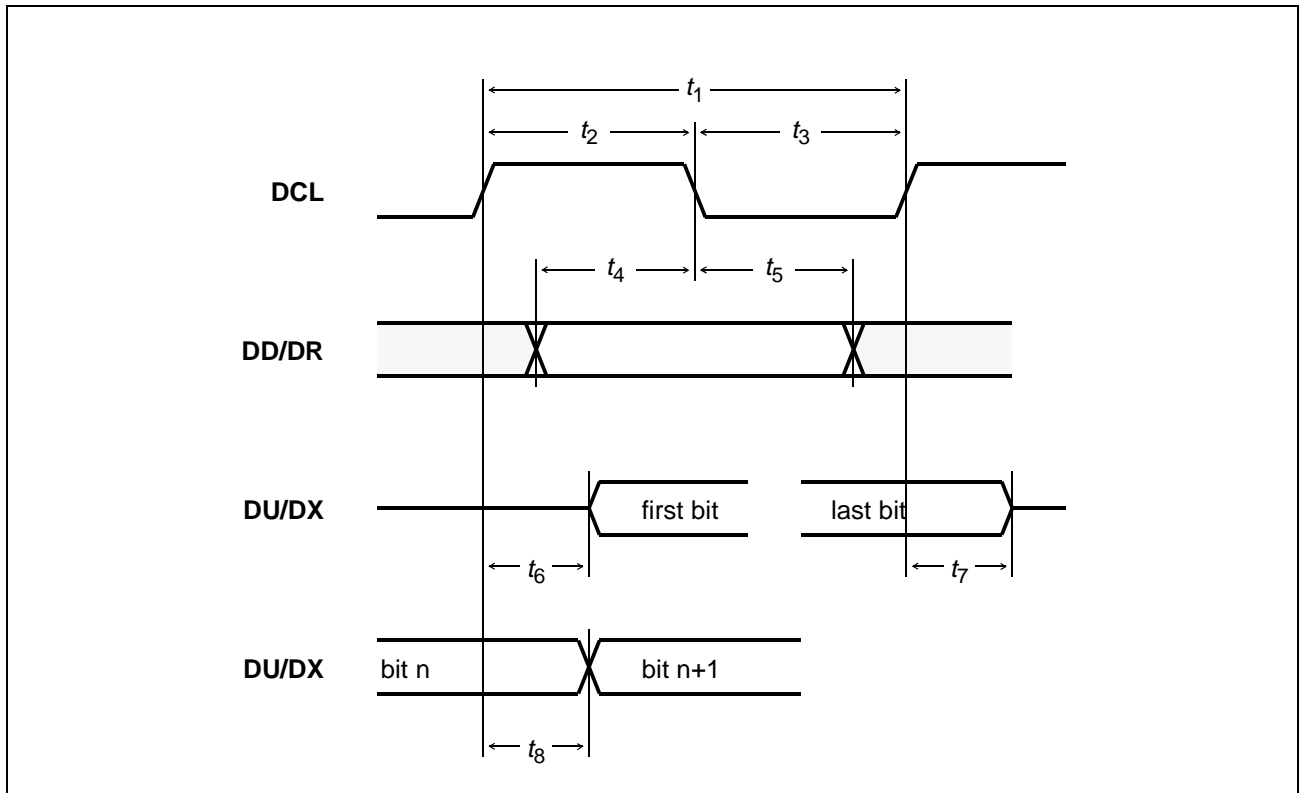

Figure 57 SSDI/IOM[®]-2 Interface - Bit Synchronization Timing

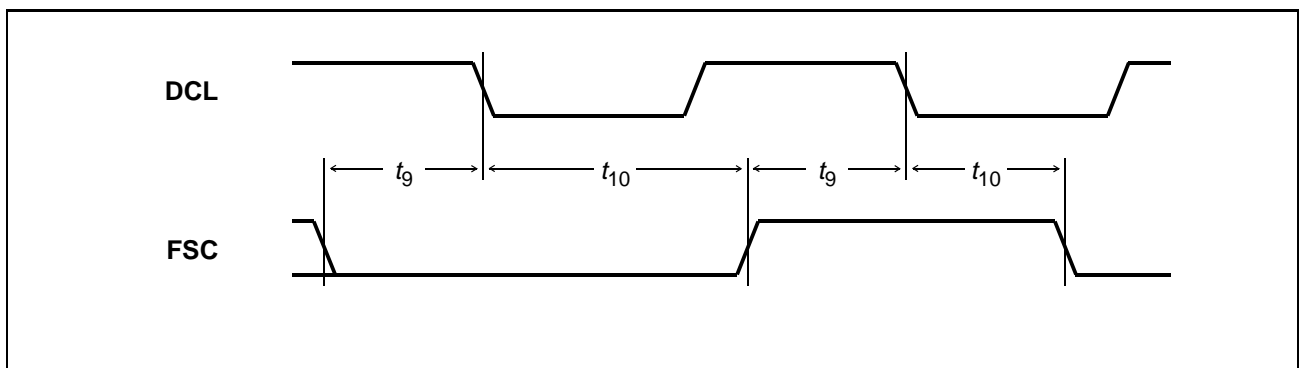

Figure 58 SSDI/IOM[®]-2 Interface - Frame Synchronization Timing

| Parameter SSDI/IOM [®] -2 Interface | Symbol | Limit values | | Unit |
|---|--------|--------------|-----|------|
| | | Min | Max | |
| DCL period | t_1 | 90 | | ns |
| DCL high | t_2 | 35 | | ns |
| DCL low | t_3 | 35 | | ns |
| Input data setup | t_4 | 20 | | ns |

Electrical Characteristics

| Parameter SSDI/IOM [®] -2 Interface | Symbol | Limit values | | Unit |
|--|----------|--------------|-----|------|
| | | Min | Max | |
| Input data hold | t_5 | 20 | | ns |
| Output data from high impedance to active (FSC high or other than first timeslot) | t_6 | | 30 | ns |
| Output data from active to high impedance | t_7 | | 30 | ns |
| Output data delay from clock | t_8 | | 30 | ns |
| FSC setup | t_9 | 40 | | ns |
| FSC hold | t_{10} | 40 | | ns |
| FSC jitter (deviation per frame) | | -200 | 200 | ns |

Electrical Characteristics

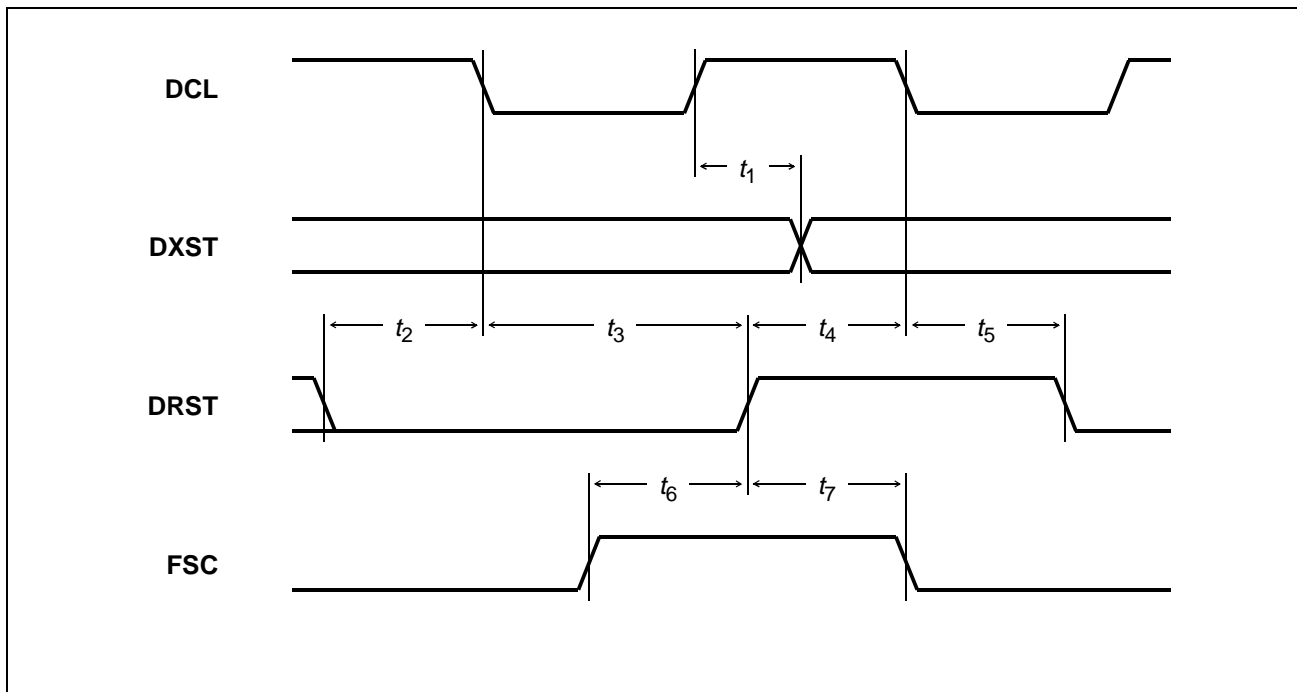

Figure 59 SSDI Interface - Strobe Timing

| Parameter SSDI Interface | Symbol | Limit values | | Unit |
|-----------------------------|--------|--------------|-----|------------|
| | | Min | Max | |
| DXST delay | t_1 | | 20 | ns |
| DRST inactive setup | t_2 | 20 | | ns |
| DRST inactive hold | t_3 | 20 | | ns |
| DRST active setup | t_4 | 20 | | ns |
| DRST active hold | t_5 | 20 | | ns |
| FSC setup | t_6 | 8 | | DCL cycles |
| FSC hold | t_7 | 40 | | ns |

Electrical Characteristics

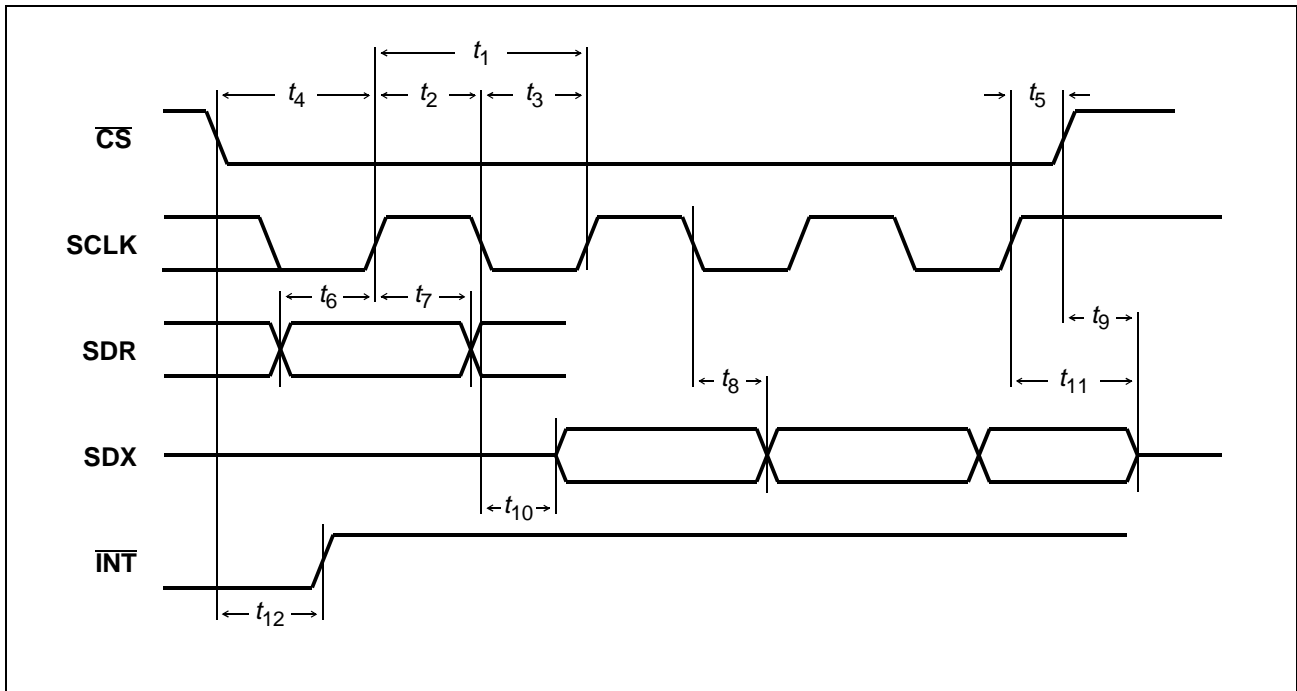

Figure 60 Serial Control Interface

| Parameter SCI Interface | Symbol | Limit values | | Unit |
|---|----------|--------------|-----|------|
| | | Min | Max | |
| SCLK cycle time | t_1 | 500 | | ns |
| SCLK high time | t_2 | 100 | | ns |
| SCLK low time | t_3 | 100 | | ns |
| \overline{CS} setup time | t_4 | 40 | | ns |
| \overline{CS} hold time | t_5 | 10 | | ns |
| SDR setup time | t_6 | 40 | | ns |
| SDR hold time | t_7 | 40 | | ns |
| SDX data out delay | t_8 | | 80 | ns |
| \overline{CS} high to SDX tristate | t_9 | | 40 | ns |
| SCLK to SDX active | t_{10} | | 80 | ns |
| SCLK to SDX tristate | t_{11} | | 40 | ns |
| \overline{CS} to \overline{INT} delay | t_{12} | | 80 | ns |

Electrical Characteristics

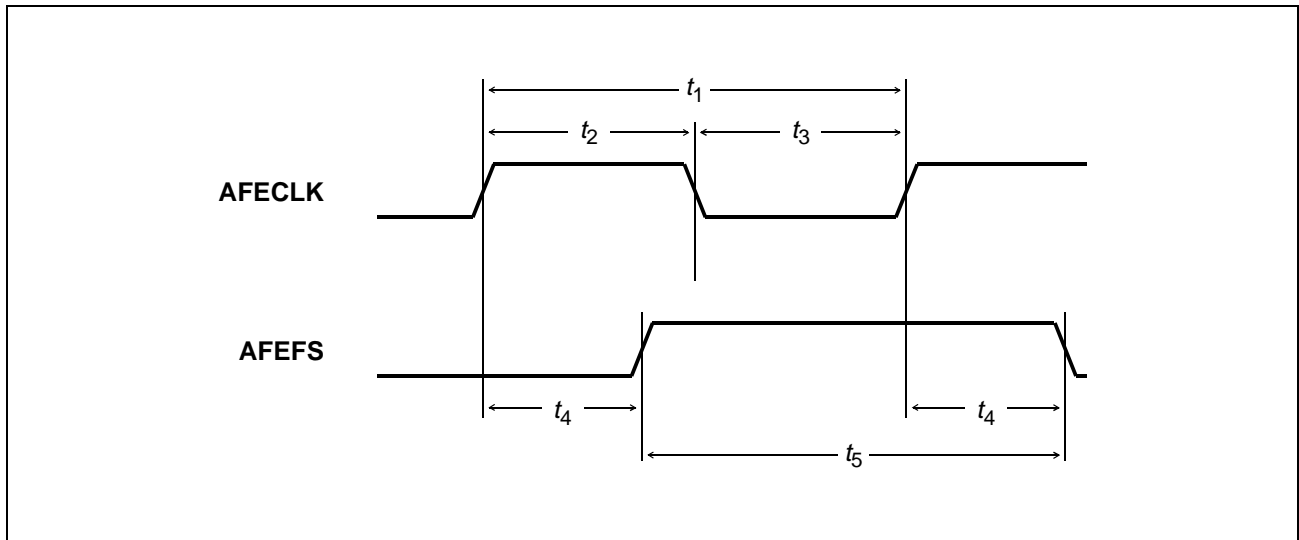

Figure 61 Clock Master Timing

| Parameter AFE Interface | Symbol | Limit values | | Unit |
|------------------------------------|--------|-----------------------------------|------------------------------|------|
| | | Min | Max | |
| AFECLK period (HWCONFIG3:CM0=0) | t_1 | $13.5 \cdot p^{1)}/f_{XTAL} - 10$ | $13.5 \cdot p/f_{XTAL} + 10$ | ns |
| AFECLK period (HWCONFIG3:CM0=1) | t_1 | $4.5 \cdot p/f_{XTAL} - 10$ | $4.5 \cdot p/f_{XTAL} + 10$ | ns |
| AFECLK high | t_2 | $4 \cdot 1/f_{XTAL}$ | | |
| AFECLK low | t_3 | $4 \cdot 1/f_{XTAL}$ | | |
| AFEFS output delay | t_4 | | 30 | ns |
| AFEFS high | t_5 | $4 \cdot t_1$ | | |

¹⁾ The factor p is determined by HWCONFIG1:XTAL (see register description)

Electrical Characteristics

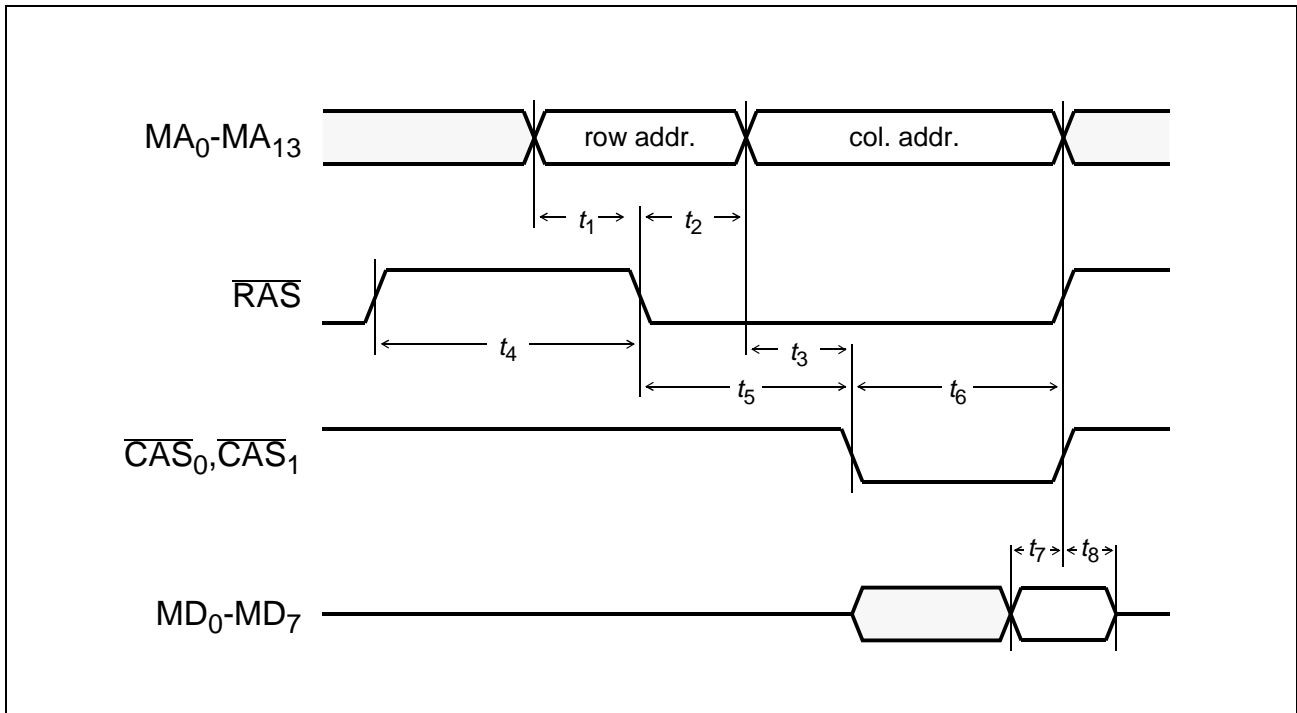

Figure 62 Memory Interface - DRAM Read Access

| Parameter Memory Interface - DRAM Read Access | Symbol | Limit values | | Unit |
|--|--------|--------------|------|------|
| | | Min | Max | |
| row address setup time | t_1 | 50 | | ns |
| row address hold time | t_2 | 50 | | ns |
| column address setup time | t_3 | 50 | | ns |
| $\overline{\text{RAS}}$ precharge time | t_4 | 110 | | ns |
| $\overline{\text{RAS}}$ to $\overline{\text{CAS}}$ delay | t_5 | 110 | 2000 | ns |
| $\overline{\text{CAS}}$ pulse width | t_6 | 110 | 2000 | ns |
| Data input setup time | t_7 | 40 | | ns |
| Data input hold time | t_8 | 0 | | ns |

Electrical Characteristics

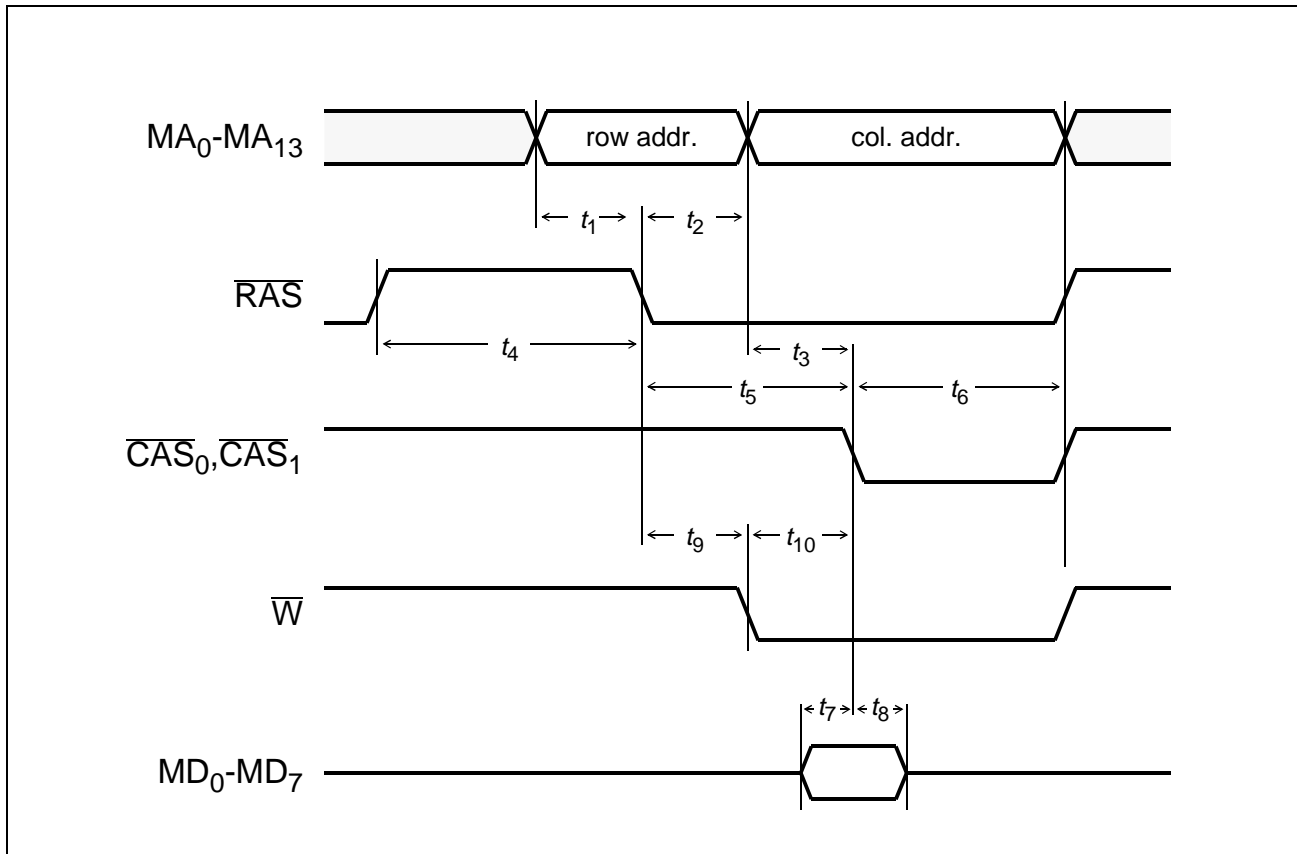

Figure 63 Memory Interface - DRAM Write Access

| Parameter Memory Interface - DRAM Write Access | Symbol | Limit values | | Unit |
|---|----------|--------------|------|------|
| | | Min | Max | |
| row address setup time | t_1 | 50 | | ns |
| row address hold time | t_2 | 50 | | ns |
| column address setup time | t_3 | 50 | | ns |
| RAS precharge time | t_4 | 110 | | ns |
| RAS to CAS delay | t_5 | 110 | 2000 | ns |
| CAS pulse width | t_6 | 110 | 2000 | ns |
| Data output setup time | t_7 | 100 | | ns |
| Data output hold time | t_8 | 50 | | ns |
| RAS to W delay | t_9 | 50 | | ns |
| W to CAS setup | t_{10} | 50 | | ns |

Electrical Characteristics

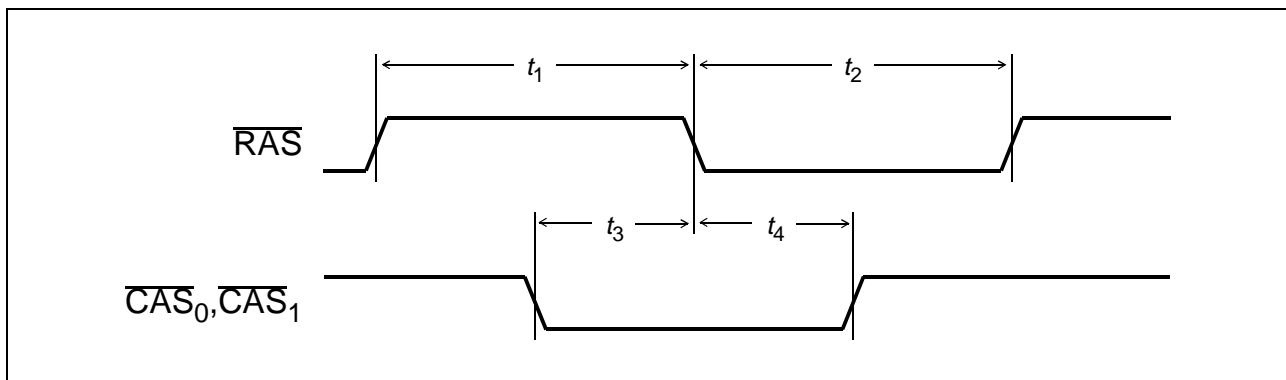

Figure 64 Memory Interface - DRAM Refresh Cycle

| Parameter Memory Interface - DRAM Refresh Cycle | Symbol | Limit values | | Unit |
|--|--------|--------------|------|------|
| | | Min | Max | |
| $\overline{\text{RAS}}$ precharge time | t_1 | 100 | | ns |
| $\overline{\text{RAS}}$ low time | t_2 | 200 | 5000 | ns |
| $\overline{\text{CAS}}$ setup | t_3 | 100 | | ns |
| $\overline{\text{CAS}}$ hold | t_4 | 100 | | ns |

Note: The frequency of the DRAM refresh cycle depends on the selected mode. In active mode or normal refresh mode (during power down) the minimal frequency is 64 kHz. In battery backup mode, the refresh frequency is 8 kHz.

Electrical Characteristics

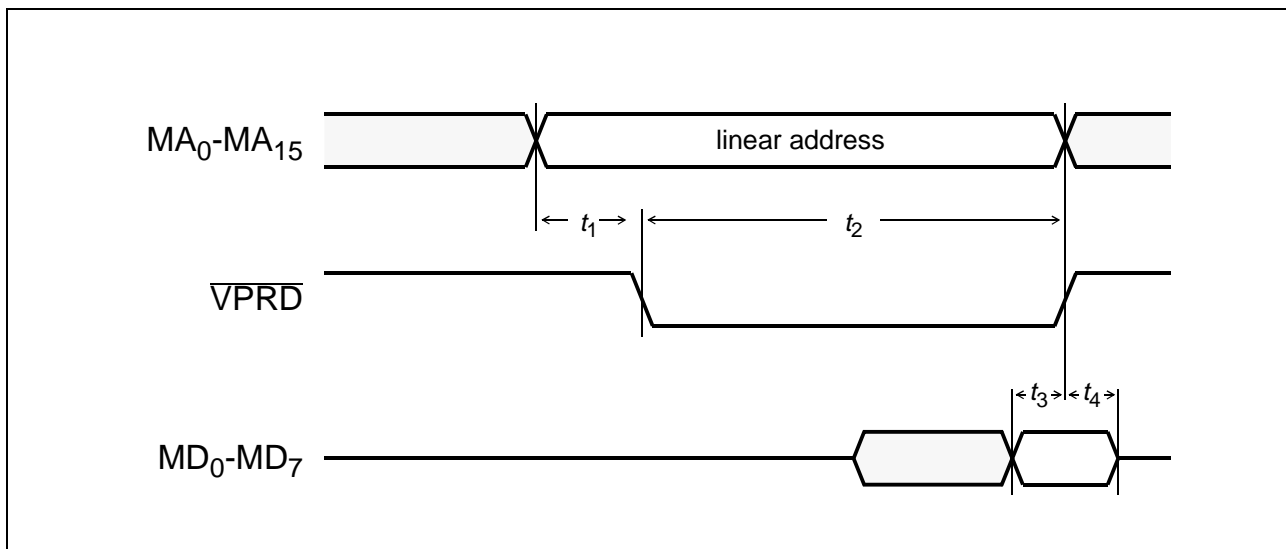

Figure 65 Memory Interface - EPROM Read

| Parameter Memory Interface - EPROM Read | Symbol | Limit values | | Unit |
|--|--------|--------------|-----|------|
| | | Min | Max | |
| Address setup before \overline{VPRD} | t_1 | 110 | | ns |
| \overline{VPRD} low time | t_2 | 500 | | ns |
| Data setup time | t_3 | 40 | | ns |
| Data hold time | t_4 | 0 | | ns |

Electrical Characteristics

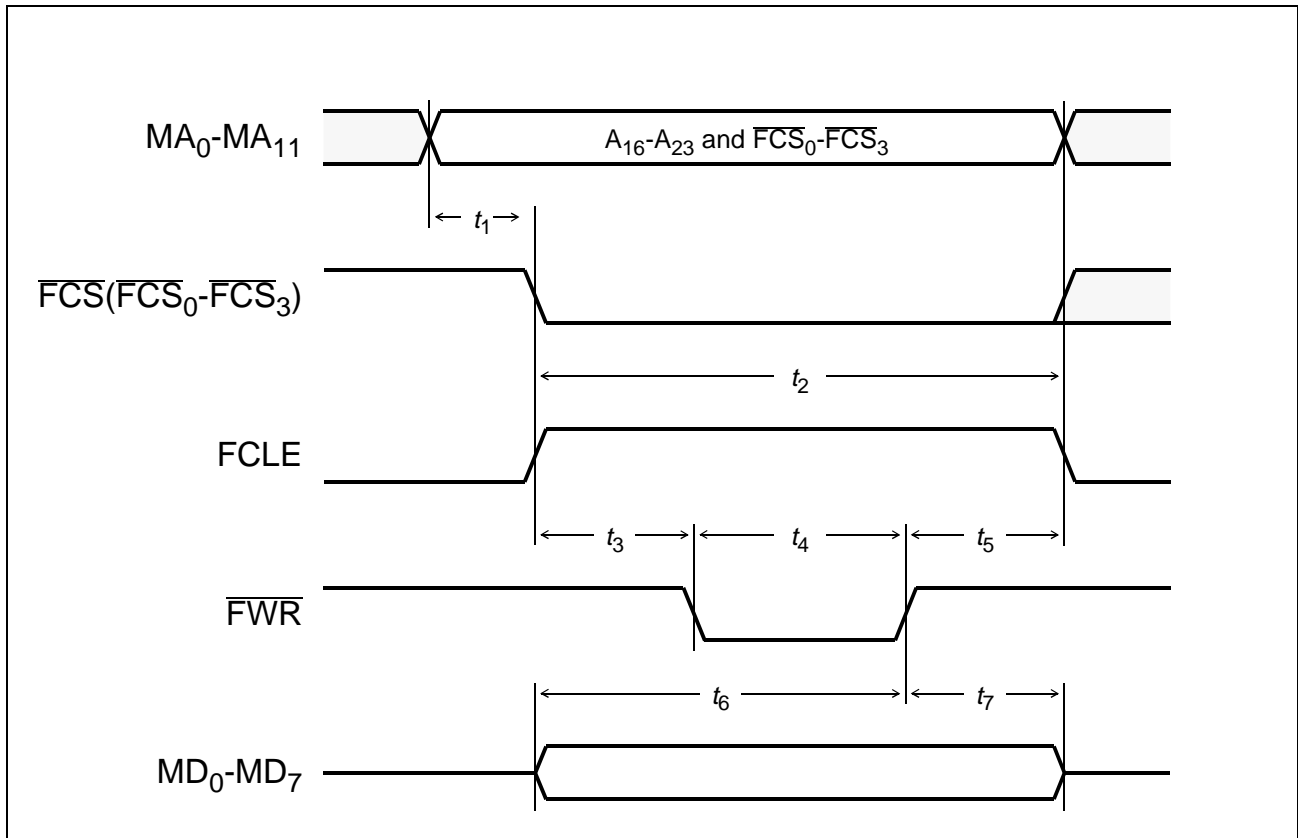

Figure 66 Memory Interface - Samsung Command Write

| Parameter Memory Interface - Samsung Command Write | Symbol | Limit values | | Unit |
|---|--------|--------------|-----|------|
| | | Min | Max | |
| Address setup before FCS, FCLE | t_1 | 100 | | ns |
| FCS low time, FCLE high time | t_2 | 400 | | ns |
| FWR hold after FCLE rising | t_3 | 100 | | ns |
| FWR low time | t_4 | 200 | | ns |
| FWR setup before FCLE falling | t_5 | 100 | | ns |
| Data setup time | t_6 | 200 | | ns |
| Data hold time | t_7 | 50 | | ns |

Note: FCS stays low if other cycles follow for the same access.

Electrical Characteristics

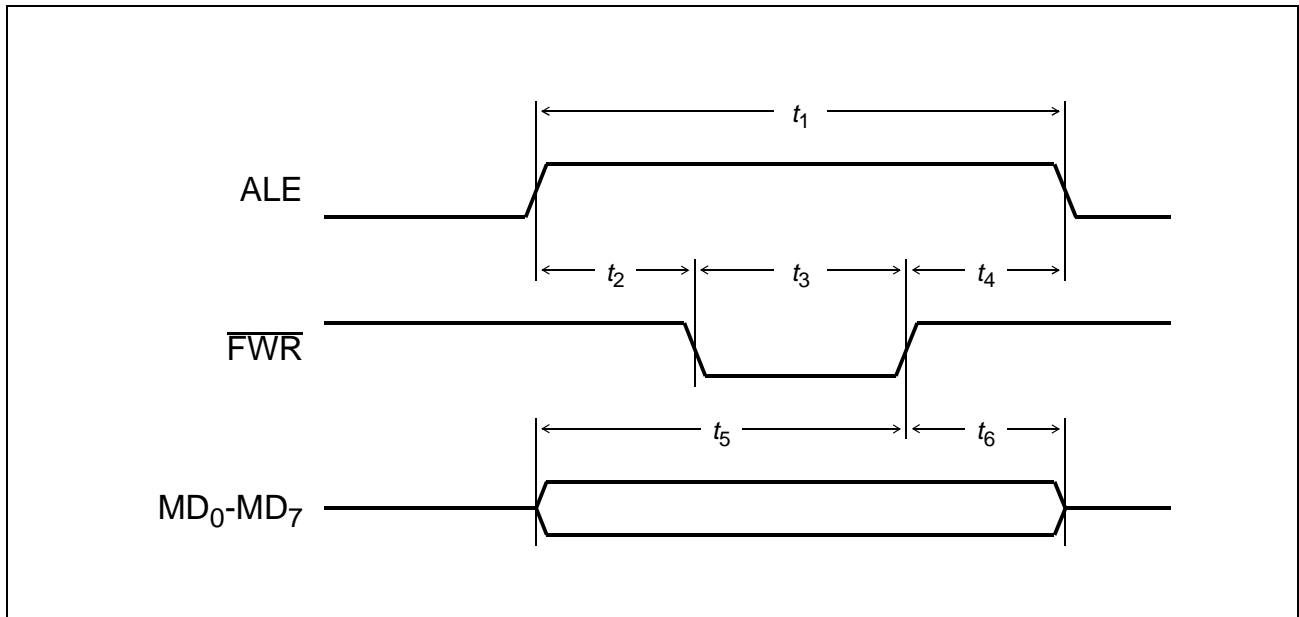

Figure 67 Memory Interface - Samsung Address Write

| Parameter Memory Interface - Samsung Address Write | Symbol | Limit values | | Unit |
|---|--------|--------------|-----|------|
| | | Min | Max | |
| ALE high time | t_1 | 400 | | ns |
| FWR hold after ALE rising | t_2 | 100 | | ns |
| FWR low time | t_3 | 200 | | ns |
| FWR setup before ALE falling | t_4 | 100 | | ns |
| Data setup time | t_5 | 200 | | ns |
| Data hold time | t_6 | 50 | | ns |

Electrical Characteristics

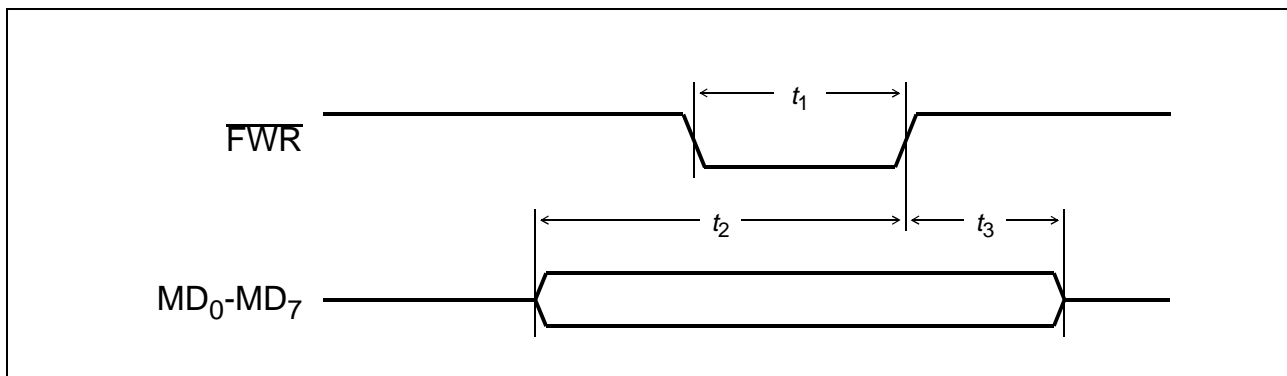

Figure 68 Memory Interface - Samsung Data Write

| Parameter Memory Interface - Samsung Data Write | Symbol | Limit values | | Unit |
|--|--------|--------------|-----|------|
| | | Min | Max | |
| \overline{FWR} low time | t_1 | 200 | | ns |
| Data setup time | t_2 | 200 | | ns |
| Data hold time | t_3 | 50 | | ns |

Electrical Characteristics

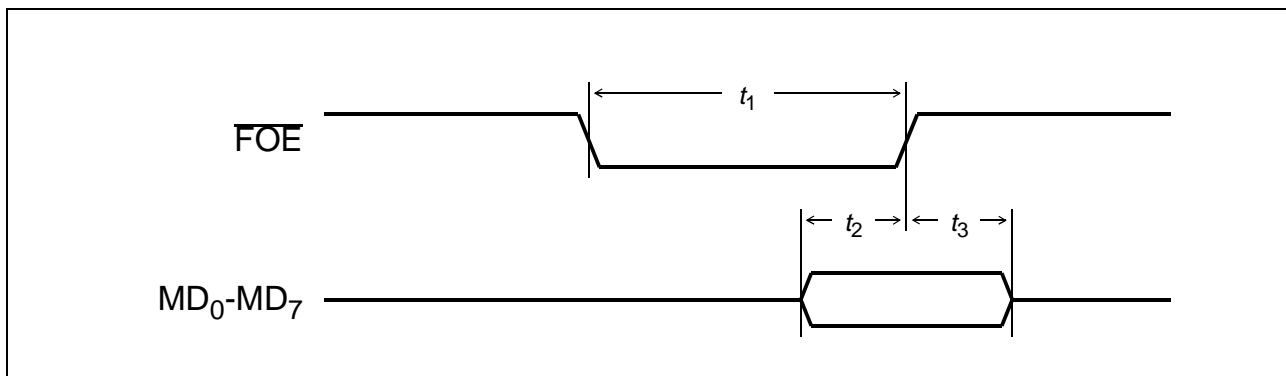

Figure 69 Memory Interface - Samsung Data Read

| Parameter Memory Interface - Samsung Data Read | Symbol | Limit values | | Unit |
|---|--------|--------------|-----|------|
| | | Min | Max | |
| $\overline{\text{FOE}}$ low time | t_1 | 200 | | ns |
| Data setup time | t_2 | 40 | | ns |
| Data hold time | t_3 | 0 | | ns |

Electrical Characteristics

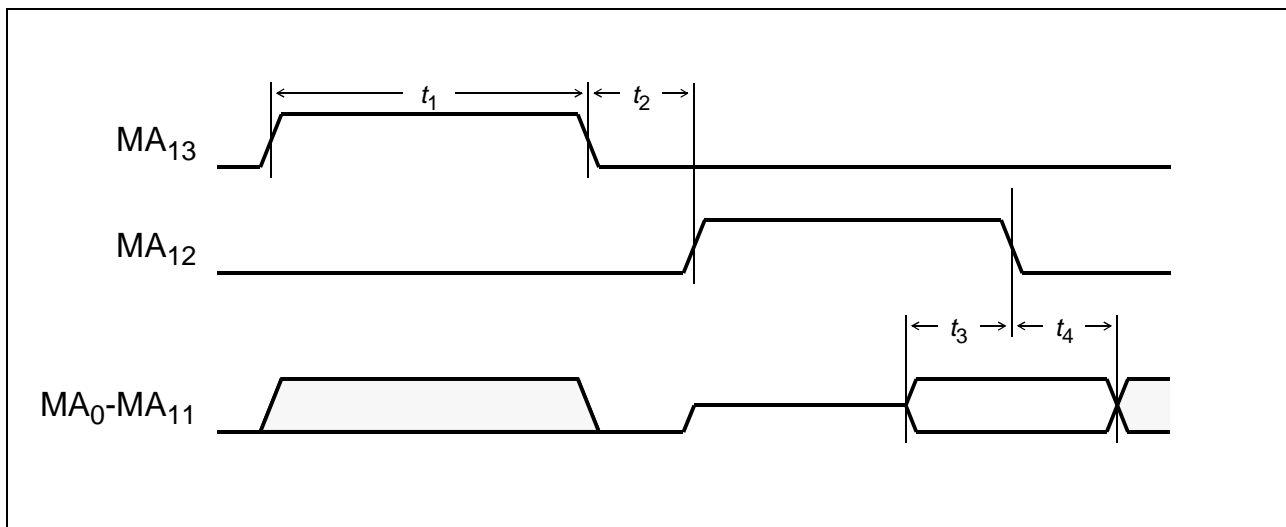

Figure 70 Auxiliary Parallel Port - Multiplex Mode

| Parameter Auxiliary Port Interface - Multiplex Mode | Symbol | Limit values | | | Unit |
|--|----------------|--------------|-----|-----|------|
| | | Min | Typ | Max | |
| Active time (MA ₀ -MA ₁₅) | t ₁ | | 2 | | ms |
| Gap time (MA ₀ -MA ₁₅) | t ₂ | | 125 | | μs |
| Data setup time | t ₃ | 50 | | | ns |
| Data hold time | t ₄ | 0 | | | ns |

Electrical Characteristics

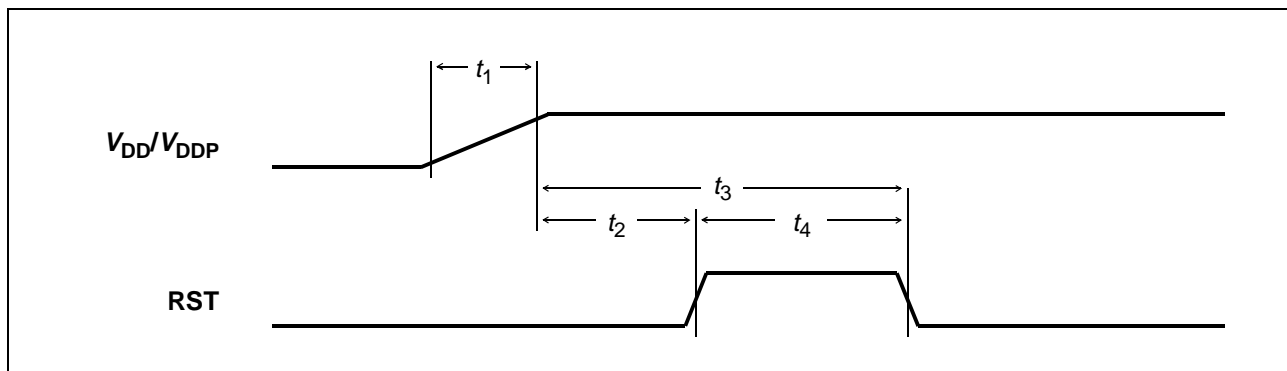
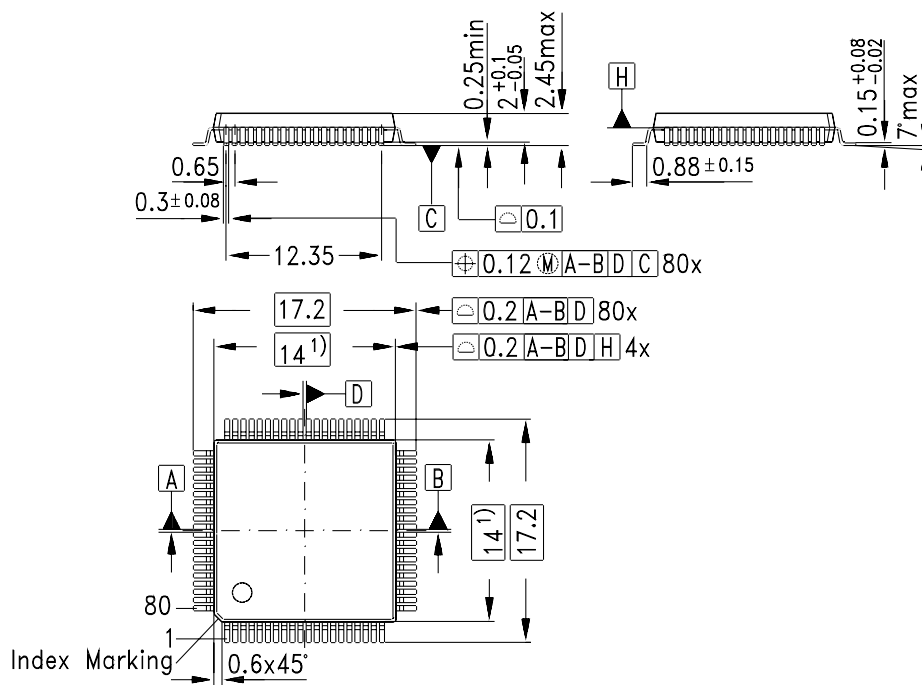

Figure 71 Reset Timing

| Parameter Reset Timing | Symbol | Limit values | | Unit |
|---|--------|--------------|-----|------|
| | | Min | Max | |
| $V_{DD}/V_{DDP}/V_{DDA}$ rise time 5%-95% | t_1 | | 20 | ms |
| Supply voltages stable to RST high | t_2 | 0 | | ns |
| Supply voltages stable to RST low | t_3 | 0.1 | | ms |
| RST high time | t_4 | 1000 | | ns |

5 Package Outlines

Plastic Package, P-MQFP-80 (SMD)
(Plastic Metric Quad Flat Package)



1) Does not include plastic or metal protrusions of 0.25 max per side

Sorts of Packing

Package outlines for tubes, trays etc. are contained in our Data Book "Package Information".

SMD = Surface Mounted Device

Dimensions in mm

A

Abort

- Clearing Event 63, 96
- Functional Description 62
- Status Bit 87

Alert Tone Detector

- Electrical Characteristics 164
- Functional Description 28
- Registers 116–117
- Status Bit 88

ARAM

- see Memory Interface

Automatic Gain Control

- Functional Description 40
- Registers 139–145

Auxiliary Parallel Port

- Electrical Characteristics 180
- Mode Bits 90
- Multiplex Mode 85
- Registers 154–159
- Static Mode 85

C

Caller ID Decoder

- Electrical Characteristics 163
- Functional Description 31
- Registers 118–119
- Status Bits 87

CNG Detector

- Electrical Characteristics 164
- Functional Description 27
- Registers 112–115
- Status Bit 88

CPT Detector

- Electrical Characteristics 163

- Functional Description 29
- Registers 120–124
- Status Bit 88

D

Digital Interface

- Functional Description 37
- Mode Bits 90

DRAM

- see Memory Interface

DTMF Detector

- Electrical Characteristics 163
- Functional Description 26
- Registers 129–131
- Status Bit 88

DTMF Generator

- Functional Description 33
- Registers 107–111

E

EPROM

- see Memory Interface

Equalizer

- Functional Description 42
- Registers 132–134

Execution Times

- File Commands 58

F

File

- Commands

 - Access File Descriptor 53
 - Compress 52
 - Create Next New 50
 - Delete 52
 - Execution Times 58

New File 50
 Open 50
 Read Binary Data 54
 Registers 146–150
 Restrictions 59
 Seek 51
 Status Bits 88
 Tailcut 52
 Write Binary Data 55
 Type
 Audio 45
 Binary 45
 Phrase 46
 User Data Word 47
 Flash Memory
 see Memory Interface

H

Hardware Configuration
 Functional Description 63
 Registers 89

I

Interrupt
 Functional Description 61
 Pin Configuration 89
 Register 98
 IOM®-2 Interface
 Electrical Characteristics 167–168
 Functional Description 66
 see also: Digital Interface

L

Line Echo Canceller
 Functional Description 24
 Registers 125–128

M

Memory Interface
 ARAM/DRAM
 Connection Diagram 77
 Electrical Characteristics ... 172–174
 Refresh 79, 91
 Timing 78
 EPROM
 Connection Diagram 80
 Electrical Characteristics 175
 Timing 80
 Flash
 Connection Diagram 81
 Electrical Characteristics ... 176–179
 In-Circuit Programming 76, 91
 Multiple Devices 82
 Timing 83
 Register 97
 Supported Devices 76
 Memory Management
 Activation 49
 Directories 44
 ExecutionTimes 58
 Files 45
 Garbage Collection 53
 Initialization 48
 Memory Status 53
 Overview 44
 Status 46

O

Oscillator
 Electrical Characteristics 166
 Mode Bits 90

P

Power Down

Functional Description 60
 Status Bit 89

R

Real Time Clock
 Configuration Bits 89
 Functional Description 60
 Oscillator 166
 Registers 152–153
 Recompression 52
 Reset
 Electrical Characteristics 181
 Functional Description 60
 Register Values 93
 Restrictions
 File Commands 59
 Modules 64
 Revision
 Functional Description 63
 Register 96

S

Serial Control Interface
 Command Opcodes 75
 Electrical Characteristics 170
 Functional Description 72
 Signals
 Encoding 94
 Reference Table 94
 Speech Coder
 Functional Description 34
 Registers 135–137
 Speech Decoder
 Functional Description 36
 Register 138

SPS Outputs
 Functional Description 60
 Register 151

SSDI Interface
 Electrical Characteristics 167–169
 Functional Description 70
 see also: Digital Interface

Status Register
 Definition 87
 Update Timing 165

U

Universal Attenuator
 Functional Description 39
 Register 106